

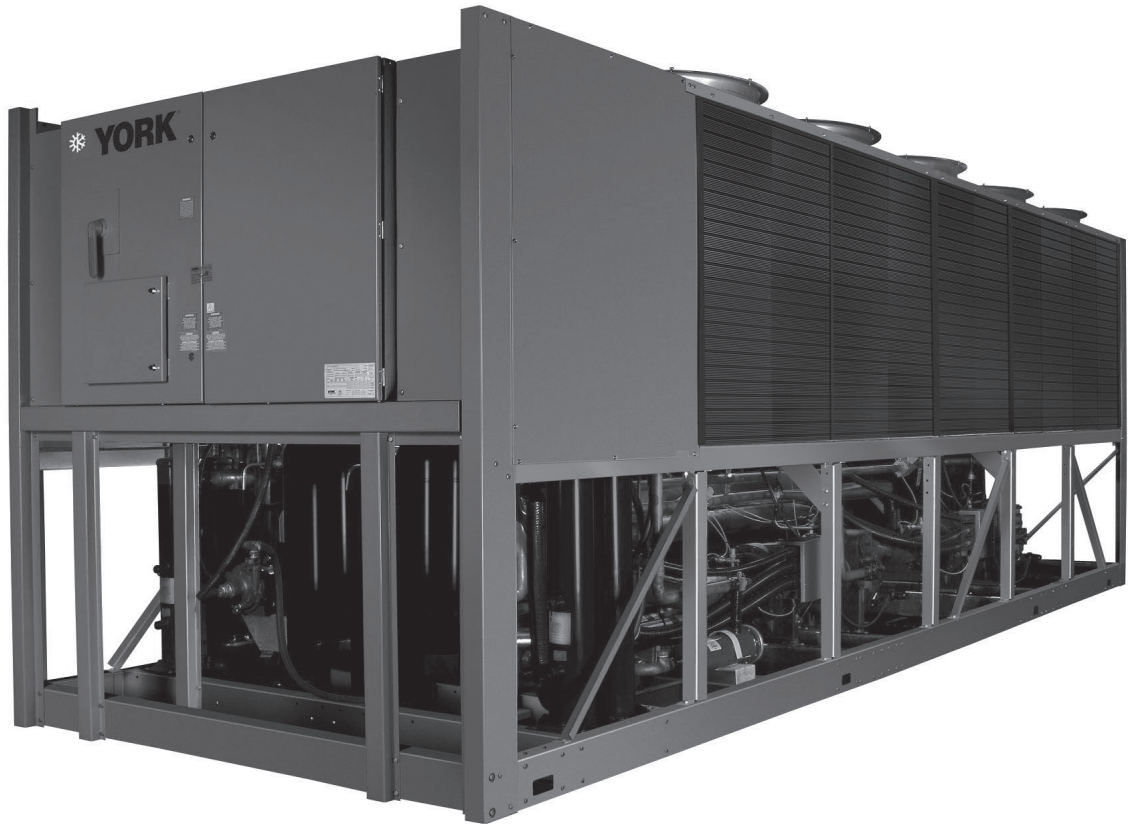

BY JOHNSON CONTROLS



***Model YCAV Air-Cooled Screw Compressor Liquid Chillers  
Style A***



**150 -385 TONS & 385 - 515 TONS**  
**527 - 1354 kW & 1354 - 1804 kW**  
**60 Hz 50 & 60 Hz**  
**ASHRAE 90.1 Compliant**



# Table of Contents

---

FORM 201.21-EG1 (209) .....	1
Introduction.....	3
Specifications .....	4
Accessories and Options .....	7
Nomenclature.....	9
Temperatures and Flows .....	10
Water Pressure Drop.....	12
Efficiency.....	16
Standard Efficiency Ratings - English - 60Hz .....	18
High Efficiency Ratings - English - 60Hz.....	30
Standard Efficiency Ratings - SI - 60Hz.....	40
High Efficiency Ratings - SI - 60Hz .....	46
Standard Efficiency Ratings - SI - 50Hz.....	52
Standard Efficiency Ratings - SI - 50Hz - continued .....	54
Standard Efficiency Ratings - SI - 50Hz - continued .....	56
High Efficiency Ratings - SI - 50Hz .....	58
High Efficiency Ratings - SI - 50Hz - continued.....	60
High Efficiency Ratings - SI - 50Hz - continued.....	62
Physical Data (English - Standard Efficiency) .....	64
Physical Data (English - High Efficiency).....	65
Physical Data (SI - Standard Efficiency).....	68
Physical Data (SI - High Efficiency) .....	69
Dimensions - English.....	72
Dimensions - SI.....	104
Isolator Details.....	136
Electrical Data - 2 Comp - 60Hz.....	140
Electrical Data - 3 Comp - 60Hz.....	144
Electrical Data - 4 Comp - 60Hz.....	146
Electrical Data - 4 Comp - 50Hz.....	150
Electrical Notes.....	152
Power Wiring.....	153
Typical Control Wiring - Two Compressor.....	158
Typical Control Wiring - Three Compressor .....	160
Typical Control Wiring - Four Compressor.....	164
Application Data .....	168
Guide Specifications .....	169

## YORK YCAV Air Cooled Screw Liquid Chillers

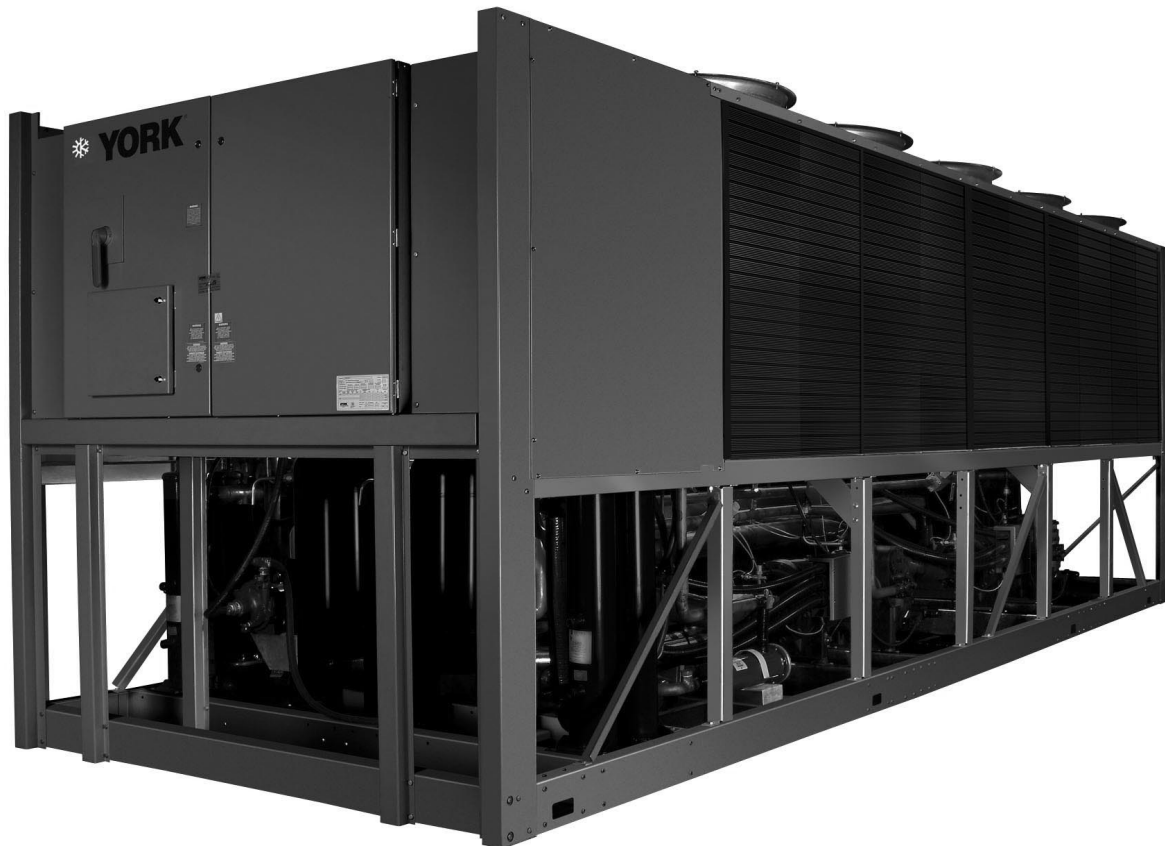

***Johnson Controls** has a proud history of innovation in both compressor design and variable-speed drive (VSD) technology. The Latitude™ air-cooled chiller uses the best of modern screw compressor design and manufacturing techniques and combines them with the latest in a long line of chiller variable-speed drives. The result is superior control and industry leading efficiency at real world conditions. In addition, by slowing the speed of the chiller to match system requirements at off-design conditions, the chiller sound output is reduced when it is the most sensitive to neighbors – evenings and weekends.*

*With the introduction of the **YORK** YCAV model air-cooled chiller, system designers are given the Latitude to design around the traditional benefits of air-cooled chillers and still offer building owners energy efficient system design. In the past, the choice to use an air-cooled chiller came with the expectation of compromise, where simplicity of design and maintenance were traded for performance and efficiency. Now combining the best of both worlds can provide a design that truly delivers the lowest total cost of ownership.*

# Specifications

---

## POWER AND ELECTRICAL

- Johnson Controls has over 25 years of experience designing variable-speed drives specifically for chiller applications. The result is an extremely reliable air-cooled chiller system that offers industry leading efficiency at real world operating conditions, valve-less compressor loading/unloading, excellent capacity control, high power factor and soft start.
- VSD Power/Control Panel includes main power connection(s), VSD and fan motor contactors, current overloads, and factory wiring. Standard design includes NEMA 3R (IP55) rating, powder painted steel cabinet with hinged, latched, and gasket sealed outer doors equipped with wind struts for safer servicing.
- VSD section of power panel includes a dedicated inverter for each compressor.
- The panel includes control display access door so display and control features can be accessed without opening main cabinet doors.
- Two and three compressor models (60 Hz only) come standard with single point power connection. Four compressor models (50 and 60 Hz) have multi-point power connections as standard. In addition, all models are supplied with a factory mounted and wired control transformer that will supply all unit control voltage from the main unit power supply. The transformer utilizes scheduled line voltage on the primary side and provides 115V/1Ø on secondary.
- Short Circuit Withstand Rating of the chiller electrical enclosure is 30,000 amps for standard terminal block connection. Ratings in accordance with UL508. (See Accessories and Options section: Can be increased to 200V & 230V: 100,000 amps, 380 & 460V: 65,000 amps, 575V: 42,000 amps).
- Compressor motors are regulated by a variable-speed drive. Therefore, motor current never exceeds the rated load amps (RLA), providing soft starts with no electrical inrush. This eliminates the motor heating and stress always found with conventional motor starters. In addition, by eliminating the heat build up during starting, the required off-time between starts is reduced to a maximum of two minutes.
- The U.S. Department of Energy (D.O.E.) states that many utility companies charge an additional fee if power factor is below 0.95. These power factor adjustments/penalties can affect both regular tariff rates, as well as demand charges. All YCAV models have a full load displacement power factor of 95% and maintain

this level throughout the operating range. Specifications should always require the installing contractor to be responsible for additional cost to furnish and install power factor correction capacitors if they are not factory mounted and wired.

## SEMI-HERMETIC YORK TWIN SCREW COMPRESSORS

Johnson Controls Engineered Systems' Chiller Design Team has developed a world class compressor with unequaled performance:

- Continuous function, microprocessor controlled, VSD provides valveless, smooth capacity control from 100% down to 10% of chiller capacity for two compressor chillers, 100% down to 7.5% for three compressor chillers, and 100% down to 5% in four compressor chillers. In addition, elimination of the slide valve and associated unloading components resulted in a 50% reduction in compressor moving parts.
- Compressors are direct drive, semi-hermetic, rotary twin-screw type, including: muffler, temperature actuated 'off-cycle' heater, rain-tight terminal box, discharge shut-off service valve, and precision machined cast iron housing mounted on elastomeric isolators.
- Reliable suction gas cooled, high efficiency, accessible hermetic compressor motor, full suction gas flow through 0.006" maximum mesh screen, with inherent internal thermal overload protection and external current overload on all three phases.
- Suction gas screen and serviceable, 0.5 micron full flow oil filter within the compressor housing.
- Cast iron compressor housing precisely machined for optimal clearances and superb efficiency. Entire compressor, from suction to discharge has a Design Working Pressure of 380 psig (26 barg) or higher.

## REFRIGERANT CIRCUIT

- Independent refrigerant circuits per compressor, each using copper refrigerant pipe formed on computer controlled bending machines. This eliminates over 60% of system piping brazed joints as compared to designs that use fittings, resulting in a highly reliable and leak resistant system.
- Liquid line components include: liquid line shut-off valve with charging port, low side pressure relief device, high absorption removable core filter-drier, sight



glass with moisture indicator, and electronic expansion valve.

- Discharge line provided with manual compressor shutoff service valve (See Options and Accessories for suction line valve). Suction line equipped with closed-cell insulation.
- External oil separators with no moving parts, 450 psig (31 barg) design working pressure, and UL listing. Refrigerant system differential pressure provides oil flow through service replaceable, 0.5 micron, full flow, cartridge-type oil filter internal to compressor.
- Oil cooling provided by dedicated air-cooled finned tube type heat exchanger located in the condenser section of the machine.

## EVAPORATOR

- High efficiency, direct-expansion type cooler with refrigerant in tubes and chilled liquid through the baffled shell. Independent circuits provided for each compressor.
- Design working pressure of the shell waterside is 150 psig (10.3 barg), and 235 psig (16 barg) for the refrigerant side. Constructed and tested in accordance with applicable sections of ASME Pressure Vessel Code, Section VIII, Division (1). Water side exempt per paragraph U-1, (C), (6).
- Removable heads allow access to internally-enhanced, seamless, copper tubes. Water vent and drain connections included.
- Cooler equipped with thermostatically controlled heater for protection to -20°F (-29°C) ambient, and shell is covered with 3/4" (19mm), flexible, closed-cell insulation, thermal conductivity of 0.26k maximum.
- Water nozzles with grooves for mechanical couplings, and insulated by Contractor after pipe installation.

## CONDENSER SECTION

- Fin and tube condenser coils of seamless, internally enhanced, high condensing coefficient, corrosion resistant copper tubes arranged in staggered rows and mechanically bonded to corrosion resistant aluminum alloy fins with full height fin collars. Design working pressure is 450 psig (31 barg).
- Low Sound Fans are provided standard on all models. Fans are dynamically and statically balanced, direct

drive, corrosion resistant glass fiber reinforced composite blades molded into low noise, full airfoil cross section, providing vertical air discharge from extended orifices. Guards of heavy gauge, PVC (polyvinyl chloride) coated.

- Condenser fan motors are high efficiency, direct drive, 3-phase, Class-"F" insulation, current overload protected, totally enclosed (TEAO) type with double sealed, permanently lubricated, ball bearings.

## MICROPROCESSOR CONTROLS

- Microprocessor control system provides automatic control of chiller operation including compressor start/stop and load/unload, anti-recycle timers, condenser fans, evaporator pump, evaporator heater, unit alarm contacts and run signal contacts.
- Chiller automatically resets to normal chiller operation after power failure.
- Unit operating software is stored in non-volatile memory. Field programmed set points are retained in lithium battery backed real time clock (RTC) memory for minimum 5 years.
- Alarm contacts are provided to remote alert contacts for any unit or system safety fault.
- Display and Keypad:
  - ◆ 80 character liquid crystal display that is both viewable in direct sunlight and has LED backlighting for nighttime viewing. The display is rated for 200 nits. One keypad and display panel is provided with every chiller.
  - ◆ Display and keypad is accessible through display access door without opening main control/electrical cabinet doors.
  - ◆ Display provides unit setpoints, status, electrical data, temperature data, pressures, safety lock-outs and diagnostics without the use of a coded display.
  - ◆ Descriptions in English (or Spanish or French), numeric data in English (or Metric) units.
  - ◆ Sealed keypad shall include unit On/Off switch.
- Programmable Setpoints (within Manufacturer limits): display language; leaving chilled liquid temperature; setpoint, control range; local or remote control; units of

# Specifications - continued

---

measure; compressor lead/lag; and maximum chilled water setpoint reset temperature range.

- Display Data: Chiller liquid return and leaving temperatures, ambient, lead compressor identification, clock and schedule, (variable) out of range, remote input indication, chilled liquid reset setpoint, and history data for last ten shutdown faults. Compressor suction, discharge, and oil pressures and temperatures, suction and discharge superheats, operating hours, starts, and anti-recycle timer status. Status Messages for manual override, unit switch off, compressor run, run permissive, remote controlled shut down, no cooling load, daily/holiday shut down, anti-recycle timer.
- During extreme or unusual conditions (i.e. blocked condenser coils, ambient above scheduled maximum, etc.) the chiller control system will avoid safety shutdown by varying the chiller controls and cooling load output to stay online and avoid safety limits being reached. This allows maximum possible cooling capacity until the unusual condition is cleared and avoids costly shutdowns. The system monitors the following parameters and maintain the maximum cooling output possible without shutdown of the equipment: motor current, suction pressure and discharge pressure.
- System Safeties are provided for individual compressor systems to perform auto-reset shut down (manual reset required after the third trip in 90 minutes). Safeties include: high discharge pressure or temperature, low suction pressure, high / low motor current, high motor temperature, high pressure switch, high / low differential oil pressure, high oil temperature, low suction superheat, critical sensor malfunction, low or high current, phase loss/single phase power, overload of motor windings, and low voltage.
- Unit Safeties are provided for the chiller to perform auto-reset shut down for the following conditions: high

or low ambient, low leaving chilled liquid temperature, under voltage, and flow switch operation.

## COMPLETE FACTORY PACKAGE

- These air-cooled chillers are shipped as a complete factory package. Each unit is completely assembled with all interconnecting refrigerant piping and internal wiring, ready for field installation:
- Each compressor is installed on its own independent refrigerant circuit, which is factory pressure tested, evacuated, then fully charged with R134a refrigerant and oil.
- After assembly, an operational test is performed with water flowing through the cooler to ensure each circuit operates correctly.
- Unit panels, structural elements, control boxes and heavy gauge structural base shall be constructed of galvanized steel. Unit panels, control boxes and structural base are finished with a baked-on powder paint. All painted surfaces shall be coated with baked on powder paint which, when subject to ASTM B117, 1,000 hour, 5% salt spray test, yields minimum ASTM 1654 rating of "6".
- Design is in accordance with applicable sections of ASME Pressure Vessel Code, NFPA 70 (National Electrical Code), U.L. and cU.L. Standards, and ASHRAE/ANSI-15 Safety Code for Mechanical Refrigeration.
- Units are Rated (all) and Certified (140 - 200 tons [492- 703 kW]) in accordance with ARI Standard 550/590-98.
- All exposed power wiring routed through liquid-tight, UV-stabilized, non-metallic conduit.

# Accessories and Options

**SOUND REDUCTION OPTIONS** - One or all options may be employed by the system designer as normally generated machine noise is considered in the overall project design:

**SilentNight™** - Standard variable speed compressors result in a chiller system that has lower part load sound values than conventional air-cooled chillers. Over 99% of chiller operating hours occur when building loads are less than design and/or ambient temperatures are less than design. As a result, all YCAV model chillers will operate with less than full load sound output nearly all the time - this is especially important on evenings and weekends when neighbors are often home. Due to time of day based sound regulations it may be desirable to force the chiller to a lower sound level on demand. The SilentNight™ control option provides a control input to limit sound output of the chiller based on time of day. This feature is programmable at the chiller panel or can be controlled remotely via signal (4-20mA or 0-10 VDC) from a BAS system. **(Factory mounted)**

**Ultra Quiet Fans** - With this option, the basic chiller is equipped with specially designed fans and motors to provide lower sound levels and retain appropriate airflow. The result is reduced fan generated noise with no adverse effect on the chiller capacity or efficiency performance. **(Factory mounted)**

**Compressor Sound Blankets** - Black, high strength, rip-resistant, two-piece acoustic compressor sound blanket. Material is both UV and mildew protected, waterproof and fire resistant (meeting California fire marshal flame specification). **(Factory mounted)**

**Acoustical perimeter enclosures** - Galvanized internal baffles are factory mounted inside of the condenser section. Perimeter enclosure panels that mount around the bottom section of the chiller to reduce sound output. Enclosures panels are painted to match unit panels and include sound insulating baffles spaced to allow for proper airflow. NOTE: The perimeter enclosures ship separately from unit **(Field mounted)**.

**CIRCUIT BREAKER** - Power panel will come equipped with a factory mounted circuit breaker at point of incoming single or multi-point connection that provides the following:

- A means to disconnect power mounted on chiller.
- Circuit breaker sized to provide the motor branch circuit protection, short circuit protection and ground fault protection for the motor branch-circuit conductors, the motor control apparatus and the motors. (Chiller mounted circuit breaker option sized for branch circuit protection eliminates the need to provide a separate

'line of sight' disconnect and separate branch circuit protection device.)

- Lockable operating handle that extends through power panel door so that power may be disconnected without opening any panel doors.
- Short Circuit Withstand Rating of the chiller electrical enclosure when using circuit breaker option is (200V & 230V: 100,000 Amps, 380 & 460V: 65,000 Amps, 575V: 42,000 Amps). Rating in accordance with UL508.

**CONDENSER COIL PROTECTION** - Standard condenser coil construction materials include aluminum fins, copper tubes, and galvanized tube supports for generally good corrosion resistance. However, these materials are not adequate for all environments. The system designer can take steps to inhibit coil corrosion in harsh applications and enhance equipment life by choosing from these options based on project design parameters and related environmental factors. **(Factory mounted)**

- **PRE-COATED FIN CONDENSER COILS** - The air-cooled condenser coils are constructed of epoxy-coated aluminum fins. This can provide corrosion resistance comparable to copper-fin coils in typical seashore locations. Either these or the post coated coils (below), are recommended for units being installed at the seashore or where salt spray may hit the unit.
- **POST-COATED EPOXY DIPPED CONDENSER COILS** - The unit is built with dipped-cured epoxy condenser coils. This is another choice for seashore and other corrosive applications (with the exception of strong alkalis, oxidizers and wet bromine, chlorine and fluorine in concentrations greater than 100 ppm).
- **COPPER FIN CONDENSER COILS** - The unit is constructed with copper tube condenser coils, which have copper fins. (This is not recommended for units in areas where they may be exposed to acid rain.)

## PROTECTIVE CHILLER PANELS:

- **Wire Panels (full unit)** - UV stabilized black polyvinyl chloride coated, heavy gauge, welded wire mesh guards mounted on the exterior of the unit. Protects condenser coil faces and prevents unauthorized access to refrigerant components (compressors, pipes, cooler, etc.), yet provides free air flow. This can cut installation cost by eliminating the need for separate, expensive fencing. **(Factory mounted)**
- **Louvered Panels (condenser coils only)** - Painted steel to match unit panels, louvered panels are mounted over the exterior condenser coil faces on the

# Accessories and Options - continued

sides of the unit to visually screen and protect coils. **(Factory mounted)**

- **Louvered Panels (full unit)** - Painted steel to match unit panels, to protect condenser coils from incidental damage, visually screen internal components, and prevent unauthorized access to internal components. **(Factory mounted)**
- **Louvered (Condensers)/Wire Panels (Mechanical)** - Louvered steel panels on external condenser coil faces, painted to match unit panels. Heavy gauge, welded wire-mesh, coated to resist corrosion, around base of machine to restrict unauthorized access. **(Factory mounted)**

## EVAPORATOR OPTIONS:

- **1-1/2" Insulation** - Double thickness insulation provided. **(Factory mounted)**
- **Raised Face Flange Accessory** for cooler nozzles:
  - ◆ 150 psig (10.3 barg), welded flanges (field kit, matching pipe flange by contractor).
  - ◆ 300 psig (20.7 barg), welded flanges (factory installed, matching pipe flange by contractor).
  - ◆ 150 psig (10.3 barg), Victaulic™ Flanges (field kit, matching pipe flange by contractor).

**FLOW SWITCH ACCESSORY** - Vaporproof SPDT, NEMA 3R switch, 150 psig (10.3 barg) DWP, 20°F to 250°F (-7°C to 121°C) with 1" NPT (IPS) connection for upright mounting in horizontal pipe (This flow switch or equivalent must be furnished with each unit). **(Field mounted)**.

**DIFFERENTIAL PRESSURE SWITCH** - Alternative to the paddle-type flow switch. 3-45 psig (0.2-3 barg) range with 1/4" NPTE pressure connections. **(Field mounted)**

**BUILDING AUTOMATION SYSTEM INTERFACE** - Chiller to accept 4 to 20mA or 0 to 10 VDC input to reset the leaving chilled liquid temperature. **(Factory mounted)**

**MULTI-UNIT SEQUENCE CONTROL** - Separate sequencing control center provided to permit control of up to eight chillers in parallel based of mixed liquid temperature (interconnecting wiring by others). **(Field mounted)**

## VIBRATION ISOLATION:

- **Elastomeric Isolation** - Recommended for normal installations. Provides very good performance in most applications for the least cost. **(Field mounted)**
- **1" Spring Isolators** - Level adjustable, spring and cage type isolators for mounting under the unit base rails. 1" nominal deflection may vary slightly by application. **(Field mounted)**
- **2" Seismic Spring Isolators** - Restrained Spring-Flex Mountings incorporate a rugged welded steel housing with vertical and horizontal limit stops. Housings designed to withstand a minimum 1.0g accelerated force in all directions to 2". Level adjustable, deflection may vary slightly by application. **(Field mounted)**

**BUY AMERICAN ACT COMPLIANCE** - In keeping with the "Buy America Act", products will be comprised of 50% or more U.S. content and manufactured (final assembly) in the U.S.A.

**SERVICE ISOLATION VALVE** - Service suction isolation added to unit for each refrigerant circuit. **(Factory mounted)**

**CHICAGO CODE RELIEF VALVE** - Special relief valves per Chicago code. **(Factory mounted)**

**SEQUENCE CONTROL AUTOMATIC LEAD TRANSFER** - Provided to permit control of up to eight chillers in parallel based on mixed liquid temperature **(Field mounted)**

## NOMENCLATURE

The Model Number denotes the following characteristics of the unit:

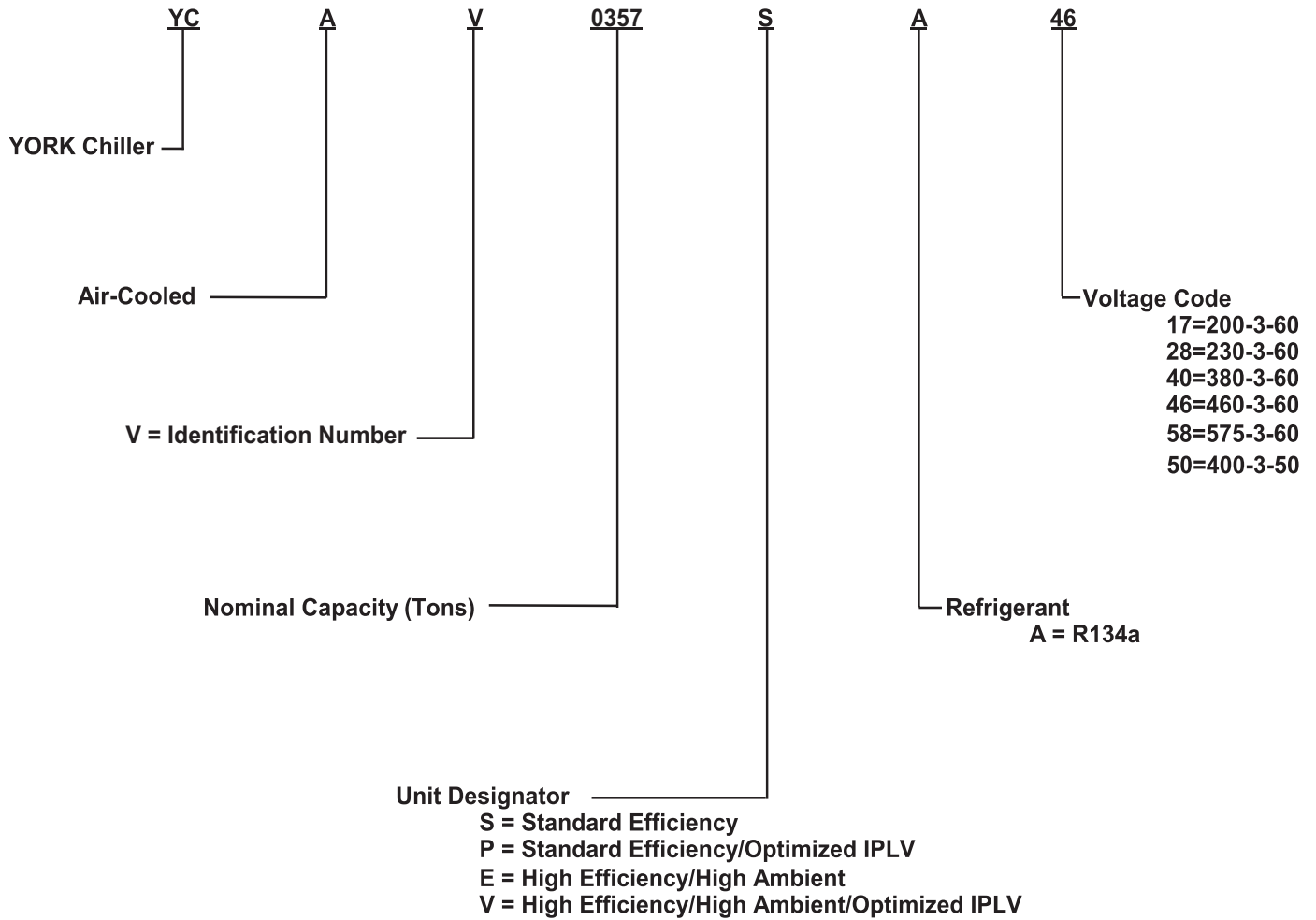



# Temperatures and Flows

## TEMPERATURE AND FLOWS (English Units)

MODEL NUMBER YCAV		LEAVING WATER TEMPERATURE (°F)		COOLER <sup>3</sup> FLOW (GPM)		AIR ON CONDENSER (°F)	
60HZ	50HZ	MIN. <sup>1</sup>	MAX. <sup>2</sup>	MIN.	MAX.	MIN.	MAX
0157(S/P)	–	40	60	140	675	0	125
0157(E/V)	–	40	60	160	750	0	125
0177(S/P/E/V)	–	40	60	160	750	0	125
0187(S/P/E/V)	–	40	60	160	750	0	125
0197(E/V)	–	40	60	180	750	0	125
0207(S/P)	–	40	60	180	800	0	125
0207(E/V)	–	40	60	180	750	0	125
0227(S/P)	–	40	60	180	800	0	125
0227(E/V)	–	40	60	180	750	0	125
0247(S/P/E/V)	–	40	60	180	800	0	125
0267(S/P)	–	40	60	180	800	0	125
0267(E/V)	–	40	60	250	1200	0	125
0287(S/P/E/V)	–	40	60	250	1200	0	125
0307(S/P)	–	40	60	300	1200	0	125
0327(E/V)	–	40	60	300	1200	0	125
0357(S/P/E/V)	–	40	60	300	1200	0	125
0397(S/P)	–	40	60	300	1200	0	125
0397(E/V)	1429 (E/V)	40	60	350	1250	0	125
0417(S/P)	1549 (S/P)	40	60	350	1250	0	125
0417(E/V)	1549 (E/V)	40	60	400	1400	0	125
0457(S/P)	1649 (S/P)	40	60	350	1250	0	125
0477(S/P/E/V)	1739 (S/P/E/V)	40	60	400	1400	0	125
0507(S/P)	1829 (S/P)	40	60	400	1400	0	125
0527(S/P)	1909 (S/P)	40	60	400	1400	0	125

### NOTES:

1. For leaving brine temperature below 40°F (4.4°C), contact your nearest Johnson Controls office for application requirements.
2. For leaving water temperature higher than 60°F (15.6°C), contact the nearest Johnson Controls office for application guidelines.
3. The evaporator is protected against freezing to -20°F (-28.8°C) with an electric heater as standard.

## TEMPERATURE AND FLOWS (SI Units)

MODEL NUMBER YCAV		LEAVING WATER TEMPERATURE (°C)		COOLER <sup>3</sup> FLOW (l/s)		AIR ON CONDENSER (°C)	
60HZ	50HZ	MIN. <sup>1</sup>	MAX. <sup>2</sup>	MIN.	MAX.	MIN.	MAX
0157(S/P)	–	4.4	15.6	8.8	42.6	-17.8	51.7
0157(E/V)	–	4.4	15.6	10.1	47.3	-17.8	51.7
0177(S/P/E/V)	–	4.4	15.6	10.1	47.3	-17.8	51.7
0187(S/P/E/V)	–	4.4	15.6	10.1	47.3	-17.8	51.7
0197(E/V)	–	4.4	15.6	11.4	47.3	-17.8	51.7
0207(S/P)	–	4.4	15.6	11.4	50.5	-17.8	51.7
0207(E/V)	–	4.4	15.6	11.4	47.3	-17.8	51.7
0227(S/P)	–	4.4	15.6	11.4	50.5	-17.8	51.7
0227(E/V)	–	4.4	15.6	11.4	47.3	-17.8	51.7
0247(S/P/E/V)	–	4.4	15.6	11.4	50.5	-17.8	51.7
0267(S/P)	–	4.4	15.6	11.4	50.5	-17.8	51.7
0267(E/V)	–	4.4	15.6	15.8	75.7	-17.8	51.7
0287(S/P/E/V)	–	4.4	15.6	15.8	75.7	-17.8	51.7
0307(S/P)	–	4.4	15.6	18.9	75.7	-17.8	51.7
0327(E/V)	–	4.4	15.6	18.9	75.7	-17.8	51.7
0357(S/P/E/V)	–	4.4	15.6	18.9	75.7	-17.8	51.7
0397(S/P)	–	4.4	15.6	18.9	75.7	-17.8	51.7
0397(E/V)	1429 (E/V)	4.4	15.6	22.1	78.9	-17.8	51.7
0417(S/P)	1549 (S/P)	4.4	15.6	22.1	78.9	-17.8	51.7
0417(E/V)	1549 (E/V)	4.4	15.6	25.2	88.3	-17.8	51.7
0457(S/P)	1649 (S/P)	4.4	15.6	22.1	78.9	-17.8	51.7
0477(S/P/E/V)	1739 (S/P/E/V)	4.4	15.6	25.2	88.3	-17.8	51.7
0507(S/P)	1829 (S/P)	4.4	15.6	25.2	88.3	-17.8	51.7
0527(S/P)	1909 (S/P)	4.4	15.6	25.2	88.3	-17.8	51.7

**NOTES:**

1. For leaving brine temperature below 4.4°C, contact your nearest Johnson Controls office for application requirements.
2. For leaving water temperature higher than 15.6°C, contact the nearest Johnson Controls office for application guidelines.
3. The evaporator is protected against freezing to -28.8°C with an electric heater as standard.

# Water Pressure Drop

## Pressure Drop Through Two Circuit YCAV Evaporators (Eng)

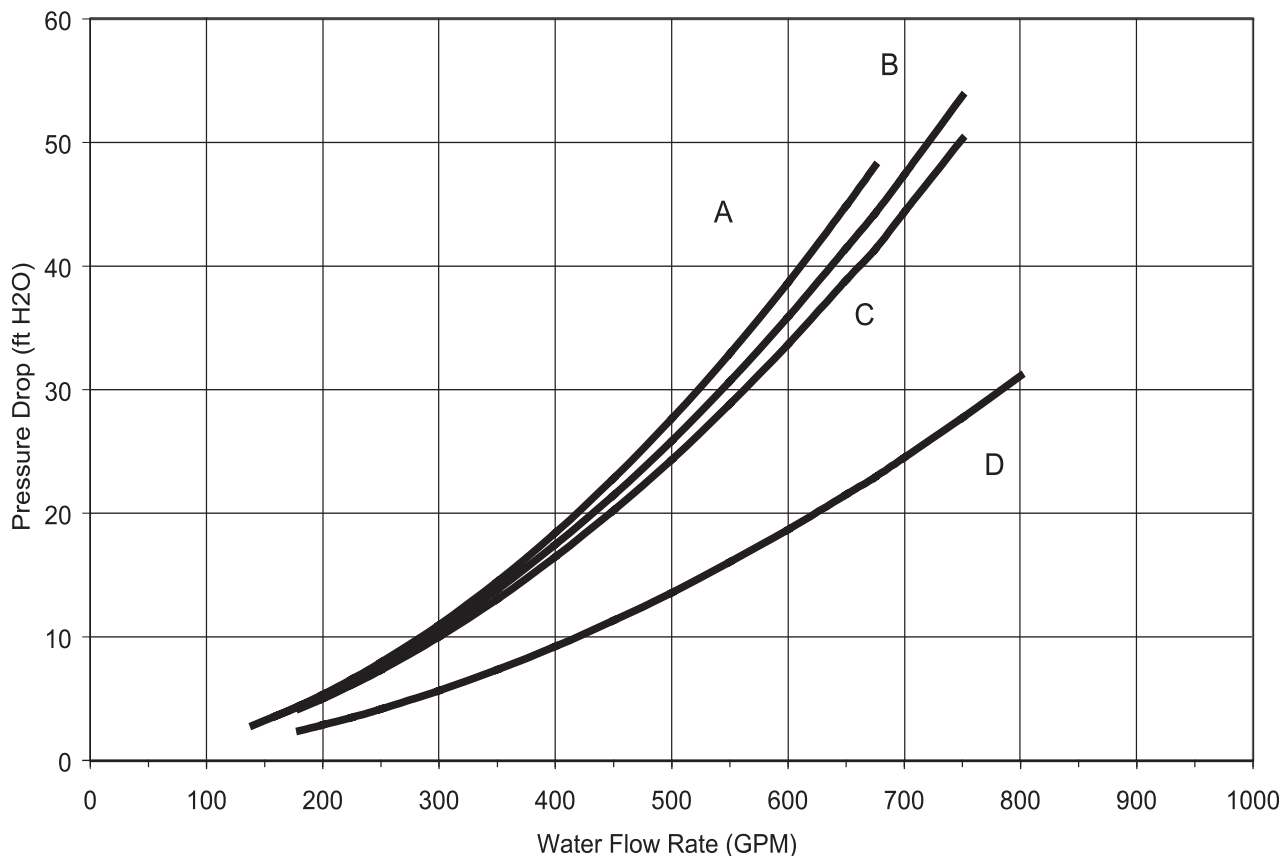

COOLER	MODEL NUMBER YCAV
A	0157(S/P)
	0157(E/V)
B	0177(S/P/E/V)
	0187(S/P/E/V)
C	0197(E/V)
	0207(E/V)
	0227(E/V)
D	0207(S/P)
	0227(S/P)
	0247(S/P/E/V)
	0267(S/P)

## Pressure Drop Through Two Circuit YCAV Evaporators (SI)

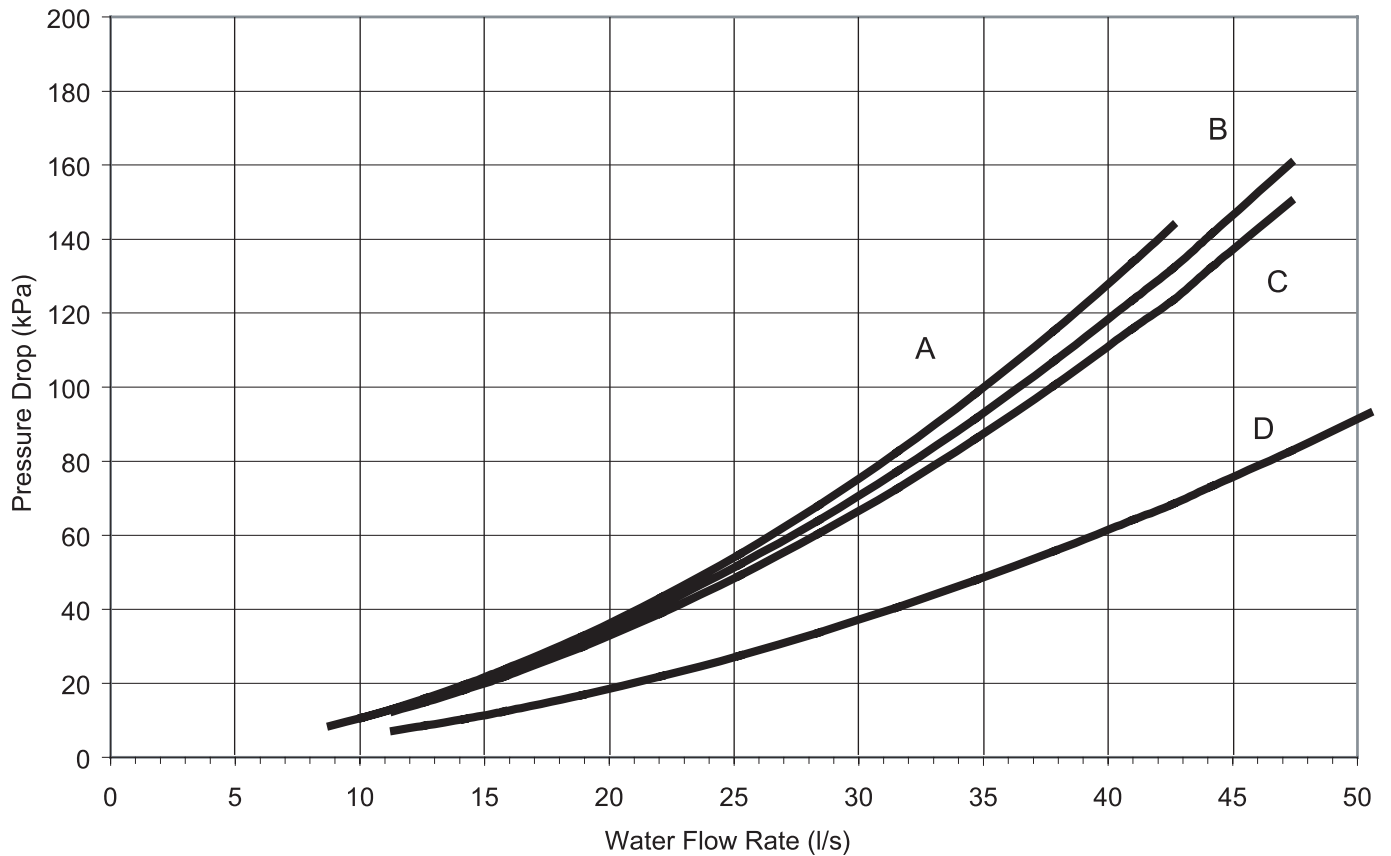

COOLER	MODEL NUMBER YCAV
A	0157(S/P)
	0157(E/V)
B	0177(S/P/E/V)
	0187(S/P/E/V)
C	0197(E/V)
	0207(E/V)
	0227(E/V)
D	0207(S/P)
	0227(S/P)
	0247(S/P/E/V)
	0267(S/P)

# Water Pressure Drop - continued

## Pressure Drop Through Three and Four Circuit YCAV Evaporators (Eng)

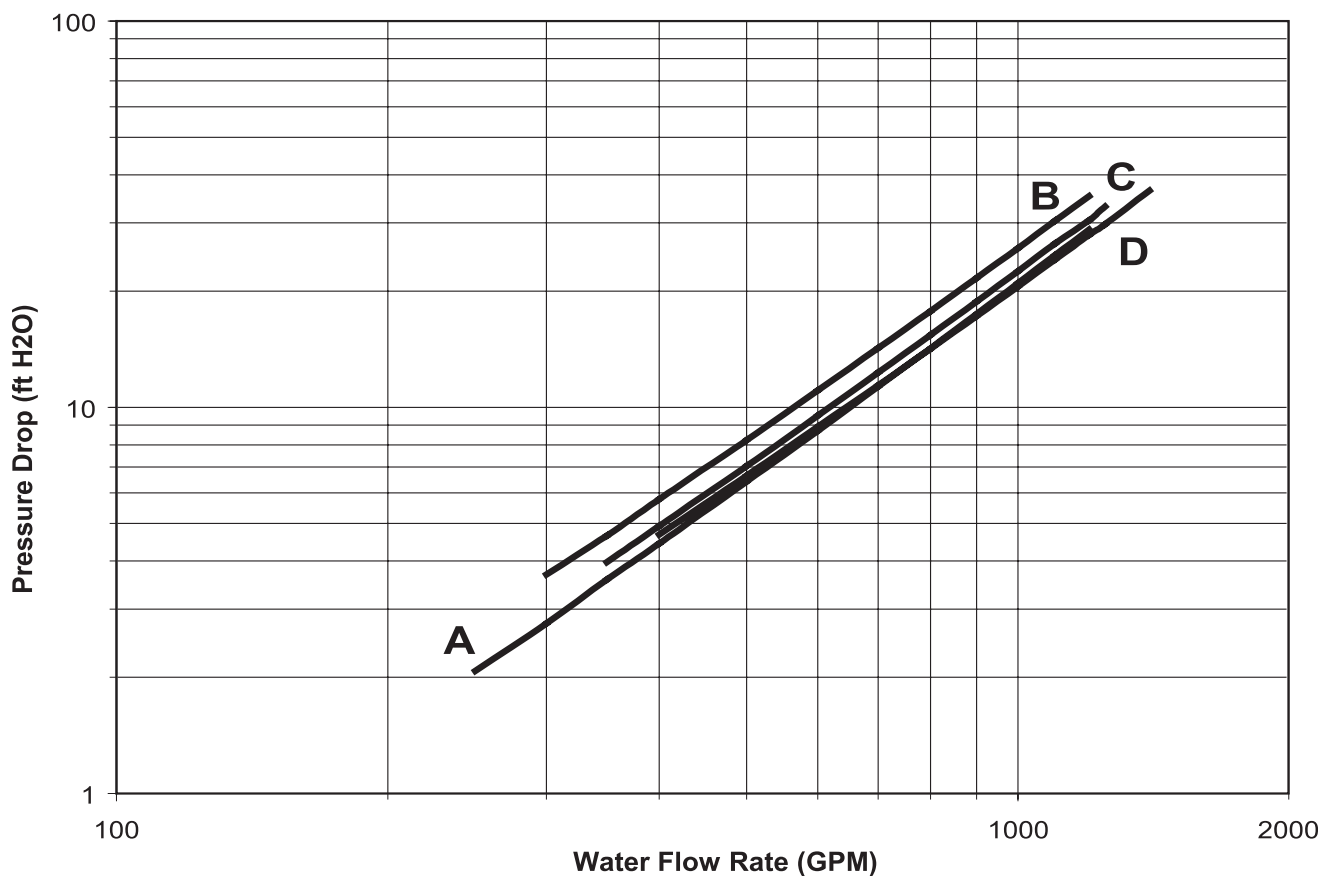

EVAP	YCAV MODELS	
	50Hz	60Hz
A	-	0267EA/VA
	-	0287SA/PA
	-	0287EA/VA
B	-	0307SA/PA
	-	0327EA/VA
	-	0357SA/PA
	-	0357EA/VA
	-	0397SA/PA
C	1429 EA/VA	0397EA/VA
	1549 SA/PA	0417SA/PA
	1649 SA/PA	0457SA/PA
D	1549 EA/VA	0417EA/VA
	1739 SA/PA	0477EA/VA
	1739 EA/VA	0477SA/PA
	1829 SA/PA	0507SA/PA
	1909 SA/PA	0527SA/PA



## Pressure Drop Through Three and Four Circuit YCAV Evaporators (SI)

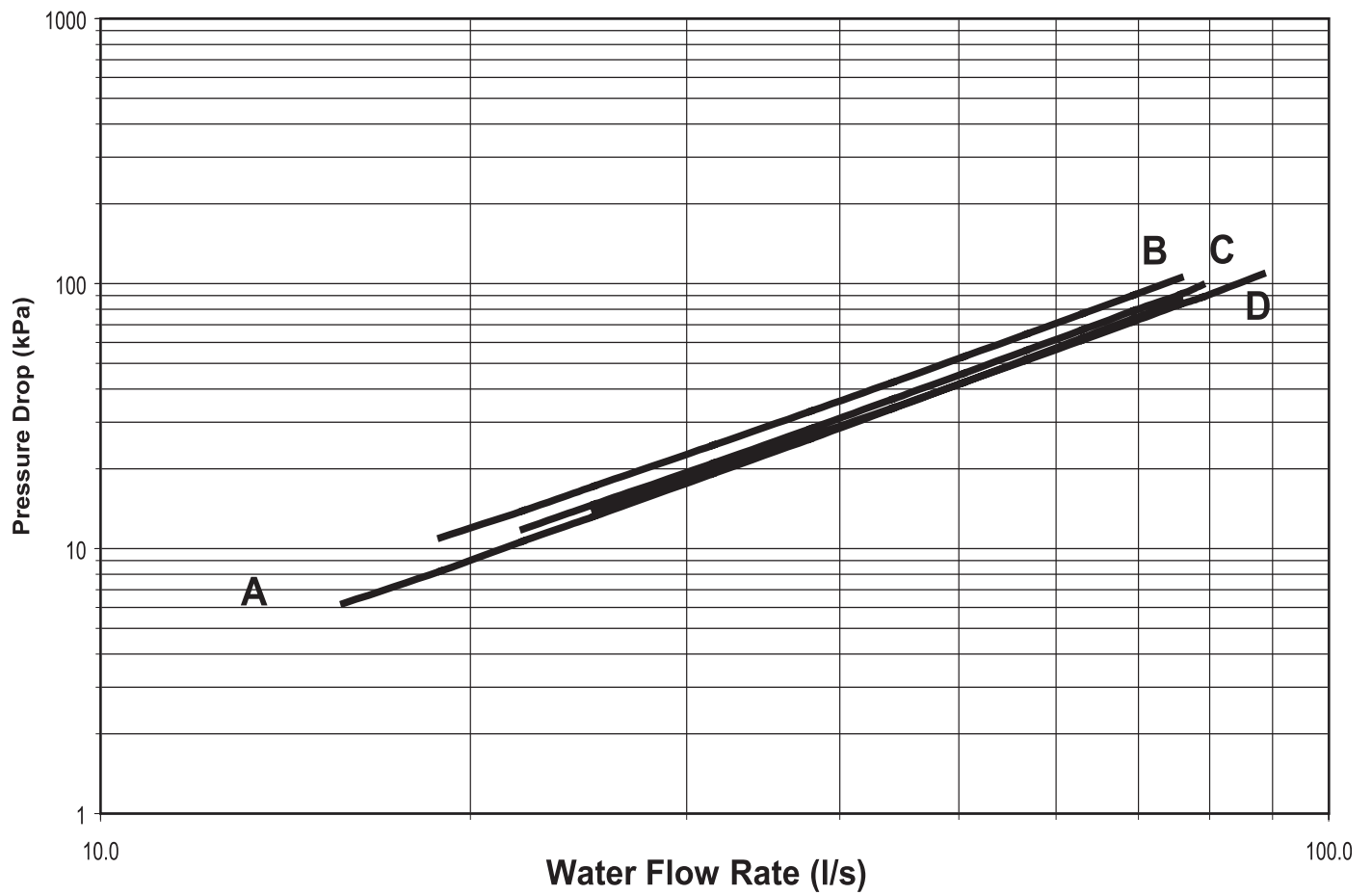

EVAP	YCAV MODELS	
	50Hz	60Hz
A	-	0267EA/VA
	-	0287SA/PA
	-	0287EA/VA
B	-	0307SA/PA
	-	0327EA/VA
	-	0357SA/PA
	-	0357EA/VA
	-	0397SA/PA
C	1429 EA/VA	0397EA/VA
	1549 SA/PA	0417SA/PA
	1649 SA/PA	0457SA/PA
D	1549 EA/VA	0417EA/VA
	1739 SA/PA	0477EA/VA
	1739 EA/VA	0477SA/PA
	1829 SA/PA	0507SA/PA
	1909 SA/PA	0527SA/PA

# Efficiency

Standard Full Load Efficiency - 60Hz				
Model Number YCAV	Nominal Capacity	Full Load	Part Load	
		EER	Standard IPLV (_S)	Optimized IPLV (_P)
0157S/P	152.6	9.6	13.2	14.5
0177S/P	168.4	9.6	13.0	14.8
0187S/P	184.2	9.8	13.1	14.9
0207S/P	197.6	9.6	13.2	14.7
0227S/P	215.3	9.9	13.0	14.7
0247S/P	236.4	9.9	12.7	14.8
0267S/P	257.6	9.9	12.3	14.9
0287S/P	272.7	9.8	13.0	14.7
0307S/P	302.9	9.8	12.6	14.6
0357S/P	342.9	9.9	13.5	15.1
0397S/P	385.3	9.9	13.2	15.2
0417S/P	409.9	9.8	12.5	14.8
0457S/P	439.3	9.8	12.8	14.8
0477S/P	471.0	9.9	12.8	14.7
0507S/P	492.1	9.9	12.5	14.7
0527S/P	513.2	9.9	11.7	14.7

**NOTES:**

1. Nominal Capacity based on 95°F air on condenser temperature, 44°F Leaving Chilled Water Temperature (LCWT), and 2.4 GPM cooler water per ton.
2. EER = Chiller EER (includes power from compressors, fans, and control panels 0.8 KW)

<b>High Full Load Efficiency - 60Hz</b>				
<b>Model Number YCAV</b>	<b>Nominal Capacity</b>	<b>Full Load</b>	<b>Part Load</b>	
		<b>EER</b>	<b>Standard IPLV (E)</b>	<b>Optimized IPLV (V)</b>
<b>0157E/V</b>	150.8	10.3	13.5	14.6
<b>0177E/V</b>	161.5	10.4	13.5	14.7
<b>0187E/V</b>	179.4	10.3	13.2	15.1
<b>0197E/V</b>	193.9	10.2	12.9	15.0
<b>0207E/V</b>	206.5	10.4	13.4	15.0
<b>0227E/V</b>	214.9	10.5	13.1	15.0
<b>0247E/V</b>	237.9	10.2	12.8	14.9
<b>0267E/V</b>	269.5	10.4	13.3	14.9
<b>0287E/V</b>	287.1	10.4	12.9	14.8
<b>0327E/V</b>	312.3	10.4	13.8	14.8
<b>0357E/V</b>	353.5	10.4	12.2	15.3
<b>0397E/V</b>	378.2	10.3	12.7	15.0
<b>0417E/V</b>	417.3	10.5	13.3	14.9
<b>0477E/V</b>	458.2	10.5	13.2	14.9

**NOTES:**

1. Nominal Capacity based on 95°F air on condenser temperature, 44°F Leaving Chilled Water Temperature (LCWT), and 2.4 GPM cooler water per ton.
2. EER = Chiller EER (includes power from compressors, fans, and control panels 0.8 KW)

# Standard Efficiency Ratings - English - 60Hz

MODEL: YCAV0157S/P												SA_IPLV= 13.2			PA_IPLV= 14.5			
AIR TEMPERATURE ON - CONDENSER (°F)																		
LCWT (°F)	75.0			80.0			85.0			90.0			95.0			100.0		
	TONS	KW	EER	TONS	KW	EER	TONS	KW	EER	TONS	KW	EER	TONS	KW	EER	TONS	KW	EER
40.0	149.1	131.5	12.3	148.0	141.8	11.4	146.7	152.6	10.6	145.4	164.1	9.8	143.9	176.0	9.1	142.2	189.4	8.4
42.0	153.7	132.5	12.6	152.5	142.6	11.7	151.2	153.5	10.9	149.8	165.0	10.1	148.2	177.0	9.3	146.5	190.5	8.6
44.0	158.3	133.5	12.9	157.1	143.6	12.0	155.7	154.4	11.1	154.3	165.9	10.3	152.6	177.9	9.6	150.8	191.5	8.8
45.0	160.7	134.0	13.1	159.4	144.1	12.1	158.1	154.9	11.3	156.5	166.4	10.4	154.9	178.4	9.7	153.0	192.0	8.9
46.0	163.1	134.6	13.2	161.8	144.6	12.3	160.4	155.4	11.4	158.8	166.9	10.6	157.1	178.9	9.8	155.2	192.5	9.0
48.0	167.9	135.7	13.5	166.6	145.7	12.6	165.1	156.5	11.7	163.5	167.9	10.8	161.7	180.0	10.0	159.7	193.6	9.3
50.0	172.8	137.0	13.8	171.4	146.9	12.8	169.9	157.7	11.9	168.2	169.0	11.1	166.4	181.1	10.3	164.3	194.7	9.5
52.0	177.8	138.4	14.0	176.4	148.2	13.1	174.8	158.9	12.2	173.1	170.2	11.3	171.2	182.3	10.5	168.6	195.6	9.7
55.0	185.4	140.6	14.4	184.0	150.3	13.5	182.3	160.8	12.6	180.5	172.1	11.7	178.5	184.1	10.8	175.0	196.8	10.0

MODEL: YCAV0177S/P												SA_IPLV= 13.0			PA_IPLV= 14.8			
AIR TEMPERATURE ON - CONDENSER (°F)																		
LCWT (°F)	75.0			80.0			85.0			90.0			95.0			100.0		
	TONS	KW	EER	TONS	KW	EER	TONS	KW	EER	TONS	KW	EER	TONS	KW	EER	TONS	KW	EER
40.0	165.7	144.7	12.6	164.2	156.2	11.6	162.4	168.5	10.7	160.5	181.2	9.9	158.4	194.4	9.1	154.6	205.6	8.5
42.0	170.9	145.7	12.9	169.3	157.3	11.9	167.5	169.5	11.0	165.5	182.3	10.1	163.3	195.6	9.4	159.1	206.2	8.7
44.0	176.1	146.8	13.2	174.6	158.3	12.2	172.8	170.6	11.3	170.7	183.5	10.4	168.4	196.8	9.6	163.8	206.8	8.9
45.0	178.8	147.5	13.3	177.2	158.9	12.3	175.4	171.1	11.4	173.3	184.0	10.5	171.0	197.5	9.7	166.1	207.1	9.0
46.0	181.5	148.2	13.5	179.9	159.5	12.5	178.1	171.7	11.5	175.9	184.6	10.7	173.5	197.8	9.9	168.5	207.3	9.2
48.0	186.9	149.5	13.8	185.4	160.8	12.8	183.5	173.0	11.8	181.3	185.9	10.9	178.4	198.3	10.1	173.3	207.9	9.4
50.0	192.4	151.0	14.0	190.8	162.2	13.0	189.0	174.3	12.1	186.7	187.2	11.2	183.4	198.8	10.4	178.2	208.4	9.6
52.0	198.0	152.6	14.3	196.4	163.7	13.3	194.5	175.8	12.3	192.2	188.6	11.4	188.5	199.4	10.6	183.1	209.0	9.9
55.0	206.4	155.2	14.7	204.9	166.1	13.7	202.9	178.1	12.7	200.6	190.9	11.8	196.2	200.4	11.0	190.7	209.9	10.2

MODEL: YCAV0187S/P												SA_IPLV= 13.1			PA_IPLV= 14.9			
AIR TEMPERATURE ON - CONDENSER (°F)																		
LCWT (°F)	75.0			80.0			85.0			90.0			95.0			100.0		
	TONS	KW	EER	TONS	KW	EER	TONS	KW	EER	TONS	KW	EER	TONS	KW	EER	TONS	KW	EER
40.0	180.3	156.2	12.6	178.8	168.2	11.7	177.1	181.1	10.8	175.3	194.7	10.0	173.4	208.9	9.3	171.1	224.9	8.6
42.0	185.9	157.4	12.9	184.4	169.4	12.0	182.6	182.3	11.1	180.7	195.8	10.3	178.7	210.1	9.5	176.4	226.2	8.8
44.0	191.7	158.8	13.2	190.0	170.7	12.3	188.2	183.5	11.4	186.3	197.1	10.5	184.2	211.3	9.8	181.7	227.5	9.0
45.0	194.6	159.6	13.4	192.9	171.4	12.4	191.1	184.2	11.5	189.1	197.7	10.7	186.9	212.0	9.9	184.3	228.0	9.1
46.0	197.5	160.4	13.5	195.8	172.1	12.5	193.9	184.9	11.6	191.9	198.4	10.8	189.7	212.7	10.0	186.9	228.3	9.2
48.0	203.5	162.1	13.8	201.7	173.7	12.8	199.8	186.3	11.9	197.6	199.8	11.0	195.3	214.1	10.2	191.9	228.9	9.4
50.0	209.5	163.8	14.1	207.7	175.3	13.1	205.7	187.8	12.2	203.5	201.3	11.3	201.1	215.5	10.5	196.8	229.3	9.7
52.0	215.7	165.8	14.3	213.8	177.1	13.3	211.7	189.5	12.4	209.4	202.8	11.5	206.9	217.0	10.7	201.9	229.8	9.9
55.0	225.2	169.0	14.7	223.2	180.0	13.7	221.0	192.2	12.8	218.6	205.4	11.9	215.9	219.6	11.0	209.6	230.6	10.2

**NOTES:**

1. kW = Compressor Input Power
2. EER = Chiller EER (includes power from compressors, fans, and control panels 0.8 KW)
3. LCWT = Leaving Chilled Water Temperature
4. Ratings based on 2.4 GPM cooler water per ton
5. Rated in accordance with ARI Standard 550/590-98
6. Certified in accordance with the ARI Water-Chilling Packages Using the Vapor Compression Cycle Certification Program, which is based on ARI Standard 550/590.

**MODEL: YCAV0157S/P** SA\_IPLV= 13.2 PA\_IPLV= 14.5

## AIR TEMPERATURE ON - CONDENSER (°F)

LCWT (°F)	105.0			110.0			115.0			120.0			125.0		
	TONS	KW	EER	TONS	KW	EER	TONS	KW	EER	TONS	KW	EER	TONS	KW	EER
40.0	138.9	202.0	7.7	136.4	216.0	7.1	132.7	229.5	6.6	116.1	208.9	6.3	90.8	163.2	6.2
42.0	142.7	202.7	7.9	139.9	217.0	7.3	136.1	230.5	6.7	117.7	204.5	6.5	92.0	159.5	6.4
44.0	146.5	203.4	8.1	143.6	217.8	7.5	139.6	231.3	6.8	119.1	200.0	6.7	93.2	155.8	6.6
45.0	148.4	203.7	8.2	145.5	218.2	7.5	141.4	231.8	6.9	119.8	197.7	6.8	93.8	154.0	6.7
46.0	150.4	204.0	8.3	147.4	218.5	7.6	143.2	232.3	7.0	120.5	195.4	6.9	94.4	152.1	6.8
48.0	154.3	204.7	8.5	151.2	219.3	7.8	146.9	233.2	7.1	121.9	190.9	7.2	95.5	148.5	7.1
50.0	158.2	205.4	8.7	155.0	220.0	8.0	148.9	228.5	7.4	123.3	186.4	7.4	96.7	144.9	7.3
52.0	162.2	206.1	8.9	158.9	220.7	8.1	150.6	222.7	7.7	124.7	182.1	7.7	97.8	141.4	7.6
55.0	168.3	207.2	9.2	164.9	221.8	8.4	153.1	214.2	8.1	126.5	175.6	8.0	99.4	136.3	8.0

**MODEL: YCAV0177S/P** SA\_IPLV= 13.0 PA\_IPLV= 14.8

## AIR TEMPERATURE ON - CONDENSER (°F)

LCWT (°F)	105.0			110.0			115.0			120.0			125.0		
	TONS	KW	EER	TONS	KW	EER	TONS	KW	EER	TONS	KW	EER	TONS	KW	EER
40.0	149.9	214.6	7.9	146.6	225.5	7.4	131.6	208.8	7.1	107.9	173.6	6.9	83.9	135.4	6.8
42.0	154.0	215.3	8.1	150.7	226.2	7.5	133.2	204.3	7.3	109.2	169.4	7.2	84.9	132.3	7.0
44.0	158.3	215.8	8.3	154.7	227.0	7.7	135.0	200.0	7.6	110.6	165.3	7.4	86.0	129.1	7.2
45.0	160.5	216.0	8.4	156.8	227.3	7.8	135.8	197.7	7.7	111.2	163.2	7.6	86.5	127.6	7.4
46.0	162.6	216.2	8.5	158.9	227.6	7.9	136.5	195.4	7.8	111.9	161.2	7.7	87.0	126.1	7.5
48.0	167.0	216.6	8.7	161.6	224.4	8.2	138.0	190.9	8.1	113.1	157.2	8.0	87.9	123.1	7.7
50.0	171.5	217.0	8.9	163.6	219.4	8.4	139.3	186.1	8.4	114.3	153.3	8.2	88.0	120.0	7.9
52.0	176.0	217.4	9.1	165.5	214.4	8.7	140.6	181.5	8.7	115.4	149.3	8.5	89.8	117.3	8.2
55.0	182.9	217.9	9.5	168.2	206.9	9.2	142.5	174.8	9.1	117.0	143.9	8.9	91.2	113.3	8.6

**MODEL: YCAV0187S/P** SA\_IPLV= 13.1 PA\_IPLV= 14.9

## AIR TEMPERATURE ON - CONDENSER (°F)

LCWT (°F)	105.0			110.0			115.0			120.0			125.0		
	TONS	KW	EER	TONS	KW	EER	TONS	KW	EER	TONS	KW	EER	TONS	KW	EER
40.0	166.1	236.3	7.9	162.9	249.2	7.4	158.5	260.7	6.9	134.8	225.2	6.7	106.6	179.6	6.6
42.0	170.5	236.8	8.1	167.2	249.8	7.6	162.6	261.4	7.1	136.6	220.8	6.9	108.0	175.5	6.8
44.0	175.1	237.3	8.3	171.6	250.3	7.8	166.8	262.1	7.2	138.4	216.2	7.2	109.4	171.3	7.0
45.0	177.4	237.5	8.4	173.8	250.6	7.9	168.4	260.9	7.3	139.3	213.8	7.3	110.0	169.2	7.2
46.0	179.7	237.7	8.5	176.1	250.8	7.9	169.1	257.2	7.5	140.1	211.5	7.4	110.7	167.2	7.3
48.0	184.5	238.1	8.7	180.7	251.2	8.1	170.6	250.2	7.7	141.8	206.6	7.7	112.0	163.1	7.5
50.0	189.3	238.4	9.0	185.4	251.6	8.3	172.3	243.6	8.0	143.3	201.6	7.9	113.1	158.8	7.8
52.0	194.1	238.9	9.2	190.1	252.0	8.5	174.2	237.3	8.3	144.5	196.5	8.2	114.2	154.8	8.1
55.0	201.5	239.5	9.5	197.3	252.7	8.8	177.1	228.5	8.7	146.5	189.3	8.6	115.9	149.1	8.5

**NOTES:**

1. kW = Compressor Input Power
2. EER = Chiller EER (includes power from compressors, fans, and control panels 0.8 KW)
3. LCWT = Leaving Chilled Water Temperature
4. Ratings based on 2.4 GPM cooler water per ton
5. Rated in accordance with ARI Standard 550/590-98
6. Certified in accordance with the ARI Water-Chilling Packages Using the Vapor Compression Cycle Certification Program, which is based on ARI Standard 550/590.



# Standard Efficiency Ratings - English - 60Hz

MODEL: YCAV0207S/P												SA_IPLV= 13.2			PA_IPLV= 14.7			
AIR TEMPERATURE ON - CONDENSER (°F)																		
LCWT (°F)	75.0			80.0			85.0			90.0			95.0			100.0		
	TONS	KW	EER	TONS	KW	EER	TONS	KW	EER	TONS	KW	EER	TONS	KW	EER	TONS	KW	EER
40.0	194.8	168.3	12.7	192.9	182.2	11.7	190.9	197.4	10.8	188.7	213.5	9.9	186.4	230.3	9.1	181.9	244.1	8.4
42.0	200.9	169.6	13.1	199.0	183.3	12.0	196.8	198.2	11.1	194.6	214.3	10.2	192.1	231.2	9.4	187.1	244.4	8.7
44.0	207.2	171.2	13.3	205.2	184.5	12.3	202.9	199.3	11.4	200.5	215.2	10.4	197.6	231.3	9.6	192.4	244.6	8.9
45.0	210.4	172.0	13.5	208.3	185.2	12.5	206.0	199.8	11.5	203.6	215.7	10.6	200.4	231.4	9.8	195.0	244.7	9.0
46.0	213.6	173.0	13.6	211.5	185.9	12.6	209.1	200.4	11.6	206.6	216.3	10.7	203.2	231.5	9.9	197.8	244.8	9.1
48.0	220.2	175.1	13.9	218.0	187.6	12.9	215.5	201.8	11.9	212.9	217.5	11.0	208.9	231.7	10.2	203.3	245.0	9.4
50.0	226.9	177.4	14.1	224.5	189.6	13.2	222.0	203.5	12.2	219.2	218.9	11.2	214.8	232.1	10.4	208.8	245.0	9.6
52.0	233.7	180.1	14.4	231.3	191.8	13.4	228.6	205.3	12.4	225.7	220.5	11.5	220.7	232.5	10.7	214.2	244.6	9.9
55.0	244.3	184.7	14.7	241.7	195.6	13.8	238.8	208.5	12.8	235.4	222.5	11.9	229.8	233.6	11.1	222.4	244.2	10.3

MODEL: YCAV0227S/P												SA_IPLV= 12.9			PA_IPLV= 14.7			
AIR TEMPERATURE ON - CONDENSER (°F)																		
LCWT (°F)	75.0			80.0			85.0			90.0			95.0			100.0		
	TONS	KW	EER	TONS	KW	EER	TONS	KW	EER	TONS	KW	EER	TONS	KW	EER	TONS	KW	EER
40.0	211.3	180.4	12.9	209.4	194.3	11.9	207.3	209.2	11.0	205.1	224.8	10.2	202.7	241.3	9.4	199.9	259.8	8.7
42.0	218.0	182.0	13.2	216.0	195.7	12.2	213.8	210.5	11.3	211.4	226.2	10.4	208.9	242.7	9.7	206.0	261.3	8.9
44.0	224.9	183.7	13.5	222.7	197.3	12.5	220.4	212.0	11.6	218.0	227.7	10.7	215.3	244.2	9.9	211.9	262.1	9.1
45.0	228.3	184.7	13.6	226.2	198.2	12.6	223.8	212.8	11.7	221.3	228.5	10.8	218.5	245.1	10.0	214.7	262.2	9.2
46.0	231.8	185.7	13.7	229.6	199.1	12.8	227.2	213.7	11.8	224.6	229.3	11.0	221.8	245.9	10.1	217.5	262.2	9.4
48.0	238.9	187.8	14.0	236.7	201.1	13.0	234.2	215.4	12.1	231.4	231.0	11.2	228.5	247.5	10.4	223.2	262.4	9.6
50.0	246.2	190.1	14.3	243.8	203.1	13.3	241.2	217.4	12.4	238.4	232.8	11.5	235.3	249.2	10.6	229.0	262.5	9.8
52.0	253.6	192.7	14.5	251.2	205.4	13.6	248.5	219.5	12.6	245.5	234.9	11.7	242.3	251.2	10.8	234.9	262.7	10.1
55.0	264.9	196.7	14.9	262.4	209.2	13.9	259.5	223.0	13.0	256.4	238.2	12.1	253.1	254.3	11.2	243.9	263.0	10.5

MODEL: YCAV0247S/P												SA_IPLV= 12.7			PA_IPLV= 14.8			
AIR TEMPERATURE ON - CONDENSER (°F)																		
LCWT (°F)	75.0			80.0			85.0			90.0			95.0			100.0		
	TONS	KW	EER	TONS	KW	EER	TONS	KW	EER	TONS	KW	EER	TONS	KW	EER	TONS	KW	EER
40.0	231.8	198.8	12.8	229.8	213.8	11.9	227.6	229.8	11.0	225.2	246.7	10.2	222.7	264.4	9.4	219.7	284.3	8.7
42.0	239.1	200.6	13.1	236.9	215.6	12.1	234.6	231.5	11.3	232.1	248.4	10.4	229.5	266.1	9.7	226.4	286.1	8.9
44.0	246.5	202.6	13.4	244.3	217.4	12.4	241.9	233.3	11.5	239.2	250.2	10.7	236.4	268.0	9.9	232.9	287.5	9.1
45.0	250.2	203.7	13.5	248.0	218.4	12.6	245.5	234.3	11.7	242.8	251.2	10.8	239.9	268.9	10.0	236.1	287.8	9.2
46.0	254.0	204.8	13.7	251.7	219.4	12.7	249.2	235.2	11.8	246.5	252.1	10.9	243.5	269.9	10.1	239.2	288.2	9.4
48.0	261.7	207.1	13.9	259.4	221.6	13.0	256.7	237.3	12.0	253.9	254.1	11.2	250.8	271.9	10.4	245.7	288.9	9.6
50.0	269.6	209.5	14.2	267.1	223.9	13.2	264.4	239.5	12.3	261.4	256.2	11.4	258.2	274.0	10.6	252.2	289.6	9.8
52.0	277.6	212.2	14.4	275.1	226.4	13.5	272.2	241.9	12.5	269.1	258.5	11.7	265.8	276.2	10.8	258.9	290.4	10.1
55.0	289.9	215.9	14.8	287.2	230.3	13.9	284.2	245.7	12.9	281.0	262.2	12.0	277.4	279.7	11.2	269.0	291.7	10.4

**NOTES:**

1. kW = Compressor Input Power
2. EER = Chiller EER (includes power from compressors, fans, and control panels 0.8 KW)
3. LCWT = Leaving Chilled Water Temperature
4. Ratings based on 2.4 GPM cooler water per ton
5. Rated in accordance with ARI Standard 550/590-98 and are accordingly certified

<b>MODEL: YCAV0207S/P</b>	<b>SA_IPLV= 13.2</b>	<b>PA_IPLV= 14.7</b>
---------------------------	----------------------	----------------------

AIR TEMPERATURE ON - CONDENSER (°F)															
LCWT (°F)	105.0			110.0			115.0			120.0			125.0		
	TONS	KW	EER	TONS	KW	EER	TONS	KW	EER	TONS	KW	EER	TONS	KW	EER

LCWT (°F)	105.0			110.0			115.0			120.0			125.0		
	TONS	KW	EER	TONS	KW	EER	TONS	KW	EER	TONS	KW	EER	TONS	KW	EER
40.0	176.0	254.8	7.8	172.5	265.5	7.4	150.6	233.7	7.3	123.4	193.8	7.1	96.0	151.6	6.9
42.0	180.7	254.7	8.0	177.0	265.8	7.6	152.5	228.4	7.5	124.9	189.3	7.3	97.1	148.2	7.1
44.0	185.4	254.4	8.3	180.9	264.4	7.8	154.2	223.1	7.8	126.4	184.6	7.6	98.3	144.7	7.4
45.0	187.9	254.3	8.4	181.9	261.2	7.9	155.0	220.5	7.9	127.1	182.3	7.7	98.9	143.0	7.5
46.0	190.3	254.1	8.5	182.9	258.0	8.0	155.8	217.9	8.0	127.9	180.0	7.9	99.4	141.3	7.6
48.0	195.3	253.7	8.7	185.0	251.5	8.3	157.4	212.7	8.3	129.3	175.6	8.1	100.5	137.9	7.9
50.0	200.4	253.2	9.0	187.0	245.0	8.6	158.9	207.6	8.6	130.7	171.3	8.4	101.6	134.6	8.1
52.0	205.5	252.8	9.2	189.0	238.8	8.9	160.5	202.6	8.8	131.9	166.9	8.7	102.7	131.4	8.4
55.0	213.4	252.2	9.6	191.9	230.3	9.4	162.7	195.3	9.3	133.8	160.9	9.1	104.2	126.7	8.8

<b>MODEL: YCAV0227S/P</b>	<b>SA_IPLV= 12.9</b>	<b>PA_IPLV= 14.7</b>
---------------------------	----------------------	----------------------

AIR TEMPERATURE ON - CONDENSER (°F)															
LCWT (°F)	105.0			110.0			115.0			120.0			125.0		
	TONS	KW	EER	TONS	KW	EER	TONS	KW	EER	TONS	KW	EER	TONS	KW	EER

LCWT (°F)	105.0			110.0			115.0			120.0			125.0		
	TONS	KW	EER	TONS	KW	EER	TONS	KW	EER	TONS	KW	EER	TONS	KW	EER
40.0	193.1	269.8	8.1	189.4	281.3	7.6	184.2	290.8	7.2	156.3	250.8	7.0	123.6	199.7	6.9
42.0	198.2	270.0	8.3	194.4	281.6	7.8	189.0	291.3	7.4	158.0	245.3	7.2	125.1	194.9	7.1
44.0	203.5	270.1	8.5	199.4	281.8	8.0	192.9	289.5	7.6	159.8	239.3	7.5	126.6	190.1	7.3
45.0	206.2	270.2	8.6	202.0	281.9	8.1	193.9	286.3	7.7	160.7	236.4	7.6	127.3	187.8	7.5
46.0	208.9	270.2	8.7	204.7	282.0	8.2	194.8	283.0	7.8	161.5	233.4	7.7	128.0	185.4	7.6
48.0	214.4	270.3	9.0	210.0	282.1	8.4	196.7	276.3	8.1	163.3	227.5	8.0	129.1	180.3	7.9
50.0	219.9	270.4	9.2	215.4	282.1	8.6	198.8	269.2	8.3	164.9	222.1	8.3	130.4	175.6	8.1
52.0	225.6	270.4	9.4	220.9	282.1	8.9	200.8	262.1	8.6	166.3	216.6	8.5	131.7	171.2	8.4
55.0	234.3	270.6	9.8	229.3	282.2	9.2	203.7	251.2	9.1	168.6	208.8	9.0	133.7	165.0	8.8

<b>MODEL: YCAV0247S/P</b>	<b>SA_IPLV= 12.7</b>	<b>PA_IPLV= 14.8</b>
---------------------------	----------------------	----------------------

AIR TEMPERATURE ON - CONDENSER (°F)															
LCWT (°F)	105.0			110.0			115.0			120.0			125.0		
	TONS	KW	EER	TONS	KW	EER	TONS	KW	EER	TONS	KW	EER	TONS	KW	EER

LCWT (°F)	105.0			110.0			115.0			120.0			125.0		
	TONS	KW	EER	TONS	KW	EER	TONS	KW	EER	TONS	KW	EER	TONS	KW	EER
40.0	213.4	297.6	8.1	211.0	313.8	7.6	206.6	327.6	7.2	171.9	273.7	7.1	135.9	217.1	6.9
42.0	219.3	298.4	8.3	216.7	314.6	7.8	208.9	321.0	7.4	173.4	266.3	7.3	137.5	211.9	7.2
44.0	225.3	299.1	8.5	222.5	315.5	8.0	211.3	314.2	7.6	174.9	259.1	7.6	138.9	206.6	7.4
45.0	228.3	299.4	8.6	225.4	315.9	8.1	212.5	310.6	7.7	175.7	255.8	7.7	139.8	204.3	7.5
46.0	231.4	299.7	8.7	228.4	316.3	8.2	213.6	306.8	7.9	176.6	252.6	7.8	140.5	201.6	7.7
48.0	237.6	300.4	8.9	234.5	317.0	8.4	215.7	298.9	8.2	178.3	246.4	8.1	142.0	196.6	7.9
50.0	243.9	301.1	9.2	240.7	317.7	8.6	217.7	290.6	8.5	180.0	240.3	8.3	143.5	191.8	8.2
52.0	250.3	301.8	9.4	247.0	318.4	8.8	219.4	282.3	8.8	181.7	234.3	8.6	144.8	187.1	8.5
55.0	260.2	302.9	9.7	256.6	319.5	9.1	222.0	270.7	9.2	184.1	225.6	9.1	146.8	180.2	8.9

**NOTES:**

1. kW = Compressor Input Power
2. EER = Chiller EER (includes power from compressors, fans, and control panels 0.8 KW)
3. LCWT = Leaving Chilled Water Temperature
4. Ratings based on 2.4 GPM cooler water per ton
5. Rated in accordance with ARI Standard 550/590-98 and are accordingly certified

# Standard Efficiency Ratings - English - 60Hz

MODEL: YCAV0267S/P												SA_IPLV= 12.3			PA_IPLV= 14.9			
AIR TEMPERATURE ON - CONDENSER (°F)																		
LCWT (°F)	75.0			80.0			85.0			90.0			95.0			100.0		
	TONS	KW	EER	TONS	KW	EER	TONS	KW	EER	TONS	KW	EER	TONS	KW	EER	TONS	KW	EER
40.0	252.3	217.0	12.8	250.2	233.1	11.9	247.9	250.3	11.0	245.4	268.3	10.2	242.7	287.2	9.5	239.6	308.5	8.7
42.0	260.2	219.0	13.1	258.0	235.2	12.1	255.6	252.2	11.3	252.9	270.4	10.4	250.1	289.2	9.7	246.8	310.7	9.0
44.0	268.2	221.2	13.3	265.9	237.3	12.4	263.3	254.3	11.5	260.6	272.4	10.7	257.6	291.5	9.9	254.0	312.6	9.2
45.0	272.2	222.5	13.5	269.9	238.4	12.5	267.3	255.5	11.6	264.5	273.6	10.8	261.4	292.5	10.0	257.5	313.2	9.3
46.0	276.3	223.6	13.6	273.9	239.5	12.7	271.3	256.6	11.8	268.4	274.7	10.9	265.3	293.6	10.1	261.0	313.9	9.4
48.0	284.6	226.1	13.9	282.1	242.0	12.9	279.4	258.9	12.0	276.4	276.9	11.2	273.1	296.0	10.4	268.2	315.2	9.6
50.0	293.1	228.7	14.1	290.5	244.5	13.2	287.7	261.3	12.3	284.6	279.3	11.4	281.1	298.4	10.6	275.5	316.5	9.8
52.0	301.7	231.6	14.4	299.1	247.1	13.4	296.1	264.0	12.5	292.9	281.8	11.6	289.3	300.9	10.8	282.9	317.8	10.0
55.0	315.0	234.9	14.8	312.1	251.1	13.8	309.0	268.1	12.9	305.6	286.0	12.0	301.9	304.8	11.1	294.2	320.1	10.4

MODEL: YCAV0287S/P												SA_IPLV= 13.0			PA_IPLV= 14.7			
AIR TEMPERATURE ON - CONDENSER (°F)																		
LCWT (°F)	75.0			80.0			85.0			90.0			95.0			100.0		
	TONS	KW	EER	TONS	KW	EER	TONS	KW	EER	TONS	KW	EER	TONS	KW	EER	TONS	KW	EER
40.0	268.2	228.0	12.9	265.7	246.5	11.9	262.9	266.4	10.9	259.9	287.2	10.1	256.7	308.8	9.3	251.3	328.6	8.6
42.0	276.6	229.7	13.2	274.1	248.0	12.2	271.2	267.7	11.2	268.0	288.6	10.4	264.6	310.3	9.6	258.7	329.7	8.8
44.0	285.2	231.6	13.5	282.6	249.6	12.5	279.6	269.2	11.5	276.3	290.0	10.6	272.7	311.7	9.8	266.3	330.6	9.1
45.0	289.6	232.6	13.7	286.9	250.5	12.6	283.9	270.0	11.7	280.6	290.8	10.8	276.7	312.1	9.9	270.2	331.0	9.2
46.0	294.0	233.7	13.8	291.3	251.4	12.8	288.3	270.8	11.8	284.9	291.6	10.9	280.7	312.5	10.1	274.1	331.5	9.3
48.0	303.0	236.1	14.1	300.2	253.5	13.1	297.1	272.7	12.1	293.5	293.3	11.2	288.9	313.4	10.3	282.0	332.3	9.6
50.0	312.1	238.8	14.4	309.3	255.8	13.4	306.0	274.7	12.4	302.4	295.2	11.4	297.2	314.4	10.6	290.1	333.3	9.8
52.0	321.4	241.7	14.6	318.5	258.5	13.6	315.2	277.1	12.7	311.4	297.4	11.7	305.7	315.5	10.9	298.2	334.0	10.1
55.0	335.7	246.8	15.0	332.7	262.8	14.0	329.2	280.9	13.0	325.3	300.9	12.1	318.6	317.4	11.3	310.1	334.5	10.4

MODEL: YCAV0307S/P												SA_IPLV= 12.6			PA_IPLV= 14.6			
AIR TEMPERATURE ON - CONDENSER (°F)																		
LCWT (°F)	75.0			80.0			85.0			90.0			95.0			100.0		
	TONS	KW	EER	TONS	KW	EER	TONS	KW	EER	TONS	KW	EER	TONS	KW	EER	TONS	KW	EER
40.0	298.0	251.5	13.0	295.2	272.2	12.0	292.2	294.8	11.0	289.0	318.9	10.1	285.6	344.0	9.3	279.8	366.7	8.6
42.0	307.4	253.3	13.3	304.5	273.7	12.3	301.3	296.0	11.3	297.9	320.0	10.4	294.3	345.1	9.6	287.9	367.5	8.8
44.0	317.0	255.6	13.6	314.0	275.5	12.6	310.6	297.5	11.6	307.1	321.3	10.7	302.9	345.6	9.8	296.2	368.1	9.1
45.0	321.9	256.9	13.8	318.8	276.5	12.8	315.4	298.3	11.8	311.7	322.0	10.8	307.3	345.8	10.0	300.4	368.5	9.2
46.0	326.9	258.2	13.9	323.7	277.6	12.9	320.2	299.2	11.9	316.4	322.7	11.0	311.7	346.1	10.1	304.7	368.8	9.3
48.0	336.9	261.3	14.2	333.6	280.0	13.2	329.9	301.2	12.2	326.0	324.5	11.2	320.6	346.9	10.4	313.4	369.4	9.6
50.0	347.2	264.7	14.5	343.7	282.9	13.5	339.9	303.5	12.5	335.8	326.6	11.5	329.8	347.7	10.7	322.0	369.6	9.8
52.0	357.7	268.6	14.7	354.1	286.1	13.7	350.1	306.2	12.7	345.8	328.8	11.8	339.1	348.7	10.9	330.3	369.0	10.1
55.0	373.9	275.3	15.0	370.0	291.6	14.1	365.8	310.9	13.1	360.8	332.0	12.2	353.5	350.8	11.3	343.0	368.4	10.5

**NOTES:**

1. kW = Compressor Input Power
2. EER = Chiller EER (includes power from compressors, fans, and control panels 0.8 kW)
3. LCWT = Leaving Chilled Water Temperature
4. Ratings based on 2.4 GPM cooler water per ton
5. Rated in accordance with ARI Standard 550/590-98 and are accordingly certified

**MODEL: YCAV0267S/P** **SA\_IPLV= 12.3** **PA\_IPLV= 14.9**

## AIR TEMPERATURE ON - CONDENSER (°F)

LCWT (°F)	105.0			110.0			115.0			120.0			125.0		
	TONS	KW	EER	TONS	KW	EER	TONS	KW	EER	TONS	KW	EER	TONS	KW	EER
40.0	233.9	325.1	8.1	232.6	345.9	7.6	229.4	364.5	7.2	190.7	303.0	7.1	151.8	241.9	6.9
42.0	240.4	326.4	8.3	239.1	347.3	7.8	231.5	356.0	7.4	192.7	295.8	7.3	153.5	236.2	7.2
44.0	247.1	327.6	8.5	245.6	348.7	8.0	233.9	347.4	7.6	194.7	288.7	7.6	155.0	230.2	7.4
45.0	250.5	328.3	8.6	248.9	349.5	8.1	235.1	343.0	7.8	195.7	285.2	7.7	156.0	227.6	7.6
46.0	253.9	328.9	8.7	252.3	350.1	8.2	236.3	338.6	7.9	196.7	281.7	7.8	156.6	224.6	7.7
48.0	260.9	330.1	8.9	259.1	351.5	8.4	238.7	329.7	8.2	198.7	274.7	8.1	158.2	219.1	7.9
50.0	267.9	331.5	9.1	266.1	352.8	8.6	241.1	321.1	8.5	200.6	267.9	8.4	159.8	213.7	8.2
52.0	275.1	332.8	9.4	273.1	354.2	8.8	243.3	313.0	8.8	202.5	261.2	8.6	161.3	208.4	8.5
55.0	286.1	334.8	9.7	283.9	356.3	9.1	246.5	301.6	9.2	205.2	251.5	9.1	163.6	200.6	8.9

**MODEL: YCAV0287S/P** **SA\_IPLV= 13.0** **PA\_IPLV= 14.7**

## AIR TEMPERATURE ON - CONDENSER (°F)

LCWT (°F)	105.0			110.0			115.0			120.0			125.0		
	TONS	KW	EER	TONS	KW	EER	TONS	KW	EER	TONS	KW	EER	TONS	KW	EER
40.0	244.3	345.3	8.0	239.3	361.9	7.5	211.8	327.9	7.3	173.2	272.6	7.1	134.6	213.1	6.9
42.0	250.9	345.8	8.2	245.7	362.8	7.7	214.1	320.4	7.5	175.4	266.4	7.3	136.3	208.3	7.1
44.0	257.7	346.2	8.4	252.2	363.6	7.9	217.0	313.7	7.8	177.5	260.0	7.6	138.0	203.5	7.3
45.0	261.2	346.3	8.5	255.5	363.8	8.0	218.3	310.2	7.9	178.6	256.9	7.7	138.8	201.1	7.5
46.0	264.7	346.4	8.6	257.2	360.2	8.1	219.5	306.6	8.0	179.6	253.7	7.8	139.6	198.7	7.6
48.0	271.7	346.6	8.9	260.1	351.7	8.4	221.8	299.5	8.3	181.7	247.5	8.1	141.2	194.0	7.8
50.0	278.9	346.7	9.1	263.2	343.4	8.6	224.0	292.4	8.6	183.7	241.5	8.4	142.7	189.4	8.1
52.0	286.2	346.8	9.3	266.3	335.4	8.9	226.2	285.4	8.8	185.6	235.5	8.7	144.2	184.9	8.4
55.0	297.4	346.9	9.7	270.7	323.9	9.4	229.3	275.1	9.3	188.1	226.8	9.1	146.4	178.4	8.8

**MODEL: YCAV0307S/P** **SA\_IPLV= 12.6** **PA\_IPLV= 14.6**

## AIR TEMPERATURE ON - CONDENSER (°F)

LCWT (°F)	105.0			110.0			115.0			120.0			125.0		
	TONS	KW	EER	TONS	KW	EER	TONS	KW	EER	TONS	KW	EER	TONS	KW	EER
40.0	271.4	384.3	8.0	266.1	400.6	7.5	231.7	351.8	7.4	189.6	291.6	7.2	147.3	228.1	7.0
42.0	278.6	384.1	8.2	273.1	401.0	7.7	234.3	343.4	7.7	191.9	284.9	7.5	149.2	222.9	7.3
44.0	286.0	383.8	8.4	278.5	397.4	7.9	237.3	335.8	7.9	194.2	278.0	7.7	150.9	217.7	7.5
45.0	289.7	383.6	8.5	280.0	392.6	8.1	238.6	331.9	8.1	195.4	274.6	7.9	151.8	215.2	7.6
46.0	293.5	383.3	8.7	281.5	387.8	8.2	239.8	328.1	8.2	196.5	271.2	8.0	152.7	212.7	7.8
48.0	301.2	382.7	8.9	284.7	378.1	8.5	242.5	320.7	8.5	198.7	264.5	8.3	154.4	207.6	8.0
50.0	309.0	382.1	9.1	287.9	368.4	8.8	244.7	312.7	8.7	200.9	258.0	8.6	156.1	202.7	8.3
52.0	317.0	381.4	9.4	291.1	359.1	9.1	247.1	305.2	9.0	202.9	251.7	8.8	157.7	197.8	8.6
55.0	329.2	380.5	9.8	295.5	346.4	9.6	250.5	294.2	9.5	205.7	242.4	9.3	160.0	190.8	9.0

**NOTES:**

1. kW = Compressor Input Power
2. EER = Chiller EER (includes power from compressors, fans, and control panels 0.8 KW)
3. LCWT = Leaving Chilled Water Temperature
4. Ratings based on 2.4 GPM cooler water per ton
5. Rated in accordance with ARI Standard 550/590-98 and are accordingly certified

# Standard Efficiency Ratings - English - 60Hz

MODEL: YCAV0357S/P												SA_IPLV= 13.5			PA_IPLV= 15.1			
AIR TEMPERATURE ON - CONDENSER (°F)																		
LCWT (°F)	75.0			80.0			85.0			90.0			95.0			100.0		
	TONS	KW	EER	TONS	KW	EER	TONS	KW	EER	TONS	KW	EER	TONS	KW	EER	TONS	KW	EER
40.0	336.3	288.0	12.8	333.4	309.9	11.9	330.1	333.5	11.0	326.6	358.2	10.2	322.9	384.1	9.4	318.6	413.2	8.7
42.0	346.9	290.6	13.1	343.8	312.4	12.2	340.4	335.8	11.3	336.7	360.5	10.4	332.8	386.5	9.7	328.3	415.8	8.9
44.0	357.7	293.3	13.4	354.5	315.0	12.4	350.9	338.3	11.5	347.1	363.1	10.7	342.9	389.0	9.9	338.1	418.1	9.1
45.0	363.2	294.8	13.6	359.9	316.4	12.6	356.3	339.6	11.7	352.3	364.3	10.8	348.1	390.4	10.0	342.7	418.5	9.2
46.0	368.8	296.5	13.7	365.4	317.8	12.7	361.7	341.0	11.8	357.6	365.7	10.9	353.3	391.7	10.1	347.2	418.9	9.3
48.0	380.1	299.7	14.0	376.6	320.9	13.0	372.7	343.8	12.1	368.5	368.5	11.2	363.9	394.5	10.4	356.5	419.7	9.6
50.0	391.6	303.2	14.2	387.9	324.2	13.3	383.9	347.0	12.3	379.5	371.4	11.4	374.8	397.4	10.6	366.0	420.5	9.8
52.0	403.4	307.0	14.5	399.6	327.7	13.5	395.4	350.3	12.6	390.8	374.5	11.7	385.9	400.4	10.8	375.7	421.3	10.1
55.0	421.3	312.6	14.9	417.2	333.5	13.9	412.9	355.6	13.0	408.1	379.9	12.0	402.9	405.5	11.2	390.4	422.8	10.4

MODEL: YCAV0397S/P												SA_IPLV= 13.2			PA_IPLV= 15.2			
AIR TEMPERATURE ON - CONDENSER (°F)																		
LCWT (°F)	75.0			80.0			85.0			90.0			95.0			100.0		
	TONS	KW	EER	TONS	KW	EER	TONS	KW	EER	TONS	KW	EER	TONS	KW	EER	TONS	KW	EER
40.0	377.3	324.5	12.8	374.2	348.7	11.9	370.7	374.4	11.0	366.9	401.4	10.2	362.9	429.8	9.5	358.2	461.7	8.7
42.0	389.1	327.5	13.1	385.8	351.6	12.1	382.2	377.3	11.3	378.2	404.5	10.4	374.0	432.8	9.7	369.0	464.8	8.9
44.0	401.2	330.7	13.3	397.8	354.8	12.4	394.0	380.3	11.5	389.8	407.5	10.7	385.3	436.0	9.9	380.1	468.1	9.2
45.0	407.4	332.4	13.5	403.8	356.4	12.5	399.9	382.1	11.6	395.7	409.1	10.8	391.0	437.7	10.0	385.4	469.1	9.3
46.0	413.5	334.3	13.6	410.0	358.1	12.7	406.0	383.7	11.8	401.6	410.9	10.9	396.9	439.3	10.1	390.7	470.2	9.4
48.0	426.1	337.9	13.9	422.4	361.6	12.9	418.2	387.1	12.0	413.7	414.2	11.2	408.7	442.9	10.4	401.5	472.0	9.6
50.0	439.0	341.8	14.2	435.1	365.5	13.2	430.8	390.7	12.3	426.0	417.8	11.4	420.9	446.4	10.6	412.6	474.0	9.8
52.0	452.0	346.1	14.4	448.0	369.4	13.5	443.5	394.7	12.5	438.6	421.5	11.7	433.2	450.1	10.8	423.8	476.0	10.0
55.0	471.7	350.8	14.9	467.3	375.7	13.8	462.8	400.7	12.9	457.8	427.6	12.0	452.3	455.9	11.2	441.0	479.4	10.4

MODEL: YCAV0417S/P												SA_IPLV= 12.5			PA_IPLV= 14.8			
AIR TEMPERATURE ON - CONDENSER (°F)																		
LCWT (°F)	75.0			80.0			85.0			90.0			95.0			100.0		
	TONS	KW	EER	TONS	KW	EER	TONS	KW	EER	TONS	KW	EER	TONS	KW	EER	TONS	KW	EER
40.0	401.1	344.0	12.7	397.9	371.8	11.8	394.4	401.8	10.9	390.6	433.6	10.0	386.5	466.6	9.3	381.7	503.1	8.5
42.0	413.4	346.5	13.1	410.0	373.8	12.1	406.3	403.6	11.2	402.4	435.3	10.3	398.1	468.5	9.5	393.3	505.7	8.8
44.0	425.9	349.2	13.4	422.4	376.3	12.4	418.5	405.8	11.4	414.3	437.2	10.6	409.9	470.5	9.8	404.8	508.0	9.0
45.0	432.3	350.6	13.5	428.6	377.6	12.5	424.7	406.9	11.6	420.4	438.3	10.7	415.9	471.5	9.9	410.6	509.1	9.1
46.0	438.7	352.2	13.6	435.0	378.9	12.7	430.9	408.1	11.7	426.6	439.3	10.8	421.9	472.6	10.0	416.5	510.3	9.2
48.0	451.7	355.6	13.9	447.8	381.8	12.9	443.6	410.6	12.0	439.0	441.8	11.1	434.1	475.0	10.2	428.1	511.8	9.4
50.0	464.9	359.5	14.2	460.9	385.0	13.2	456.5	413.5	12.3	451.7	444.4	11.3	446.6	477.4	10.5	438.9	511.5	9.7
52.0	478.4	363.6	14.5	474.2	388.8	13.5	469.6	416.8	12.5	464.7	447.2	11.6	459.4	480.1	10.7	450.0	511.2	9.9
55.0	499.1	370.5	14.8	494.7	394.9	13.9	489.8	422.2	12.9	484.6	452.0	12.0	478.9	484.5	11.1	467.0	511.0	10.3

**NOTES:**

1. kW = Compressor Input Power
2. EER = Chiller EER (includes power from compressors, fans, and control panels 0.8 kW)
3. LCWT = Leaving Chilled Water Temperature
4. Ratings based on 2.4 GPM cooler water per ton
5. Rated in accordance with ARI Standard 550/590-98 and are accordingly certified



**MODEL: YCAV0357S/P** **SA\_IPLV= 13.5**      **PA\_IPLV= 15.1**

**AIR TEMPERATURE ON - CONDENSER (°F)**

LCWT (°F)	105.0			110.0			115.0			120.0			125.0		
	TONS	KW	EER	TONS	KW	EER	TONS	KW	EER	TONS	KW	EER	TONS	KW	EER
40.0	309.3	432.1	8.1	305.1	453.9	7.6	298.5	473.0	7.2	250.0	399.9	7.0	196.7	315.7	6.9
42.0	317.7	433.0	8.3	313.2	455.0	7.8	303.2	467.1	7.4	251.8	388.7	7.3	199.1	308.3	7.1
44.0	326.3	433.8	8.5	321.6	455.9	8.0	306.9	458.3	7.6	253.8	377.8	7.5	201.5	300.9	7.4
45.0	330.7	434.1	8.6	325.8	456.4	8.1	308.7	453.5	7.7	254.9	372.6	7.7	202.5	297.0	7.5
46.0	335.1	434.5	8.7	330.0	456.9	8.2	310.4	448.4	7.8	256.1	367.7	7.8	203.8	293.6	7.6
48.0	344.0	435.2	8.9	338.8	457.6	8.4	313.6	437.4	8.1	258.5	358.7	8.0	205.9	286.2	7.9
50.0	353.1	435.9	9.2	347.7	458.4	8.6	316.5	425.4	8.4	261.0	349.9	8.3	208.1	279.2	8.2
52.0	362.4	436.7	9.4	356.7	459.1	8.8	319.0	413.0	8.7	263.5	341.2	8.6	210.1	272.3	8.4
55.0	376.6	437.8	9.7	370.6	460.2	9.1	322.4	394.9	9.2	267.1	328.6	9.0	213.1	262.3	8.8

**MODEL: YCAV0397S/P** **SA\_IPLV= 13.2**      **PA\_IPLV= 15.2**

**AIR TEMPERATURE ON - CONDENSER (°F)**

LCWT (°F)	105.0			110.0			115.0			120.0			125.0		
	TONS	KW	EER	TONS	KW	EER	TONS	KW	EER	TONS	KW	EER	TONS	KW	EER
40.0	350.0	486.9	8.1	348.2	518.1	7.6	343.9	546.7	7.2	287.1	458.4	7.1	228.5	366.0	6.9
42.0	359.8	488.8	8.3	357.8	520.2	7.8	348.6	538.4	7.4	290.2	447.7	7.3	231.1	357.3	7.2
44.0	369.8	490.8	8.5	367.6	522.3	8.0	352.2	525.8	7.6	293.2	437.0	7.5	233.7	348.8	7.4
45.0	374.9	491.7	8.6	372.6	523.3	8.1	354.0	519.3	7.7	294.7	431.7	7.7	234.7	344.1	7.5
46.0	380.0	492.6	8.7	377.6	524.5	8.2	355.8	512.8	7.9	296.2	426.4	7.8	236.1	340.2	7.6
48.0	390.5	494.5	8.9	387.8	526.5	8.4	359.5	499.6	8.1	299.2	415.9	8.0	238.3	331.6	7.9
50.0	401.1	496.5	9.1	398.3	528.5	8.6	363.1	486.5	8.4	302.2	405.7	8.3	240.7	323.4	8.2
52.0	411.9	498.5	9.3	409.0	530.5	8.8	366.5	474.1	8.7	305.0	395.6	8.6	243.1	315.4	8.4
55.0	428.7	501.5	9.7	425.3	533.7	9.1	371.3	456.7	9.2	309.1	380.9	9.0	246.5	303.7	8.9

**MODEL: YCAV0417S/P** **SA\_IPLV= 12.5**      **PA\_IPLV= 14.8**

**AIR TEMPERATURE ON - CONDENSER (°F)**

LCWT (°F)	105.0			110.0			115.0			120.0			125.0		
	TONS	KW	EER	TONS	KW	EER	TONS	KW	EER	TONS	KW	EER	TONS	KW	EER
40.0	371.6	528.5	7.9	364.9	550.9	7.5	355.5	569.1	7.1	312.0	512.1	6.9	247.1	407.1	6.7
42.0	381.6	528.7	8.1	374.5	551.7	7.7	364.8	570.5	7.2	315.2	501.7	7.1	249.8	397.2	7.0
44.0	391.7	528.8	8.4	384.4	552.2	7.9	374.3	571.5	7.4	318.6	490.3	7.3	252.8	387.6	7.2
45.0	396.9	528.8	8.5	389.5	552.3	8.0	379.1	571.9	7.5	320.3	484.4	7.4	254.3	382.8	7.3
46.0	402.0	528.7	8.6	394.6	552.3	8.1	384.0	572.1	7.6	322.1	478.4	7.5	255.8	378.1	7.5
48.0	412.3	528.4	8.8	404.6	552.4	8.3	392.0	568.3	7.8	325.7	466.4	7.8	258.7	368.6	7.7
50.0	422.8	528.1	9.0	414.8	552.2	8.5	395.9	554.7	8.1	329.2	454.6	8.1	261.0	358.5	8.0
52.0	433.5	527.7	9.3	425.2	551.9	8.7	400.0	540.6	8.4	332.4	443.7	8.4	263.5	349.2	8.3
55.0	449.7	527.2	9.6	441.1	551.3	9.0	406.3	518.9	8.8	336.9	427.3	8.8	267.3	336.0	8.7

**NOTES:**

1. kW = Compressor Input Power
2. EER = Chiller EER (includes power from compressors, fans, and control panels 0.8 KW)
3. LCWT = Leaving Chilled Water Temperature
4. Ratings based on 2.4 GPM cooler water per ton
5. Rated in accordance with ARI Standard 550/590-98 and are accordingly certified

# Standard Efficiency Ratings - English - 60Hz

MODEL: YCAV0457S/P												SA_IPLV= 12.6			PA_IPLV= 14.7			
AIR TEMPERATURE ON - CONDENSER (°F)																		
LCWT (°F)	75.0			80.0			85.0			90.0			95.0			100.0		
	TONS	KW	EER	TONS	KW	EER	TONS	KW	EER	TONS	KW	EER	TONS	KW	EER	TONS	KW	EER
40.0	429.2	377.0	12.5	425.5	406.0	11.6	421.4	436.7	10.7	416.9	469.3	9.9	412.1	503.3	9.2	406.2	539.9	8.5
42.0	442.4	380.2	12.8	438.5	408.9	11.8	434.3	439.6	11.0	429.7	472.2	10.2	424.7	506.3	9.4	418.3	542.8	8.7
44.0	455.8	383.7	13.1	451.8	412.2	12.1	447.4	442.7	11.2	442.6	475.2	10.4	437.4	509.4	9.6	430.6	545.6	8.9
45.0	462.5	385.5	13.2	458.5	413.9	12.2	454.0	444.3	11.4	449.1	476.8	10.5	443.9	510.9	9.8	436.7	547.0	9.0
46.0	469.4	387.3	13.3	465.3	415.6	12.4	460.7	446.1	11.5	455.7	478.5	10.6	450.4	512.6	9.9	443.0	548.4	9.1
48.0	483.2	391.4	13.6	479.0	419.4	12.6	474.3	449.6	11.7	469.1	481.9	10.9	463.5	516.1	10.1	455.6	551.3	9.3
50.0	497.2	395.7	13.8	492.9	423.4	12.9	488.1	453.4	12.0	482.7	485.6	11.1	476.7	519.1	10.3	468.2	553.9	9.5
52.0	511.5	400.3	14.1	507.1	427.7	13.1	502.1	457.5	12.2	496.6	489.4	11.4	490.1	522.3	10.5	480.5	555.4	9.8
55.0	533.4	407.8	14.4	528.8	434.7	13.5	523.6	464.1	12.6	517.8	495.8	11.7	510.6	527.5	10.9	499.2	557.5	10.1

MODEL: YCAV0477S/P												SA_IPLV= 12.8			PA_IPLV= 14.7			
AIR TEMPERATURE ON - CONDENSER (°F)																		
LCWT (°F)	75.0			80.0			85.0			90.0			95.0			100.0		
	TONS	KW	EER	TONS	KW	EER	TONS	KW	EER	TONS	KW	EER	TONS	KW	EER	TONS	KW	EER
40.0	461.7	396.3	12.8	457.7	426.2	11.9	453.3	458.5	11.0	448.6	492.1	10.2	443.5	527.5	9.4	437.7	567.3	8.7
42.0	476.2	399.8	13.1	472.0	429.7	12.1	467.4	461.7	11.2	462.5	495.5	10.4	457.1	530.9	9.7	451.0	570.9	8.9
44.0	491.0	403.6	13.4	486.7	433.4	12.4	481.9	465.2	11.5	476.6	499.1	10.7	471.0	534.5	9.9	464.5	574.4	9.1
45.0	498.6	405.7	13.5	494.1	435.3	12.6	489.2	467.0	11.6	483.9	500.8	10.8	478.1	536.4	10.0	470.8	575.1	9.2
46.0	506.2	408.0	13.7	501.7	437.3	12.7	496.6	469.0	11.8	491.1	502.8	10.9	485.3	538.3	10.1	477.2	575.8	9.3
48.0	521.7	412.4	13.9	517.0	441.5	13.0	511.7	473.0	12.0	506.0	506.7	11.2	499.8	542.3	10.4	490.1	577.3	9.6
50.0	537.3	417.1	14.2	532.4	446.1	13.2	527.1	477.3	12.3	521.2	510.8	11.4	514.7	546.3	10.6	503.3	578.7	9.8
52.0	553.0	422.3	14.5	548.1	450.8	13.5	542.5	481.9	12.5	536.5	515.1	11.7	530.0	550.6	10.8	516.7	580.2	10.0
55.0	577.7	429.6	14.9	572.0	458.6	13.9	566.2	489.1	12.9	559.8	522.2	12.0	552.9	557.5	11.2	537.0	582.7	10.4

MODEL: YCAV0507S/P												SA_IPLV= 12.5			PA_IPLV= 14.7			
AIR TEMPERATURE ON - CONDENSER (°F)																		
LCWT (°F)	75.0			80.0			85.0			90.0			95.0			100.0		
	TONS	KW	EER	TONS	KW	EER	TONS	KW	EER	TONS	KW	EER	TONS	KW	EER	TONS	KW	EER
40.0	482.0	414.4	12.8	478.0	445.5	11.8	473.5	478.8	11.0	468.6	513.7	10.2	463.4	550.3	9.4	457.4	591.4	8.7
42.0	497.2	418.2	13.1	492.9	449.2	12.1	488.2	482.4	11.2	483.1	517.4	10.4	477.6	553.9	9.7	471.3	595.3	8.9
44.0	512.7	422.2	13.3	508.2	453.2	12.4	503.3	486.1	11.5	497.9	521.1	10.7	492.1	558.0	9.9	485.4	599.2	9.1
45.0	520.5	424.4	13.5	516.0	455.2	12.5	510.9	488.1	11.6	505.4	523.1	10.8	499.5	560.0	10.0	492.2	600.3	9.2
46.0	528.5	426.8	13.6	523.8	457.3	12.7	518.6	490.3	11.8	513.0	525.3	10.9	507.0	562.0	10.1	498.9	601.3	9.4
48.0	544.6	431.5	13.9	539.8	461.8	12.9	534.4	494.5	12.0	528.5	529.5	11.2	522.1	566.4	10.4	512.5	603.4	9.6
50.0	560.7	436.3	14.2	555.8	466.6	13.2	550.4	499.1	12.3	544.3	533.9	11.4	537.7	570.8	10.6	526.5	605.4	9.8
52.0	577.0	441.6	14.4	572.0	471.5	13.5	566.3	504.0	12.5	560.2	538.5	11.6	553.5	575.3	10.8	540.7	607.5	10.0
55.0	602.4	448.6	14.8	596.7	479.6	13.8	590.8	511.5	12.9	584.3	545.9	12.0	577.2	582.5	11.2	562.1	611.0	10.4

**NOTES:**

1. kW = Compressor Input Power
2. EER = Chiller EER (includes power from compressors, fans, and control panels 0.8 KW)
3. LCWT = Leaving Chilled Water Temperature
4. Ratings based on 2.4 GPM cooler water per ton
5. Rated in accordance with ARI Standard 550/590-98 and are accordingly certified

**MODEL: YCAV0457S/P** **SA\_IPLV= 12.6** **PA\_IPLV= 14.7**

## AIR TEMPERATURE ON - CONDENSER (°F)

LCWT (°F)	105.0			110.0			115.0			120.0			125.0		
	TONS	KW	EER	TONS	KW	EER	TONS	KW	EER	TONS	KW	EER	TONS	KW	EER
40.0	396.8	569.8	7.9	392.1	600.7	7.4	352.1	549.2	7.2	287.9	449.9	7.1	227.8	357.2	7.0
42.0	407.8	571.2	8.1	402.7	602.4	7.6	355.3	534.7	7.5	291.5	439.5	7.4	230.3	348.6	7.2
44.0	418.9	572.6	8.3	413.5	604.1	7.8	358.6	520.2	7.7	294.9	429.1	7.6	233.1	340.5	7.4
45.0	424.6	573.2	8.4	419.0	604.8	7.9	360.3	513.2	7.9	296.7	424.0	7.8	234.4	336.4	7.6
46.0	430.3	573.9	8.5	424.6	605.5	8.0	362.1	506.5	8.0	298.4	418.9	7.9	235.8	332.4	7.7
48.0	441.8	575.1	8.7	429.8	591.7	8.2	365.8	493.9	8.3	301.8	408.7	8.2	238.4	324.4	8.0
50.0	453.4	576.2	8.9	434.5	576.5	8.5	369.4	481.8	8.6	305.0	398.8	8.4	240.4	315.7	8.2
52.0	465.3	577.4	9.1	438.8	560.8	8.8	373.0	469.9	8.9	308.2	389.1	8.7	242.7	307.7	8.5
55.0	483.3	579.5	9.4	444.4	537.7	9.3	378.2	452.6	9.3	312.5	374.4	9.2	246.0	296.3	8.9

**MODEL: YCAV0477S/P** **SA\_IPLV= 12.8** **PA\_IPLV= 14.7**

## AIR TEMPERATURE ON - CONDENSER (°F)

LCWT (°F)	105.0			110.0			115.0			120.0			125.0		
	TONS	KW	EER	TONS	KW	EER	TONS	KW	EER	TONS	KW	EER	TONS	KW	EER
40.0	425.7	594.6	8.1	420.9	626.9	7.6	412.9	655.5	7.2	345.6	552.9	7.0	272.9	437.7	6.9
42.0	437.4	596.1	8.3	432.3	628.6	7.8	419.3	647.1	7.4	348.5	538.1	7.3	276.1	427.4	7.1
44.0	449.3	597.6	8.5	443.9	630.3	8.0	424.2	634.0	7.6	351.5	523.6	7.5	279.3	417.2	7.4
45.0	455.4	598.3	8.6	449.7	631.1	8.1	426.6	627.0	7.7	353.1	516.6	7.7	280.7	411.6	7.5
46.0	461.5	598.9	8.7	455.7	631.9	8.2	428.9	619.7	7.8	354.8	510.0	7.8	282.5	407.0	7.6
48.0	474.0	600.2	8.9	467.8	633.4	8.4	433.3	604.2	8.1	358.2	497.4	8.0	285.3	396.7	7.9
50.0	486.6	601.7	9.1	480.2	634.8	8.6	437.4	587.9	8.4	361.7	485.2	8.3	288.3	386.9	8.2
52.0	499.5	603.1	9.4	492.9	636.2	8.8	441.1	571.3	8.7	365.1	473.2	8.6	291.1	377.4	8.4
55.0	519.3	605.2	9.7	512.2	638.4	9.1	446.2	547.4	9.2	370.1	455.6	9.0	295.2	363.5	8.8

**MODEL: YCAV0507S/P** **SA\_IPLV= 12.5** **PA\_IPLV= 14.7**

## AIR TEMPERATURE ON - CONDENSER (°F)

LCWT (°F)	105.0			110.0			115.0			120.0			125.0		
	TONS	KW	EER	TONS	KW	EER	TONS	KW	EER	TONS	KW	EER	TONS	KW	EER
40.0	446.0	621.9	8.1	442.4	658.9	7.6	435.5	692.3	7.2	364.2	582.1	7.0	288.8	462.8	6.9
42.0	458.3	623.9	8.3	454.5	661.2	7.8	442.0	682.8	7.4	367.6	567.6	7.3	292.1	451.9	7.1
44.0	470.9	626.0	8.5	466.8	663.4	8.0	446.8	667.8	7.6	371.2	553.2	7.5	295.4	441.1	7.4
45.0	477.4	627.0	8.6	473.1	664.5	8.1	449.2	659.9	7.7	373.0	546.2	7.7	296.7	435.2	7.5
46.0	483.9	627.9	8.7	479.4	665.7	8.2	451.6	651.9	7.8	374.8	539.3	7.8	298.6	430.2	7.6
48.0	497.1	629.8	8.9	492.3	667.8	8.4	456.2	635.3	8.1	378.6	526.0	8.0	301.5	419.3	7.9
50.0	510.5	631.9	9.1	505.5	669.8	8.6	460.7	618.4	8.4	382.3	513.0	8.3	304.6	409.0	8.2
52.0	524.2	633.9	9.4	518.9	671.8	8.8	464.8	601.8	8.7	385.9	500.3	8.6	307.6	398.9	8.4
55.0	545.2	637.0	9.7	539.5	675.1	9.1	470.6	578.2	9.2	391.1	481.7	9.0	311.9	384.2	8.9

**NOTES:**

1. kW = Compressor Input Power
2. EER = Chiller EER (includes power from compressors, fans, and control panels 0.8 KW)
3. LCWT = Leaving Chilled Water Temperature
4. Ratings based on 2.4 GPM cooler water per ton
5. Rated in accordance with ARI Standard 550/590-98 and are accordingly certified

# Standard Efficiency Ratings - English - 60Hz

MODEL: YCAV0527S/P												SA_IPLV= 11.7			PA_IPLV= 14.7			
AIR TEMPERATURE ON - CONDENSER (°F)																		
LCWT (°F)	75.0			80.0			85.0			90.0			95.0			100.0		
	TONS	KW	EER	TONS	KW	EER	TONS	KW	EER	TONS	KW	EER	TONS	KW	EER	TONS	KW	EER
40.0	502.5	432.5	12.8	498.3	464.7	11.8	493.7	499.1	11.0	488.7	535.1	10.2	483.3	572.9	9.5	477.1	615.4	8.7
42.0	518.2	436.5	13.0	513.9	468.6	12.1	509.0	502.9	11.2	503.7	539.2	10.4	498.1	576.9	9.7	491.6	619.6	8.9
44.0	534.3	440.8	13.3	529.8	472.9	12.4	524.7	507.0	11.5	519.2	543.2	10.7	513.2	581.3	9.9	506.4	624.0	9.1
45.0	542.5	443.0	13.5	537.8	475.1	12.5	532.7	509.1	11.6	527.0	545.3	10.8	520.9	583.4	10.0	513.5	625.4	9.3
46.0	550.8	445.5	13.6	546.0	477.3	12.7	540.7	511.5	11.8	534.9	547.7	10.9	528.7	585.6	10.1	520.6	626.6	9.4
48.0	567.6	450.4	13.9	562.6	482.0	12.9	557.1	516.0	12.0	551.0	552.2	11.2	544.5	590.3	10.4	535.0	629.3	9.6
50.0	584.2	455.4	14.1	579.2	487.0	13.2	573.8	520.8	12.3	567.5	556.9	11.4	560.7	595.0	10.6	549.7	631.9	9.8
52.0	601.0	460.9	14.4	595.9	492.1	13.4	590.2	525.9	12.5	583.9	561.7	11.6	577.1	599.9	10.8	564.7	634.6	10.0
55.0	627.1	467.5	14.8	621.4	500.4	13.8	615.4	533.7	12.9	608.8	569.4	12.0	601.6	607.5	11.1	587.3	639.1	10.4

**NOTES:**

1. kW = Compressor Input Power
2. EER = Chiller EER (includes power from compressors, fans, and control panels 0.8 KW)
3. LCWT = Leaving Chilled Water Temperature
4. Ratings based on 2.4 GPM cooler water per ton
5. Rated in accordance with ARI Standard 550/590-98 and are accordingly certified

MODEL: YCAV0527S/P									SA_IPLV= 11.7			PA_IPLV= 14.7			
AIR TEMPERATURE ON - CONDENSER (°F)															
LCWT (°F)	105.0			110.0			115.0			120.0			125.0		
	TONS	KW	EER	TONS	KW	EER	TONS	KW	EER	TONS	KW	EER	TONS	KW	EER
40.0	466.3	649.1	8.1	463.9	690.7	7.6	458.1	728.8	7.1	382.8	611.3	7.0	304.7	487.8	6.9
42.0	479.3	651.6	8.3	476.7	693.5	7.8	464.8	718.4	7.4	386.9	596.9	7.3	308.2	476.3	7.2
44.0	492.6	654.3	8.5	489.8	696.3	8.0	469.5	701.5	7.6	391.0	582.7	7.5	311.6	464.8	7.4
45.0	499.4	655.5	8.6	496.4	697.7	8.1	471.9	692.8	7.7	393.0	575.6	7.7	312.9	458.7	7.5
46.0	506.3	656.8	8.7	503.1	699.2	8.2	474.3	684.0	7.9	395.0	568.6	7.8	314.8	453.4	7.7
48.0	520.3	659.3	8.9	516.8	701.9	8.4	479.2	666.3	8.1	399.0	554.5	8.0	317.8	441.9	7.9
50.0	534.4	662.0	9.1	530.7	704.6	8.5	484.1	648.9	8.4	402.9	540.8	8.3	321.0	431.1	8.2
52.0	548.9	664.6	9.3	545.0	707.3	8.7	488.7	632.2	8.7	406.7	527.4	8.6	324.1	420.4	8.4
55.0	571.2	668.6	9.7	566.8	711.6	9.0	495.1	609.0	9.1	412.2	507.7	9.0	328.7	404.8	8.9

**NOTES:**

1. kW = Compressor Input Power
2. EER = Chiller EER (includes power from compressors, fans, and control panels 0.8 KW)
3. LCWT = Leaving Chilled Water Temperature
4. Ratings based on 2.4 GPM cooler water per ton
5. Rated in accordance with ARI Standard 550/590-98 and are accordingly certified

# High Efficiency Ratings - English - 60Hz

MODEL: YCAV0157E/V																	E_IPLV= 13.5			V_IPLV= 14.6		
AIR TEMPERATURE ON - CONDENSER (°F)																						
LCWT (°F)	75.0			80.0			85.0			90.0			95.0			100.0						
	TONS	KW	EER	TONS	KW	EER	TONS	KW	EER	TONS	KW	EER	TONS	KW	EER	TONS	KW	EER				
40.0	148.1	121.7	13.1	146.8	130.5	12.2	145.2	139.6	11.4	143.4	149.1	10.6	141.4	158.9	9.8	139.1	170.1	9.1				
42.0	152.7	122.8	13.4	151.5	131.6	12.5	149.9	140.8	11.7	148.1	150.3	10.9	146.1	160.2	10.1	143.7	171.4	9.3				
44.0	157.4	123.9	13.8	156.2	132.8	12.8	154.7	142.0	11.9	152.8	151.6	11.1	150.8	161.6	10.3	148.3	172.8	9.6				
45.0	159.8	124.4	13.9	158.6	133.4	13.0	157.1	142.6	12.1	155.2	152.2	11.2	153.2	162.2	10.5	150.7	173.5	9.7				
46.0	162.2	125.1	14.1	161.0	134.0	13.1	159.5	143.2	12.2	157.7	152.9	11.4	155.6	162.9	10.6	153.0	174.2	9.8				
48.0	167.0	126.2	14.4	165.9	135.2	13.4	164.4	144.6	12.5	162.6	154.2	11.6	160.4	164.3	10.8	157.9	175.6	10.0				
50.0	171.9	127.3	14.7	170.8	136.4	13.7	169.3	145.9	12.8	167.5	155.7	11.9	165.4	165.8	11.1	162.7	177.2	10.2				
52.0	176.8	128.5	15.0	175.8	137.7	14.0	174.4	147.2	13.0	172.6	157.1	12.1	170.4	167.2	11.3	167.7	178.7	10.5				
55.0	184.4	130.2	15.4	183.5	139.6	14.4	182.1	149.2	13.4	180.3	159.2	12.5	178.1	169.5	11.7	174.8	180.6	10.8				

MODEL: YCAV0177E/V																	E_IPLV= 13.5			V_IPLV= 14.7		
AIR TEMPERATURE ON - CONDENSER (°F)																						
LCWT (°F)	75.0			80.0			85.0			90.0			95.0			100.0						
	TONS	KW	EER	TONS	KW	EER	TONS	KW	EER	TONS	KW	EER	TONS	KW	EER	TONS	KW	EER				
40.0	157.1	131.4	13.0	156.3	137.3	12.3	155.0	147.6	11.4	153.5	158.6	10.6	151.9	170.1	9.8	150.0	183.2	9.1				
42.0	162.5	128.7	13.6	161.3	138.3	12.6	159.9	148.5	11.7	158.3	159.4	10.9	156.6	171.0	10.1	154.7	184.1	9.3				
44.0	167.6	129.9	13.9	166.3	139.3	12.9	164.8	149.5	12.0	163.2	160.4	11.2	161.5	171.9	10.4	159.4	185.0	9.6				
45.0	170.2	130.5	14.0	168.9	139.9	13.1	167.4	150.1	12.2	165.7	160.9	11.3	163.9	172.4	10.5	161.8	185.5	9.7				
46.0	172.8	131.2	14.2	171.4	140.5	13.2	169.9	150.6	12.3	168.2	161.4	11.4	166.4	172.9	10.6	164.3	186.0	9.8				
48.0	178.0	132.6	14.5	176.7	141.8	13.5	175.1	151.8	12.6	173.4	162.5	11.7	171.5	174.0	10.9	169.1	186.9	10.0				
50.0	183.4	134.1	14.8	182.0	143.1	13.8	180.4	153.0	12.9	178.6	163.7	12.0	176.6	175.1	11.1	173.9	187.8	10.3				
52.0	188.9	135.7	15.0	187.5	144.6	14.1	185.8	154.4	13.2	183.9	165.0	12.3	181.9	176.3	11.4	178.7	188.7	10.5				
55.0	197.4	138.4	15.4	195.8	147.0	14.5	194.1	156.6	13.6	192.2	167.0	12.7	190.0	178.3	11.8	186.2	190.2	10.9				

MODEL: YCAV0187E/V																	E_IPLV= 13.2			V_IPLV= 15.1		
AIR TEMPERATURE ON - CONDENSER (°F)																						
LCWT (°F)	75.0			80.0			85.0			90.0			95.0			100.0						
	TONS	KW	EER	TONS	KW	EER	TONS	KW	EER	TONS	KW	EER	TONS	KW	EER	TONS	KW	EER				
40.0	174.7	145.0	13.1	173.7	152.7	12.3	172.2	164.6	11.4	170.5	177.2	10.5	168.7	190.5	9.8	166.5	205.3	9.0				
42.0	180.2	146.1	13.4	179.2	153.6	12.6	177.7	165.4	11.7	175.9	178.0	10.8	174.0	191.3	10.0	171.7	206.3	9.2				
44.0	185.8	147.5	13.7	184.8	154.7	12.9	183.2	166.4	12.0	181.4	178.9	11.1	179.4	192.1	10.3	177.0	207.2	9.5				
45.0	189.0	144.5	14.1	187.6	155.3	13.1	186.0	166.9	12.2	184.2	179.4	11.3	182.1	192.6	10.4	179.7	207.7	9.6				
46.0	191.8	145.2	14.2	190.4	155.8	13.2	188.8	167.4	12.3	187.0	179.9	11.4	184.9	193.1	10.6	182.5	208.1	9.7				
48.0	197.5	146.7	14.5	196.2	157.1	13.5	194.5	168.6	12.6	192.6	180.9	11.7	190.5	194.1	10.8	188.0	209.1	10.0				
50.0	203.4	148.3	14.8	202.0	158.6	13.8	200.3	169.8	12.9	198.4	182.1	12.0	196.2	195.2	11.1	193.3	209.5	10.2				
52.0	209.3	150.0	15.1	207.9	160.1	14.1	206.2	171.3	13.2	204.2	183.4	12.2	202.0	196.4	11.4	198.6	210.0	10.5				
55.0	218.4	153.0	15.4	217.0	162.7	14.5	215.3	173.6	13.6	213.2	185.5	12.6	210.9	198.4	11.8	206.8	210.7	10.9				

**NOTES:**

1. kW = Compressor Input Power
2. EER = Chiller EER (includes power from compressors, fans, and control panels 0.8 KW)
3. LCWT = Leaving Chilled Water Temperature
4. Ratings based on 2.4 GPM cooler water per ton
5. Rated in accordance with ARI Standard 550/590-98
6. Certified in accordance with the ARI Water-Chilling Packages Using the Vapor Compression Cycle Certification Program, which is based on ARI Standard 550/590.

MODEL: YCAV0157E/V										E_IPLV= 13.5			V_IPLV= 14.6		
AIR TEMPERATURE ON - CONDENSER (°F)															
LCWT (°F)	105.0			110.0			115.0			120.0			125.0		
	TONS	KW	EER	TONS	KW	EER	TONS	KW	EER	TONS	KW	EER	TONS	KW	EER
40.0	136.1	181.5	8.4	133.0	193.9	7.7	128.7	205.9	7.0	118.0	203.6	6.5	91.8	160.1	6.4
42.0	140.1	182.5	8.6	136.8	194.8	7.9	132.5	206.8	7.2	119.4	199.0	6.7	93.0	156.4	6.6
44.0	144.2	183.5	8.8	140.7	195.9	8.1	136.3	207.6	7.4	120.8	194.5	7.0	94.2	152.7	6.8
45.0	146.3	184.0	8.9	142.7	196.3	8.2	138.2	208.1	7.5	121.5	192.2	7.1	94.8	150.9	6.9
46.0	148.3	184.5	9.0	144.7	196.9	8.3	140.0	208.7	7.6	122.2	190.0	7.2	95.3	149.1	7.0
48.0	152.5	185.5	9.2	148.8	197.9	8.5	143.9	209.7	7.7	123.6	185.6	7.4	96.5	145.5	7.3
50.0	156.7	186.5	9.4	152.9	198.9	8.6	148.0	210.7	7.9	124.9	181.3	7.7	97.6	141.9	7.5
52.0	161.0	187.6	9.6	157.1	200.0	8.8	152.0	211.8	8.1	126.1	176.9	7.9	98.7	138.5	7.8
55.0	167.5	189.3	9.9	163.5	201.6	9.1	155.4	206.3	8.5	128.0	170.8	8.3	100.2	133.6	8.2

MODEL: YCAV0177E/V										E_IPLV= 13.5			V_IPLV= 14.7		
AIR TEMPERATURE ON - CONDENSER (°F)															
LCWT (°F)	105.0			110.0			115.0			120.0			125.0		
	TONS	KW	EER	TONS	KW	EER	TONS	KW	EER	TONS	KW	EER	TONS	KW	EER
40.0	147.0	195.7	8.4	145.4	210.9	7.7	141.4	224.3	7.1	121.3	198.4	6.8	94.1	156.3	6.6
42.0	151.2	196.5	8.6	149.4	211.5	7.9	145.2	225.1	7.3	122.7	194.1	7.0	95.3	153.1	6.8
44.0	155.6	197.2	8.8	153.4	212.2	8.1	149.1	225.8	7.4	124.2	189.7	7.3	96.4	149.5	7.0
45.0	157.8	197.6	8.9	155.5	212.5	8.2	151.1	226.1	7.5	124.9	187.5	7.4	97.0	147.8	7.1
46.0	160.0	198.0	9.0	157.5	212.8	8.3	152.3	224.5	7.6	125.6	185.4	7.5	97.6	146.0	7.3
48.0	164.6	198.7	9.2	161.7	213.4	8.5	154.1	219.1	7.9	127.0	181.2	7.8	98.8	142.5	7.5
50.0	169.2	199.6	9.5	166.0	214.1	8.7	155.9	213.7	8.2	128.3	177.0	8.0	99.9	139.1	7.8
52.0	173.9	200.5	9.7	170.3	214.7	8.9	157.7	208.3	8.5	129.5	172.7	8.3	101.0	135.7	8.0
55.0	180.8	201.5	10.0	177.0	215.8	9.2	160.2	200.6	8.9	131.4	166.8	8.7	102.5	131.0	8.4

MODEL: YCAV0187E/V										E_IPLV= 13.2			V_IPLV= 15.1		
AIR TEMPERATURE ON - CONDENSER (°F)															
LCWT (°F)	105.0			110.0			115.0			120.0			125.0		
	TONS	KW	EER	TONS	KW	EER	TONS	KW	EER	TONS	KW	EER	TONS	KW	EER
40.0	163.0	217.8	8.3	161.5	231.1	7.8	157.2	241.8	7.3	138.0	220.3	7.0	109.3	177.3	6.8
42.0	167.8	218.3	8.6	166.0	231.5	8.0	161.5	242.4	7.5	139.8	216.0	7.2	110.6	173.1	7.0
44.0	172.7	218.7	8.8	170.6	231.9	8.2	165.9	242.9	7.7	141.6	211.6	7.4	112.0	168.9	7.2
45.0	175.2	218.8	8.9	172.9	232.1	8.3	168.1	243.2	7.8	142.6	209.3	7.6	112.6	166.8	7.4
46.0	177.7	219.0	9.0	175.3	232.2	8.4	170.4	243.4	7.9	143.5	206.9	7.7	113.3	164.7	7.5
48.0	182.8	219.4	9.3	180.0	232.5	8.7	175.0	243.7	8.1	145.2	202.2	8.0	114.3	160.1	7.8
50.0	188.0	219.7	9.5	184.8	232.7	8.9	176.8	237.5	8.3	146.7	197.4	8.2	115.4	156.0	8.0
52.0	193.2	220.1	9.8	189.8	232.9	9.1	178.8	231.6	8.6	147.9	192.4	8.5	116.5	152.0	8.3
55.0	201.2	220.7	10.2	197.3	233.2	9.5	181.7	223.0	9.1	149.9	185.4	8.9	118.2	146.5	8.7

**NOTES:**

1. kW = Compressor Input Power
2. EER = Chiller EER (includes power from compressors, fans, and control panels 0.8 KW)
3. LCWT = Leaving Chilled Water Temperature
4. Ratings based on 2.4 GPM cooler water per ton
5. Rated in accordance with ARI Standard 550/590-98
6. Certified in accordance with the ARI Water-Chilling Packages Using the Vapor Compression Cycle Certification Program, which is based on ARI Standard 550/590.

# High Efficiency Ratings - English - 60Hz

MODEL: YCAV0197E/V																	E_IPLV= 12.9			V_IPLV= 15.0		
AIR TEMPERATURE ON - CONDENSER (°F)																						
LCWT (°F)	75.0			80.0			85.0			90.0			95.0			100.0						
	TONS	KW	EER	TONS	KW	EER	TONS	KW	EER	TONS	KW	EER	TONS	KW	EER	TONS	KW	EER				
40.0	189.8	153.1	13.4	188.2	165.6	12.4	186.4	179.5	11.4	184.5	194.4	10.5	182.5	210.2	9.6	180.1	227.8	8.8				
42.0	195.8	154.3	13.7	194.1	166.4	12.7	192.2	180.0	11.7	190.3	194.8	10.8	188.1	210.6	9.9	185.6	228.4	9.1				
44.0	201.9	155.8	14.0	200.1	167.5	13.0	198.2	180.8	12.0	196.1	195.4	11.1	193.9	211.0	10.2	191.3	228.9	9.3				
45.0	205.0	156.6	14.2	203.2	168.2	13.2	201.3	181.3	12.2	199.1	195.7	11.2	196.8	211.2	10.4	194.2	229.1	9.5				
46.0	208.1	157.6	14.3	206.3	168.8	13.3	204.3	181.8	12.3	202.2	196.0	11.4	199.8	211.5	10.5	197.1	229.4	9.6				
48.0	214.5	159.6	14.6	212.6	170.4	13.6	210.6	182.9	12.7	208.3	196.9	11.7	205.8	212.2	10.8	203.0	230.0	9.9				
50.0	221.0	162.1	14.8	219.1	172.3	13.9	216.9	184.3	12.9	214.5	198.1	12.0	212.0	213.1	11.1	209.0	230.9	10.1				
52.0	227.7	164.8	15.0	225.7	174.5	14.2	223.4	186.1	13.2	221.0	199.4	12.3	218.3	214.2	11.3	215.2	231.7	10.4				
55.0	237.9	169.6	15.3	235.8	178.3	14.5	233.4	189.1	13.6	230.8	201.8	12.7	228.0	216.1	11.7	223.7	231.3	10.8				

MODEL: YCAV0207E/V																	E_IPLV= 13.4			V_IPLV= 15.0		
AIR TEMPERATURE ON - CONDENSER (°F)																						
LCWT (°F)	75.0			80.0			85.0			90.0			95.0			100.0						
	TONS	KW	EER	TONS	KW	EER	TONS	KW	EER	TONS	KW	EER	TONS	KW	EER	TONS	KW	EER				
40.0	201.7	161.2	13.5	200.1	173.9	12.5	198.3	187.9	11.5	196.4	203.1	10.6	194.4	219.0	9.8	192.0	237.1	9.0				
42.0	208.1	162.5	13.8	206.4	175.0	12.8	204.5	188.7	11.8	202.5	203.7	10.9	200.4	219.6	10.1	197.9	237.7	9.3				
44.0	214.6	164.1	14.1	212.8	176.2	13.1	210.9	189.7	12.2	208.8	204.4	11.2	206.5	220.3	10.4	203.9	238.4	9.5				
45.0	217.9	165.0	14.3	216.1	176.9	13.3	214.1	190.2	12.3	211.9	204.8	11.4	209.6	220.6	10.5	206.9	238.8	9.7				
46.0	221.3	165.9	14.4	219.4	177.6	13.4	217.4	190.8	12.5	215.1	205.4	11.5	212.8	221.1	10.7	210.0	239.2	9.8				
48.0	228.1	168.1	14.7	226.1	179.3	13.7	224.0	192.2	12.8	221.7	206.5	11.8	219.2	222.0	10.9	216.2	239.8	10.0				
50.0	235.0	170.4	14.9	233.0	181.3	14.0	230.8	193.8	13.0	228.4	207.7	12.1	225.8	223.0	11.2	222.3	240.0	10.3				
52.0	242.1	173.1	15.2	240.0	183.4	14.3	237.7	195.6	13.3	235.2	209.2	12.4	232.5	224.3	11.5	228.5	240.3	10.6				
55.0	252.7	177.6	15.5	250.6	187.2	14.6	248.2	198.7	13.7	245.6	211.9	12.8	242.7	226.5	11.9	238.0	241.0	11.0				

MODEL: YCAV0227E/V																	E_IPLV= 13.1			V_IPLV= 15.0		
AIR TEMPERATURE ON - CONDENSER (°F)																						
LCWT (°F)	75.0			80.0			85.0			90.0			95.0			100.0						
	TONS	KW	EER	TONS	KW	EER	TONS	KW	EER	TONS	KW	EER	TONS	KW	EER	TONS	KW	EER				
40.0	209.5	167.1	13.4	207.9	179.8	12.5	206.1	193.4	11.6	204.2	208.1	10.7	202.1	223.5	10.0	199.8	241.0	9.2				
42.0	216.1	168.5	13.7	214.5	181.0	12.8	212.6	194.6	11.9	210.6	209.1	11.0	208.4	224.5	10.2	205.9	242.0	9.4				
44.0	222.9	170.1	14.1	221.2	182.3	13.1	219.2	195.8	12.2	217.1	210.2	11.3	214.9	225.6	10.5	212.2	243.1	9.7				
45.0	226.4	171.0	14.2	224.6	183.1	13.3	222.6	196.4	12.3	220.4	210.8	11.5	218.1	226.1	10.6	215.4	243.7	9.8				
46.0	229.8	171.9	14.4	228.0	183.9	13.4	226.0	197.1	12.5	223.8	211.4	11.6	221.4	226.8	10.8	218.6	244.2	9.9				
48.0	236.9	173.9	14.7	235.0	185.6	13.7	232.9	198.7	12.8	230.6	212.8	11.9	228.1	228.0	11.0	225.2	245.5	10.2				
50.0	244.0	176.0	14.9	242.1	187.5	14.0	239.9	200.3	13.1	237.6	214.2	12.2	235.0	229.3	11.3	232.0	246.8	10.4				
52.0	251.1	178.3	15.2	249.2	189.5	14.3	247.0	202.1	13.3	244.6	215.9	12.4	242.0	230.8	11.6	238.9	248.2	10.7				
55.0	262.1	182.1	15.6	260.1	192.9	14.6	257.8	205.1	13.7	255.3	218.6	12.8	252.5	233.3	12.0	249.2	250.5	11.0				

**NOTES:**

1. kW = Compressor Input Power
2. EER = Chiller EER (includes power from compressors, fans, and control panels 0.8 KW)
3. LCWT = Leaving Chilled Water Temperature
4. Ratings based on 2.4 GPM cooler water per ton
5. Rated in accordance with ARI Standard 550/590-98
6. Certified in accordance with the ARI Water-Chilling Packages Using the Vapor Compression Cycle Certification Program, which is based on ARI Standard 550/590.



MODEL: YCAV0197E/V										E_IPLV= 12.9			V_IPLV= 15.0		
AIR TEMPERATURE ON - CONDENSER (°F)															
LCWT (°F)	105.0			110.0			115.0			120.0			125.0		
	TONS	KW	EER	TONS	KW	EER	TONS	KW	EER	TONS	KW	EER	TONS	KW	EER
40.0	176.4	243.2	8.1	173.2	254.5	7.7	168.6	263.6	7.2	154.1	252.2	6.9	122.0	200.2	6.7
42.0	181.3	242.8	8.4	177.8	254.5	7.9	173.1	263.9	7.4	155.8	246.6	7.1	123.5	195.4	7.0
44.0	186.2	242.3	8.6	182.6	254.2	8.1	177.7	264.0	7.6	157.5	240.7	7.3	124.9	190.6	7.2
45.0	188.7	242.1	8.7	185.1	254.0	8.2	180.1	264.0	7.7	158.4	237.7	7.5	125.7	188.2	7.4
46.0	191.2	241.8	8.9	187.5	253.8	8.3	182.4	264.0	7.8	159.3	234.7	7.6	126.4	185.9	7.5
48.0	196.4	241.2	9.1	192.5	253.4	8.6	187.2	263.7	8.0	161.0	228.8	7.9	127.5	180.8	7.7
50.0	201.6	240.6	9.4	197.5	252.9	8.8	192.1	263.3	8.2	162.6	223.2	8.1	128.8	176.1	8.0
52.0	206.9	240.1	9.7	202.7	252.3	9.0	197.1	262.8	8.5	164.0	217.6	8.4	130.0	171.6	8.3
55.0	214.9	239.4	10.1	210.6	251.4	9.4	200.9	253.7	8.9	166.3	209.7	8.8	132.0	165.4	8.7

MODEL: YCAV0207E/V										E_IPLV= 13.4			V_IPLV= 15.0		
AIR TEMPERATURE ON - CONDENSER (°F)															
LCWT (°F)	105.0			110.0			115.0			120.0			125.0		
	TONS	KW	EER	TONS	KW	EER	TONS	KW	EER	TONS	KW	EER	TONS	KW	EER
40.0	188.3	252.6	8.3	186.0	266.5	7.8	181.3	276.3	7.4	159.1	249.7	7.1	125.7	198.5	7.0
42.0	193.7	252.8	8.6	191.0	266.5	8.0	186.1	276.6	7.6	160.9	244.0	7.4	127.2	193.8	7.2
44.0	199.2	253.0	8.8	196.1	266.4	8.3	191.1	276.7	7.8	162.7	238.2	7.6	128.7	189.1	7.4
45.0	202.0	253.0	8.9	198.7	266.2	8.4	193.6	276.7	7.9	163.7	235.2	7.7	129.5	186.7	7.6
46.0	204.8	253.1	9.1	201.4	266.1	8.5	196.1	276.6	8.0	164.6	232.3	7.9	130.2	184.4	7.7
48.0	210.6	253.2	9.3	206.7	265.7	8.7	200.4	274.7	8.2	166.4	226.5	8.1	131.4	179.3	8.0
50.0	216.2	252.8	9.6	212.1	265.3	9.0	202.5	267.6	8.5	168.1	221.1	8.4	132.7	174.7	8.2
52.0	221.8	252.4	9.8	217.6	264.9	9.2	204.6	260.4	8.8	169.6	215.6	8.7	133.6	170.2	8.5
55.0	230.5	251.9	10.2	226.1	264.2	9.6	207.9	249.8	9.3	171.9	207.8	9.1	136.0	164.1	8.9

MODEL: YCAV0227E/V										E_IPLV= 13.1			V_IPLV= 15.0		
AIR TEMPERATURE ON - CONDENSER (°F)															
LCWT (°F)	105.0			110.0			115.0			120.0			125.0		
	TONS	KW	EER	TONS	KW	EER	TONS	KW	EER	TONS	KW	EER	TONS	KW	EER
40.0	197.2	259.1	8.5	195.1	273.8	8.0	190.3	284.0	7.5	182.5	290.6	7.0	151.1	244.3	6.9
42.0	203.2	260.3	8.7	200.4	273.9	8.2	195.4	284.3	7.7	187.4	291.0	7.2	152.7	238.7	7.1
44.0	209.4	261.4	8.9	205.9	273.9	8.4	200.7	284.4	7.9	192.3	291.4	7.4	154.3	232.6	7.3
45.0	212.4	261.7	9.0	208.6	274.0	8.5	203.3	284.5	8.0	194.3	290.2	7.5	155.1	229.7	7.5
46.0	215.2	261.7	9.2	211.4	273.9	8.6	206.0	284.6	8.1	195.2	286.9	7.6	156.1	227.0	7.6
48.0	221.0	261.7	9.4	217.0	273.9	8.9	211.4	284.6	8.3	197.1	280.2	7.9	157.5	221.4	7.8
50.0	226.9	261.7	9.7	222.8	273.9	9.1	217.0	284.5	8.5	199.1	273.1	8.1	159.1	216.1	8.1
52.0	232.9	261.7	9.9	228.6	273.8	9.3	222.7	284.4	8.8	201.1	265.9	8.4	160.6	210.8	8.3
55.0	242.1	261.8	10.3	237.6	273.7	9.7	231.3	284.3	9.1	204.2	254.9	8.9	162.9	203.1	8.8

**NOTES:**

1. kW = Compressor Input Power
2. EER = Chiller EER (includes power from compressors, fans, and control panels 0.8 KW)
3. LCWT = Leaving Chilled Water Temperature
4. Ratings based on 2.4 GPM cooler water per ton
5. Rated in accordance with ARI Standard 550/590-98
6. Certified in accordance with the ARI Water-Chilling Packages Using the Vapor Compression Cycle Certification Program, which is based on ARI Standard 550/590.

# High Efficiency Ratings - English - 60Hz

MODEL: YCAV0247E/V															E_IPLV= 12.8			V_IPLV= 14.9		
AIR TEMPERATURE ON - CONDENSER (°F)																				
LCWT (°F)	75.0			80.0			85.0			90.0			95.0			100.0				
	TONS	KW	EER	TONS	KW	EER	TONS	KW	EER	TONS	KW	EER	TONS	KW	EER	TONS	KW	EER		
40.0	232.7	192.6	13.1	230.8	206.9	12.2	228.7	222.3	11.3	226.4	238.6	10.5	223.9	255.8	9.7	221.1	275.2	9.0		
42.0	240.0	194.4	13.4	238.0	208.6	12.5	235.8	223.9	11.6	233.4	240.2	10.8	230.8	257.3	10.0	227.9	276.8	9.2		
44.0	247.4	196.3	13.7	245.4	210.4	12.8	243.1	225.6	11.9	240.6	241.8	11.0	237.9	259.0	10.2	234.7	278.3	9.4		
45.0	251.2	197.4	13.9	249.1	211.4	12.9	246.8	226.5	12.0	244.2	242.7	11.1	241.4	259.9	10.3	238.1	278.9	9.6		
46.0	255.1	198.5	14.0	252.9	212.3	13.1	250.5	227.4	12.1	247.9	243.6	11.3	245.1	260.7	10.5	241.5	279.6	9.7		
48.0	262.8	200.8	14.3	260.6	214.5	13.3	258.1	229.4	12.4	255.4	245.4	11.5	252.4	262.6	10.7	248.4	280.9	9.9		
50.0	270.8	203.3	14.5	268.5	216.8	13.6	265.9	231.5	12.7	263.1	247.5	11.8	260.0	264.5	11.0	255.5	282.2	10.1		
52.0	278.9	205.9	14.8	276.5	219.2	13.9	273.8	233.8	12.9	270.9	249.6	12.0	267.7	266.6	11.2	262.8	283.6	10.4		
55.0	291.2	209.7	15.2	288.7	223.1	14.2	285.9	237.5	13.3	282.8	253.1	12.4	279.5	269.8	11.6	273.9	286.0	10.7		

MODEL: YCAV0267E/V															E_IPLV= 13.3			V_IPLV= 14.9		
AIR TEMPERATURE ON - CONDENSER (°F)																				
LCWT (°F)	75.0			80.0			85.0			90.0			95.0			100.0				
	TONS	KW	EER	TONS	KW	EER	TONS	KW	EER	TONS	KW	EER	TONS	KW	EER	TONS	KW	EER		
40.0	264.2	211.7	13.5	261.9	228.6	12.5	259.3	246.9	11.5	256.4	266.4	10.6	253.3	286.8	9.8	249.7	309.7	9.0		
42.0	272.6	213.3	13.8	270.3	229.9	12.8	267.6	248.0	11.8	264.6	267.4	10.9	261.3	287.9	10.1	257.6	310.9	9.2		
44.0	281.2	215.2	14.1	278.8	231.4	13.1	276.0	249.2	12.1	272.9	268.5	11.2	269.5	288.9	10.4	265.6	312.2	9.5		
45.0	285.5	216.3	14.3	283.1	232.3	13.3	280.3	249.9	12.3	277.2	269.1	11.4	273.7	289.5	10.5	269.7	312.7	9.6		
46.0	289.9	217.4	14.4	287.4	233.2	13.4	284.6	250.7	12.5	281.4	269.8	11.5	277.9	290.1	10.6	273.8	313.4	9.8		
48.0	298.8	219.9	14.7	296.3	235.3	13.7	293.4	252.4	12.8	290.1	271.2	11.8	286.5	291.4	10.9	282.2	314.7	10.0		
50.0	307.8	222.7	15.0	305.3	237.6	14.0	302.3	254.4	13.1	299.0	273.0	12.1	295.2	293.0	11.2	290.8	316.1	10.3		
52.0	317.0	225.8	15.3	314.5	240.3	14.3	311.5	256.6	13.3	308.0	274.9	12.4	304.2	294.7	11.5	299.6	317.8	10.5		
55.0	331.1	231.1	15.6	328.5	244.8	14.7	325.4	260.5	13.8	321.9	278.2	12.8	317.9	297.6	11.9	312.4	319.0	10.9		

MODEL: YCAV0287E/V															E_IPLV= 12.9			V_IPLV= 14.8		
AIR TEMPERATURE ON - CONDENSER (°F)																				
LCWT (°F)	75.0			80.0			85.0			90.0			95.0			100.0				
	TONS	KW	EER	TONS	KW	EER	TONS	KW	EER	TONS	KW	EER	TONS	KW	EER	TONS	KW	EER		
40.0	281.2	222.4	13.6	278.8	240.6	12.6	276.1	260.6	11.6	273.1	282.2	10.7	270.0	304.7	9.8	266.3	330.2	9.0		
42.0	290.1	224.2	14.0	287.6	241.7	12.9	284.8	261.4	11.9	281.7	282.7	11.0	278.4	305.4	10.1	274.6	331.0	9.3		
44.0	299.3	226.2	14.3	296.7	243.2	13.3	293.8	262.4	12.3	290.5	283.5	11.3	287.1	306.0	10.4	283.1	331.8	9.5		
45.0	303.9	227.4	14.4	301.3	244.2	13.4	298.3	263.1	12.4	295.0	284.0	11.5	291.5	306.4	10.5	287.4	332.2	9.6		
46.0	308.6	228.7	14.6	305.9	245.2	13.6	302.9	263.9	12.6	299.6	284.5	11.6	296.0	306.8	10.7	291.8	332.6	9.8		
48.0	318.1	231.7	14.9	315.4	247.4	13.9	312.2	265.5	12.9	308.8	285.7	11.9	305.0	307.8	11.0	300.7	333.6	10.1		
50.0	327.8	235.1	15.1	325.0	250.0	14.2	321.8	267.5	13.2	318.2	287.4	12.2	314.3	309.2	11.3	309.8	334.6	10.3		
52.0	337.8	239.0	15.3	334.8	253.2	14.4	331.5	269.9	13.5	327.8	289.4	12.5	323.8	310.7	11.6	319.1	335.8	10.6		
55.0	353.0	245.8	15.6	349.9	258.6	14.8	346.5	274.4	13.9	342.7	292.8	12.9	338.4	313.4	12.0	333.2	337.9	11.0		

**NOTES:**

1. kW = Compressor Input Power
2. EER = Chiller EER (includes power from compressors, fans, and control panels 0.8 KW)
3. LCWT = Leaving Chilled Water Temperature
4. Ratings based on 2.4 GPM cooler water per ton
5. Rated in accordance with ARI Standard 550/590-98 and are accordingly certified

MODEL: YCAV0247E/V										E_IPLV= 12.8			V_IPLV= 14.9		
AIR TEMPERATURE ON - CONDENSER (°F)															
LCWT (°F)	105.0			110.0			115.0			120.0			125.0		
	TONS	KW	EER	TONS	KW	EER	TONS	KW	EER	TONS	KW	EER	TONS	KW	EER
40.0	216.9	292.5	8.3	215.0	310.1	7.8	210.7	324.2	7.3	175.1	271.2	7.2	138.0	215.5	7.0
42.0	223.2	293.8	8.5	220.9	310.8	8.0	213.1	317.5	7.6	176.6	263.9	7.5	139.7	210.4	7.3
44.0	229.7	294.9	8.7	227.0	311.6	8.2	215.6	310.6	7.8	178.2	256.9	7.7	141.2	205.1	7.5
45.0	232.8	295.2	8.9	230.0	311.9	8.3	216.7	306.9	8.0	179.1	253.6	7.9	142.1	202.8	7.6
46.0	236.0	295.5	9.0	233.1	312.3	8.4	217.9	303.0	8.1	179.9	250.4	8.0	142.7	200.1	7.8
48.0	242.4	296.1	9.2	239.4	312.9	8.6	220.1	295.0	8.4	181.7	244.3	8.2	144.3	195.3	8.0
50.0	248.9	296.8	9.4	245.8	313.6	8.8	222.1	286.7	8.7	183.4	238.3	8.5	145.8	190.5	8.3
52.0	255.5	297.5	9.7	252.3	314.2	9.1	223.9	278.6	9.0	185.1	232.4	8.8	147.2	185.8	8.6
55.0	265.7	298.6	10.0	262.3	315.3	9.4	226.5	267.6	9.4	187.6	223.8	9.2	149.2	178.9	9.0

MODEL: YCAV0267E/V										E_IPLV= 13.3			V_IPLV= 14.9		
AIR TEMPERATURE ON - CONDENSER (°F)															
LCWT (°F)	105.0			110.0			115.0			120.0			125.0		
	TONS	KW	EER	TONS	KW	EER	TONS	KW	EER	TONS	KW	EER	TONS	KW	EER
40.0	244.9	331.1	8.3	240.0	348.3	7.7	233.3	363.0	7.2	214.8	354.1	6.8	169.7	283.0	6.6
42.0	251.8	331.4	8.5	246.7	348.8	8.0	239.6	363.8	7.4	217.3	347.1	7.0	171.8	276.6	6.9
44.0	258.9	331.4	8.8	253.5	349.1	8.2	246.1	364.5	7.6	219.9	339.8	7.3	174.0	270.2	7.1
45.0	262.4	331.4	8.9	256.8	349.3	8.3	249.4	364.7	7.7	221.3	336.1	7.4	175.1	266.9	7.2
46.0	266.0	331.5	9.0	260.3	349.3	8.4	252.8	364.9	7.8	222.6	332.3	7.5	176.1	263.7	7.4
48.0	273.3	331.4	9.2	267.4	349.4	8.6	259.6	365.3	8.0	225.2	324.6	7.8	178.2	257.4	7.6
50.0	280.7	331.3	9.5	274.6	349.5	8.8	266.5	365.5	8.2	227.7	316.8	8.0	179.7	250.2	7.9
52.0	288.2	331.3	9.7	281.9	349.5	9.1	273.6	365.6	8.4	229.9	309.3	8.3	181.7	244.1	8.1
55.0	299.8	331.4	10.1	293.2	349.4	9.4	281.3	358.8	8.8	232.9	297.9	8.7	184.3	234.9	8.6

MODEL: YCAV0287E/V										E_IPLV= 12.9			V_IPLV= 14.8		
AIR TEMPERATURE ON - CONDENSER (°F)															
LCWT (°F)	105.0			110.0			115.0			120.0			125.0		
	TONS	KW	EER	TONS	KW	EER	TONS	KW	EER	TONS	KW	EER	TONS	KW	EER
40.0	261.8	354.9	8.3	256.9	371.2	7.8	250.1	384.5	7.3	234.7	381.9	6.9	185.5	304.0	6.8
42.0	269.1	354.4	8.5	263.9	371.2	8.0	256.8	385.1	7.5	237.1	374.0	7.1	187.7	296.9	7.0
44.0	276.5	353.7	8.8	271.1	371.0	8.2	263.6	385.3	7.7	239.6	365.4	7.4	189.9	289.7	7.2
45.0	280.3	353.4	8.9	274.7	370.8	8.3	267.1	385.3	7.8	240.9	361.0	7.5	191.0	286.2	7.4
46.0	284.1	353.0	9.0	278.4	370.5	8.4	270.7	385.2	7.9	242.3	356.5	7.6	192.1	282.6	7.5
48.0	291.8	352.3	9.3	285.9	369.9	8.7	277.9	385.0	8.1	244.9	347.6	7.9	194.3	275.6	7.8
50.0	299.7	351.5	9.5	293.6	369.2	8.9	285.2	384.5	8.4	247.5	339.0	8.2	195.7	267.6	8.0
52.0	307.7	350.8	9.8	301.3	368.5	9.2	292.8	383.9	8.6	249.8	331.0	8.4	0.0	0.0	0.0
55.0	320.0	349.8	10.2	313.3	367.3	9.6	304.4	382.8	9.0	253.1	318.8	8.8	200.7	251.3	8.7

**NOTES:**

1. kW = Compressor Input Power
2. EER = Chiller EER (includes power from compressors, fans, and control panels 0.8 KW)
3. LCWT = Leaving Chilled Water Temperature
4. Ratings based on 2.4 GPM cooler water per ton
5. Rated in accordance with ARI Standard 550/590-98 and are accordingly certified

# High Efficiency Ratings - English - 60Hz

MODEL: YCAV0327E/V																	E_IPLV= 13.8			V_IPLV= 14.8		
AIR TEMPERATURE ON - CONDENSER (°F)																						
LCWT (°F)	75.0			80.0			85.0			90.0			95.0			100.0						
	TONS	KW	EER	TONS	KW	EER	TONS	KW	EER	TONS	KW	EER	TONS	KW	EER	TONS	KW	EER				
40.0	305.7	244.9	13.5	303.0	264.3	12.5	300.2	285.6	11.5	297.2	308.6	10.6	293.9	332.8	9.8	290.2	360.1	9.0				
42.0	315.4	246.9	13.8	312.6	265.9	12.8	309.7	286.8	11.8	306.4	309.5	10.9	303.0	333.8	10.1	299.1	361.2	9.2				
44.0	325.4	249.3	14.1	322.5	267.8	13.1	319.3	288.4	12.2	315.9	310.7	11.2	312.3	334.8	10.4	308.2	362.3	9.5				
45.0	330.4	250.7	14.3	327.5	268.8	13.3	324.3	289.2	12.3	320.8	311.4	11.4	317.1	335.4	10.5	312.8	362.9	9.6				
46.0	335.5	252.1	14.4	332.5	270.0	13.4	329.2	290.1	12.5	325.7	312.3	11.5	321.9	336.1	10.6	317.5	363.6	9.8				
48.0	345.9	255.3	14.7	342.8	272.5	13.7	339.4	292.2	12.8	335.6	313.9	11.8	331.6	337.6	10.9	326.7	364.4	10.0				
50.0	356.6	258.9	15.0	353.3	275.5	14.0	349.7	294.7	13.1	345.8	315.9	12.1	341.7	339.2	11.2	335.8	364.4	10.3				
52.0	367.5	262.9	15.2	364.0	278.9	14.3	360.3	297.4	13.3	356.2	318.2	12.4	351.9	341.2	11.5	345.0	364.6	10.6				
55.0	384.2	270.0	15.5	380.5	284.7	14.7	376.6	302.2	13.7	372.3	322.4	12.8	367.7	344.7	11.9	359.2	365.2	11.0				

MODEL: YCAV0357E/V																	E_IPLV= 12.2			V_IPLV= 15.3		
AIR TEMPERATURE ON - CONDENSER (°F)																						
LCWT (°F)	75.0			80.0			85.0			90.0			95.0			100.0						
	TONS	KW	EER	TONS	KW	EER	TONS	KW	EER	TONS	KW	EER	TONS	KW	EER	TONS	KW	EER				
40.0	346.6	284.0	13.2	343.6	304.5	12.3	340.1	326.6	11.4	336.3	349.9	10.6	332.2	374.5	9.9	327.5	402.4	9.1				
42.0	357.6	286.7	13.5	354.5	307.2	12.6	351.0	329.1	11.7	347.0	352.4	10.9	342.7	376.9	10.1	337.8	404.9	9.3				
44.0	368.9	289.8	13.8	365.6	310.1	12.9	362.0	331.8	12.0	357.9	355.0	11.1	353.5	379.5	10.4	348.3	407.5	9.5				
45.0	374.5	291.4	14.0	371.3	311.6	13.0	367.6	333.3	12.1	363.5	356.4	11.3	358.9	380.9	10.5	353.7	408.8	9.7				
46.0	380.3	293.1	14.1	377.0	313.1	13.2	373.3	334.8	12.3	369.0	358.0	11.4	364.4	382.4	10.6	359.1	410.3	9.8				
48.0	391.9	296.6	14.4	388.6	316.4	13.5	384.7	337.9	12.5	380.4	361.0	11.7	375.7	385.3	10.8	369.9	412.9	10.0				
50.0	403.8	300.3	14.7	400.4	320.0	13.7	396.5	341.3	12.8	392.0	364.1	11.9	387.1	388.4	11.1	380.7	415.0	10.3				
52.0	415.9	304.4	14.9	412.4	323.7	14.0	408.4	344.9	13.1	403.8	367.5	12.2	398.8	391.7	11.3	391.6	417.1	10.5				
55.0	434.4	309.8	15.3	431.1	328.9	14.4	426.7	350.6	13.4	422.0	373.0	12.6	416.7	397.1	11.7	408.3	420.6	10.9				

MODEL: YCAV0397E/V																	E_IPLV= 12.7			V_IPLV= 15.0		
AIR TEMPERATURE ON - CONDENSER (°F)																						
LCWT (°F)	75.0			80.0			85.0			90.0			95.0			100.0						
	TONS	KW	EER	TONS	KW	EER	TONS	KW	EER	TONS	KW	EER	TONS	KW	EER	TONS	KW	EER				
40.0	369.8	295.7	13.5	366.7	320.2	12.4	363.3	347.1	11.4	359.6	375.8	10.5	355.6	406.0	9.7	351.0	439.9	8.9				
42.0	381.6	297.7	13.8	378.4	321.6	12.8	374.9	348.1	11.8	370.9	376.6	10.9	366.8	406.7	10.0	361.9	440.9	9.2				
44.0	393.7	300.4	14.1	390.4	323.4	13.1	386.7	349.3	12.1	382.5	377.5	11.2	378.2	407.7	10.3	373.1	441.9	9.4				
45.0	399.7	301.8	14.3	396.4	324.6	13.3	392.7	350.1	12.3	388.5	378.1	11.3	384.0	408.1	10.4	378.8	442.6	9.5				
46.0	405.6	303.4	14.4	402.3	325.7	13.4	398.7	350.9	12.4	394.5	378.8	11.5	389.9	408.7	10.6	384.5	443.1	9.7				
48.0	417.7	306.8	14.7	414.4	328.3	13.7	410.6	353.0	12.7	406.4	380.2	11.8	401.7	409.9	10.9	396.3	444.3	10.0				
50.0	430.0	310.9	15.0	426.6	331.4	14.0	422.7	355.3	13.0	418.4	382.0	12.1	413.6	411.3	11.2	408.0	445.5	10.2				
52.0	442.6	315.6	15.2	439.1	335.0	14.3	435.0	358.1	13.3	430.5	384.5	12.4	425.6	413.2	11.4	419.8	447.0	10.5				
55.0	461.8	323.6	15.5	458.0	341.6	14.6	453.9	363.3	13.7	449.2	388.5	12.8	444.1	416.4	11.8	438.0	449.9	10.9				

**NOTES:**

1. kW = Compressor Input Power
2. EER = Chiller EER (includes power from compressors, fans, and control panels 0.8 KW)
3. LCWT = Leaving Chilled Water Temperature
4. Ratings based on 2.4 GPM cooler water per ton
5. Rated in accordance with ARI Standard 550/590-98 and are accordingly certified

**MODEL: YCAV0327E/V** **E\_IPLV= 13.8** **V\_IPLV= 14.8****AIR TEMPERATURE ON - CONDENSER (°F)**

LCWT (°F)	105.0			110.0			115.0			120.0			125.0		
	TONS	KW	EER	TONS	KW	EER	TONS	KW	EER	TONS	KW	EER	TONS	KW	EER
40.0	283.6	382.0	8.3	279.5	401.6	7.8	272.1	416.0	7.4	238.7	376.7	7.1	188.4	300.1	6.9
42.0	291.6	382.1	8.6	286.9	401.7	8.0	279.4	416.5	7.6	241.3	368.4	7.3	190.6	293.1	7.2
44.0	299.7	382.2	8.8	294.6	401.5	8.3	286.7	416.8	7.8	244.0	359.7	7.6	192.9	286.0	7.4
45.0	303.9	382.1	8.9	298.5	401.3	8.4	290.4	416.8	7.9	245.4	355.3	7.7	194.0	282.5	7.5
46.0	308.1	382.2	9.0	302.4	401.1	8.5	294.2	416.8	8.0	246.8	350.9	7.8	195.2	278.9	7.7
48.0	316.6	382.0	9.3	310.4	400.7	8.7	300.8	414.3	8.2	249.4	342.2	8.1	197.2	271.7	7.9
50.0	325.0	381.4	9.6	318.5	400.1	9.0	303.9	403.8	8.5	252.0	333.9	8.4	198.8	264.1	8.2
52.0	333.5	380.8	9.8	326.8	399.5	9.2	307.0	393.1	8.8	254.1	325.7	8.7	200.9	257.6	8.5
55.0	346.6	380.1	10.2	339.6	398.5	9.6	311.8	377.3	9.3	257.7	313.9	9.1	203.9	248.3	8.9

**MODEL: YCAV0357E/V** **E\_IPLV= 12.2** **V\_IPLV= 15.3****AIR TEMPERATURE ON - CONDENSER (°F)**

LCWT (°F)	105.0			110.0			115.0			120.0			125.0		
	TONS	KW	EER	TONS	KW	EER	TONS	KW	EER	TONS	KW	EER	TONS	KW	EER
40.0	321.2	428.4	8.4	318.9	456.0	7.9	313.2	479.3	7.4	271.6	426.9	7.1	214.7	339.4	7.0
42.0	330.8	430.1	8.6	328.0	457.4	8.1	321.9	480.8	7.6	274.1	416.0	7.4	217.2	331.4	7.2
44.0	340.5	431.9	8.8	337.3	458.6	8.3	330.9	482.2	7.7	276.7	405.3	7.6	219.7	323.5	7.5
45.0	345.5	432.8	9.0	342.0	459.3	8.4	335.5	482.9	7.8	278.1	400.1	7.8	220.7	319.3	7.6
46.0	350.5	433.7	9.1	346.8	459.9	8.5	337.3	477.0	8.0	279.4	395.1	7.9	222.1	315.7	7.7
48.0	360.8	435.5	9.3	356.5	461.3	8.7	340.8	464.8	8.3	282.2	385.4	8.1	224.3	307.7	8.0
50.0	370.9	436.8	9.5	366.4	462.6	8.9	344.1	452.2	8.6	284.9	375.9	8.4	226.6	300.2	8.2
52.0	381.1	438.3	9.8	376.5	464.0	9.1	347.1	439.9	8.9	287.6	366.7	8.7	228.8	292.7	8.5
55.0	396.9	440.6	10.1	392.0	466.2	9.5	351.3	422.7	9.3	291.4	353.1	9.1	232.1	281.9	8.9

**MODEL: YCAV0397E/V** **E\_IPLV= 12.7** **V\_IPLV= 15.0****AIR TEMPERATURE ON - CONDENSER (°F)**

LCWT (°F)	105.0			110.0			115.0			120.0			125.0		
	TONS	KW	EER	TONS	KW	EER	TONS	KW	EER	TONS	KW	EER	TONS	KW	EER
40.0	345.6	473.3	8.2	339.3	494.9	7.7	330.5	512.3	7.3	312.0	512.1	6.9	247.1	407.1	6.7
42.0	355.2	472.8	8.4	348.6	495.0	7.9	339.4	513.2	7.4	315.2	501.7	7.1	249.8	397.2	7.0
44.0	365.1	472.0	8.7	358.0	494.8	8.1	348.5	513.7	7.6	318.6	490.3	7.3	252.8	387.6	7.2
45.0	370.1	471.5	8.8	362.9	494.6	8.2	353.1	513.7	7.7	320.3	484.4	7.4	254.3	382.8	7.3
46.0	375.2	471.0	8.9	367.8	494.3	8.4	357.8	513.7	7.8	322.1	478.4	7.5	255.8	378.1	7.5
48.0	385.3	470.1	9.2	377.8	493.5	8.6	367.3	513.4	8.1	325.7	466.4	7.8	258.7	368.6	7.7
50.0	395.8	469.0	9.4	387.9	492.6	8.8	377.1	512.9	8.3	329.2	454.6	8.1	261.0	358.5	8.0
52.0	406.3	468.1	9.7	398.2	491.7	9.1	387.1	512.1	8.5	332.4	443.7	8.4	263.5	349.2	8.3
55.0	422.1	466.7	10.1	413.8	490.1	9.5	402.5	510.7	8.9	336.9	427.3	8.8	267.3	336.0	8.7

**NOTES:**

1. kW = Compressor Input Power
2. EER = Chiller EER (includes power from compressors, fans, and control panels 0.8 KW)
3. LCWT = Leaving Chilled Water Temperature
4. Ratings based on 2.4 GPM cooler water per ton
5. Rated in accordance with ARI Standard 550/590-98 and are accordingly certified

# High Efficiency Ratings - English - 60Hz

MODEL: YCAV0417E/V																	E_IPLV= 13.3			V_IPLV= 14.9		
AIR TEMPERATURE ON - CONDENSER (°F)																						
LCWT (°F)	75.0			80.0			85.0			90.0			95.0			100.0						
	TONS	KW	EER	TONS	KW	EER	TONS	KW	EER	TONS	KW	EER	TONS	KW	EER	TONS	KW	EER				
40.0	408.0	322.7	13.6	404.6	348.1	12.6	400.8	376.0	11.6	396.8	406.2	10.7	392.6	438.1	9.9	387.7	474.2	9.1				
42.0	421.0	325.4	13.9	417.4	350.2	12.9	413.5	377.6	12.0	409.3	407.4	11.1	404.7	439.3	10.2	399.6	475.5	9.4				
44.0	434.3	328.7	14.3	430.5	352.7	13.3	426.4	379.7	12.3	422.0	409.0	11.4	417.3	440.6	10.5	411.8	477.0	9.6				
45.0	441.1	330.5	14.4	437.2	354.1	13.4	433.0	380.8	12.4	428.5	409.9	11.5	423.6	441.4	10.6	418.0	477.7	9.7				
46.0	447.9	332.4	14.6	444.0	355.7	13.6	439.7	382.0	12.6	435.0	411.0	11.7	430.1	442.3	10.8	424.3	478.5	9.9				
48.0	461.8	336.8	14.8	457.7	359.2	13.9	453.3	384.7	12.9	448.4	413.2	12.0	443.2	444.2	11.1	436.8	479.6	10.1				
50.0	476.0	341.7	15.1	471.8	363.2	14.1	467.1	388.1	13.2	462.0	415.8	12.2	456.6	446.4	11.3	449.2	480.1	10.4				
52.0	490.6	347.2	15.3	486.1	367.7	14.4	481.2	391.8	13.5	476.0	418.9	12.5	470.3	448.9	11.6	461.9	480.7	10.7				
55.0	512.9	356.8	15.6	508.2	375.5	14.8	503.0	398.2	13.9	497.4	424.4	12.9	491.4	453.6	12.0	481.3	482.2	11.1				

MODEL: YCAV0477E/V																	E_IPLV= 13.2			V_IPLV= 14.9		
AIR TEMPERATURE ON - CONDENSER (°F)																						
LCWT (°F)	75.0			80.0			85.0			90.0			95.0			100.0						
	TONS	KW	EER	TONS	KW	EER	TONS	KW	EER	TONS	KW	EER	TONS	KW	EER	TONS	KW	EER				
40.0	448.7	361.7	13.4	444.8	388.3	12.5	440.5	416.9	11.6	435.8	447.4	10.7	430.7	479.7	9.9	424.8	516.3	9.2				
42.0	463.0	365.2	13.7	459.0	391.4	12.8	454.6	419.8	11.9	449.6	450.2	11.0	444.3	482.4	10.2	438.1	519.1	9.4				
44.0	477.6	369.1	14.0	473.5	395.0	13.1	468.9	423.0	12.1	463.8	453.2	11.3	458.2	485.3	10.5	451.7	522.0	9.6				
45.0	485.0	371.2	14.1	480.8	396.9	13.2	476.1	424.8	12.3	470.9	454.9	11.4	465.3	486.8	10.6	458.6	523.5	9.8				
46.0	492.4	373.4	14.3	488.3	398.8	13.3	483.5	426.6	12.4	478.2	456.6	11.5	472.4	488.5	10.7	465.7	525.1	9.9				
48.0	507.6	378.0	14.6	503.3	403.0	13.6	498.4	430.4	12.7	492.9	460.1	11.8	486.9	491.8	11.0	479.8	528.1	10.1				
50.0	523.1	383.1	14.8	518.7	407.6	13.9	513.6	434.6	13.0	508.0	463.9	12.1	501.8	495.4	11.2	493.9	530.6	10.4				
52.0	538.6	388.6	15.1	534.2	412.5	14.2	529.2	439.1	13.2	523.4	468.2	12.4	517.0	499.4	11.5	508.2	533.2	10.6				
55.0	562.4	396.4	15.5	0.0	0.0	0.0	552.6	446.5	13.6	546.7	474.9	12.7	540.2	505.8	11.9	530.3	537.6	11.0				

**NOTES:**

1. kW = Compressor Input Power
2. EER = Chiller EER (includes power from compressors, fans, and control panels 0.8 KW)
3. LCWT = Leaving Chilled Water Temperature
4. Ratings based on 2.4 GPM cooler water per ton
5. Rated in accordance with ARI Standard 550/590-98 and are accordingly certified

MODEL: YCAV0417E/V										E_IPLV= 13.3			V_IPLV= 14.9		
AIR TEMPERATURE ON - CONDENSER (°F)															
LCWT (°F)	105.0			110.0			115.0			120.0			125.0		
	TONS	KW	EER	TONS	KW	EER	TONS	KW	EER	TONS	KW	EER	TONS	KW	EER
40.0	379.8	505.2	8.4	375.1	533.1	7.9	365.4	552.5	7.4	320.5	500.5	7.2	252.7	398.9	7.0
42.0	390.8	505.6	8.6	385.2	533.0	8.1	375.1	553.1	7.6	324.0	489.3	7.4	255.8	389.5	7.2
44.0	402.0	506.0	8.9	395.6	532.7	8.3	385.0	553.3	7.8	327.7	477.7	7.6	258.8	380.1	7.4
45.0	407.7	506.1	9.0	400.8	532.4	8.4	390.1	553.3	7.9	329.6	471.9	7.8	260.3	375.4	7.6
46.0	413.5	506.3	9.1	406.1	532.1	8.6	395.2	553.2	8.0	331.4	466.1	7.9	261.9	370.8	7.7
48.0	425.1	506.4	9.4	416.9	531.4	8.8	404.1	549.8	8.3	335.0	454.5	8.2	264.5	361.1	8.0
50.0	436.5	505.5	9.7	427.9	530.6	9.0	408.3	535.7	8.6	338.4	443.6	8.5	266.7	351.1	8.2
52.0	448.0	504.7	9.9	439.2	529.7	9.3	412.5	521.4	8.9	341.3	432.7	8.7	269.5	342.4	8.5
55.0	465.7	503.8	10.3	456.4	528.4	9.7	419.0	500.3	9.4	346.0	417.1	9.1	273.5	330.0	8.9

MODEL: YCAV0477E/V										E_IPLV= 13.2			V_IPLV= 14.9		
AIR TEMPERATURE ON - CONDENSER (°F)															
LCWT (°F)	105.0			110.0			115.0			120.0			125.0		
	TONS	KW	EER	TONS	KW	EER	TONS	KW	EER	TONS	KW	EER	TONS	KW	EER
40.0	417.2	551.6	8.5	414.4	587.4	7.9	406.3	615.8	7.4	351.9	548.0	7.2	277.1	434.4	7.0
42.0	429.8	553.5	8.7	426.1	588.7	8.1	417.6	617.3	7.6	354.9	533.2	7.4	280.5	424.2	7.2
44.0	442.6	555.6	8.9	438.1	589.8	8.3	429.1	618.7	7.8	358.1	518.9	7.7	283.8	414.1	7.5
45.0	449.1	556.6	9.0	444.2	590.3	8.5	435.0	619.4	7.9	359.8	512.1	7.8	285.1	408.7	7.6
46.0	455.7	557.7	9.1	450.4	590.8	8.6	437.5	612.2	8.0	361.5	505.6	7.9	287.0	404.1	7.7
48.0	469.1	559.8	9.4	462.9	592.0	8.8	442.0	596.5	8.3	365.1	493.2	8.2	289.9	393.9	8.0
50.0	482.2	560.9	9.6	475.6	593.0	9.0	446.3	580.0	8.6	368.6	481.1	8.5	292.9	384.3	8.3
52.0	495.4	562.1	9.9	488.7	594.1	9.2	450.1	563.6	8.9	372.0	469.2	8.8	295.8	374.8	8.5
55.0	515.7	564.2	10.2	508.6	596.0	9.6	455.3	540.8	9.4	377.0	451.8	9.2	299.9	361.0	9.0

**NOTES:**

1. kW = Compressor Input Power
2. EER = Chiller EER (includes power from compressors, fans, and control panels 0.8 KW)
3. LCWT = Leaving Chilled Water Temperature
4. Ratings based on 2.4 GPM cooler water per ton
5. Rated in accordance with ARI Standard 550/590-98 and are accordingly certified

# Standard Efficiency Ratings - SI - 60Hz

## MODEL: YCAV0157S/P

### AIR TEMPERATURE ON - CONDENSER (°C)

LCWT (°C)	25.0			30.0			35.0			40.0			45.0			50.0		
	KW	KW	COP	KW	KW	COP	KW	KW	COP	KW	KW	COP	KW	KW	COP	KW	KW	COP
5.0	528.8	135.9	3.5	520.9	155.3	3.1	511.8	176.4	2.7	497.4	200.1	2.3	478.0	225.1	2.0	375.1	189.3	1.9
6.0	543.2	136.7	3.6	535.0	156.1	3.2	525.5	177.2	2.8	509.5	200.8	2.4	489.2	225.8	2.0	378.9	185.3	1.9
7.0	557.9	137.6	3.7	549.4	156.9	3.2	539.5	178.1	2.8	521.7	201.4	2.4	500.4	226.8	2.1	383.1	181.6	2.0
8.0	572.9	138.6	3.8	564.1	157.8	3.3	553.7	179.0	2.9	533.9	202.0	2.5	512.1	227.5	2.1	387.2	177.9	2.0
9.0	588.0	139.6	3.8	578.9	158.7	3.4	568.2	179.9	2.9	546.3	202.6	2.5	524.0	228.2	2.2	391.2	174.2	2.1
10.0	603.4	140.8	3.9	594.1	159.7	3.4	583.0	180.9	3.0	558.9	203.2	2.6	535.8	228.9	2.2	395.2	170.6	2.2
11.0	619.1	141.9	4.0	609.5	160.8	3.5	598.0	182.0	3.1	571.6	203.8	2.6	547.9	229.6	2.3	399.2	167.0	2.2
12.0	635.0	143.2	4.1	625.1	161.9	3.6	613.2	183.1	3.1	584.5	204.4	2.7	560.1	230.2	2.3	403.0	163.5	2.3
13.0	651.2	144.5	4.1	641.0	163.1	3.6	628.7	184.2	3.2	597.5	205.1	2.7	572.5	230.9	2.3	406.8	160.0	2.3

## MODEL: YCAV0177S/P

### AIR TEMPERATURE ON - CONDENSER (°C)

LCWT (°C)	25.0			30.0			35.0			40.0			45.0			50.0		
	KW	KW	COP	KW	KW	COP	KW	KW	COP	KW	KW	COP	KW	KW	COP	KW	KW	COP
5.0	587.3	149.5	3.6	576.4	171.3	3.1	563.2	194.8	2.7	536.0	213.2	2.4	496.0	220.3	2.1	346.9	156.8	2.0
6.0	603.7	150.6	3.7	592.6	172.3	3.2	579.1	195.9	2.8	550.1	213.8	2.4	501.5	216.2	2.2	350.7	153.4	2.1
7.0	620.4	151.6	3.8	609.2	173.3	3.3	595.2	197.0	2.8	563.9	214.3	2.5	507.6	212.3	2.3	354.5	150.1	2.2
8.0	637.4	152.7	3.8	626.0	174.4	3.3	611.2	197.8	2.9	577.7	214.6	2.5	514.0	208.4	2.3	358.1	146.9	2.2
9.0	654.7	153.9	3.9	643.0	175.5	3.4	626.8	198.3	3.0	591.8	215.0	2.6	519.6	204.2	2.4	361.7	143.7	2.3
10.0	672.0	155.1	4.0	660.4	176.6	3.5	642.6	198.8	3.0	605.9	215.4	2.7	524.9	199.9	2.5	365.1	140.6	2.4
11.0	689.4	156.6	4.1	677.8	177.9	3.5	658.6	199.3	3.1	620.3	215.7	2.7	529.6	195.6	2.5	368.4	137.5	2.4
12.0	707.1	158.1	4.1	695.4	179.2	3.6	674.7	199.8	3.2	634.8	216.0	2.8	534.0	191.4	2.6	371.7	134.5	2.5
13.0	725.1	159.6	4.2	713.3	180.6	3.7	691.0	200.4	3.2	649.5	216.3	2.8	538.1	187.3	2.7	374.7	131.6	2.6

## MODEL: YCAV0187S/P

### AIR TEMPERATURE ON - CONDENSER (°C)

LCWT (°C)	25.0			30.0			35.0			40.0			45.0			50.0		
	KW	KW	COP	KW	KW	COP	KW	KW	COP	KW	KW	COP	KW	KW	COP	KW	KW	COP
5.0	639.4	161.3	3.6	628.8	184.3	3.2	616.7	209.4	2.8	594.6	234.7	2.4	570.9	257.1	2.1	438.5	206.9	2.0
6.0	657.2	162.5	3.7	646.3	185.3	3.2	633.7	210.4	2.8	608.9	235.1	2.4	584.4	257.7	2.1	442.7	202.4	2.0
7.0	675.3	163.7	3.8	664.0	186.4	3.3	651.0	211.6	2.9	623.5	235.5	2.5	598.1	258.2	2.2	447.1	198.1	2.1
8.0	693.7	165.1	3.9	682.0	187.6	3.4	668.4	212.8	2.9	638.4	235.8	2.5	612.0	258.7	2.2	451.3	193.8	2.2
9.0	712.5	166.6	3.9	700.4	188.9	3.4	686.2	214.0	3.0	653.5	236.2	2.6	626.2	259.1	2.3	455.6	189.6	2.2
10.0	731.6	168.1	4.0	719.0	190.3	3.5	704.3	215.3	3.1	668.7	236.6	2.7	640.6	259.5	2.3	459.7	185.3	2.3
11.0	751.0	169.7	4.1	738.0	191.7	3.6	722.8	216.7	3.1	683.9	237.0	2.7	653.4	258.4	2.4	463.8	181.2	2.4
12.0	770.7	171.5	4.1	757.3	193.3	3.6	741.6	218.1	3.2	699.5	237.4	2.8	658.8	251.8	2.5	467.9	177.2	2.4
13.0	790.7	173.4	4.2	776.9	194.9	3.7	760.7	219.7	3.2	715.3	237.8	2.8	664.8	245.5	2.6	471.9	173.1	2.5

### NOTES:

1. kW<sub>o</sub> = Unit kW Cooling Capacity Output
2. kW<sub>i</sub> = Compressor kW Input
3. COP = Coefficient of Performance (includes condenser fan power)
4. LCWT = Leaving Chilled Water Temperature
5. Ratings based on 0.15 L/s cooler water per ton, and 0.018 (m<sup>2</sup> - °C)/kW



**MODEL: YCAV0207S/P****AIR TEMPERATURE ON - CONDENSER (°C)**

LCWT (°C)	25.0			30.0			35.0			40.0			45.0			50.0		
	KW	KW	COP	KW	KW	COP	KW	KW	COP	KW	KW	COP	KW	KW	COP	KW	KW	COP
5.0	689.5	174.1	3.6	676.6	200.8	3.1	662.1	230.6	2.7	629.2	253.3	2.3	569.3	248.9	2.2	396.8	175.6	2.1
6.0	709.0	175.2	3.7	695.5	201.6	3.2	680.0	231.2	2.8	644.2	253.1	2.4	574.7	243.5	2.2	402.2	174.8	2.1
7.0	728.8	176.5	3.8	714.8	202.5	3.3	697.4	231.3	2.8	659.6	252.8	2.5	581.3	238.6	2.3	405.5	168.1	2.2
8.0	749.1	178.0	3.9	734.4	203.5	3.4	715.2	231.5	2.9	675.3	252.5	2.5	587.4	233.3	2.4	409.7	164.5	2.3
9.0	769.7	179.7	4.0	754.5	204.7	3.4	733.3	231.7	3.0	691.2	252.1	2.6	593.4	228.2	2.4	413.8	161.0	2.4
10.0	790.7	181.7	4.0	774.9	206.1	3.5	751.7	232.0	3.0	707.2	251.7	2.7	599.0	223.2	2.5	417.7	157.5	2.4
11.0	812.1	183.9	4.1	795.7	207.7	3.6	770.3	232.4	3.1	723.6	251.3	2.7	604.1	218.5	2.6	421.5	154.1	2.5
12.0	834.0	186.3	4.1	816.9	209.4	3.6	789.3	232.9	3.2	740.2	250.9	2.8	609.1	213.8	2.7	425.3	150.8	2.6
13.0	856.2	188.9	4.2	838.5	211.4	3.7	808.6	233.6	3.3	757.1	250.6	2.9	614.0	209.2	2.7	428.8	147.5	2.6

**MODEL: YCAV0227S/P****AIR TEMPERATURE ON - CONDENSER (°C)**

LCWT (°C)	25.0			30.0			35.0			40.0			45.0			50.0		
	KW	KW	COP	KW	KW	COP	KW	KW	COP	KW	KW	COP	KW	KW	COP	KW	KW	COP
5.0	748.4	186.3	3.7	735.1	212.7	3.2	720.1	241.8	2.8	690.4	268.3	2.4	663.0	287.9	2.2	505.5	228.6	2.1
6.0	769.6	187.7	3.8	755.7	214.0	3.3	739.9	243.0	2.9	707.1	268.5	2.5	678.6	288.3	2.2	509.9	223.6	2.1
7.0	791.1	189.3	3.8	776.7	215.3	3.4	760.1	244.5	2.9	724.0	268.6	2.5	694.5	288.5	2.3	514.9	219.0	2.2
8.0	813.1	191.0	3.9	798.1	216.8	3.4	780.9	245.9	3.0	741.2	268.7	2.6	710.7	288.7	2.3	519.8	214.3	2.3
9.0	835.5	192.8	4.0	819.9	218.4	3.5	802.0	247.4	3.0	758.8	268.7	2.7	727.1	288.9	2.4	524.7	209.6	2.3
10.0	858.4	194.8	4.1	842.2	220.1	3.6	823.6	248.9	3.1	776.3	268.8	2.7	743.9	288.9	2.4	529.5	205.0	2.4
11.0	881.7	196.9	4.1	864.9	221.9	3.6	845.6	250.6	3.2	794.4	268.9	2.8	751.4	283.0	2.5	534.3	200.5	2.5
12.0	905.3	199.2	4.2	888.1	223.9	3.7	867.9	252.5	3.2	812.7	269.0	2.8	758.2	276.3	2.6	539.0	196.0	2.5
13.0	929.1	201.6	4.3	911.5	225.9	3.8	890.8	254.3	3.3	831.3	269.1	2.9	765.1	269.4	2.7	543.6	191.5	2.6

**MODEL: YCAV0247S/P****AIR TEMPERATURE ON - CONDENSER (°C)**

LCWT (°C)	25.0			30.0			35.0			40.0			45.0			50.0		
	KW	KW	COP	KW	KW	COP	KW	KW	COP	KW	KW	COP	KW	KW	COP	KW	KW	COP
5.0	821.2	205.3	3.7	807.2	233.7	3.2	791.2	265.0	2.8	762.5	295.6	2.4	742.6	323.7	2.2	553.3	248.0	2.1
6.0	844.2	206.9	3.8	829.7	235.2	3.3	812.9	266.5	2.9	781.4	296.3	2.5	760.5	324.5	2.2	558.8	242.7	2.1
7.0	867.7	208.7	3.8	852.5	236.9	3.3	834.9	268.3	2.9	800.6	296.9	2.5	778.7	325.3	2.3	564.1	237.5	2.2
8.0	891.5	210.6	3.9	875.8	238.6	3.4	857.5	270.0	3.0	820.1	297.5	2.6	797.2	326.1	2.3	569.5	232.2	2.3
9.0	915.8	212.6	4.0	899.5	240.5	3.5	880.5	271.8	3.0	839.9	298.1	2.7	805.0	319.3	2.4	574.8	227.1	2.3
10.0	940.5	214.7	4.0	923.7	242.4	3.5	904.0	273.6	3.1	859.8	298.7	2.7	812.7	312.2	2.5	579.9	222.0	2.4
11.0	965.7	217.0	4.1	948.2	244.5	3.6	927.8	275.6	3.2	880.3	299.3	2.8	820.1	304.6	2.5	585.1	217.1	2.5
12.0	991.2	219.5	4.2	973.3	246.7	3.7	952.1	277.6	3.2	901.1	300.0	2.8	826.9	296.9	2.6	590.4	212.3	2.6
13.0	1017.2	221.4	4.2	998.6	248.9	3.7	976.9	279.8	3.3	922.2	300.7	2.9	833.1	289.1	2.7	595.3	207.5	2.6

**NOTES:**

1. kW<sub>o</sub> = Unit kW Cooling Capacity Output
2. kW<sub>i</sub> = Compressor kW Input
3. COP = Coefficient of Performance (includes condenser fan power)
4. LCWT = Leaving Chilled Water Temperature
5. Ratings based on 0.15 L/s cooler water per ton, and 0.018 (m<sup>2</sup> - °C)/kW

# Standard Efficiency Ratings - SI - 60Hz

## MODEL: YCAV0267S/P

### AIR TEMPERATURE ON - CONDENSER (°C)

LCWT (°C)	25.0			30.0			35.0			40.0			45.0			50.0		
	KW	KW	COP	KW	KW	COP	KW	KW	COP	KW	KW	COP	KW	KW	COP	KW	KW	COP
5.0	894.3	224.1	3.7	879.6	254.5	3.2	862.6	287.9	2.8	834.9	322.6	2.4	822.5	359.0	2.2	617.9	276.6	2.1
6.0	919.1	225.9	3.7	903.8	256.3	3.3	886.1	289.8	2.9	856.0	323.7	2.5	842.6	360.4	2.2	623.9	270.6	2.2
7.0	944.5	227.9	3.8	928.6	258.2	3.3	909.9	291.8	2.9	877.4	324.8	2.5	863.1	361.7	2.3	629.9	264.7	2.2
8.0	970.2	230.0	3.9	953.7	260.2	3.4	934.4	293.8	3.0	899.1	325.9	2.6	884.1	363.0	2.3	635.8	258.9	2.3
9.0	996.3	232.2	4.0	979.4	262.3	3.5	959.2	295.9	3.0	921.3	327.0	2.7	892.1	354.8	2.4	641.5	253.1	2.4
10.0	1023.0	234.5	4.0	1005.4	264.4	3.5	984.6	298.0	3.1	943.6	328.3	2.7	900.3	346.3	2.5	647.2	247.5	2.4
11.0	1050.0	236.9	4.1	1031.8	266.8	3.6	1010.4	300.2	3.2	966.5	329.4	2.8	908.4	337.8	2.5	652.8	242.0	2.5
12.0	1077.5	239.6	4.2	1058.8	269.2	3.7	1036.6	302.5	3.2	989.7	330.6	2.8	916.3	329.6	2.6	658.4	236.6	2.6
13.0	1105.6	241.0	4.2	1086.0	271.7	3.7	1063.2	305.0	3.3	1013.3	331.9	2.9	923.9	321.6	2.7	663.5	231.2	2.6

## MODEL: YCAV0287S/P

### AIR TEMPERATURE ON - CONDENSER (°C)

LCWT (°C)	25.0			30.0			35.0			40.0			45.0			50.0		
	KW	KW	COP	KW	KW	COP	KW	KW	COP	KW	KW	COP	KW	KW	COP	KW	KW	COP
5.0	949.5	235.7	3.7	932.1	270.9	3.2	911.8	309.3	2.8	873.5	343.0	2.4	798.6	346.4	2.2	557.0	246.8	2.1
6.0	976.3	237.2	3.8	958.3	272.2	3.3	937.2	310.6	2.8	895.5	343.5	2.5	807.5	340.1	2.2	563.2	241.6	2.1
7.0	1003.6	238.8	3.9	985.0	273.5	3.3	962.8	311.8	2.9	917.2	343.8	2.5	816.1	333.3	2.3	569.4	236.4	2.2
8.0	1031.4	240.6	3.9	1012.3	275.0	3.4	988.1	312.5	3.0	939.4	343.9	2.6	826.2	327.1	2.4	575.4	231.4	2.3
9.0	1059.7	242.7	4.0	1040.1	276.6	3.5	1013.9	313.3	3.0	962.0	344.1	2.6	835.4	320.5	2.4	581.2	226.4	2.3
10.0	1088.5	244.9	4.1	1068.4	278.3	3.6	1040.2	314.2	3.1	985.0	344.1	2.7	844.1	313.9	2.5	586.9	221.6	2.4
11.0	1117.8	247.5	4.2	1097.2	280.3	3.6	1066.9	315.2	3.2	1008.2	344.2	2.8	852.1	307.3	2.6	592.3	216.8	2.5
12.0	1147.6	250.2	4.2	1126.5	282.5	3.7	1094.0	316.2	3.2	1031.7	344.3	2.8	859.3	300.8	2.7	597.6	212.1	2.6
13.0	1177.9	253.1	4.3	1156.3	284.9	3.8	1121.6	317.4	3.3	1055.6	344.5	2.9	866.2	294.4	2.7	602.7	207.6	2.6

## MODEL: YCAV0307S/P

### AIR TEMPERATURE ON - CONDENSER (°C)

LCWT (°C)	25.0			30.0			35.0			40.0			45.0			50.0		
	KW	KW	COP	KW	KW	COP	KW	KW	COP	KW	KW	COP	KW	KW	COP	KW	KW	COP
5.0	1055.2	260.0	3.7	1036.1	300.0	3.2	1014.7	344.4	2.8	970.6	382.0	2.4	876.1	374.5	2.2	609.6	264.1	2.1
6.0	1084.9	261.7	3.8	1064.9	301.1	3.3	1042.0	345.2	2.8	993.7	381.8	2.5	884.3	366.4	2.3	616.5	258.5	2.2
7.0	1115.3	263.6	3.9	1094.4	302.4	3.4	1069.2	345.6	2.9	1017.4	381.4	2.5	893.8	358.6	2.3	623.2	252.9	2.3
8.0	1146.3	265.7	4.0	1124.5	303.8	3.4	1097.1	346.1	3.0	1041.6	380.9	2.6	904.1	351.2	2.4	629.7	247.5	2.3
9.0	1178.0	268.2	4.0	1155.3	305.5	3.5	1125.4	346.8	3.0	1066.2	380.3	2.6	913.5	343.6	2.5	636.0	242.2	2.4
10.0	1210.2	271.0	4.1	1186.6	307.5	3.6	1154.3	347.5	3.1	1091.1	379.7	2.7	922.5	336.1	2.6	642.1	237.0	2.5
11.0	1243.0	274.2	4.2	1218.5	309.9	3.7	1183.7	348.4	3.2	1116.3	379.2	2.8	930.5	329.0	2.6	648.0	231.9	2.5
12.0	1276.6	277.7	4.2	1251.1	312.4	3.7	1213.7	349.5	3.3	1142.1	378.6	2.8	938.4	322.0	2.7	653.8	226.9	2.6
13.0	1310.6	281.6	4.3	1284.3	315.2	3.8	1244.1	350.9	3.3	1168.3	378.1	2.9	945.9	315.2	2.8	659.3	222.1	2.7

#### NOTES:

1. kW<sub>o</sub> = Unit kW Cooling Capacity Output
2. kW<sub>i</sub> = Compressor kW Input
3. COP = Coefficient of Performance (includes condenser fan power)
4. LCWT = Leaving Chilled Water Temperature
5. Ratings based on 0.15 L/s cooler water per ton, and 0.018 (m<sup>2</sup> - °C)/kW

**MODEL: YCAV0357S/P**

## AIR TEMPERATURE ON - CONDENSER (°C)

LCWT (°C)	25.0			30.0			35.0			40.0			45.0			50.0		
	KW	KW	COP	KW	KW	COP	KW	KW	COP	KW	KW	COP	KW	KW	COP	KW	KW	COP
5.0	1191.3	297.4	3.7	1170.8	339.2	3.2	1147.5	384.9	2.8	1105.5	429.4	2.4	1072.3	467.1	2.2	801.6	360.6	2.1
6.0	1224.9	299.8	3.8	1203.5	341.3	3.3	1179.0	387.1	2.9	1132.5	430.1	2.5	1097.9	468.2	2.2	809.4	353.0	2.1
7.0	1259.1	302.2	3.8	1236.8	343.5	3.3	1211.2	389.4	2.9	1160.1	430.8	2.5	1123.9	469.1	2.3	817.4	345.4	2.2
8.0	1294.0	304.8	3.9	1270.8	345.9	3.4	1244.0	391.8	3.0	1188.2	431.4	2.6	1150.5	470.0	2.3	825.3	337.9	2.3
9.0	1329.5	307.8	4.0	1305.4	348.5	3.5	1277.5	394.4	3.0	1216.8	432.1	2.7	1169.3	465.5	2.4	832.9	330.5	2.3
10.0	1365.7	310.8	4.0	1340.7	351.3	3.6	1311.7	396.9	3.1	1245.7	432.7	2.7	1180.3	455.5	2.5	840.5	323.2	2.4
11.0	1402.6	314.0	4.1	1376.7	354.1	3.6	1346.7	399.6	3.2	1275.0	433.4	2.8	1191.4	445.0	2.5	848.1	316.0	2.5
12.0	1439.8	317.6	4.2	1413.4	357.2	3.7	1382.2	402.6	3.2	1305.0	434.1	2.8	1201.5	433.8	2.6	855.8	309.0	2.6
13.0	1477.6	321.0	4.3	1450.3	360.4	3.7	1418.5	405.6	3.3	1335.5	434.8	2.9	1210.6	422.2	2.7	863.4	302.1	2.6

**MODEL: YCAV0397S/P**

## AIR TEMPERATURE ON - CONDENSER (°C)

LCWT (°C)	25.0			30.0			35.0			40.0			45.0			50.0		
	KW	KW	COP	KW	KW	COP	KW	KW	COP	KW	KW	COP	KW	KW	COP	KW	KW	COP
5.0	1337.3	335.1	3.7	1315.3	380.8	3.2	1289.8	430.8	2.8	1249.5	483.0	2.4	1231.2	537.6	2.2	930.4	418.5	2.1
6.0	1374.7	337.8	3.7	1351.8	383.4	3.3	1325.2	433.5	2.9	1280.8	484.8	2.5	1261.2	539.7	2.2	939.6	409.5	2.1
7.0	1412.9	340.6	3.8	1389.0	386.1	3.3	1361.1	436.5	2.9	1312.9	486.5	2.5	1291.9	541.7	2.3	948.6	400.6	2.2
8.0	1451.9	343.7	3.9	1426.9	389.2	3.4	1397.9	439.5	3.0	1345.7	488.2	2.6	1323.3	543.7	2.3	957.6	391.8	2.3
9.0	1491.4	347.1	4.0	1465.7	392.3	3.5	1435.3	442.7	3.0	1379.2	489.9	2.7	1344.8	538.0	2.4	966.4	383.2	2.3
10.0	1531.8	350.5	4.0	1505.1	395.5	3.5	1473.6	445.8	3.1	1412.8	491.7	2.7	1355.8	524.7	2.4	975.0	374.6	2.4
11.0	1572.9	354.1	4.1	1545.3	398.8	3.6	1512.7	449.1	3.2	1447.4	493.5	2.8	1368.1	512.0	2.5	983.5	366.3	2.5
12.0	1613.6	357.9	4.2	1586.1	402.5	3.7	1552.4	452.5	3.2	1482.4	495.3	2.8	1380.2	499.5	2.6	991.8	358.0	2.6
13.0	0.0	0.0	0.0	1626.5	406.1	3.7	1593.0	456.1	3.3	1518.1	497.1	2.9	1391.8	487.3	2.7	999.8	350.0	2.6

**MODEL: YCAV0417S/P**

## AIR TEMPERATURE ON - CONDENSER (°C)

LCWT (°C)	25.0			30.0			35.0			40.0			45.0			50.0		
	KW	KW	COP	KW	KW	COP	KW	KW	COP	KW	KW	COP	KW	KW	COP	KW	KW	COP
5.0	1421.9	355.6	3.7	1399.6	408.9	3.2	1374.2	467.3	2.7	1329.7	525.5	2.4	1280.0	563.9	2.1	1008.9	466.4	2.0
6.0	1460.7	357.8	3.7	1437.4	410.5	3.2	1411.0	469.1	2.8	1361.9	525.6	2.4	1310.0	564.8	2.2	1019.2	456.6	2.1
7.0	1500.2	360.2	3.8	1475.9	412.3	3.3	1448.3	470.8	2.9	1394.3	525.6	2.5	1340.7	565.4	2.2	1028.3	446.7	2.1
8.0	1540.4	362.7	3.9	1515.1	414.3	3.4	1486.3	472.7	2.9	1426.7	525.4	2.6	1372.1	565.8	2.3	1038.3	437.3	2.2
9.0	1581.3	365.6	4.0	1555.0	416.6	3.5	1524.9	474.9	3.0	1459.6	525.2	2.6	1404.0	566.0	2.3	1048.3	427.9	2.3
10.0	1622.8	368.9	4.0	1595.7	419.0	3.5	1564.3	477.1	3.1	1493.0	524.9	2.7	1435.3	566.1	2.4	1058.2	418.6	2.3
11.0	1665.1	372.3	4.1	1637.0	421.8	3.6	1604.4	479.4	3.1	1526.9	524.5	2.7	1467.4	566.0	2.5	1067.9	409.3	2.4
12.0	1708.0	376.1	4.2	1678.8	424.9	3.7	1645.2	481.9	3.2	1560.9	524.3	2.8	1500.0	565.7	2.5	1077.5	400.3	2.5
13.0	1751.7	380.1	4.2	1721.5	428.2	3.7	1686.7	484.6	3.3	1595.7	524.0	2.9	1522.4	565.2	2.6	1087.1	391.3	2.6

**NOTES:**

1. kW<sub>o</sub> = Unit kW Cooling Capacity Output
2. kW<sub>i</sub> = Compressor kW Input
3. COP = Coefficient of Performance (includes condenser fan power)
4. LCWT = Leaving Chilled Water Temperature
5. Ratings based on 0.15 L/s cooler water per ton, and 0.018 (m<sup>2</sup> - °C)/kW

# Standard Efficiency Ratings - SI - 60Hz

## MODEL: YCAV0457S/P

### AIR TEMPERATURE ON - CONDENSER (°C)

LCWT (°C)	25.0			30.0			35.0			40.0			45.0			50.0		
	KW	KW	COP	KW	KW	COP	KW	KW	COP	KW	KW	COP	KW	KW	COP	KW	KW	COP
5.0	1521.5	389.5	3.6	1495.7	444.2	3.1	1465.6	504.4	2.7	1418.8	566.0	2.4	1332.8	585.7	2.2	931.5	409.2	2.1
6.0	1563.0	392.3	3.7	1536.3	446.8	3.2	1505.5	507.1	2.8	1453.9	567.2	2.4	1346.3	573.8	2.2	942.0	400.7	2.2
7.0	1605.2	395.4	3.7	1577.6	449.7	3.3	1545.7	509.9	2.8	1489.5	568.4	2.5	1358.2	560.8	2.3	951.3	391.7	2.2
8.0	1648.1	398.6	3.8	1619.7	452.6	3.3	1586.6	512.8	2.9	1525.7	569.5	2.5	1368.0	546.3	2.4	961.3	383.4	2.3
9.0	1691.7	402.2	3.9	1662.5	455.8	3.4	1628.2	515.8	3.0	1562.2	570.6	2.6	1378.8	532.6	2.4	970.9	375.0	2.4
10.0	1735.9	405.9	3.9	1705.9	459.1	3.5	1669.7	518.7	3.0	1599.3	571.6	2.6	1389.7	519.5	2.5	980.3	366.9	2.4
11.0	1780.8	409.9	4.0	1750.0	462.7	3.5	1712.0	521.5	3.1	1636.9	572.7	2.7	1400.9	507.3	2.6	989.2	358.7	2.5
12.0	1826.3	414.1	4.1	1794.7	466.5	3.6	1754.9	524.5	3.1	1674.7	574.0	2.8	1412.4	495.9	2.7	997.6	350.9	2.6
13.0	1872.5	418.5	4.1	1840.1	470.5	3.6	1798.3	527.7	3.2	1713.2	575.2	2.8	1423.8	484.9	2.7	1006.0	343.1	2.7

## MODEL: YCAV0477S/P

### AIR TEMPERATURE ON - CONDENSER (°C)

LCWT (°C)	25.0			30.0			35.0			40.0			45.0			50.0		
	KW	KW	COP	KW	KW	COP	KW	KW	COP	KW	KW	COP	KW	KW	COP	KW	KW	COP
5.0	1635.6	409.2	3.7	1607.9	466.2	3.2	1576.2	528.7	2.8	1521.2	590.6	2.4	1482.1	646.6	2.2	1111.6	500.2	2.1
6.0	1681.6	412.4	3.7	1652.7	469.2	3.3	1619.5	531.7	2.9	1558.7	592.0	2.5	1517.6	648.4	2.2	1122.5	489.6	2.1
7.0	1728.6	415.8	3.8	1698.5	472.3	3.3	1663.7	535.0	2.9	1596.9	593.2	2.5	1553.9	650.0	2.3	1133.5	479.0	2.2
8.0	1776.5	419.5	3.9	1745.1	475.8	3.4	1708.8	538.5	3.0	1635.9	594.4	2.6	1590.9	651.5	2.3	1144.3	468.5	2.3
9.0	1825.2	423.5	4.0	1792.7	479.3	3.5	1754.8	542.1	3.0	1675.6	595.6	2.7	1617.2	645.3	2.4	1154.9	458.3	2.3
10.0	1874.3	427.6	4.0	1841.1	483.2	3.5	1801.8	545.7	3.1	1715.8	596.9	2.7	1631.9	630.8	2.4	1165.4	448.1	2.4
11.0	1923.9	432.0	4.1	1889.8	487.1	3.6	1849.8	549.5	3.2	1756.7	598.2	2.8	1647.1	616.0	2.5	1175.9	438.1	2.5
12.0	1974.2	436.8	4.2	1939.1	491.4	3.7	1897.8	553.5	3.2	1798.4	599.4	2.8	1661.3	600.6	2.6	1186.3	428.3	2.6
13.0	2025.6	441.5	4.2	1989.2	495.8	3.7	1946.6	557.6	3.3	1840.8	600.8	2.9	1674.4	584.9	2.7	1196.6	418.7	2.6

#### NOTES:

1. kW<sub>o</sub> = Unit kW Cooling Capacity Output
2. kW<sub>i</sub> = Compressor kW Input
3. COP = Coefficient of Performance (includes condenser fan power)
4. LCWT = Leaving Chilled Water Temperature
5. Ratings based on 0.15 L/s cooler water per ton, and 0.018 (m<sup>2</sup> - °C)/kW

**MODEL: YCAV0507S/P****AIR TEMPERATURE ON - CONDENSER (°C)**

LCWT (°C)	25.0			30.0			35.0			40.0			45.0			50.0		
	KW	KW	COP	KW	KW	COP	KW	KW	COP	KW	KW	COP	KW	KW	COP	KW	KW	COP
5.0	1708.2	427.8	3.7	1679.7	486.9	3.2	1647.0	551.5	2.8	1593.0	617.4	2.4	1561.4	681.8	2.2	1176.0	529.0	2.1
6.0	1756.1	431.4	3.7	1726.5	490.1	3.3	1692.2	554.9	2.9	1632.6	619.3	2.5	1599.1	684.1	2.2	1187.6	517.7	2.1
7.0	1805.1	435.0	3.8	1774.2	493.6	3.3	1738.3	558.5	2.9	1673.2	621.0	2.5	1637.7	686.2	2.3	1199.1	506.5	2.2
8.0	1855.0	438.8	3.9	1822.8	497.4	3.4	1785.4	562.2	3.0	1714.5	622.7	2.6	1677.1	688.3	2.3	1210.5	495.4	2.3
9.0	1905.7	443.1	4.0	1872.4	501.1	3.5	1833.3	566.2	3.0	1756.5	624.4	2.7	1704.8	681.6	2.4	1221.7	484.5	2.3
10.0	1956.6	447.4	4.0	1922.9	505.2	3.5	1882.4	570.1	3.1	1799.1	626.3	2.7	1719.6	665.4	2.4	1232.7	473.7	2.4
11.0	2007.8	451.9	4.1	1973.3	509.3	3.6	1932.4	574.1	3.2	1842.6	628.1	2.8	1735.4	649.5	2.5	1243.5	463.2	2.5
12.0	2059.7	456.8	4.2	2024.1	513.9	3.7	1982.1	578.4	3.2	1886.8	629.9	2.8	1750.5	633.4	2.6	1254.3	452.8	2.6
13.0	2112.8	461.4	4.2	2075.9	518.4	3.7	2032.5	582.7	3.3	1931.8	631.9	2.9	1764.9	617.5	2.7	1264.8	442.7	2.6

**MODEL: YCAV0527S/P****AIR TEMPERATURE ON - CONDENSER (°C)**

LCWT (°C)	25.0			30.0			35.0			40.0			45.0			50.0		
	KW	KW	COP	KW	KW	COP	KW	KW	COP	KW	KW	COP	KW	KW	COP	KW	KW	COP
5.0	1780.9	446.4	3.7	1751.7	507.5	3.2	1718.0	574.3	2.8	1665.0	644.0	2.4	1640.7	716.8	2.2	1240.7	557.8	2.1
6.0	1830.8	450.2	3.7	1800.4	511.0	3.3	1765.1	577.9	2.9	1706.7	646.4	2.5	1680.7	719.5	2.2	1252.9	545.9	2.1
7.0	1881.8	454.0	3.8	1850.1	514.7	3.3	1813.1	581.9	2.9	1749.5	648.6	2.5	1721.7	722.2	2.3	1265.0	534.0	2.2
8.0	1933.7	458.1	3.9	1900.6	518.8	3.4	1862.1	585.8	3.0	1793.2	650.8	2.6	1763.5	724.8	2.3	1277.0	522.3	2.3
9.0	1986.4	462.6	4.0	1952.3	522.9	3.5	1912.1	590.1	3.0	1837.6	653.1	2.7	1792.8	717.7	2.4	1288.7	510.7	2.3
10.0	2039.1	467.0	4.0	2004.9	527.1	3.5	1963.1	594.3	3.1	1882.6	655.6	2.7	1807.5	699.9	2.4	1300.1	499.3	2.4
11.0	2091.9	471.6	4.1	2056.9	531.5	3.6	2015.2	598.7	3.2	1928.6	657.9	2.8	1823.9	682.9	2.5	1311.5	488.2	2.5
12.0	2145.4	476.7	4.2	2109.3	536.2	3.7	2066.6	603.1	3.2	1975.4	660.3	2.8	1840.1	666.2	2.6	1322.6	477.2	2.6
13.0	2200.1	481.3	4.2	2162.6	541.0	3.7	2118.6	607.7	3.3	2023.0	662.8	2.9	1855.6	650.0	2.7	1333.2	466.5	2.6

**NOTES:**

1. kW<sub>o</sub> = Unit kW Cooling Capacity Output
2. kW<sub>i</sub> = Compressor kW Input
3. COP = Coefficient of Performance (includes condenser fan power)
4. LCWT = Leaving Chilled Water Temperature
5. Ratings based on 0.15 L/s cooler water per ton, and 0.018 (m<sup>2</sup> - °C)/kW

# High Efficiency Ratings - SI - 60Hz

## MODEL: YCAV0157E/V

### AIR TEMPERATURE ON - CONDENSER (°C)

LCWT (°C)	25.0			30.0			35.0			40.0			45.0			50.0		
	KW	KW	COP	KW	KW	COP	KW	KW	COP	KW	KW	COP	KW	KW	COP	KW	KW	COP
5.0	525.0	125.6	3.8	515.6	141.9	3.3	503.3	159.4	2.9	487.8	180.0	2.5	464.9	201.9	2.2	379.5	184.8	1.9
6.0	539.7	126.6	3.9	530.4	143.0	3.4	518.1	160.6	3.0	500.9	180.9	2.6	477.0	202.7	2.2	383.6	181.1	2.0
7.0	554.7	127.6	3.9	545.4	144.1	3.5	533.0	161.8	3.0	514.0	181.8	2.6	489.2	203.6	2.3	387.7	177.4	2.0
8.0	569.9	128.7	4.0	560.7	145.3	3.5	548.1	163.0	3.1	527.2	182.7	2.7	501.4	204.5	2.3	391.7	173.8	2.1
9.0	585.2	129.7	4.1	576.2	146.4	3.6	563.5	164.2	3.2	540.5	183.7	2.7	514.1	205.5	2.4	395.7	170.2	2.2
10.0	600.7	130.8	4.2	591.8	147.6	3.7	579.1	165.5	3.2	554.0	184.6	2.8	527.1	206.4	2.4	399.6	166.7	2.2
11.0	616.4	131.8	4.2	607.7	148.8	3.8	594.9	166.9	3.3	567.6	185.6	2.9	540.1	207.3	2.5	403.4	163.2	2.3
12.0	632.2	132.9	4.3	623.8	150.0	3.8	610.9	168.2	3.4	581.2	186.6	2.9	553.3	208.3	2.5	407.1	159.7	2.4
13.0	648.3	134.0	4.4	640.1	151.3	3.9	627.2	169.6	3.4	595.0	187.6	3.0	566.7	209.3	2.5	410.9	156.3	2.4

## MODEL: YCAV0177E/V

### AIR TEMPERATURE ON - CONDENSER (°C)

LCWT (°C)	25.0			30.0			35.0			40.0			45.0			50.0		
	KW	KW	COP	KW	KW	COP	KW	KW	COP	KW	KW	COP	KW	KW	COP	KW	KW	COP
5.0	558.7	131.8	3.8	550.3	150.1	3.3	540.3	170.4	2.9	525.1	193.6	2.5	509.7	219.8	2.2	389.5	180.5	2.0
6.0	574.5	132.8	3.9	565.7	150.9	3.4	555.3	171.2	3.0	538.7	194.3	2.6	522.0	220.5	2.2	393.8	176.9	2.1
7.0	590.5	133.8	4.0	581.5	151.8	3.5	570.6	172.1	3.1	552.7	194.9	2.6	534.6	221.1	2.3	398.0	173.3	2.1
8.0	606.9	134.9	4.1	597.5	152.8	3.6	586.3	172.9	3.1	566.8	195.6	2.7	547.4	221.7	2.3	402.1	169.8	2.2
9.0	623.5	136.1	4.1	613.9	153.8	3.6	602.3	173.9	3.2	581.3	196.3	2.8	560.4	222.3	2.4	406.2	166.3	2.2
10.0	640.4	137.4	4.2	630.5	154.9	3.7	618.5	174.9	3.3	596.0	197.1	2.8	573.6	222.8	2.4	410.1	162.9	2.3
11.0	657.7	138.8	4.3	647.5	156.1	3.8	635.1	176.0	3.3	610.9	197.8	2.9	587.1	223.4	2.5	414.0	159.5	2.4
12.0	675.2	140.2	4.4	664.8	157.4	3.9	652.0	177.1	3.4	626.1	198.6	2.9	596.4	220.7	2.5	417.8	156.2	2.4
13.0	693.1	141.8	4.4	682.3	158.7	3.9	669.2	178.3	3.5	641.6	199.5	3.0	602.4	215.6	2.6	421.5	152.8	2.5

## MODEL: YCAV0187E/V

### AIR TEMPERATURE ON - CONDENSER (°C)

LCWT (°C)	25.0			30.0			35.0			40.0			45.0			50.0		
	KW	KW	COP	KW	KW	COP	KW	KW	COP	KW	KW	COP	KW	KW	COP	KW	KW	COP
5.0	621.1	146.3	3.8	611.6	167.4	3.3	600.1	190.8	2.9	582.8	216.0	2.5	566.5	238.4	2.2	448.5	202.5	2.0
6.0	638.5	147.3	3.9	628.9	168.2	3.4	617.0	191.5	3.0	598.1	216.4	2.6	580.5	238.8	2.3	452.8	198.2	2.1
7.0	656.2	148.3	4.0	646.4	169.0	3.5	634.2	192.3	3.0	613.8	216.7	2.6	594.8	239.2	2.3	457.4	194.1	2.2
8.0	674.1	149.4	4.1	664.2	169.9	3.6	651.7	193.2	3.1	629.7	217.0	2.7	609.3	239.6	2.4	461.7	189.9	2.2
9.0	692.3	150.7	4.1	682.2	170.9	3.6	669.4	194.1	3.2	645.8	217.3	2.8	624.1	239.9	2.4	466.0	185.7	2.3
10.0	710.7	152.1	4.2	700.4	172.0	3.7	687.3	195.0	3.2	662.3	217.6	2.8	639.0	240.1	2.5	470.1	181.6	2.4
11.0	729.4	153.5	4.3	719.0	173.2	3.8	705.6	196.1	3.3	678.9	218.0	2.9	654.3	240.4	2.5	474.3	177.6	2.4
12.0	748.4	155.1	4.4	737.8	174.6	3.9	724.1	197.2	3.4	695.7	218.3	3.0	669.8	240.6	2.6	478.3	173.6	2.5
13.0	767.7	156.8	4.4	756.9	176.0	3.9	742.9	198.5	3.5	712.8	218.7	3.0	682.8	239.0	2.7	482.4	169.7	2.6

#### NOTES:

1. kW<sub>o</sub> = Unit kW Cooling Capacity Output
2. kW<sub>i</sub> = Compressor kW Input
3. COP = Coefficient of Performance (includes condenser fan power)
4. LCWT = Leaving Chilled Water Temperature
5. Ratings based on 0.15 L/s cooler water per ton, and 0.018 (m<sup>2</sup> - °C)/kW

**MODEL: YCAV0197E/V**

## AIR TEMPERATURE ON - CONDENSER (°C)

LCWT (°C)	25.0			30.0			35.0			40.0			45.0			50.0		
	KW	KW	COP	KW	KW	COP	KW	KW	COP	KW	KW	COP	KW	KW	COP	KW	KW	COP
5.0	672.7	158.3	3.8	661.6	182.6	3.3	648.7	210.3	2.9	631.4	241.5	2.4	607.1	260.8	2.2	498.8	229.4	2.0
6.0	691.7	159.3	3.9	680.1	183.1	3.4	666.7	210.7	2.9	647.0	241.1	2.5	621.7	260.9	2.2	503.2	224.4	2.1
7.0	711.0	160.5	4.0	699.0	183.7	3.5	685.1	211.1	3.0	662.9	240.6	2.6	636.5	260.9	2.3	508.1	219.7	2.2
8.0	730.8	162.0	4.1	718.3	184.6	3.6	703.9	211.6	3.1	678.8	240.1	2.6	651.7	260.7	2.4	513.0	215.0	2.2
9.0	750.9	163.6	4.2	737.9	185.6	3.7	723.0	212.2	3.2	695.2	239.6	2.7	667.2	260.4	2.4	517.9	210.3	2.3
10.0	771.3	165.6	4.2	758.0	186.7	3.7	742.4	213.0	3.2	711.9	239.0	2.8	682.9	260.0	2.5	522.6	205.7	2.4
11.0	792.1	167.8	4.3	778.4	188.1	3.8	762.2	213.9	3.3	728.8	238.5	2.9	698.9	259.5	2.5	527.4	201.1	2.4
12.0	813.3	170.2	4.4	799.1	189.8	3.9	782.4	214.9	3.4	745.9	238.1	2.9	715.0	259.0	2.6	532.0	196.6	2.5
13.0	834.9	172.9	4.4	820.2	191.6	3.9	803.0	216.1	3.5	763.0	237.8	3.0	731.6	258.5	2.7	536.6	192.1	2.6

**MODEL: YCAV0207E/V**

## AIR TEMPERATURE ON - CONDENSER (°C)

LCWT (°C)	25.0			30.0			35.0			40.0			45.0			50.0		
	KW	KW	COP	KW	KW	COP	KW	KW	COP	KW	KW	COP	KW	KW	COP	KW	KW	COP
5.0	715.1	166.5	3.9	703.9	191.2	3.4	691.1	219.2	2.9	672.4	250.0	2.5	652.7	273.2	2.2	514.8	227.2	2.1
6.0	735.3	167.7	4.0	723.6	191.9	3.4	710.2	219.8	3.0	689.7	250.2	2.6	668.3	273.3	2.3	519.5	222.3	2.2
7.0	755.9	169.0	4.0	743.7	192.7	3.5	729.7	220.4	3.1	707.4	250.3	2.6	684.3	273.3	2.4	524.7	217.6	2.2
8.0	776.9	170.5	4.1	764.2	193.7	3.6	749.5	221.1	3.1	725.4	250.4	2.7	700.4	273.2	2.4	529.7	213.0	2.3
9.0	798.4	172.3	4.2	785.1	194.9	3.7	769.8	222.0	3.2	743.7	250.5	2.8	717.0	272.9	2.5	534.8	208.4	2.4
10.0	820.2	174.2	4.3	806.4	196.2	3.8	790.5	222.9	3.3	762.5	250.6	2.8	733.7	272.6	2.5	539.7	203.8	2.4
11.0	842.4	176.4	4.3	828.1	197.7	3.8	811.6	223.9	3.4	781.3	250.8	2.9	750.9	272.3	2.6	544.5	199.3	2.5
12.0	864.5	178.7	4.4	850.1	199.4	3.9	833.1	225.2	3.4	799.5	250.5	3.0	768.2	271.9	2.7	549.3	194.9	2.6
13.0	887.0	181.3	4.4	872.1	201.3	4.0	854.8	226.6	3.5	818.1	250.3	3.0	780.0	267.9	2.7	553.9	190.5	2.7

**MODEL: YCAV0227E/V**

## AIR TEMPERATURE ON - CONDENSER (°C)

LCWT (°C)	25.0			30.0			35.0			40.0			45.0			50.0		
	KW	KW	COP	KW	KW	COP	KW	KW	COP	KW	KW	COP	KW	KW	COP	KW	KW	COP
5.0	743.0	172.5	3.9	731.8	196.6	3.4	718.8	223.9	3.0	703.0	255.9	2.6	685.2	280.8	2.3	614.8	279.7	2.1
6.0	764.0	173.7	3.9	752.3	197.7	3.5	738.8	224.8	3.0	722.2	256.8	2.6	701.8	280.9	2.3	620.1	274.4	2.1
7.0	785.4	175.2	4.0	773.3	198.8	3.5	759.2	225.7	3.1	741.8	257.9	2.7	718.6	281.0	2.4	625.7	268.9	2.2
8.0	807.2	176.7	4.1	794.7	200.0	3.6	780.0	226.8	3.2	761.9	259.0	2.7	735.8	281.1	2.4	631.4	263.2	2.2
9.0	829.4	178.3	4.2	816.5	201.3	3.7	801.2	227.9	3.2	782.3	260.0	2.8	753.3	281.1	2.5	637.5	257.2	2.3
10.0	851.7	180.1	4.3	838.7	202.8	3.8	822.9	229.1	3.3	801.1	260.0	2.9	771.2	281.0	2.6	643.5	251.2	2.4
11.0	874.2	182.1	4.3	860.8	204.3	3.8	844.9	230.4	3.4	820.0	260.1	2.9	789.1	281.0	2.6	649.6	245.2	2.5
12.0	897.1	184.2	4.4	883.2	206.0	3.9	866.8	231.9	3.4	839.3	260.1	3.0	807.6	280.9	2.7	655.5	239.3	2.5
13.0	920.3	186.4	4.5	906.1	207.7	4.0	889.1	233.4	3.5	858.7	260.2	3.1	826.3	280.8	2.8	661.0	233.7	2.6

**NOTES:**

1. kW<sub>o</sub> = Unit kW Cooling Capacity Output
2. kW<sub>i</sub> = Compressor kW Input
3. COP = Coefficient of Performance (includes condenser fan power)
4. LCWT = Leaving Chilled Water Temperature
5. Ratings based on 0.15 L/s cooler water per ton, and 0.018 (m<sup>2</sup> - °C)/kW

# High Efficiency Ratings - SI - 60Hz

## MODEL: YCAV0247E/V

### AIR TEMPERATURE ON - CONDENSER (°C)

LCWT (°C)	25.0			30.0			35.0			40.0			45.0			50.0		
	KW	KW	COP	KW	KW	COP	KW	KW	COP	KW	KW	COP	KW	KW	COP	KW	KW	COP
5.0	824.5	198.8	3.8	811.2	226.0	3.3	795.7	256.3	2.9	773.5	289.6	2.5	757.4	320.2	2.2	563.2	246.0	2.1
6.0	847.7	200.4	3.8	833.8	227.5	3.4	817.7	257.7	2.9	793.8	290.7	2.6	775.8	320.9	2.3	568.9	240.7	2.2
7.0	871.3	202.1	3.9	856.9	229.0	3.4	840.1	259.2	3.0	814.6	291.8	2.6	794.7	321.6	2.3	574.4	235.5	2.3
8.0	895.3	204.0	4.0	880.5	230.7	3.5	863.0	260.8	3.1	835.8	292.9	2.7	814.0	322.3	2.4	579.8	230.4	2.3
9.0	919.9	206.0	4.1	904.5	232.4	3.6	886.3	262.5	3.1	856.8	293.7	2.7	821.9	315.3	2.5	585.1	225.3	2.4
10.0	944.8	208.1	4.1	928.9	234.3	3.7	910.1	264.2	3.2	877.5	294.4	2.8	829.9	308.0	2.5	590.4	220.3	2.5
11.0	970.3	210.4	4.2	953.8	236.3	3.7	934.4	266.0	3.3	898.6	295.0	2.9	837.4	300.3	2.6	595.6	215.4	2.5
12.0	995.9	212.9	4.3	979.1	238.4	3.8	959.0	267.9	3.3	920.1	295.6	2.9	844.4	292.5	2.7	600.9	210.6	2.6
13.0	1022.2	214.8	4.4	1004.7	240.7	3.9	984.2	270.0	3.4	941.9	296.3	3.0	850.7	284.8	2.8	605.8	205.9	2.7

## MODEL: YCAV0267E/V

### AIR TEMPERATURE ON - CONDENSER (°C)

LCWT (°C)	25.0			30.0			35.0			40.0			45.0			50.0		
	KW	KW	COP	KW	KW	COP	KW	KW	COP	KW	KW	COP	KW	KW	COP	KW	KW	COP
5.0	935.9	218.7	3.9	919.5	251.0	3.4	900.1	287.1	2.9	875.5	328.5	2.5	840.4	358.3	2.2	696.6	325.1	2.0
6.0	962.5	220.1	4.0	945.8	252.0	3.4	925.6	288.1	3.0	898.2	328.8	2.6	861.1	358.9	2.3	703.3	318.3	2.1
7.0	989.5	221.7	4.0	972.5	253.1	3.5	951.7	289.0	3.0	921.3	328.9	2.6	882.0	359.4	2.3	710.4	311.7	2.1
8.0	1017.1	223.6	4.1	999.6	254.5	3.6	978.3	290.1	3.1	944.1	328.9	2.7	903.6	359.7	2.4	717.2	305.1	2.2
9.0	1045.2	225.6	4.2	1027.4	256.0	3.7	1005.4	291.3	3.2	967.3	328.8	2.8	925.4	360.0	2.4	724.0	298.6	2.3
10.0	1073.8	227.9	4.3	1055.6	257.6	3.8	1033.0	292.7	3.3	991.0	328.8	2.8	947.7	360.1	2.5	730.8	292.1	2.3
11.0	1102.8	230.5	4.3	1084.4	259.5	3.8	1061.2	294.2	3.3	1015.0	328.8	2.9	970.5	360.1	2.5	737.3	285.7	2.4
12.0	1132.3	233.4	4.4	1113.6	261.7	3.9	1089.8	295.8	3.4	1039.3	328.8	3.0	993.5	360.2	2.6	743.9	279.3	2.5
13.0	1162.3	236.4	4.5	1143.3	264.0	4.0	1119.1	297.6	3.5	1063.8	328.9	3.0	1017.0	360.2	2.7	750.4	273.1	2.5

## MODEL: YCAV0287E/V

### AIR TEMPERATURE ON - CONDENSER (°C)

LCWT (°C)	25.0			30.0			35.0			40.0			45.0			50.0		
	KW	KW	COP	KW	KW	COP	KW	KW	COP	KW	KW	COP	KW	KW	COP	KW	KW	COP
5.0	996.2	229.9	3.9	979.2	265.0	3.4	959.5	304.9	2.9	935.5	351.4	2.5	900.4	380.5	2.2	758.5	348.2	2.0
6.0	1024.5	231.3	4.0	1007.0	265.7	3.5	986.4	305.6	3.0	960.5	351.8	2.6	922.3	380.7	2.3	765.3	340.6	2.1
7.0	1053.4	233.1	4.1	1035.3	266.7	3.6	1013.9	306.1	3.1	984.3	351.2	2.6	944.6	380.6	2.3	772.8	333.6	2.2
8.0	1082.9	235.1	4.2	1064.2	267.8	3.6	1042.0	306.9	3.1	1008.6	350.5	2.7	967.2	380.5	2.4	780.2	326.5	2.2
9.0	1112.9	237.5	4.2	1093.7	269.3	3.7	1070.7	307.8	3.2	1033.1	349.9	2.8	990.4	380.1	2.4	787.7	319.5	2.3
10.0	1143.5	240.2	4.3	1123.7	271.0	3.8	1100.0	309.0	3.3	1058.1	349.1	2.8	1014.2	379.6	2.5	795.1	312.6	2.4
11.0	1174.4	243.3	4.4	1154.4	273.0	3.9	1129.9	310.2	3.4	1083.6	348.5	2.9	1038.3	379.0	2.6	802.3	305.7	2.4
12.0	1206.4	246.8	4.4	1185.5	275.4	3.9	1160.4	311.7	3.4	1109.5	347.9	3.0	1062.9	378.3	2.6	809.4	299.0	2.5
13.0	1238.7	250.7	4.5	1217.3	278.0	4.0	1191.4	313.5	3.5	1135.6	347.4	3.1	1087.6	377.7	2.7	816.5	292.3	2.6

#### NOTES:

1. kW<sub>o</sub> = Unit kW Cooling Capacity Output
2. kW<sub>i</sub> = Compressor kW Input
3. COP = Coefficient of Performance (includes condenser fan power)
4. LCWT = Leaving Chilled Water Temperature
5. Ratings based on 0.15 L/s cooler water per ton, and 0.018 (m<sup>2</sup> - °C)/kW



**MODEL: YCAV0327E/V**

## AIR TEMPERATURE ON - CONDENSER (°C)

LCWT (°C)	25.0			30.0			35.0			40.0			45.0			50.0		
	KW	KW	COP	KW	KW	COP	KW	KW	COP	KW	KW	COP	KW	KW	COP	KW	KW	COP
5.0	1082.7	253.0	3.9	1064.7	290.5	3.4	1044.3	333.1	2.9	1013.0	378.6	2.5	979.4	411.6	2.2	771.5	343.4	2.1
6.0	1113.5	254.7	4.0	1094.7	291.6	3.4	1073.2	334.0	3.0	1038.5	378.7	2.6	1002.8	411.8	2.3	778.6	336.0	2.2
7.0	1145.0	256.7	4.0	1125.3	292.9	3.5	1102.8	335.0	3.1	1064.7	378.6	2.6	1026.6	411.8	2.3	786.2	329.0	2.2
8.0	1177.1	259.0	4.1	1156.5	294.4	3.6	1133.0	336.2	3.1	1091.4	378.6	2.7	1050.8	411.7	2.4	793.7	322.0	2.3
9.0	1209.8	261.7	4.2	1188.4	296.2	3.7	1164.0	337.5	3.2	1118.6	378.5	2.8	1075.6	411.4	2.5	801.3	315.1	2.3
10.0	1243.2	264.6	4.3	1221.0	298.3	3.8	1195.5	338.9	3.3	1146.4	378.5	2.8	1100.7	411.0	2.5	808.6	308.3	2.4
11.0	1277.2	267.9	4.3	1254.2	300.7	3.8	1227.8	340.6	3.3	1174.3	378.4	2.9	1126.5	410.5	2.6	816.0	301.5	2.5
12.0	1311.9	271.6	4.4	1288.1	303.3	3.9	1260.7	342.5	3.4	1201.8	378.0	3.0	1152.6	410.0	2.6	823.1	294.9	2.6
13.0	1347.3	275.7	4.5	1322.6	306.1	4.0	1294.1	344.8	3.5	1229.8	377.6	3.0	1170.5	404.2	2.7	830.2	288.2	2.6

**MODEL: YCAV0357E/V**

## AIR TEMPERATURE ON - CONDENSER (°C)

LCWT (°C)	25.0			30.0			35.0			40.0			45.0			50.0		
	KW	KW	COP	KW	KW	COP	KW	KW	COP	KW	KW	COP	KW	KW	COP	KW	KW	COP
5.0	1228.4	292.9	3.8	1206.7	332.0	3.3	1181.0	375.3	2.9	1146.5	424.4	2.5	1124.2	471.7	2.2	875.6	387.7	2.1
6.0	1263.2	295.5	3.9	1241.1	334.3	3.4	1214.5	377.6	3.0	1177.1	426.0	2.6	1152.5	473.1	2.3	884.3	379.5	2.2
7.0	1298.8	298.2	4.0	1276.1	336.8	3.5	1248.7	379.9	3.0	1208.5	427.5	2.6	1181.6	474.3	2.3	892.9	371.3	2.2
8.0	1334.9	301.0	4.0	1311.8	339.4	3.6	1283.4	382.5	3.1	1240.5	429.2	2.7	1211.3	475.5	2.4	901.4	363.2	2.3
9.0	1371.6	304.2	4.1	1348.0	342.3	3.6	1318.9	385.1	3.2	1273.1	430.8	2.8	1241.6	476.7	2.5	909.7	355.2	2.4
10.0	1409.1	307.4	4.2	1384.9	345.2	3.7	1355.0	388.0	3.2	1306.1	432.6	2.8	1272.4	478.0	2.5	917.9	347.3	2.4
11.0	1447.1	310.9	4.2	1422.5	348.3	3.8	1391.8	390.9	3.3	1339.8	434.4	2.9	1296.7	474.5	2.6	926.0	339.6	2.5
12.0	1485.7	314.6	4.3	1460.6	351.7	3.8	1429.2	394.0	3.4	1372.9	435.7	3.0	1307.9	462.5	2.7	934.0	332.0	2.6
13.0	1525.2	317.4	4.4	1499.4	355.2	3.9	1467.3	397.2	3.4	1406.5	437.2	3.0	1318.4	450.7	2.7	941.8	324.6	2.7

**MODEL: YCAV0397E/V**

## AIR TEMPERATURE ON - CONDENSER (°C)

LCWT (°C)	25.0			30.0			35.0			40.0			45.0			50.0		
	KW	KW	COP	KW	KW	COP	KW	KW	COP	KW	KW	COP	KW	KW	COP	KW	KW	COP
5.0	1311.3	305.8	3.9	1289.5	353.0	3.3	1264.6	406.2	2.9	1234.0	468.0	2.5	1190.2	507.1	2.2	1009.0	466.4	2.0
6.0	1348.7	307.5	4.0	1326.3	353.9	3.4	1300.1	407.0	3.0	1268.1	469.3	2.5	1219.1	507.5	2.3	1019.4	456.7	2.1
7.0	1386.9	309.7	4.0	1363.8	355.0	3.5	1336.4	407.8	3.0	1299.9	468.6	2.6	1248.8	507.6	2.3	1028.3	446.7	2.1
8.0	1424.6	312.1	4.1	1401.9	356.4	3.6	1373.5	408.7	3.1	1332.1	467.7	2.7	1278.7	507.4	2.4	1038.3	437.2	2.2
9.0	1462.7	314.9	4.2	1439.2	358.2	3.7	1411.1	409.8	3.2	1364.5	466.8	2.7	1309.6	507.0	2.4	1048.3	427.9	2.3
10.0	1501.5	318.1	4.3	1477.4	360.1	3.8	1448.4	411.1	3.3	1397.8	465.9	2.8	1341.0	506.3	2.5	1058.3	418.6	2.3
11.0	1540.7	321.9	4.3	1516.1	362.4	3.8	1486.3	412.7	3.3	1431.1	465.0	2.9	1373.1	505.6	2.6	1067.9	409.3	2.4
12.0	1580.6	326.0	4.4	1555.5	365.1	3.9	1524.9	414.5	3.4	1464.2	464.2	2.9	1405.7	504.7	2.6	1077.5	400.3	2.5
13.0	1621.3	330.6	4.5	1595.4	368.3	4.0	1564.1	416.5	3.5	1497.8	463.5	3.0	1438.1	503.9	2.7	1087.1	391.3	2.6

**NOTES:**

1. kW<sub>o</sub> = Unit kW Cooling Capacity Output
2. kW<sub>i</sub> = Compressor kW Input
3. COP = Coefficient of Performance (includes condenser fan power)
4. LCWT = Leaving Chilled Water Temperature
5. Ratings based on 0.15 L/s cooler water per ton, and 0.018 (m<sup>2</sup> - °C)/kW

# High Efficiency Ratings - SI - 60Hz

## MODEL: YCAV0417E/V

### AIR TEMPERATURE ON - CONDENSER (°C)

LCWT (°C)	25.0			30.0			35.0			40.0			45.0			50.0		
	KW	KW	COP	KW	KW	COP	KW	KW	COP	KW	KW	COP	KW	KW	COP	KW	KW	COP
5.0	1445.2	333.3	3.9	1421.6	382.4	3.4	1394.8	438.5	2.9	1355.8	500.1	2.5	1315.0	546.5	2.3	1035.8	456.3	2.1
6.0	1486.4	335.6	4.0	1461.7	383.8	3.5	1433.6	439.6	3.0	1390.7	500.4	2.6	1346.5	546.7	2.3	1045.4	446.4	2.2
7.0	1528.4	338.3	4.1	1502.7	385.6	3.6	1473.3	440.8	3.1	1426.6	500.6	2.7	1378.7	546.6	2.4	1055.6	437.2	2.2
8.0	1571.4	341.5	4.2	1544.5	387.6	3.6	1513.8	442.4	3.2	1463.3	500.8	2.7	1411.5	546.4	2.4	1065.8	427.9	2.3
9.0	1615.2	345.1	4.2	1587.3	390.0	3.7	1555.2	444.1	3.2	1500.7	501.0	2.8	1445.0	545.9	2.5	1075.9	418.8	2.4
10.0	1659.8	349.0	4.3	1630.9	392.8	3.8	1597.6	446.0	3.3	1538.8	501.3	2.9	1479.0	545.3	2.5	1085.7	409.6	2.4
11.0	1705.5	353.5	4.4	1675.3	396.0	3.9	1640.8	448.2	3.4	1577.1	501.5	2.9	1513.8	544.5	2.6	1095.5	400.7	2.5
12.0	1751.9	358.5	4.4	1720.7	399.4	3.9	1684.9	450.7	3.5	1614.2	501.0	3.0	1549.0	543.8	2.7	1105.1	391.8	2.6
13.0	1799.3	364.0	4.5	1767.0	403.3	4.0	1729.7	453.7	3.5	1652.0	500.5	3.1	1573.1	535.9	2.8	1114.5	383.0	2.7

## MODEL: YCAV0477E/V

### AIR TEMPERATURE ON - CONDENSER (°C)

LCWT (°C)	25.0			30.0			35.0			40.0			45.0			50.0		
	KW	KW	COP	KW	KW	COP	KW	KW	COP	KW	KW	COP	KW	KW	COP	KW	KW	COP
5.0	1590.0	373.2	3.9	1562.9	423.8	3.4	1530.9	480.6	2.9	1488.9	545.8	2.5	1459.4	606.6	2.3	1131.3	496.0	2.1
6.0	1635.3	376.3	3.9	1607.4	426.5	3.4	1574.2	483.1	3.0	1529.0	547.6	2.6	1495.9	607.9	2.3	1142.6	485.5	2.2
7.0	1681.5	379.7	4.0	1652.7	429.4	3.5	1618.4	485.7	3.1	1570.1	549.4	2.7	1533.4	609.0	2.4	1153.8	475.1	2.2
8.0	1728.4	383.4	4.1	1699.0	432.5	3.6	1663.4	488.7	3.1	1611.9	551.3	2.7	1571.6	610.1	2.4	1164.9	464.8	2.3
9.0	1776.2	387.5	4.2	1746.0	436.0	3.7	1709.5	491.6	3.2	1654.7	553.3	2.8	1610.6	611.1	2.5	1175.7	454.6	2.4
10.0	1825.0	391.8	4.2	1794.0	439.7	3.7	1756.3	494.9	3.3	1698.2	555.3	2.9	1650.3	612.2	2.5	1186.2	444.5	2.5
11.0	1874.2	396.4	4.3	1842.8	443.5	3.8	1804.0	498.4	3.4	1742.0	557.4	2.9	1681.8	607.4	2.6	1196.8	434.7	2.5
12.0	1923.6	401.4	4.4	1892.0	447.8	3.9	1852.7	502.0	3.4	1784.7	558.6	3.0	1696.2	591.9	2.7	1207.4	425.0	2.6
13.0	1974.3	405.6	4.4	1941.6	452.2	3.9	1901.7	506.0	3.5	1828.1	560.0	3.1	1709.4	576.3	2.8	1217.6	415.5	2.7

#### NOTES:

1. kW<sub>o</sub> = Unit kW Cooling Capacity Output
2. kW<sub>i</sub> = Compressor kW Input
3. COP = Coefficient of Performance (includes condenser fan power)
4. LCWT = Leaving Chilled Water Temperature
5. Ratings based on 0.15 L/s cooler water per ton, and 0.018 (m<sup>2</sup> - °C)/kW

**NOTES:**

1. kW<sub>o</sub> = Unit kW Cooling Capacity Output
2. kW<sub>i</sub> = Compressor kW Input
3. COP = Coefficient of Performance (includes condenser fan power)
4. LCWT = Leaving Chilled Water Temperature
5. Ratings based on 0.15 L/s cooler water per ton, and 0.018 (m<sup>2</sup> – °C)/kW

# Standard Efficiency Ratings - SI - 50Hz

## MODEL: YCAV0569S/P

### AIR TEMPERATURE ON - CONDENSER (°C)

LCWT (°C)	25.0			30.0			35.0			40.0			45.0			50.0		
	KW	KW	COP	KW	KW	COP	KW	KW	COP	KW	KW	COP	KW	KW	COP	KW	KW	COP
5.0	528.8	135.9	3.5	520.9	155.3	3.1	511.8	176.4	2.7	497.4	200.1	2.3	478.0	225.1	2.0	375.1	189.3	1.9
6.0	543.2	136.7	3.6	535.0	156.1	3.2	525.5	177.2	2.8	509.5	200.8	2.4	489.2	225.8	2.0	378.9	185.3	1.9
7.0	557.9	137.6	3.7	549.4	156.9	3.2	539.5	178.1	2.8	521.7	201.4	2.4	500.4	226.8	2.1	383.1	181.6	2.0
8.0	572.9	138.6	3.8	564.1	157.8	3.3	553.7	179.0	2.9	533.9	202.0	2.5	512.1	227.5	2.1	387.2	177.9	2.0
9.0	588.0	139.6	3.8	578.9	158.7	3.4	568.2	179.9	2.9	546.3	202.6	2.5	524.0	228.2	2.2	391.2	174.2	2.1
10.0	603.4	140.8	3.9	594.1	159.7	3.4	583.0	180.9	3.0	558.9	203.2	2.6	535.8	228.9	2.2	395.2	170.6	2.2
11.0	619.1	141.9	4.0	609.5	160.8	3.5	598.0	182.0	3.1	571.6	203.8	2.6	547.9	229.6	2.3	399.2	167.0	2.2
12.0	635.0	143.2	4.1	625.1	161.9	3.6	613.2	183.1	3.1	584.5	204.4	2.7	560.1	230.2	2.3	403.0	163.5	2.3
13.0	651.2	144.5	4.1	641.0	163.1	3.6	628.7	184.2	3.2	597.5	205.1	2.7	572.5	230.9	2.3	406.8	160.0	2.3

## MODEL: YCAV0639S/P

### AIR TEMPERATURE ON - CONDENSER (°C)

LCWT (°C)	25.0			30.0			35.0			40.0			45.0			50.0		
	KW	KW	COP	KW	KW	COP	KW	KW	COP	KW	KW	COP	KW	KW	COP	KW	KW	COP
5.0	587.3	149.5	3.6	576.4	171.3	3.1	563.2	194.8	2.7	536.0	213.2	2.4	496.0	220.3	2.1	346.9	156.8	2.0
6.0	603.7	150.6	3.7	592.6	172.3	3.2	579.1	195.9	2.8	550.1	213.8	2.4	501.5	216.2	2.2	350.7	153.4	2.1
7.0	620.4	151.6	3.8	609.2	173.3	3.3	595.2	197.0	2.8	563.9	214.3	2.5	507.6	212.3	2.3	354.5	150.1	2.2
8.0	637.4	152.7	3.8	626.0	174.4	3.3	611.2	197.8	2.9	577.7	214.6	2.5	514.0	208.4	2.3	358.1	146.9	2.2
9.0	654.7	153.9	3.9	643.0	175.5	3.4	626.8	198.3	3.0	591.8	215.0	2.6	519.6	204.2	2.4	361.7	143.7	2.3
10.0	672.0	155.1	4.0	660.4	176.6	3.5	642.6	198.8	3.0	605.9	215.4	2.7	524.9	199.9	2.5	365.1	140.6	2.4
11.0	689.4	156.6	4.1	677.8	177.9	3.5	658.6	199.3	3.1	620.3	215.7	2.7	529.6	195.6	2.5	368.4	137.5	2.4
12.0	707.1	158.1	4.1	695.4	179.2	3.6	674.7	199.8	3.2	634.8	216.0	2.8	534.0	191.4	2.6	371.7	134.5	2.5
13.0	725.1	159.6	4.2	713.3	180.6	3.7	691.0	200.4	3.2	649.5	216.3	2.8	538.1	187.3	2.7	374.7	131.6	2.6

## MODEL: YCAV0679S/P

### AIR TEMPERATURE ON - CONDENSER (°C)

LCWT (°C)	25.0			30.0			35.0			40.0			45.0			50.0		
	KW	KW	COP	KW	KW	COP	KW	KW	COP	KW	KW	COP	KW	KW	COP	KW	KW	COP
5.0	639.4	161.3	3.6	628.8	184.3	3.2	616.7	209.4	2.8	594.6	234.7	2.4	570.9	257.1	2.1	438.5	206.9	2.0
6.0	657.2	162.5	3.7	646.3	185.3	3.2	633.7	210.4	2.8	608.9	235.1	2.4	584.4	257.7	2.1	442.7	202.4	2.0
7.0	675.3	163.7	3.8	664.0	186.4	3.3	651.0	211.6	2.9	623.5	235.5	2.5	598.1	258.2	2.2	447.1	198.1	2.1
8.0	693.7	165.1	3.9	682.0	187.6	3.4	668.4	212.8	2.9	638.4	235.8	2.5	612.0	258.7	2.2	451.3	193.8	2.2
9.0	712.5	166.6	3.9	700.4	188.9	3.4	686.2	214.0	3.0	653.5	236.2	2.6	626.2	259.1	2.3	455.6	189.6	2.2
10.0	731.6	168.1	4.0	719.0	190.3	3.5	704.3	215.3	3.1	668.7	236.6	2.7	640.6	259.5	2.3	459.7	185.3	2.3
11.0	751.0	169.7	4.1	738.0	191.7	3.6	722.8	216.7	3.1	683.9	237.0	2.7	653.4	258.4	2.4	463.8	181.2	2.4
12.0	770.7	171.5	4.1	757.3	193.3	3.6	741.6	218.1	3.2	699.5	237.4	2.8	658.8	251.8	2.5	467.9	177.2	2.4
13.0	790.7	173.4	4.2	776.9	194.9	3.7	760.7	219.7	3.2	715.3	237.8	2.8	664.8	245.5	2.6	471.9	173.1	2.5

#### NOTES:

1. kW<sub>o</sub> = Unit kW Cooling Capacity Output
2. kW<sub>i</sub> = Compressor kW Input
3. COP = Coefficient of Performance (includes condenser fan power)
4. LCWT = Leaving Chilled Water Temperature
5. Ratings based on 0.15 L/s cooler water per ton, and 0.018 (m<sup>2</sup> - °C)/kW

**MODEL: YCAV0739S/P**

## AIR TEMPERATURE ON - CONDENSER (°C)

LCWT (°C)	25.0			30.0			35.0			40.0			45.0			50.0		
	KW	KW	COP	KW	KW	COP	KW	KW	COP	KW	KW	COP	KW	KW	COP	KW	KW	COP
5.0	689.5	174.1	3.6	676.6	200.8	3.1	662.1	230.6	2.7	629.2	253.3	2.3	569.3	248.9	2.2	396.8	175.6	2.1
6.0	709.0	175.2	3.7	695.5	201.6	3.2	680.0	231.2	2.8	644.2	253.1	2.4	574.7	243.5	2.2	402.2	174.8	2.1
7.0	728.8	176.5	3.8	714.8	202.5	3.3	697.4	231.3	2.8	659.6	252.8	2.5	581.3	238.6	2.3	405.5	168.1	2.2
8.0	749.1	178.0	3.9	734.4	203.5	3.4	715.2	231.5	2.9	675.3	252.5	2.5	587.4	233.3	2.4	409.7	164.5	2.3
9.0	769.7	179.7	4.0	754.5	204.7	3.4	733.3	231.7	3.0	691.2	252.1	2.6	593.4	228.2	2.4	413.8	161.0	2.4
10.0	790.7	181.7	4.0	774.9	206.1	3.5	751.7	232.0	3.0	707.2	251.7	2.7	599.0	223.2	2.5	417.7	157.5	2.4
11.0	812.1	183.9	4.1	795.7	207.7	3.6	770.3	232.4	3.1	723.6	251.3	2.7	604.1	218.5	2.6	421.5	154.1	2.5
12.0	834.0	186.3	4.1	816.9	209.4	3.6	789.3	232.9	3.2	740.2	250.9	2.8	609.1	213.8	2.7	425.3	150.8	2.6
13.0	856.2	188.9	4.2	838.5	211.4	3.7	808.6	233.6	3.3	757.1	250.6	2.9	614.0	209.2	2.7	428.8	147.5	2.6

**MODEL: YCAV0819S/P**

## AIR TEMPERATURE ON - CONDENSER (°C)

LCWT (°C)	25.0			30.0			35.0			40.0			45.0			50.0		
	KW	KW	COP	KW	KW	COP	KW	KW	COP	KW	KW	COP	KW	KW	COP	KW	KW	COP
5.0	748.4	186.3	3.7	735.1	212.7	3.2	720.1	241.8	2.8	690.4	268.3	2.4	663.0	287.9	2.2	505.5	228.6	2.1
6.0	769.6	187.7	3.8	755.7	214.0	3.3	739.9	243.0	2.9	707.1	268.5	2.5	678.6	288.3	2.2	509.9	223.6	2.1
7.0	791.1	189.3	3.8	776.7	215.3	3.4	760.1	244.5	2.9	724.0	268.6	2.5	694.5	288.5	2.3	514.9	219.0	2.2
8.0	813.1	191.0	3.9	798.1	216.8	3.4	780.9	245.9	3.0	741.2	268.7	2.6	710.7	288.7	2.3	519.8	214.3	2.3
9.0	835.5	192.8	4.0	819.9	218.4	3.5	802.0	247.4	3.0	758.8	268.7	2.7	727.1	288.9	2.4	524.7	209.6	2.3
10.0	858.4	194.8	4.1	842.2	220.1	3.6	823.6	248.9	3.1	776.3	268.8	2.7	743.9	288.9	2.4	529.5	205.0	2.4
11.0	881.7	196.9	4.1	864.9	221.9	3.6	845.6	250.6	3.2	794.4	268.9	2.8	751.4	283.0	2.5	534.3	200.5	2.5
12.0	905.3	199.2	4.2	888.1	223.9	3.7	867.9	252.5	3.2	812.7	269.0	2.8	758.2	276.3	2.6	539.0	196.0	2.5
13.0	929.1	201.6	4.3	911.5	225.9	3.8	890.8	254.3	3.3	831.3	269.1	2.9	765.1	269.4	2.7	543.6	191.5	2.6

**MODEL: YCAV0889S/P**

## AIR TEMPERATURE ON - CONDENSER (°C)

LCWT (°C)	25.0			30.0			35.0			40.0			45.0			50.0		
	KW	KW	COP	KW	KW	COP	KW	KW	COP	KW	KW	COP	KW	KW	COP	KW	KW	COP
5.0	821.2	205.3	3.7	807.2	233.7	3.2	791.2	265.0	2.8	762.5	295.6	2.4	742.6	323.7	2.2	553.3	248.0	2.1
6.0	844.2	206.9	3.8	829.7	235.2	3.3	812.9	266.5	2.9	781.4	296.3	2.5	760.5	324.5	2.2	558.8	242.7	2.1
7.0	867.7	208.7	3.8	852.5	236.9	3.3	834.9	268.3	2.9	800.6	296.9	2.5	778.7	325.3	2.3	564.1	237.5	2.2
8.0	891.5	210.6	3.9	875.8	238.6	3.4	857.5	270.0	3.0	820.1	297.5	2.6	797.2	326.1	2.3	569.5	232.2	2.3
9.0	915.8	212.6	4.0	899.5	240.5	3.5	880.5	271.8	3.0	839.9	298.1	2.7	805.0	319.3	2.4	574.8	227.1	2.3
10.0	940.5	214.7	4.0	923.7	242.4	3.5	904.0	273.6	3.1	859.8	298.7	2.7	812.7	312.2	2.5	579.9	222.0	2.4
11.0	965.7	217.0	4.1	948.2	244.5	3.6	927.8	275.6	3.2	880.3	299.3	2.8	820.1	304.6	2.5	585.1	217.1	2.5
12.0	991.2	219.5	4.2	973.3	246.7	3.7	952.1	277.6	3.2	901.1	300.0	2.8	826.9	296.9	2.6	590.4	212.3	2.6
13.0	1017.2	221.4	4.2	998.6	248.9	3.7	976.9	279.8	3.3	922.2	300.7	2.9	833.1	289.1	2.7	595.3	207.5	2.6

**NOTES:**

1. kW<sub>o</sub> = Unit kW Cooling Capacity Output
2. kW<sub>i</sub> = Compressor kW Input
3. COP = Coefficient of Performance (includes condenser fan power)
4. LCWT = Leaving Chilled Water Temperature
5. Ratings based on 0.15 L/s cooler water per ton, and 0.018 (m<sup>2</sup> - °C)/kW

# Standard Efficiency Ratings - SI - 50Hz - continued

## MODEL: YCAV0969S/P

### AIR TEMPERATURE ON - CONDENSER (°C)

LCWT (°C)	25.0			30.0			35.0			40.0			45.0			50.0		
	KW	KW	COP	KW	KW	COP	KW	KW	COP	KW	KW	COP	KW	KW	COP	KW	KW	COP
5.0	894.3	224.1	3.7	879.6	254.5	3.2	862.6	287.9	2.8	834.9	322.6	2.4	822.5	359.0	2.2	617.9	276.6	2.1
6.0	919.1	225.9	3.7	903.8	256.3	3.3	886.1	289.8	2.9	856.0	323.7	2.5	842.6	360.4	2.2	623.9	270.6	2.2
7.0	944.5	227.9	3.8	928.6	258.2	3.3	909.9	291.8	2.9	877.4	324.8	2.5	863.1	361.7	2.3	629.9	264.7	2.2
8.0	970.2	230.0	3.9	953.7	260.2	3.4	934.4	293.8	3.0	899.1	325.9	2.6	884.1	363.0	2.3	635.8	258.9	2.3
9.0	996.3	232.2	4.0	979.4	262.3	3.5	959.2	295.9	3.0	921.3	327.0	2.7	892.1	354.8	2.4	641.5	253.1	2.4
10.0	1023.0	234.5	4.0	1005.4	264.4	3.5	984.6	298.0	3.1	943.6	328.3	2.7	900.3	346.3	2.5	647.2	247.5	2.4
11.0	1050.0	236.9	4.1	1031.8	266.8	3.6	1010.4	300.2	3.2	966.5	329.4	2.8	908.4	337.8	2.5	652.8	242.0	2.5
12.0	1077.5	239.6	4.2	1058.8	269.2	3.7	1036.6	302.5	3.2	989.7	330.6	2.8	916.3	329.6	2.6	658.4	236.6	2.6
13.0	1105.6	241.0	4.2	1086.0	271.7	3.7	1063.2	305.0	3.3	1013.3	331.9	2.9	923.9	321.6	2.7	663.5	231.2	2.6

## MODEL: YCAV1039S/P

### AIR TEMPERATURE ON - CONDENSER (°C)

LCWT (°C)	25.0			30.0			35.0			40.0			45.0			50.0		
	KW	KW	COP	KW	KW	COP	KW	KW	COP	KW	KW	COP	KW	KW	COP	KW	KW	COP
5.0	949.5	235.7	3.7	932.1	270.9	3.2	911.8	309.3	2.8	873.5	343.0	2.4	798.6	346.4	2.2	557.0	246.8	2.1
6.0	976.3	237.2	3.8	958.3	272.2	3.3	937.2	310.6	2.8	895.5	343.5	2.5	807.5	340.1	2.2	563.2	241.6	2.1
7.0	1003.6	238.8	3.9	985.0	273.5	3.3	962.8	311.8	2.9	917.2	343.8	2.5	816.1	333.3	2.3	569.4	236.4	2.2
8.0	1031.4	240.6	3.9	1012.3	275.0	3.4	988.1	312.5	3.0	939.4	343.9	2.6	826.2	327.1	2.4	575.4	231.4	2.3
9.0	1059.7	242.7	4.0	1040.1	276.6	3.5	1013.9	313.3	3.0	962.0	344.1	2.6	835.4	320.5	2.4	581.2	226.4	2.3
10.0	1088.5	244.9	4.1	1068.4	278.3	3.6	1040.2	314.2	3.1	985.0	344.1	2.7	844.1	313.9	2.5	586.9	221.6	2.4
11.0	1117.8	247.5	4.2	1097.2	280.3	3.6	1066.9	315.2	3.2	1008.2	344.2	2.8	852.1	307.3	2.6	592.3	216.8	2.5
12.0	1147.6	250.2	4.2	1126.5	282.5	3.7	1094.0	316.2	3.2	1031.7	344.3	2.8	859.3	300.8	2.7	597.6	212.1	2.6
13.0	1177.9	253.1	4.3	1156.3	284.9	3.8	1121.6	317.4	3.3	1055.6	344.5	2.9	866.2	294.4	2.7	602.7	207.6	2.6

## MODEL: YCAV1139S/P

### AIR TEMPERATURE ON - CONDENSER (°C)

LCWT (°C)	25.0			30.0			35.0			40.0			45.0			50.0		
	KW	KW	COP	KW	KW	COP	KW	KW	COP	KW	KW	COP	KW	KW	COP	KW	KW	COP
5.0	1055.2	260.0	3.7	1036.1	300.0	3.2	1014.7	344.4	2.8	970.6	382.0	2.4	876.1	374.5	2.2	609.6	264.1	2.1
6.0	1084.9	261.7	3.8	1064.9	301.1	3.3	1042.0	345.2	2.8	993.7	381.8	2.5	884.3	366.4	2.3	616.5	258.5	2.2
7.0	1115.3	263.6	3.9	1094.4	302.4	3.4	1069.2	345.6	2.9	1017.4	381.4	2.5	893.8	358.6	2.3	623.2	252.9	2.3
8.0	1146.3	265.7	4.0	1124.5	303.8	3.4	1097.1	346.1	3.0	1041.6	380.9	2.6	904.1	351.2	2.4	629.7	247.5	2.3
9.0	1178.0	268.2	4.0	1155.3	305.5	3.5	1125.4	346.8	3.0	1066.2	380.3	2.6	913.5	343.6	2.5	636.0	242.2	2.4
10.0	1210.2	271.0	4.1	1186.6	307.5	3.6	1154.3	347.5	3.1	1091.1	379.7	2.7	922.5	336.1	2.6	642.1	237.0	2.5
11.0	1243.0	274.2	4.2	1218.5	309.9	3.7	1183.7	348.4	3.2	1116.3	379.2	2.8	930.5	329.0	2.6	648.0	231.9	2.5
12.0	1276.6	277.7	4.2	1251.1	312.4	3.7	1213.7	349.5	3.3	1142.1	378.6	2.8	938.4	322.0	2.7	653.8	226.9	2.6
13.0	1310.6	281.6	4.3	1284.3	315.2	3.8	1244.1	350.9	3.3	1168.3	378.1	2.9	945.9	315.2	2.8	659.3	222.1	2.7

### NOTES:

1. kW<sub>o</sub> = Unit kW Cooling Capacity Output
2. kW<sub>i</sub> = Compressor kW Input
3. COP = Coefficient of Performance (includes condenser fan power)
4. LCWT = Leaving Chilled Water Temperature
5. Ratings based on 0.15 L/s cooler water per ton, and 0.018 (m<sup>2</sup> - °C)/kW

**MODEL: YCAV1309S/P**

## AIR TEMPERATURE ON - CONDENSER (°C)

LCWT (°C)	25.0			30.0			35.0			40.0			45.0			50.0		
	KW	KW	COP	KW	KW	COP	KW	KW	COP	KW	KW	COP	KW	KW	COP	KW	KW	COP
5.0	1191.3	297.4	3.7	1170.8	339.2	3.2	1147.5	384.9	2.8	1105.5	429.4	2.4	1072.3	467.1	2.2	801.6	360.6	2.1
6.0	1224.9	299.8	3.8	1203.5	341.3	3.3	1179.0	387.1	2.9	1132.5	430.1	2.5	1097.9	468.2	2.2	809.4	353.0	2.1
7.0	1259.1	302.2	3.8	1236.8	343.5	3.3	1211.2	389.4	2.9	1160.1	430.8	2.5	1123.9	469.1	2.3	817.4	345.4	2.2
8.0	1294.0	304.8	3.9	1270.8	345.9	3.4	1244.0	391.8	3.0	1188.2	431.4	2.6	1150.5	470.0	2.3	825.3	337.9	2.3
9.0	1329.5	307.8	4.0	1305.4	348.5	3.5	1277.5	394.4	3.0	1216.8	432.1	2.7	1169.3	465.5	2.4	832.9	330.5	2.3
10.0	1365.7	310.8	4.0	1340.7	351.3	3.6	1311.7	396.9	3.1	1245.7	432.7	2.7	1180.3	455.5	2.5	840.5	323.2	2.4
11.0	1402.6	314.0	4.1	1376.7	354.1	3.6	1346.7	399.6	3.2	1275.0	433.4	2.8	1191.4	445.0	2.5	848.1	316.0	2.5
12.0	1439.8	317.6	4.2	1413.4	357.2	3.7	1382.2	402.6	3.2	1305.0	434.1	2.8	1201.5	433.8	2.6	855.8	309.0	2.6
13.0	1477.6	321.0	4.3	1450.3	360.4	3.7	1418.5	405.6	3.3	1335.5	434.8	2.9	1210.6	422.2	2.7	863.4	302.1	2.6

**MODEL: YCAV1429S/P**

## AIR TEMPERATURE ON - CONDENSER (°C)

LCWT (°C)	25.0			30.0			35.0			40.0			45.0			50.0		
	KW	KW	COP	KW	KW	COP	KW	KW	COP	KW	KW	COP	KW	KW	COP	KW	KW	COP
5.0	1337.3	335.1	3.7	1315.3	380.8	3.2	1289.8	430.8	2.8	1249.5	483.0	2.4	1231.2	537.6	2.2	930.4	418.5	2.1
6.0	1374.7	337.8	3.7	1351.8	383.4	3.3	1325.2	433.5	2.9	1280.8	484.8	2.5	1261.2	539.7	2.2	939.6	409.5	2.1
7.0	1412.9	340.6	3.8	1389.0	386.1	3.3	1361.1	436.5	2.9	1312.9	486.5	2.5	1291.9	541.7	2.3	948.6	400.6	2.2
8.0	1451.9	343.7	3.9	1426.9	389.2	3.4	1397.9	439.5	3.0	1345.7	488.2	2.6	1323.3	543.7	2.3	957.6	391.8	2.3
9.0	1491.4	347.1	4.0	1465.7	392.3	3.5	1435.3	442.7	3.0	1379.2	489.9	2.7	1344.8	538.0	2.4	966.4	383.2	2.3
10.0	1531.8	350.5	4.0	1505.1	395.5	3.5	1473.6	445.8	3.1	1412.8	491.7	2.7	1355.8	524.7	2.4	975.0	374.6	2.4
11.0	1572.9	354.1	4.1	1545.3	398.8	3.6	1512.7	449.1	3.2	1447.4	493.5	2.8	1368.1	512.0	2.5	983.5	366.3	2.5
12.0	1613.6	357.9	4.2	1586.1	402.5	3.7	1552.4	452.5	3.2	1482.4	495.3	2.8	1380.2	499.5	2.6	991.8	358.0	2.6
13.0	0.0	0.0	0.0	1626.5	406.1	3.7	1593.0	456.1	3.3	1518.1	497.1	2.9	1391.8	487.3	2.7	999.8	350.0	2.6

**MODEL: YCAV1549S/P**

## AIR TEMPERATURE ON - CONDENSER (°C)

LCWT (°C)	25.0			30.0			35.0			40.0			45.0			50.0		
	KW	KW	COP	KW	KW	COP	KW	KW	COP	KW	KW	COP	KW	KW	COP	KW	KW	COP
5.0	1421.9	355.6	3.7	1399.6	408.9	3.2	1374.2	467.3	2.7	1329.7	525.5	2.4	1280.0	563.9	2.1	1008.9	466.4	2.0
6.0	1460.7	357.8	3.7	1437.4	410.5	3.2	1411.0	469.1	2.8	1361.9	525.6	2.4	1310.0	564.8	2.2	1019.2	456.6	2.1
7.0	1500.2	360.2	3.8	1475.9	412.3	3.3	1448.3	470.8	2.9	1394.3	525.6	2.5	1340.7	565.4	2.2	1028.3	446.7	2.1
8.0	1540.4	362.7	3.9	1515.1	414.3	3.4	1486.3	472.7	2.9	1426.7	525.4	2.6	1372.1	565.8	2.3	1038.3	437.3	2.2
9.0	1581.3	365.6	4.0	1555.0	416.6	3.5	1524.9	474.9	3.0	1459.6	525.2	2.6	1404.0	566.0	2.3	1048.3	427.9	2.3
10.0	1622.8	368.9	4.0	1595.7	419.0	3.5	1564.3	477.1	3.1	1493.0	524.9	2.7	1435.3	566.1	2.4	1058.2	418.6	2.3
11.0	1665.1	372.3	4.1	1637.0	421.8	3.6	1604.4	479.4	3.1	1526.9	524.5	2.7	1467.4	566.0	2.5	1067.9	409.3	2.4
12.0	1708.0	376.1	4.2	1678.8	424.9	3.7	1645.2	481.9	3.2	1560.9	524.3	2.8	1500.0	565.7	2.5	1077.5	400.3	2.5
13.0	1751.7	380.1	4.2	1721.5	428.2	3.7	1686.7	484.6	3.3	1595.7	524.0	2.9	1522.4	558.2	2.6	1087.1	391.3	2.6

**NOTES:**

1. kW<sub>o</sub> = Unit kW Cooling Capacity Output
2. kW<sub>i</sub> = Compressor kW Input
3. COP = Coefficient of Performance (includes condenser fan power)
4. LCWT = Leaving Chilled Water Temperature
5. Ratings based on 0.15 L/s cooler water per ton, and 0.018 (m<sup>2</sup> - °C)/kW

# Standard Efficiency Ratings - SI - 50Hz - continued

## MODEL: YCAV1649S/P

### AIR TEMPERATURE ON - CONDENSER (°C)

LCWT (°C)	25.0			30.0			35.0			40.0			45.0			50.0		
	KW	KW	COP	KW	KW	COP	KW	KW	COP	KW	KW	COP	KW	KW	COP	KW	KW	COP
5.0	1521.5	389.5	3.6	1495.7	444.2	3.1	1465.6	504.4	2.7	1418.8	566.0	2.4	1332.8	585.7	2.2	931.5	409.2	2.1
6.0	1563.0	392.3	3.7	1536.3	446.8	3.2	1505.5	507.1	2.8	1453.9	567.2	2.4	1346.3	573.8	2.2	942.0	400.7	2.2
7.0	1605.2	395.4	3.7	1577.6	449.7	3.3	1545.7	509.9	2.8	1489.5	568.4	2.5	1358.2	560.8	2.3	951.3	391.7	2.2
8.0	1648.1	398.6	3.8	1619.7	452.6	3.3	1586.6	512.8	2.9	1525.7	569.5	2.5	1368.0	546.3	2.4	961.3	383.4	2.3
9.0	1691.7	402.2	3.9	1662.5	455.8	3.4	1628.2	515.8	3.0	1562.2	570.6	2.6	1378.8	532.6	2.4	970.9	375.0	2.4
10.0	1735.9	405.9	3.9	1705.9	459.1	3.5	1669.7	518.7	3.0	1599.3	571.6	2.6	1389.7	519.5	2.5	980.3	366.9	2.4
11.0	1780.8	409.9	4.0	1750.0	462.7	3.5	1712.0	521.5	3.1	1636.9	572.7	2.7	1400.9	507.3	2.6	989.2	358.7	2.5
12.0	1826.3	414.1	4.1	1794.7	466.5	3.6	1754.9	524.5	3.1	1674.7	574.0	2.8	1412.4	495.9	2.7	997.6	350.9	2.6
13.0	1872.5	418.5	4.1	1840.1	470.5	3.6	1798.3	527.7	3.2	1713.2	575.2	2.8	1423.8	484.9	2.7	1006.0	343.1	2.7

## MODEL: YCAV1739S/P

### AIR TEMPERATURE ON - CONDENSER (°C)

LCWT (°C)	25.0			30.0			35.0			40.0			45.0			50.0		
	KW	KW	COP	KW	KW	COP	KW	KW	COP	KW	KW	COP	KW	KW	COP	KW	KW	COP
5.0	1635.6	409.2	3.7	1607.9	466.2	3.2	1576.2	528.7	2.8	1521.2	590.6	2.4	1482.1	646.6	2.2	1111.6	500.2	2.1
6.0	1681.6	412.4	3.7	1652.7	469.2	3.3	1619.5	531.7	2.9	1558.7	592.0	2.5	1517.6	648.4	2.2	1122.5	489.6	2.1
7.0	1728.6	415.8	3.8	1698.5	472.3	3.3	1663.7	535.0	2.9	1596.9	593.2	2.5	1553.9	650.0	2.3	1133.5	479.0	2.2
8.0	1776.5	419.5	3.9	1745.1	475.8	3.4	1708.8	538.5	3.0	1635.9	594.4	2.6	1590.9	651.5	2.3	1144.3	468.5	2.3
9.0	1825.2	423.5	4.0	1792.7	479.3	3.5	1754.8	542.1	3.0	1675.6	595.6	2.7	1617.2	645.3	2.4	1154.9	458.3	2.3
10.0	1874.3	427.6	4.0	1841.1	483.2	3.5	1801.8	545.7	3.1	1715.8	596.9	2.7	1631.9	630.8	2.4	1165.4	448.1	2.4
11.0	1923.9	432.0	4.1	1889.8	487.1	3.6	1849.8	549.5	3.2	1756.7	598.2	2.8	1647.1	616.0	2.5	1175.9	438.1	2.5
12.0	1974.2	436.8	4.2	1939.1	491.4	3.7	1897.8	553.5	3.2	1798.4	599.4	2.8	1661.3	600.6	2.6	1186.3	428.3	2.6
13.0	2025.6	441.5	4.2	1989.2	495.8	3.7	1946.6	557.6	3.3	1840.8	600.8	2.9	1674.4	584.9	2.7	1196.6	418.7	2.6

#### NOTES:

1. kW<sub>o</sub> = Unit kW Cooling Capacity Output
2. kW<sub>i</sub> = Compressor kW Input
3. COP = Coefficient of Performance (includes condenser fan power)
4. LCWT = Leaving Chilled Water Temperature
5. Ratings based on 0.15 L/s cooler water per ton, and 0.018 (m<sup>2</sup> - °C)/kW



**MODEL: YCAV1829S/P**

## AIR TEMPERATURE ON - CONDENSER (°C)

LCWT (°C)	25.0			30.0			35.0			40.0			45.0			50.0		
	KW	KW	COP	KW	KW	COP	KW	KW	COP	KW	KW	COP	KW	KW	COP	KW	KW	COP
5.0	1708.2	427.8	3.7	1679.7	486.9	3.2	1647.0	551.5	2.8	1593.0	617.4	2.4	1561.4	681.8	2.2	1176.0	529.0	2.1
6.0	1756.1	431.4	3.7	1726.5	490.1	3.3	1692.2	554.9	2.9	1632.6	619.3	2.5	1599.1	684.1	2.2	1187.6	517.7	2.1
7.0	1805.1	435.0	3.8	1774.2	493.6	3.3	1738.3	558.5	2.9	1673.2	621.0	2.5	1637.7	686.2	2.3	1199.1	506.5	2.2
8.0	1855.0	438.8	3.9	1822.8	497.4	3.4	1785.4	562.2	3.0	1714.5	622.7	2.6	1677.1	688.3	2.3	1210.5	495.4	2.3
9.0	1905.7	443.1	4.0	1872.4	501.1	3.5	1833.3	566.2	3.0	1756.5	624.4	2.7	1704.8	681.6	2.4	1221.7	484.5	2.3
10.0	1956.6	447.4	4.0	1922.9	505.2	3.5	1882.4	570.1	3.1	1799.1	626.3	2.7	1719.6	665.4	2.4	1232.7	473.7	2.4
11.0	2007.8	451.9	4.1	1973.3	509.3	3.6	1932.4	574.1	3.2	1842.6	628.1	2.8	1735.4	649.5	2.5	1243.5	463.2	2.5
12.0	2059.7	456.8	4.2	2024.1	513.9	3.7	1982.1	578.4	3.2	1886.8	629.9	2.8	1750.5	633.4	2.6	1254.3	452.8	2.6
13.0	2112.8	461.4	4.2	2075.9	518.4	3.7	2032.5	582.7	3.3	1931.8	631.9	2.9	1764.9	617.5	2.7	1264.8	442.7	2.6

**MODEL: YCAV1909S/P**

## AIR TEMPERATURE ON - CONDENSER (°C)

LCWT (°C)	25.0			30.0			35.0			40.0			45.0			50.0		
	KW	KW	COP	KW	KW	COP	KW	KW	COP	KW	KW	COP	KW	KW	COP	KW	KW	COP
5.0	1780.9	446.4	3.7	1751.7	507.5	3.2	1718.0	574.3	2.8	1665.0	644.0	2.4	1640.7	716.8	2.2	1240.7	557.8	2.1
6.0	1830.8	450.2	3.7	1800.4	511.0	3.3	1765.1	577.9	2.9	1706.7	646.4	2.5	1680.7	719.5	2.2	1252.9	545.9	2.1
7.0	1881.8	454.0	3.8	1850.1	514.7	3.3	1813.1	581.9	2.9	1749.5	648.6	2.5	1721.7	722.2	2.3	1265.0	534.0	2.2
8.0	1933.7	458.1	3.9	1900.6	518.8	3.4	1862.1	585.8	3.0	1793.2	650.8	2.6	1763.5	724.8	2.3	1277.0	522.3	2.3
9.0	1986.4	462.6	4.0	1952.3	522.9	3.5	1912.1	590.1	3.0	1837.6	653.1	2.7	1792.8	717.7	2.4	1288.7	510.7	2.3
10.0	2039.1	467.0	4.0	2004.9	527.1	3.5	1963.1	594.3	3.1	1882.6	655.6	2.7	1807.5	699.9	2.4	1300.1	499.3	2.4
11.0	2091.9	471.6	4.1	2056.9	531.5	3.6	2015.2	598.7	3.2	1928.6	657.9	2.8	1823.9	682.9	2.5	1311.5	488.2	2.5
12.0	2145.4	476.7	4.2	2109.3	536.2	3.7	2066.6	603.1	3.2	1975.4	660.3	2.8	1840.1	666.2	2.6	1322.6	477.2	2.6
13.0	2200.1	481.3	4.2	2162.6	541.0	3.7	2118.6	607.7	3.3	2023.0	662.8	2.9	1855.6	650.0	2.7	1333.2	466.5	2.6

**NOTES:**

1. kW<sub>o</sub> = Unit kW Cooling Capacity Output
2. kW<sub>i</sub> = Compressor kW Input
3. COP = Coefficient of Performance (includes condenser fan power)
4. LCWT = Leaving Chilled Water Temperature
5. Ratings based on 0.15 L/s cooler water per ton, and 0.018 (m<sup>2</sup> - °C)/kW

# High Efficiency Ratings - SI - 50Hz

## MODEL: YCAV0569E/V

### AIR TEMPERATURE ON - CONDENSER (°C)

LCWT (°C)	25.0			30.0			35.0			40.0			45.0			50.0		
	KW	KW	COP	KW	KW	COP	KW	KW	COP	KW	KW	COP	KW	KW	COP	KW	KW	COP
5.0	525.0	125.6	3.8	515.6	141.9	3.3	503.3	159.4	2.9	487.8	180.0	2.5	464.9	201.9	2.2	379.5	184.8	1.9
6.0	539.7	126.6	3.9	530.4	143.0	3.4	518.1	160.6	3.0	500.9	180.9	2.6	477.0	202.7	2.2	383.6	181.1	2.0
7.0	554.7	127.6	3.9	545.4	144.1	3.5	533.0	161.8	3.0	514.0	181.8	2.6	489.2	203.6	2.3	387.7	177.4	2.0
8.0	569.9	128.7	4.0	560.7	145.3	3.5	548.1	163.0	3.1	527.2	182.7	2.7	501.4	204.5	2.3	391.7	173.8	2.1
9.0	585.2	129.7	4.1	576.2	146.4	3.6	563.5	164.2	3.2	540.5	183.7	2.7	514.1	205.5	2.4	395.7	170.2	2.2
10.0	600.7	130.8	4.2	591.8	147.6	3.7	579.1	165.5	3.2	554.0	184.6	2.8	527.1	206.4	2.4	399.6	166.7	2.2
11.0	616.4	131.8	4.2	607.7	148.8	3.8	594.9	166.9	3.3	567.6	185.6	2.9	540.1	207.3	2.5	403.4	163.2	2.3
12.0	632.2	132.9	4.3	623.8	150.0	3.8	610.9	168.2	3.4	581.2	186.6	2.9	553.3	208.3	2.5	407.1	159.7	2.4
13.0	648.3	134.0	4.4	640.1	151.3	3.9	627.2	169.6	3.4	595.0	187.6	3.0	566.7	209.3	2.5	410.9	156.3	2.4

## MODEL: YCAV0639E/V

### AIR TEMPERATURE ON - CONDENSER (°C)

LCWT (°C)	25.0			30.0			35.0			40.0			45.0			50.0		
	KW	KW	COP	KW	KW	COP	KW	KW	COP	KW	KW	COP	KW	KW	COP	KW	KW	COP
5.0	558.7	131.8	3.8	550.3	150.1	3.3	540.3	170.4	2.9	525.1	193.6	2.5	509.7	219.8	2.2	389.5	180.5	2.0
6.0	574.5	132.8	3.9	565.7	150.9	3.4	555.3	171.2	3.0	538.7	194.3	2.6	522.0	220.5	2.2	393.8	176.9	2.1
7.0	590.5	133.8	4.0	581.5	151.8	3.5	570.6	172.1	3.1	552.7	194.9	2.6	534.6	221.1	2.3	398.0	173.3	2.1
8.0	606.9	134.9	4.1	597.5	152.8	3.6	586.3	172.9	3.1	566.8	195.6	2.7	547.4	221.7	2.3	402.1	169.8	2.2
9.0	623.5	136.1	4.1	613.9	153.8	3.6	602.3	173.9	3.2	581.3	196.3	2.8	560.4	222.3	2.4	406.2	166.3	2.2
10.0	640.4	137.4	4.2	630.5	154.9	3.7	618.5	174.9	3.3	596.0	197.1	2.8	573.6	222.8	2.4	410.1	162.9	2.3
11.0	657.7	138.8	4.3	647.5	156.1	3.8	635.1	176.0	3.3	610.9	197.8	2.9	587.1	223.4	2.5	414.0	159.5	2.4
12.0	675.2	140.2	4.4	664.8	157.4	3.9	652.0	177.1	3.4	626.1	198.6	2.9	596.4	220.7	2.5	417.8	156.2	2.4
13.0	693.1	141.8	4.4	682.3	158.7	3.9	669.2	178.3	3.5	641.6	199.5	3.0	602.4	215.6	2.6	421.5	152.8	2.5

## MODEL: YCAV0679E/V

### AIR TEMPERATURE ON - CONDENSER (°C)

LCWT (°C)	25.0			30.0			35.0			40.0			45.0			50.0		
	KW	KW	COP	KW	KW	COP	KW	KW	COP	KW	KW	COP	KW	KW	COP	KW	KW	COP
5.0	621.1	146.3	3.8	611.6	167.4	3.3	600.1	190.8	2.9	582.8	216.0	2.5	566.5	238.4	2.2	448.5	202.5	2.0
6.0	638.5	147.3	3.9	628.9	168.2	3.4	617.0	191.5	3.0	598.1	216.4	2.6	580.5	238.8	2.3	452.8	198.2	2.1
7.0	656.2	148.3	4.0	646.4	169.0	3.5	634.2	192.3	3.0	613.8	216.7	2.6	594.8	239.2	2.3	457.4	194.1	2.2
8.0	674.1	149.4	4.1	664.2	169.9	3.6	651.7	193.2	3.1	629.7	217.0	2.7	609.3	239.6	2.4	461.7	189.9	2.2
9.0	692.3	150.7	4.1	682.2	170.9	3.6	669.4	194.1	3.2	645.8	217.3	2.8	624.1	239.9	2.4	466.0	185.7	2.3
10.0	710.7	152.1	4.2	700.4	172.0	3.7	687.3	195.0	3.2	662.3	217.6	2.8	639.0	240.1	2.5	470.1	181.6	2.4
11.0	729.4	153.5	4.3	719.0	173.2	3.8	705.6	196.1	3.3	678.9	218.0	2.9	654.3	240.4	2.5	474.3	177.6	2.4
12.0	748.4	155.1	4.4	737.8	174.6	3.9	724.1	197.2	3.4	695.7	218.3	3.0	669.8	240.6	2.6	478.3	173.6	2.5
13.0	767.7	156.8	4.4	756.9	176.0	3.9	742.9	198.5	3.5	712.8	218.7	3.0	682.8	239.0	2.7	482.4	169.7	2.6

#### NOTES:

1. kW<sub>o</sub> = Unit kW Cooling Capacity Output
2. kW<sub>i</sub> = Compressor kW Input
3. COP = Coefficient of Performance (includes condenser fan power)
4. LCWT = Leaving Chilled Water Temperature
5. Ratings based on 0.15 L/s cooler water per ton, and 0.018 (m<sup>2</sup> - °C)/kW

**MODEL: YCAV0719E/V**

## AIR TEMPERATURE ON - CONDENSER (°C)

LCWT (°C)	25.0			30.0			35.0			40.0			45.0			50.0		
	KW	KW	COP	KW	KW	COP	KW	KW	COP	KW	KW	COP	KW	KW	COP	KW	KW	COP
5.0	672.7	158.3	3.8	661.6	182.6	3.3	648.7	210.3	2.9	631.4	241.5	2.4	607.1	260.8	2.2	498.8	229.4	2.0
6.0	691.7	159.3	3.9	680.1	183.1	3.4	666.7	210.7	2.9	647.0	241.1	2.5	621.7	260.9	2.2	503.2	224.4	2.1
7.0	711.0	160.5	4.0	699.0	183.7	3.5	685.1	211.1	3.0	662.9	240.6	2.6	636.5	260.9	2.3	508.1	219.7	2.2
8.0	730.8	162.0	4.1	718.3	184.6	3.6	703.9	211.6	3.1	678.8	240.1	2.6	651.7	260.7	2.4	513.0	215.0	2.2
9.0	750.9	163.6	4.2	737.9	185.6	3.7	723.0	212.2	3.2	695.2	239.6	2.7	667.2	260.4	2.4	517.9	210.3	2.3
10.0	771.3	165.6	4.2	758.0	186.7	3.7	742.4	213.0	3.2	711.9	239.0	2.8	682.9	260.0	2.5	522.6	205.7	2.4
11.0	792.1	167.8	4.3	778.4	188.1	3.8	762.2	213.9	3.3	728.8	238.5	2.9	698.9	259.5	2.5	527.4	201.1	2.4
12.0	813.3	170.2	4.4	799.1	189.8	3.9	782.4	214.9	3.4	745.9	238.1	2.9	715.0	259.0	2.6	532.0	196.6	2.5
13.0	834.9	172.9	4.4	820.2	191.6	3.9	803.0	216.1	3.5	763.0	237.8	3.0	731.6	258.5	2.7	536.6	192.1	2.6

**MODEL: YCAV0739E/V**

## AIR TEMPERATURE ON - CONDENSER (°C)

LCWT (°C)	25.0			30.0			35.0			40.0			45.0			50.0		
	KW	KW	COP	KW	KW	COP	KW	KW	COP	KW	KW	COP	KW	KW	COP	KW	KW	COP
5.0	715.1	166.5	3.9	703.9	191.2	3.4	691.1	219.2	2.9	672.4	250.0	2.5	652.7	273.2	2.2	514.8	227.2	2.1
6.0	735.3	167.7	4.0	723.6	191.9	3.4	710.2	219.8	3.0	689.7	250.2	2.6	668.3	273.3	2.3	519.5	222.3	2.2
7.0	755.9	169.0	4.0	743.7	192.7	3.5	729.7	220.4	3.1	707.4	250.3	2.6	684.3	273.3	2.4	524.7	217.6	2.2
8.0	776.9	170.5	4.1	764.2	193.7	3.6	749.5	221.1	3.1	725.4	250.4	2.7	700.4	273.2	2.4	529.7	213.0	2.3
9.0	798.4	172.3	4.2	785.1	194.9	3.7	769.8	222.0	3.2	743.7	250.5	2.8	717.0	272.9	2.5	534.8	208.4	2.4
10.0	820.2	174.2	4.3	806.4	196.2	3.8	790.5	222.9	3.3	762.5	250.6	2.8	733.7	272.6	2.5	539.7	203.8	2.4
11.0	842.4	176.4	4.3	828.1	197.7	3.8	811.6	223.9	3.4	781.3	250.8	2.9	750.9	272.3	2.6	544.5	199.3	2.5
12.0	864.5	178.7	4.4	850.1	199.4	3.9	833.1	225.2	3.4	799.5	250.5	3.0	768.2	271.9	2.7	549.3	194.9	2.6
13.0	887.0	181.3	4.4	872.1	201.3	4.0	854.8	226.6	3.5	818.1	250.3	3.0	780.0	267.9	2.7	553.9	190.5	2.7

**MODEL: YCAV0819E/V**

## AIR TEMPERATURE ON - CONDENSER (°C)

LCWT (°C)	25.0			30.0			35.0			40.0			45.0			50.0		
	KW	KW	COP	KW	KW	COP	KW	KW	COP	KW	KW	COP	KW	KW	COP	KW	KW	COP
5.0	743.0	172.5	3.9	731.8	196.6	3.4	718.8	223.9	3.0	703.0	255.9	2.6	685.2	280.8	2.3	614.8	279.7	2.1
6.0	764.0	173.7	3.9	752.3	197.7	3.5	738.8	224.8	3.0	722.2	256.8	2.6	701.8	280.9	2.3	620.1	274.4	2.1
7.0	785.4	175.2	4.0	773.3	198.8	3.5	759.2	225.7	3.1	741.8	257.9	2.7	718.6	281.0	2.4	625.7	268.9	2.2
8.0	807.2	176.7	4.1	794.7	200.0	3.6	780.0	226.8	3.2	761.9	259.0	2.7	735.8	281.1	2.4	631.4	263.2	2.2
9.0	829.4	178.3	4.2	816.5	201.3	3.7	801.2	227.9	3.2	782.3	260.0	2.8	753.3	281.1	2.5	637.5	257.2	2.3
10.0	851.7	180.1	4.3	838.7	202.8	3.8	822.9	229.1	3.3	801.1	260.0	2.9	771.2	281.0	2.6	643.5	251.2	2.4
11.0	874.2	182.1	4.3	860.8	204.3	3.8	844.9	230.4	3.4	820.0	260.1	2.9	789.1	281.0	2.6	649.6	245.2	2.5
12.0	897.1	184.2	4.4	883.2	206.0	3.9	866.8	231.9	3.4	839.3	260.1	3.0	807.6	280.9	2.7	655.5	239.3	2.5
13.0	920.3	186.4	4.5	906.1	207.7	4.0	889.1	233.4	3.5	858.7	260.2	3.1	826.3	280.8	2.8	661.0	233.7	2.6

**NOTES:**

1. kW<sub>o</sub> = Unit kW Cooling Capacity Output
2. kW<sub>i</sub> = Compressor kW Input
3. COP = Coefficient of Performance (includes condenser fan power)
4. LCWT = Leaving Chilled Water Temperature
5. Ratings based on 0.15 L/s cooler water per ton, and 0.018 (m<sup>2</sup> - °C)/kW

# High Efficiency Ratings - SI - 50Hz - continued

## MODEL: YCAV0889E/V

### AIR TEMPERATURE ON - CONDENSER (°C)

LCWT (°C)	25.0			30.0			35.0			40.0			45.0			50.0		
	KW	KW	COP	KW	KW	COP	KW	KW	COP	KW	KW	COP	KW	KW	COP	KW	KW	COP
5.0	824.5	198.8	3.8	811.2	226.0	3.3	795.7	256.3	2.9	773.5	289.6	2.5	757.4	320.2	2.2	563.2	246.0	2.1
6.0	847.7	200.4	3.8	833.8	227.5	3.4	817.7	257.7	2.9	793.8	290.7	2.6	775.8	320.9	2.3	568.9	240.7	2.2
7.0	871.3	202.1	3.9	856.9	229.0	3.4	840.1	259.2	3.0	814.6	291.8	2.6	794.7	321.6	2.3	574.4	235.5	2.3
8.0	895.3	204.0	4.0	880.5	230.7	3.5	863.0	260.8	3.1	835.8	292.9	2.7	814.0	322.3	2.4	579.8	230.4	2.3
9.0	919.9	206.0	4.1	904.5	232.4	3.6	886.3	262.5	3.1	856.8	293.7	2.7	821.9	315.3	2.5	585.1	225.3	2.4
10.0	944.8	208.1	4.1	928.9	234.3	3.7	910.1	264.2	3.2	877.5	294.4	2.8	829.9	308.0	2.5	590.4	220.3	2.5
11.0	970.3	210.4	4.2	953.8	236.3	3.7	934.4	266.0	3.3	898.6	295.0	2.9	837.4	300.3	2.6	595.6	215.4	2.5
12.0	995.9	212.9	4.3	979.1	238.4	3.8	959.0	267.9	3.3	920.1	295.6	2.9	844.4	292.5	2.7	600.9	210.6	2.6
13.0	1022.2	214.8	4.4	1004.7	240.7	3.9	984.2	270.0	3.4	941.9	296.3	3.0	850.7	284.8	2.8	605.8	205.9	2.7

## MODEL: YCAV0969E/V

### AIR TEMPERATURE ON - CONDENSER (°C)

LCWT (°C)	25.0			30.0			35.0			40.0			45.0			50.0		
	KW	KW	COP	KW	KW	COP	KW	KW	COP	KW	KW	COP	KW	KW	COP	KW	KW	COP
5.0	935.9	218.7	3.9	919.5	251.0	3.4	900.1	287.1	2.9	875.5	328.5	2.5	840.4	358.3	2.2	696.6	325.1	2.0
6.0	962.5	220.1	4.0	945.8	252.0	3.4	925.6	288.1	3.0	898.2	328.8	2.6	861.1	358.9	2.3	703.3	318.3	2.1
7.0	989.5	221.7	4.0	972.5	253.1	3.5	951.7	289.0	3.0	921.3	328.9	2.6	882.0	359.4	2.3	710.4	311.7	2.1
8.0	1017.1	223.6	4.1	999.6	254.5	3.6	978.3	290.1	3.1	944.1	328.9	2.7	903.6	359.7	2.4	717.2	305.1	2.2
9.0	1045.2	225.6	4.2	1027.4	256.0	3.7	1005.4	291.3	3.2	967.3	328.8	2.8	925.4	360.0	2.4	724.0	298.6	2.3
10.0	1073.8	227.9	4.3	1055.6	257.6	3.8	1033.0	292.7	3.3	991.0	328.8	2.8	947.7	360.1	2.5	730.8	292.1	2.3
11.0	1102.8	230.5	4.3	1084.4	259.5	3.8	1061.2	294.2	3.3	1015.0	328.8	2.9	970.5	360.1	2.5	737.3	285.7	2.4
12.0	1132.3	233.4	4.4	1113.6	261.7	3.9	1089.8	295.8	3.4	1039.3	328.8	3.0	993.5	360.2	2.6	743.9	279.3	2.5
13.0	1162.3	236.4	4.5	1143.3	264.0	4.0	1119.1	297.6	3.5	1063.8	328.9	3.0	1017.0	360.2	2.7	750.4	273.1	2.5

## MODEL: YCAV1039E/V

### AIR TEMPERATURE ON - CONDENSER (°C)

LCWT (°C)	25.0			30.0			35.0			40.0			45.0			50.0		
	KW	KW	COP	KW	KW	COP	KW	KW	COP	KW	KW	COP	KW	KW	COP	KW	KW	COP
5.0	996.2	229.9	3.9	979.2	265.0	3.4	959.5	304.9	2.9	935.5	351.4	2.5	900.4	380.5	2.2	758.5	348.2	2.0
6.0	1024.5	231.3	4.0	1007.0	265.7	3.5	986.4	305.6	3.0	960.5	351.8	2.6	922.3	380.7	2.3	765.3	340.6	2.1
7.0	1053.4	233.1	4.1	1035.3	266.7	3.6	1013.9	306.1	3.1	984.3	351.2	2.6	944.6	380.6	2.3	772.8	333.6	2.2
8.0	1082.9	235.1	4.2	1064.2	267.8	3.6	1042.0	306.9	3.1	1008.6	350.5	2.7	967.2	380.5	2.4	780.2	326.5	2.2
9.0	1112.9	237.5	4.2	1093.7	269.3	3.7	1070.7	307.8	3.2	1033.1	349.9	2.8	990.4	380.1	2.4	787.7	319.5	2.3
10.0	1143.5	240.2	4.3	1123.7	271.0	3.8	1100.0	309.0	3.3	1058.1	349.1	2.8	1014.2	379.6	2.5	795.1	312.6	2.4
11.0	1174.4	243.3	4.4	1154.4	273.0	3.9	1129.9	310.2	3.4	1083.6	348.5	2.9	1038.3	379.0	2.6	802.3	305.7	2.4
12.0	1206.4	246.8	4.4	1185.5	275.4	3.9	1160.4	311.7	3.4	1109.5	347.9	3.0	1062.9	378.3	2.6	809.4	299.0	2.5
13.0	1238.7	250.7	4.5	1217.3	278.0	4.0	1191.4	313.5	3.5	1135.6	347.4	3.1	1087.6	377.7	2.7	816.5	292.3	2.6

### NOTES:

1. kW<sub>o</sub> = Unit kW Cooling Capacity Output
2. kW<sub>i</sub> = Compressor kW Input
3. COP = Coefficient of Performance (includes condenser fan power)
4. LCWT = Leaving Chilled Water Temperature
5. Ratings based on 0.15 L/s cooler water per ton, and 0.018 (m<sup>2</sup> - °C)/kW

**MODEL: YCAV1169E/V**

## AIR TEMPERATURE ON - CONDENSER (°C)

LCWT (°C)	25.0			30.0			35.0			40.0			45.0			50.0		
	KW	KW	COP	KW	KW	COP	KW	KW	COP	KW	KW	COP	KW	KW	COP	KW	KW	COP
5.0	1082.7	253.0	3.9	1064.7	290.5	3.4	1044.3	333.1	2.9	1013.0	378.6	2.5	979.4	411.6	2.2	771.5	343.4	2.1
6.0	1113.5	254.7	4.0	1094.7	291.6	3.4	1073.2	334.0	3.0	1038.5	378.7	2.6	1002.8	411.8	2.3	778.6	336.0	2.2
7.0	1145.0	256.7	4.0	1125.3	292.9	3.5	1102.8	335.0	3.1	1064.7	378.6	2.6	1026.6	411.8	2.3	786.2	329.0	2.2
8.0	1177.1	259.0	4.1	1156.5	294.4	3.6	1133.0	336.2	3.1	1091.4	378.6	2.7	1050.8	411.7	2.4	793.7	322.0	2.3
9.0	1209.8	261.7	4.2	1188.4	296.2	3.7	1164.0	337.5	3.2	1118.6	378.5	2.8	1075.6	411.4	2.5	801.3	315.1	2.3
10.0	1243.2	264.6	4.3	1221.0	298.3	3.8	1195.5	338.9	3.3	1146.4	378.5	2.8	1100.7	411.0	2.5	808.6	308.3	2.4
11.0	1277.2	267.9	4.3	1254.2	300.7	3.8	1227.8	340.6	3.3	1174.3	378.4	2.9	1126.5	410.5	2.6	816.0	301.5	2.5
12.0	1311.9	271.6	4.4	1288.1	303.3	3.9	1260.7	342.5	3.4	1201.8	378.0	3.0	1152.6	410.0	2.6	823.1	294.9	2.6
13.0	1347.3	275.7	4.5	1322.6	306.1	4.0	1294.1	344.8	3.5	1229.8	377.6	3.0	1170.5	404.2	2.7	830.2	288.2	2.6

**MODEL: YCAV1309E/V**

## AIR TEMPERATURE ON - CONDENSER (°C)

LCWT (°C)	25.0			30.0			35.0			40.0			45.0			50.0		
	KW	KW	COP	KW	KW	COP	KW	KW	COP	KW	KW	COP	KW	KW	COP	KW	KW	COP
5.0	1228.4	292.9	3.8	1206.7	332.0	3.3	1181.0	375.3	2.9	1146.5	424.4	2.5	1124.2	471.7	2.2	875.6	387.7	2.1
6.0	1263.2	295.5	3.9	1241.1	334.3	3.4	1214.5	377.6	3.0	1177.1	426.0	2.6	1152.5	473.1	2.3	884.3	379.5	2.2
7.0	1298.8	298.2	4.0	1276.1	336.8	3.5	1248.7	379.9	3.0	1208.5	427.5	2.6	1181.6	474.3	2.3	892.9	371.3	2.2
8.0	1334.9	301.0	4.0	1311.8	339.4	3.6	1283.4	382.5	3.1	1240.5	429.2	2.7	1211.3	475.5	2.4	901.4	363.2	2.3
9.0	1371.6	304.2	4.1	1348.0	342.3	3.6	1318.9	385.1	3.2	1273.1	430.8	2.8	1241.6	476.7	2.5	909.7	355.2	2.4
10.0	1409.1	307.4	4.2	1384.9	345.2	3.7	1355.0	388.0	3.2	1306.1	432.6	2.8	1272.4	478.0	2.5	917.9	347.3	2.4
11.0	1447.1	310.9	4.2	1422.5	348.3	3.8	1391.8	390.9	3.3	1339.8	434.4	2.9	1296.7	474.5	2.6	926.0	339.6	2.5
12.0	1485.7	314.6	4.3	1460.6	351.7	3.8	1429.2	394.0	3.4	1372.9	435.7	3.0	1307.9	462.5	2.7	934.0	332.0	2.6
13.0	1525.2	317.4	4.4	1499.4	355.2	3.9	1467.3	397.2	3.4	1406.5	437.2	3.0	1318.4	450.7	2.7	941.8	324.6	2.7

**MODEL: YCAV1429E/V**

## AIR TEMPERATURE ON - CONDENSER (°C)

LCWT (°C)	25.0			30.0			35.0			40.0			45.0			50.0		
	KW	KW	COP	KW	KW	COP	KW	KW	COP	KW	KW	COP	KW	KW	COP	KW	KW	COP
5.0	1311.3	305.8	3.9	1289.5	353.0	3.3	1264.6	406.2	2.9	1234.0	468.0	2.5	1190.2	507.1	2.2	1009.0	466.4	2.0
6.0	1348.7	307.5	4.0	1326.3	353.9	3.4	1300.1	407.0	3.0	1268.1	469.3	2.5	1219.1	507.5	2.3	1019.4	456.7	2.1
7.0	1386.9	309.7	4.0	1363.8	355.0	3.5	1336.4	407.8	3.0	1299.9	468.6	2.6	1248.8	507.6	2.3	1028.3	446.7	2.1
8.0	1424.6	312.1	4.1	1401.9	356.4	3.6	1373.5	408.7	3.1	1332.1	467.7	2.7	1278.7	507.4	2.4	1038.3	437.2	2.2
9.0	1462.7	314.9	4.2	1439.2	358.2	3.7	1411.1	409.8	3.2	1364.5	466.8	2.7	1309.6	507.0	2.4	1048.3	427.9	2.3
10.0	1501.5	318.1	4.3	1477.4	360.1	3.8	1448.4	411.1	3.3	1397.8	465.9	2.8	1341.0	506.3	2.5	1058.3	418.6	2.3
11.0	1540.7	321.9	4.3	1516.1	362.4	3.8	1486.3	412.7	3.3	1431.1	465.0	2.9	1373.1	505.6	2.6	1067.9	409.3	2.4
12.0	1580.6	326.0	4.4	1555.5	365.1	3.9	1524.9	414.5	3.4	1464.2	464.2	2.9	1405.7	504.7	2.6	1077.5	400.3	2.5
13.0	1621.3	330.6	4.5	1595.4	368.3	4.0	1564.1	416.5	3.5	1497.8	463.5	3.0	1438.1	503.9	2.7	1087.1	391.3	2.6

**NOTES:**

1. kW<sub>o</sub> = Unit kW Cooling Capacity Output
2. kW<sub>i</sub> = Compressor kW Input
3. COP = Coefficient of Performance (includes condenser fan power)
4. LCWT = Leaving Chilled Water Temperature
5. Ratings based on 0.15 L/s cooler water per ton, and 0.018 (m<sup>2</sup> - °C)/kW

# High Efficiency Ratings - SI - 50Hz - continued

## MODEL: YCAV1549E/V

### AIR TEMPERATURE ON - CONDENSER (°C)

LCWT (°C)	25.0			30.0			35.0			40.0			45.0			50.0		
	KW	KW	COP	KW	KW	COP	KW	KW	COP	KW	KW	COP	KW	KW	COP	KW	KW	COP
5.0	1445.2	333.3	3.9	1421.6	382.4	3.4	1394.8	438.5	2.9	1355.8	500.1	2.5	1315.0	546.5	2.3	1035.8	456.3	2.1
6.0	1486.4	335.6	4.0	1461.7	383.8	3.5	1433.6	439.6	3.0	1390.7	500.4	2.6	1346.5	546.7	2.3	1045.4	446.4	2.2
7.0	1528.4	338.3	4.1	1502.7	385.6	3.6	1473.3	440.8	3.1	1426.6	500.6	2.7	1378.7	546.6	2.4	1055.6	437.2	2.2
8.0	1571.4	341.5	4.2	1544.5	387.6	3.6	1513.8	442.4	3.2	1463.3	500.8	2.7	1411.5	546.4	2.4	1065.8	427.9	2.3
9.0	1615.2	345.1	4.2	1587.3	390.0	3.7	1555.2	444.1	3.2	1500.7	501.0	2.8	1445.0	545.9	2.5	1075.9	418.8	2.4
10.0	1659.8	349.0	4.3	1630.9	392.8	3.8	1597.6	446.0	3.3	1538.8	501.3	2.9	1479.0	545.3	2.5	1085.7	409.6	2.4
11.0	1705.5	353.5	4.4	1675.3	396.0	3.9	1640.8	448.2	3.4	1577.1	501.5	2.9	1513.8	544.5	2.6	1095.5	400.7	2.5
12.0	1751.9	358.5	4.4	1720.7	399.4	3.9	1684.9	450.7	3.5	1614.2	501.0	3.0	1549.0	543.8	2.7	1105.1	391.8	2.6
13.0	1799.3	364.0	4.5	1767.0	403.3	4.0	1729.7	453.7	3.5	1652.0	500.5	3.1	1573.1	535.9	2.8	1114.5	383.0	2.7

## MODEL: YCAV1739E/V

### AIR TEMPERATURE ON - CONDENSER (°C)

LCWT (°C)	25.0			30.0			35.0			40.0			45.0			50.0		
	KW	KW	COP	KW	KW	COP	KW	KW	COP	KW	KW	COP	KW	KW	COP	KW	KW	COP
5.0	1590.0	373.2	3.9	1562.9	423.8	3.4	1530.9	480.6	2.9	1488.9	545.8	2.5	1459.4	606.6	2.3	1131.3	496.0	2.1
6.0	1635.3	376.3	3.9	1607.4	426.5	3.4	1574.2	483.1	3.0	1529.0	547.6	2.6	1495.9	607.9	2.3	1142.6	485.5	2.2
7.0	1681.5	379.7	4.0	1652.7	429.4	3.5	1618.4	485.7	3.1	1570.1	549.4	2.7	1533.4	609.0	2.4	1153.8	475.1	2.2
8.0	1728.4	383.4	4.1	1699.0	432.5	3.6	1663.4	488.7	3.1	1611.9	551.3	2.7	1571.6	610.1	2.4	1164.9	464.8	2.3
9.0	1776.2	387.5	4.2	1746.0	436.0	3.7	1709.5	491.6	3.2	1654.7	553.3	2.8	1610.6	611.1	2.5	1175.7	454.6	2.4
10.0	1825.0	391.8	4.2	1794.0	439.7	3.7	1756.3	494.9	3.3	1698.2	555.3	2.9	1650.3	612.2	2.5	1186.2	444.5	2.5
11.0	1874.2	396.4	4.3	1842.8	443.5	3.8	1804.0	498.4	3.4	1742.0	557.4	2.9	1681.8	607.4	2.6	1196.8	434.7	2.5
12.0	1923.6	401.4	4.4	1892.0	447.8	3.9	1852.7	502.0	3.4	1784.7	558.6	3.0	1696.2	591.9	2.7	1207.4	425.0	2.6
13.0	1974.3	405.6	4.4	1941.6	452.2	3.9	1901.7	506.0	3.5	1828.1	560.0	3.1	1709.4	576.3	2.8	1217.6	415.5	2.7

#### NOTES:

1. kW<sub>o</sub> = Unit kW Cooling Capacity Output
2. kW<sub>i</sub> = Compressor kW Input
3. COP = Coefficient of Performance (includes condenser fan power)
4. LCWT = Leaving Chilled Water Temperature
5. Ratings based on 0.15 L/s cooler water per ton, and 0.018 (m<sup>2</sup> - °C)/kW

**NOTES:**

1. kW<sub>o</sub> = Unit kW Cooling Capacity Output
2. kW<sub>i</sub> = Compressor kW Input
3. COP = Coefficient of Performance (includes condenser fan power)
4. LCWT = Leaving Chilled Water Temperature
5. Ratings based on 0.15 L/s cooler water per ton, and 0.018 (m<sup>2</sup> – °C)/kW

# Physical Data (English - Standard Efficiency)

Refrigerant R-134a	STANDARD EFFICIENCY						
	MODEL NUMBER (YCAV S/P)						
	YCAV0157	YCAV0177	YCAV0187	YCAV0207	YCAV0227	YCAV0247	YCAV0267
<b>General Unit Data</b>							
Number of Independent Refrigerant Circuits	2	2	2	2	2	2	2
Refrigerant Charge, R-134a, Ckt.-1/Ckt.-2, lbs	162/162	170/170	185/170	192/175	192/192	230/195	230/230
Oil Charge, Ckt.-1/Ckt.-2, gal.	5/5	5/5	5/5	5/5	5/5	5/5	5/5
Compressors, Semi-hermetic Screw Qty per Chiller	2	2	2	2	2	2	2
<b>Condensers, High Efficiency Fin/Tube with Integral Subcooler</b>							
Total Chiller Coil Face Area, ft <sup>2</sup>	235	235	264	264	293	323	352
Number of Rows	3	3	3	3	3	3	3
Fins per Inch	17	17	17	17	17	17	17
<b>Condenser Fans</b>							
Number, Ckt.-1/Ckt.-2	4/4	4/4	5/4	5/4	5/5	6/5	6/6
<b>Low Sound Fans</b>							
Fan Motor, HP	2	2	2	2	2	2	2
Fan & Motor Speed, revs./min.	1140	1140	1140	1140	1140	1140	1140
Fan Diameter, inches	35.4	35.4	35.4	35.4	35.4	35.4	35.4
Fan Tip Speed, ft./min.	10575	10575	10575	10575	10575	10575	10575
Total Chiller Airflow, cfm	104000	104000	117000	117000	130000	143000	156000
<b>Ultra Quiet Fans</b>							
Fan Motor, HP	2	2	2	2	2	2	2
Fan & Motor Speed, revs./min.	838	838	838	838	838	838	838
Fan Diameter, inches	35.4	35.4	35.4	35.4	35.4	35.4	35.4
Fan Tip Speed, ft./min.	7774	7774	7774	7774	7774	7774	7774
Total Chiller Airflow, cfm	104000	104000	117000	117000	130000	143000	156000
<b>Evaporator, Direct Expansion</b>							
Water Volume, gals.	67.0	95.0	95.0	140.0	140.0	140.0	140.0
Maximum Water Side Pressure, psig <sup>1</sup>	150	150	150	150	150	150	150
Maximum Refrigerant Side Pressure, psig	235	235	235	235	235	235	235
Minimum Chilled Water Flow Rate, gpm	140	160	160	180	180	180	180
Maximum Chilled Water Flow Rate, gpm	675	750	750	800	800	800	800
Water Connections, inches	8	10	10	10	10	10	10

<sup>1</sup> Optional 300 psig Waterside available

Contact your nearest Johnson Controls Sales Office for weight data.



# Physical Data (English - High Efficiency)

Refrigerant R-134a	HIGH EFFICIENCY						
	MODEL NUMBER (YCAV E/V)						
General Unit Data	YCAV0157	YCAV0177	YCAV0187	YCAV0197	YCAV0207	YCAV0227	YCAV0247
Number of Independent Refrigerant Circuits	2	2	2	2	2	2	2
Refrigerant Charge, R-134a, Ckt.-1/Ckt.-2, lbs	170/170	185/170	185/185	192/192	225/192	225/225	230/230
Oil Charge, Ckt.-1/Ckt.-2, gal.	5/5	5/5	5/5	5/5	5/5	5/5	5/5
Compressors, Semi-hermetic Screw Qty per Chiller	2	2	2	2	2	2	2
<b>Condensers, High Efficiency Fin/Tube with Integral Subcooler</b>							
Total Chiller Coil Face Area, ft <sup>2</sup>	235	264	293	293	323	352	352
Number of Rows	3	3	3	3	3	3	3
Fins per Inch	17	17	17	17	17	17	17
<b>Condenser Fans</b>							
Number, Ckt.-1/Ckt.-2	4/4	5/4	5/5	5/5	6/5	6/6	6/6
<b>Low Sound Fans</b>							
Fan Motor, HP	2	2	2	2	2	2	2
Fan & Motor Speed, revs./min.	1140	1140	1140	1140	1140	1140	1140
Fan Diameter, inches	35.4	35.4	35.4	35.4	35.4	35.4	35.4
Fan Tip Speed, ft./min.	10575	10575	10575	10575	10575	10575	10575
Total Chiller Airflow, cfm	104000	117000	130000	130000	143000	156000	156000
<b>Ultra Quiet Fans</b>							
Fan Motor, HP	2	2	2	2	2	2	2
Fan & Motor Speed, revs./min.	838	838	838	838	838	838	838
Fan Diameter, inches	35.4	35.4	35.4	35.4	35.4	35.4	35.4
Fan Tip Speed, ft./min.	7774	7774	7774	7774	7774	7774	7774
Total Chiller Airflow, cfm	104000	117000	130000	130000	143000	156000	156000
<b>Evaporator, Direct Expansion</b>							
Water Volume, gals.	95.0	95.0	95.0	110.0	110.0	110.0	140.0
Maximum Water Side Pressure, psig <sup>1</sup>	150	150	150	150	150	150	150
Maximum Refrigerant Side Pressure, psig	235	235	235	235	235	235	235
Minimum Chilled Water Flow Rate, gpm	160	160	160	180	180	180	180
Maximum Chilled Water Flow Rate, gpm	750	750	750	750	750	750	800
Water Connections, inches	10	10	10	10	10	10	10

<sup>1</sup> Optional 300 psig Waterside available

Contact your nearest Johnson Controls Sales Office for weight data.

# Physical Data (English - Standard Efficiency)

Refrigerant R-134a	STANDARD EFFICIENCY									
	MODEL NUMBER (YCAV ___ S/P)									
	60Hz	YCAV0287	YCAV0307	YCAV0357	YCAV0397	YCAV0417	YCAV0457	YCAV0477	YCAV0507	YCAV0527
50Hz	-	-	-	-	-	YCAV1549	YCAV1649	YCAV1739	YCAV1829	YCAV1909
<b>General Unit Data</b>										
Number of Independent Refrigerant Circuits	3	3	3	3	4	4	4	4	4	4
Refrigerant Charge, R-134a, Ckt.-1/Ckt.-2, lbs	185/170/170	185/185/170	185/185/230	230/230/230	185/185/185/185	230/185/185/185	230/230/185/185	230/230/185/185	230/230/230/230	230/230/230/230
Oil Charge, Ckt.-1/Ckt.-2, gal.	5/4/4	5/4/4	5/5/5	5/5/5	5/5/5/5	5/5/5/5	5/5/5/5	5/5/5/5	5/5/5/5	5/5/5/5
Glycol Charge (43% concentration), gal	5.4	5.5	6.0	6.3	9.2	9.3	9.4	9.8	9.9	
<b>Compressors, Semi-hermetic Screw</b>										
Quantity per Chiller	3	3	3	3	4	4	4	4	4	4
<b>Condensers, High Efficiency Fin/Tube with Integral Subcooler</b>										
Total Chiller Coil Face Area, ft <sup>2</sup>	381	411	469	528	587	616	645	645	704	
Number of Rows	3	3	3	3	3	3	3	3	3	3
Fins per Inch	17	17	17	17	17	17	17	17	17	17
<b>Condenser Fans</b>										
Number, Ckt.-1/Ckt.-2	5/4/4	5/4/4	5/5/6	6/6/6	5/5/5/5	6/5/5/5	6/5/5/5	6/6/5/6	6/6/6/6	
<b>Low Noise Fans</b>										
Fan Motor, HP/kW	2/1.8	2/1.8	2/1.8	2/1.8	2/1.8	2/1.8	2/1.8	2/1.8	2/1.8	2/1.8
Fan & Motor Speed, revs./min.	1140	1140	1140	1140	1140	1140	1140	1140	1140	1140
Fan Diameter, inches	35.4	35.4	35.4	35.4	35.4	35.4	35.4	35.4	35.4	35.4
Fan Tip Speed, ft./min.	10575	10575	10575	10575	10575	10575	10575	10575	10575	10575
Total Chiller Airflow, cfm	169000	182000	208000	234000	260000	273000	286000	286000	312000	
<b>Ultra Quiet Fans</b>										
Fan Motor, HP/kW	2/1.50	2/1.50	2/1.50	2/1.50	2/1.50	2/1.50	2/1.50	2/1.50	2/1.50	2/1.50
Fan & Motor Speed, revs./min.	838	838	838	838	838	838	838	838	838	838
Fan Diameter, inches	35.4	35.4	35.4	35.4	35.4	35.4	35.4	35.4	35.4	35.4
Fan Tip Speed, ft./min.	7774	7774	7774	7774	7774	7774	7774	7774	7774	7774
Total Chiller Airflow, cfm	169000	182000	208000	234000	260000	273000	286000	286000	312000	
<b>Evaporator, Direct Expansion</b>										
Water Volume, gals.	202.0	236.0	236.0	236.0	266.0	266.0	318.0	318.0	318.0	
Maximum Water Side Pressure, psig	150	150	150	150	150	150	150	150	150	150
Maximum Refrigerant Side Pressure, psig	235	235	235	235	235	235	235	235	235	235
Minimum Chilled Water Flow Rate, gpm	250	300	300	300	350	350	400	400	400	400
Maximum Chilled Water Flow Rate, gpm	1200	1200	1200	1200	1250	1250	1400	1400	1400	1400
Water Connections, inches	10	10	10	10	10	10	10	10	10	10

Contact your nearest Johnson Controls Sales Office for weight data.

# Physical Data (English - High Efficiency)

Refrigerant R-134a	HIGH EFFICIENCY							
	MODEL NUMBER (YCAV ___ E/V)							
	60Hz	YCAV0267	YCAV0287	YCAV0327	YCAV0357	YCAV0397	YCAV0417	YCAV0477
	50Hz	-	-	-	-	YCAV1429	YCAV1549	YCAV1739
<b>General Unit Data</b>								
Number of Independent Refrigerant Circuits	3	3	3	3	4	4	4	
Refrigerant Charge, R-134a, Ckt.-1/Ckt.-2, lbs	185/185/170	185/185/230	185/185/230	230/230/230	185/185/ 185/185	230/230/ 185/185	230/230/ 230/230	
Oil Charge, Ckt.-1/Ckt.-2, gal.	5/5/4	5/5/5	5/5/5	5/5/5	5/5/5/5	5/5/5/5	5/5/5/5	
Glycol Charge (43% concentration), gal	5.5	5.7	6.0	6.3	9.2	9.4	9.6	
<b>Compressors, Semi-hermetic Screw</b>								
Quantity per Chiller	3	3	3	3	4	4	4	
<b>Condensers, High Efficiency Fin/Tube with Integral Subcooler</b>								
Total Chiller Coil Face Area, ft <sup>2</sup>	411	469	469	528	569	645	704	
Number of Rows	3	3	3	3	3	3	3	
Fins per Inch	17	17	17	17	17	17	17	
<b>Condenser Fans</b>								
Number, Ckt.-1/Ckt.-2	5/5/4	5/5/6	5/5/6	6/6/6	5/5/5/5	6/6/5/5	6/6/6/6	
<b>Low Noise Fans</b>								
Fan Motor, HP/kW	2/1.8	2/1.8	2/1.8	2/1.8	2/1.8	2/1.8	2/1.8	
Fan & Motor Speed, revs./min.	1140	1140	1140	1140	1140	1140	1140	
Fan Diameter, inches	35.4	35.4	35.4	35.4	35.4	35.4	35.4	
Fan Tip Speed, ft./min.	10575	10575	10575	10575	10575	10575	10575	
Total Chiller Airflow, cfm	182000	208000	208000	234000	260000	286000	312000	
<b>Ultra Quiet Fans</b>								
Fan Motor, HP/kW	2/1.50	2/1.50	2/1.50	2/1.50	2/1.50	2/1.50	2/1.50	
Fan & Motor Speed, revs./min.	838	838	838	838	838	838	838	
Fan Diameter, inches	35.4	35.4	35.4	35.4	35.4	35.4	35.4	
Fan Tip Speed, ft./min.	7774	7774	7774	7774	7774	7774	7774	
Total Chiller Airflow, cfm	182000	208000	208000	234000	260000	286000	312000	
<b>Evaporator, Direct Expansion</b>								
Water Volume, gals.	202.0	202.0	236.0	236.0	266.0	318.0	318.0	
Maximum Water Side Pressure, psig	150	150	150	150	150	150	150	
Maximum Refrigerant Side Pressure, psig	235	235	235	235	235	235	235	
Minimum Chilled Water Flow Rate, gpm	250	250	300	300	350	400	400	
Maximum Chilled Water Flow Rate, gpm	1200	1200	1200	1200	1250	1400	1400	
Water Connections, inches	10	10	10	10	10	10	10	

Contact your nearest Johnson Controls Sales Office for weight data.

# Physical Data (SI - Standard Efficiency)

Refrigerant R-134a	STANDARD EFFICIENCY						
	MODEL NUMBER (YCAV___ S/P)						
	YCAV0157	YCAV0177	YCAV0187	YCAV0207	YCAV0227	YCAV0247	YCAV0267
<b>General Unit Data</b>							
Number of Independent Refrigerant Circuits	2	2	2	2	2	2	2
Refrigerant Charge, R-134a, Ckt.-1/Ckt.-2, kg.	74/74	77/77	84/77	87/80	87/87	105/89	105/105
Oil Charge, Ckt.-1/Ckt.-2, liters	19/19	19/19	19/19	19/19	19/19	19/19	19/19
Compressors, Semi-hermetic Screw Qty per Chiller	2	2	2	2	2	2	2
<b>Condensers, High Efficiency Fin/Tube with Integral Subcooler</b>							
Total Chiller Coil Face Area, m <sup>2</sup>	21.8	21.8	24.5	24.5	27.2	30.0	32.7
Number of Rows	3	3	3	3	3	3	3
Fins per meter	669	669	669	669	669	669	669
<b>Condenser Fans</b>							
Number, Ckt.-1/Ckt.-2	4/4	4/4	5/4	5/4	5/5	6/5	6/6
<b>Low Sound Fans</b>							
Fan Motor, HP/kw	2/1.50	2/1.50	2/1.50	2/1.50	2/1.50	2/1.50	2/1.50
Fan & Motor Speed, revs./sec.	19.0	19.0	19.0	19.0	19.0	19.0	19.0
Fan Diameter, mm	899	899	899	899	899	899	899
Fan Tip Speed, m/sec.	53.7	53.7	53.7	53.7	53.7	53.7	53.7
Total Chiller Airflow, l/sec.	49082	49082	55218	55218	61353	67488	73624
<b>Ultra Quiet Fans</b>							
Fan Motor, HP/kw	2/1.50	2/1.50	2/1.50	2/1.50	2/1.50	2/1.50	2/1.50
Fan & Motor Speed, revs./sec.	14.0	14.0	14.0	14.0	14.0	14.0	14.0
Fan Diameter, mm	899	899	899	899	899	899	899
Fan Tip Speed, m/sec.	39	39	39	39	39	39	39
Total Chiller Airflow, l/sec.	49082	49082	55218	55218	61353	67488	73624
<b>Evaporator, Direct Expansion</b>							
Water Volume, liters	253.6	359.6	359.6	529.9	529.9	529.9	529.9
Maximum Water Side Pressure, Bar <sup>1</sup>	10	10	10	10	10	10	10
Maximum Refrigerant Side Pressure, Bar	16	16	16	16	16	16	16
Minimum Chilled Water Flow Rate, l/sec.	8.8	10.1	10.1	11.4	11.4	11.4	11.4
Maximum Chilled Water Flow Rate, l/sec.	42.6	47.3	47.3	50.5	50.5	50.5	50.5
Water Connections, inches	8	10	10	10	10	10	10

<sup>1</sup> Optional 21 Bar Waterside available

Contact your nearest Johnson Controls Sales Office for weight data.

# Physical Data (SI - High Efficiency)

Refrigerant R-134a	HIGH EFFICIENCY						
	MODEL NUMBER (YCAV___ E/V)						
General Unit Data	YCAV0157	YCAV0177	YCAV0187	YCAV0197	YCAV0207	YCAV0227	YCAV0247
Number of Independent Refrigerant Circuits	2	2	2	2	2	2	2
Refrigerant Charge, R-134a, Ckt.-1/Ckt.-2, kg.	77/77	84/77	84/84	87/87	102/87	102/102	105/105
Oil Charge, Ckt.-1/Ckt.-2, liters	19/19	19/19	19/19	19/19	19/19	19/19	19/19
Compressors, Semi-hermetic Screw Qty per Chiller	2	2	2	2	2	2	2
<b>Condensers, High Efficiency Fin/Tube with Integral Subcooler</b>							
Total Chiller Coil Face Area, m <sup>2</sup>	21.8	24.5	27.2	27.2	30.0	32.7	32.7
Number of Rows	3	3	3	3	3	3	3
Fins per meter	669	669	669	669	669	669	669
<b>Condenser Fans</b>							
Number, Ckt.-1/Ckt.-2	4/4	5/4	5/5	5/5	6/5	6/6	6/6
<b>Standard Fans</b>							
Fan Motor, HP/kw	2/1.50	2/1.50	2/1.50	2/1.50	2/1.50	2/1.50	2/1.50
Fan & Motor Speed, revs./sec.	19.0	19.0	19.0	19.0	19.0	19.0	19.0
Fan Diameter, mm	899	899	899	899	899	899	899
Fan Tip Speed, m/sec.	53.7	53.7	53.7	53.7	53.7	53.7	53.7
Total Chiller Airflow, l/sec.	49082	55218	61353	61353	67488	73624	73624
<b>Low Noise Fans</b>							
Fan Motor, HP/kw	2/1.50	2/1.50	2/1.50	2/1.50	2/1.50	2/1.50	2/1.50
Fan & Motor Speed, revs./sec.	14.0	14.0	14.0	14.0	14.0	14.0	14.0
Fan Diameter, mm	899	899	899	899	899	899	899
Fan Tip Speed, m/sec.	39	39	39	39	39	39	39
Total Chiller Airflow, l/sec.	49082	55218	61353	61353	67488	73624	73624
<b>Evaporator, Direct Expansion</b>							
Water Volume, liters	359.6	359.6	359.6	416.4	416.4	416.4	529.9
Maximum Water Side Pressure, Bar <sup>1</sup>	10	10	10	10	10	10	10
Maximum Refrigerant Side Pressure, Bar	16	16	16	16	16	16	16
Minimum Chilled Water Flow Rate, l/sec.	10.1	10.1	10.1	11.4	11.4	11.4	11.4
Maximum Chilled Water Flow Rate, l/sec.	47.3	47.3	47.3	47.3	47.3	47.3	50.5
Water Connections, inches	10	10	10	10	10	10	10

<sup>1</sup> Optional 21 Bar Waterside available

Contact your nearest Johnson Controls Sales Office for weight data.

# Physical Data (SI - Standard Efficiency)

Refrigerant R-134a	STANDARD EFFICIENCY									
	MODEL NUMBER (YCAV ___ S/P)									
	60Hz	YCAV0287	YCAV0307	YCAV0357	YCAV0397	YCAV0417	YCAV0457	YCAV0477	YCAV0507	YCAV0527
	50Hz	-	-	-	-	YCAV1549	YCAV1649	YCAV1739	YCAV1829	YCAV1909
<b>General Unit Data</b>										
Number of Independent Refrigerant Circuits		3	3	3	3	4	4	4	4	4
Refrigerant Charge, R-134a, Ckt.-1/Ckt.-2, kg.		84 / 77 / 77	84 / 84 / 77	84 / 84 / 105	105 / 105 / 105	84 / 84 / 84 / 84	105 / 84 / 84 / 84	105 / 105 / 84 / 84	105 / 105 / 84 / 84	105 / 105 / 105 / 105
Oil Charge, Ckt.-1/Ckt.-2, liters		19 / 15 / 15	19 / 19 / 15	19 / 19 / 19	19 / 19 / 19	19 / 19 / 19 / 19	19 / 19 / 19 / 19	19 / 19 / 19 / 19	19 / 19 / 19 / 19	19 / 19 / 19 / 19
Glycol Charge (43% concentration), liters		0	0	0	0	0	0	0	0	0
<b>Compressors, Semi-hermetic Screw</b>										
Quantity per Chiller		3	3	3	3	4	4	4	4	4
<b>Condensers, High Efficiency Fin/Tube with Integral Subcooler</b>										
Total Chiller Coil Face Area, m <sup>2</sup>		35	38	44	49	55	57	60	60	65
Number of Rows		3	3	3	3	3	3	3	3	3
Fins per meter		669	669	669	669	669	669	669	669	669
<b>Condenser Fans</b>										
Number, Ckt.-1/Ckt.-2		5/4/4	5/5/4	5/5/6	6/6/6	5 / 5 / 5 / 5	6 / 5 / 5 / 5	6 / 6 / 5 / 5	6 / 6 / 5 / 6	6 / 6 / 6 / 6
<b>Standard Fans</b>										
Fan Motor, HP/kW		2/1.50	2/1.50	2/1.50	2/1.50	2/1.50	2/1.50	2/1.50	2/1.50	2/1.50
Fan & Motor Speed, revs./sec.		19	19	19	19	19	19	19	19	19
Fan Diameter, mm		899.2	899.2	899.2	899.2	899.2	899.2	899.2	899.2	899.2
Fan Tip Speed, m/sec.		54	54	54	54	54	54	54	54	54
Total Chiller Airflow, l/sec.		79768	85904	98176	110448	122720	128856	134992	134992	147264
<b>Low Noise Fans</b>										
Fan Motor, HP/kW		2/1.50	2/1.50	2/1.50	2/1.50	2/1.50	2/1.50	2/1.50	2/1.50	2/1.50
Fan & Motor Speed, revs./sec.		14	14	14	14	14	14	14	14	14
Fan Diameter, mm		899.2	899.2	899.2	899.2	899.2	899.2	899.2	899.2	899.2
Fan Tip Speed, m/sec.		39	39	39	39	39	39	39	39	39
Total Chiller Airflow, l/sec.		79768	85904	98176	110448	122720	128856	134992	134992	147264
<b>Evaporator, Direct Expansion</b>										
Water Volume, liters		764.6	893.3	893.3	893.3	1006.8	1006.8	1203.6	1203.6	1203.6
Maximum Water Side Pressure, Bar		10	10	10	10	10	10	10	10	10
Maximum Refrigerant Side Pressure, Bar		16	16	16	16	16	16	16	16	16
Minimum Chilled Water Flow Rate, l/sec.		16	19	19	19	22	22	25	25	25
Maximum Chilled Water Flow Rate, l/sec.		76	76	76	76	79	79	88	88	88
Water Connections, mm		245	245	245	245	245	245	245	245	245

Contact your nearest Johnson Controls Sales Office for weight data.

# Physical Data (SI - High Efficiency)

Refrigerant R-134a	HIGH EFFICIENCY							
	MODEL NUMBER (YCAV ___ E/V)							
	60Hz	YCAV0267	YCAV0287	YCAV0327	YCAV0357	YCAV0397	YCAV0417	YCAV0477
	50Hz	-	-	-	-	YCAV1429	YCAV1549	YCAV1739
<b>General Unit Data</b>								
Number of Independent Refrigerant Circuits	3	3	3	3	4	4	4	4
Refrigerant Charge, R-134a, Ckt.-1/Ckt.-2, kg.	84 / 84 / 77	84 / 84 / 105	84 / 84 / 105	105 / 105 / 105	84 / 84 / 84 / 84	105 / 105 / 84 / 84	105 / 105 / 105 / 105	105 / 105 / 105 / 105
Oil Charge, Ckt.-1/Ckt.-2, liters	19 / 19 / 15	19 / 19 / 19	19 / 19 / 19	19 / 19 / 19	19 / 19 / 19 / 19	19 / 19 / 19 / 19	19 / 19 / 19 / 19	19 / 19 / 19 / 19
Glycol Charge (43% concentration), liters	0	0	0	0	0	0	0	0
<b>Compressors, Semi-hermetic Screw</b>								
Quantity per Chiller	3	3	3	3	4	4	4	4
<b>Condensers, High Efficiency Fin/Tube with Integral Subcooler</b>								
Total Chiller Coil Face Area, m <sup>2</sup>	38	44	44	49	53	60	65	65
Number of Rows	3	3	3	3	3	3	3	3
Fins per meter	669	669	669	669	669	669	669	669
<b>Condenser Fans</b>								
Number, Ckt.-1/Ckt.-2	05/05/04	05/05/06	05/05/06	06/06/06	5 / 5 / 5 / 5	6 / 6 / 5 / 5	6 / 6 / 6 / 6	6 / 6 / 6 / 6
<b>Standard Fans</b>								
Fan Motor, HP/kW	2/1.50	2/1.50	2/1.50	2/1.50	2/1.50	2/1.50	2/1.50	2/1.50
Fan & Motor Speed, revs./sec.	19	19	19	19	19	19	19	19
Fan Diameter, mm	899.2	899.2	899.2	899.2	899.2	899.2	899.2	899.2
Fan Tip Speed, m/sec.	54	54	54	54	54	54	54	54
Total Chiller Airflow, l/sec.	85904	98176	98176	110448	122720	134992	147264	147264
<b>Low Noise Fans</b>								
Fan Motor, HP/kW	2/1.50	2/1.50	2/1.50	2/1.50	2/1.50	2/1.50	2/1.50	2/1.50
Fan & Motor Speed, revs./sec.	14	14	14	14	14	14	14	14
Fan Diameter, mm	899.2	899.2	899.2	899.2	899.2	899.2	899.2	899.2
Fan Tip Speed, m/sec.	39	39	39	39	39	39	39	39
Total Chiller Airflow, l/sec.	85904	98176	98176	110448	122720	134992	147264	147264
<b>Evaporator, Direct Expansion</b>								
Water Volume, liters	764.6	764.6	893.3	893.3	1006.8	1203.6	1203.6	1203.6
Maximum Water Side Pressure, Bar	10	10	10	10	10	10	10	10
Maximum Refrigerant Side Pressure, Bar	16	16	16	16	16	16	16	16
Minimum Chilled Water Flow Rate, l/sec.	16	16	19	19	22	25	25	25
Maximum Chilled Water Flow Rate, l/sec.	76	76	76	76	79	88	88	88
Water Connections, mm	245	245	245	245	245	245	245	245

Contact your nearest Johnson Controls Sales Office for weight data.

# Dimensions - English

## YCAV0157S/P

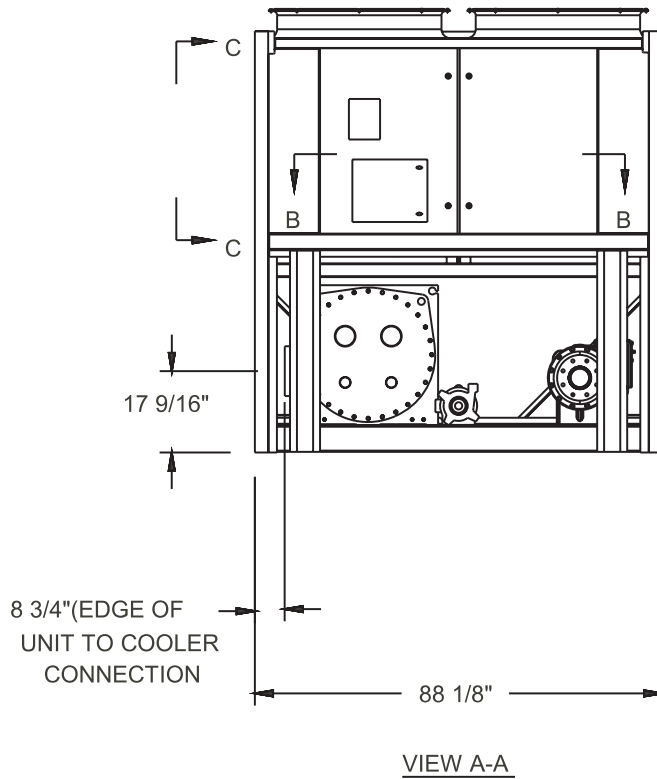
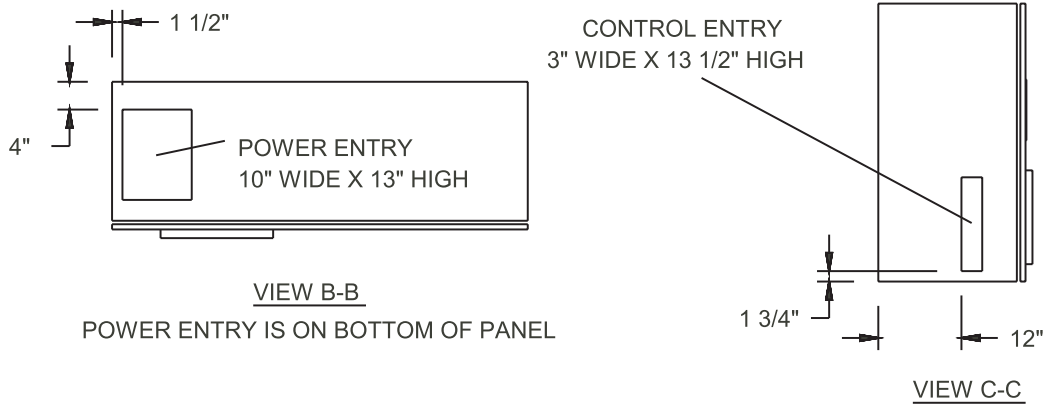

### Notes:

1. Placement on a level surface free of obstructions (including snow, for winter operation) or air recirculation ensure rated performance, reliable operation, and ease of maintenance. Site restrictions may compromise minimum clearances indicated below, resulting in unpredictable air patterns and possible diminished performance. Johnson Controls' unit controls will optimize the operation without nuisance high pressure safety cutouts; however, the system designer MUST consider potential performance degradation.
2. Access to the unit control center stipulates the unit is no higher when on spring isolators. Recommended minimum clearances: side to wall - 6"; rear to wall - 6"; control panel end to wall - 4"; top - no obstructions whatsoever; distance between adjacent units - 10'. No more than one adjacent wall may be higher than the unit.





# Dimensions - English - continued

## YCAV0157E/V, 0177S/P

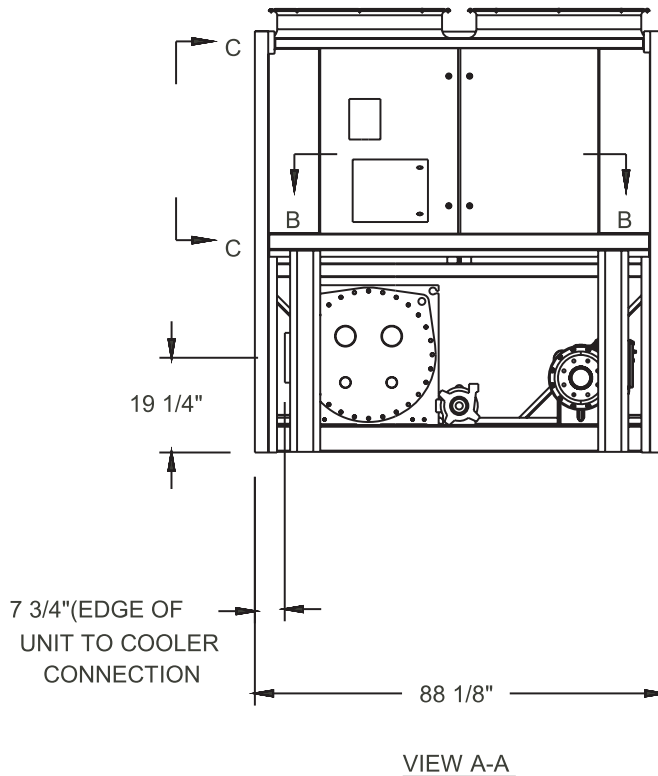
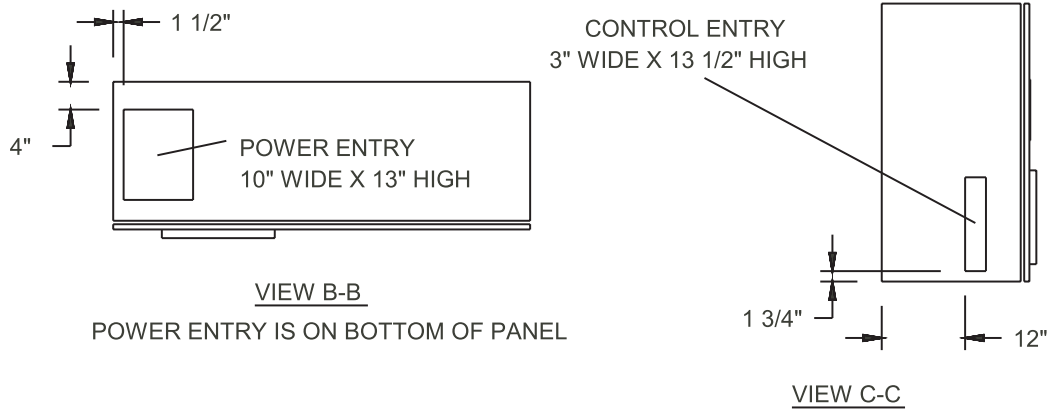

### Notes:

1. Placement on a level surface free of obstructions (including snow, for winter operation) or air recirculation ensure rated performance, reliable operation, and ease of maintenance. Site restrictions may compromise minimum clearances indicated below, resulting in unpredictable air patterns and possible diminished performance. Johnson Controls' unit controls will optimize the operation without nuisance high pressure safety cutouts; however, the system designer MUST consider potential performance degradation.
2. Access to the unit control center stipulates the unit is no higher when on spring isolators. Recommended minimum clearances: side to wall - 6'; rear to wall - 6'; control panel end to wall - 4'; top - no obstructions whatsoever; distance between adjacent units - 10'. No more than one adjacent wall may be higher than the unit.

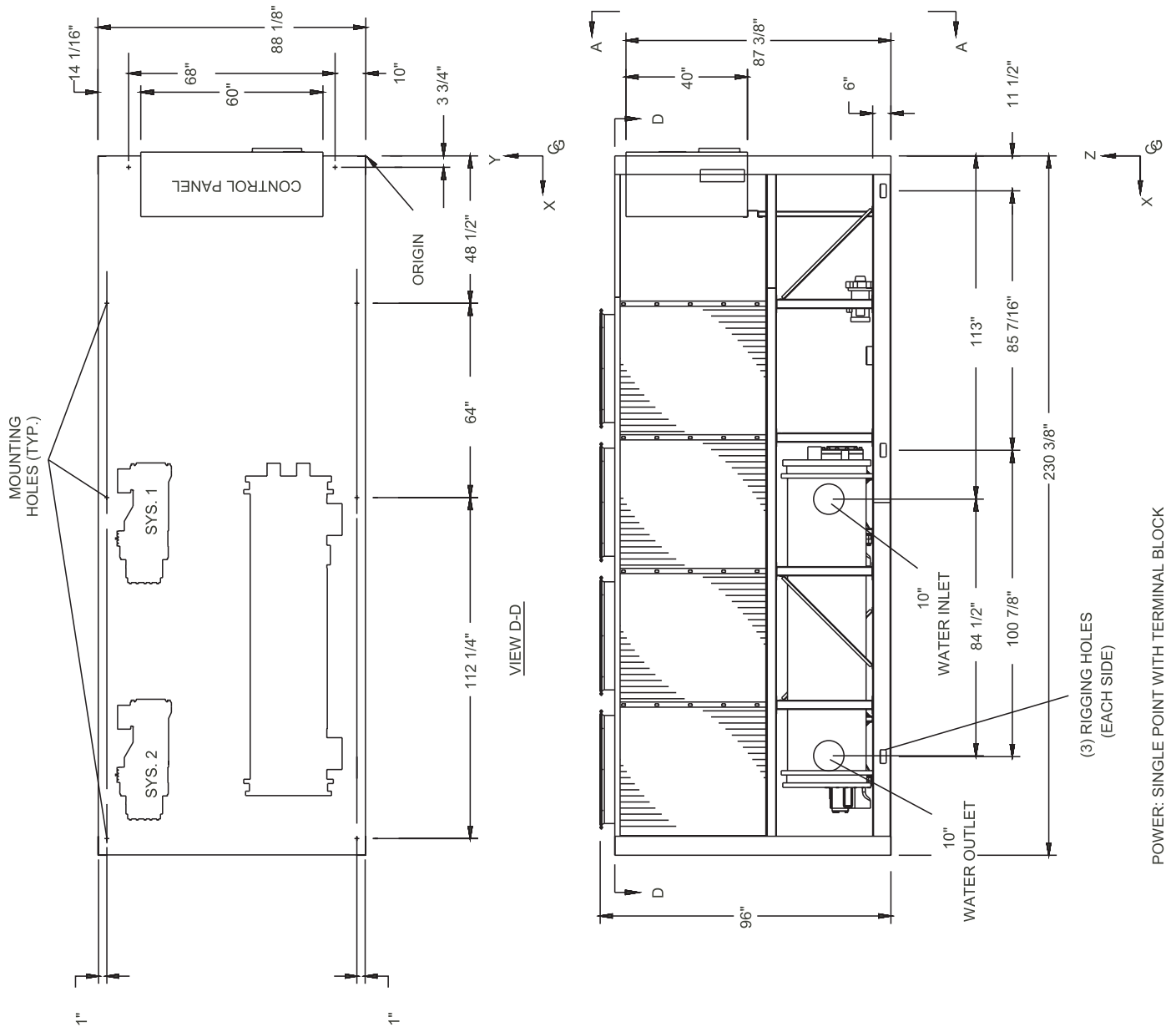

# Dimensions - English - continued

## YCAV0177E/V, 0187S/P, 0187E/V

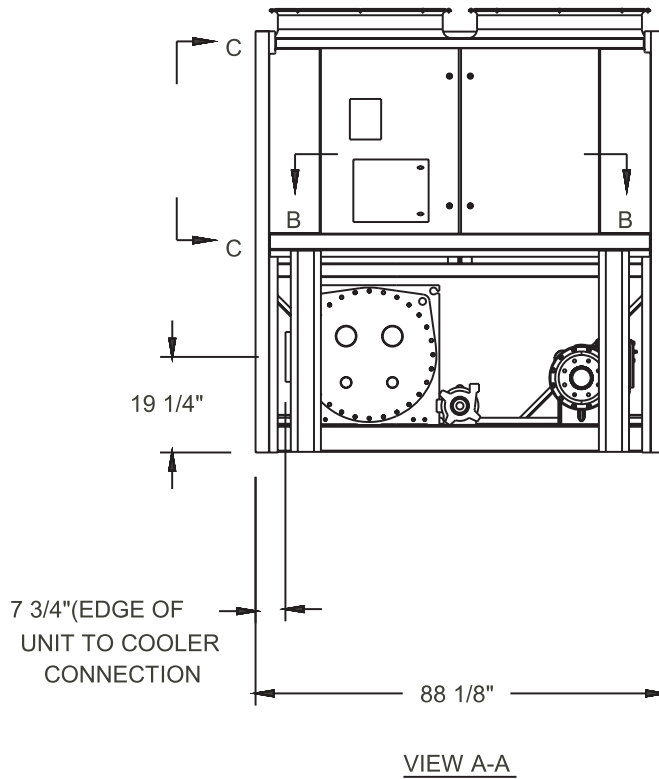
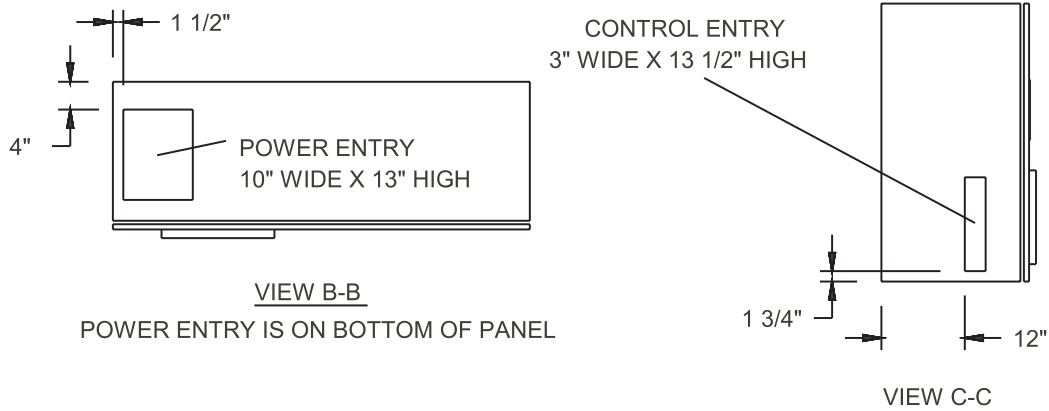

### Notes:

1. Placement on a level surface free of obstructions (including snow, for winter operation) or air recirculation ensure rated performance, reliable operation, and ease of maintenance. Site restrictions may compromise minimum clearances indicated below, resulting in unpredictable air patterns and possible diminished performance. Johnson Controls' unit controls will optimize the operation without nuisance high pressure safety cutouts; however, the system designer MUST consider potential performance degradation.
2. Access to the unit control center stipulates the unit is no higher when on spring isolators. Recommended minimum clearances: side to wall - 6'; rear to wall - 6'; control panel end to wall - 4'; top - no obstructions whatsoever; distance between adjacent units - 10'. No more than one adjacent wall may be higher than the unit.

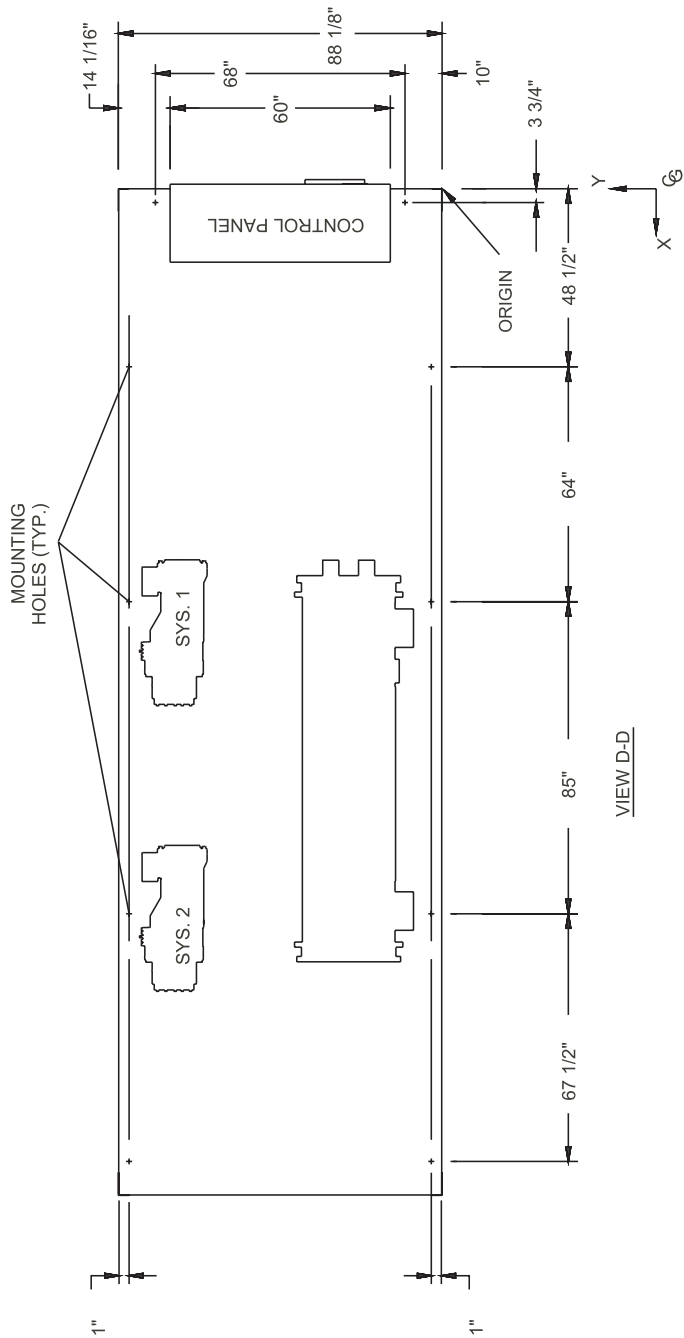

VIEW D-D

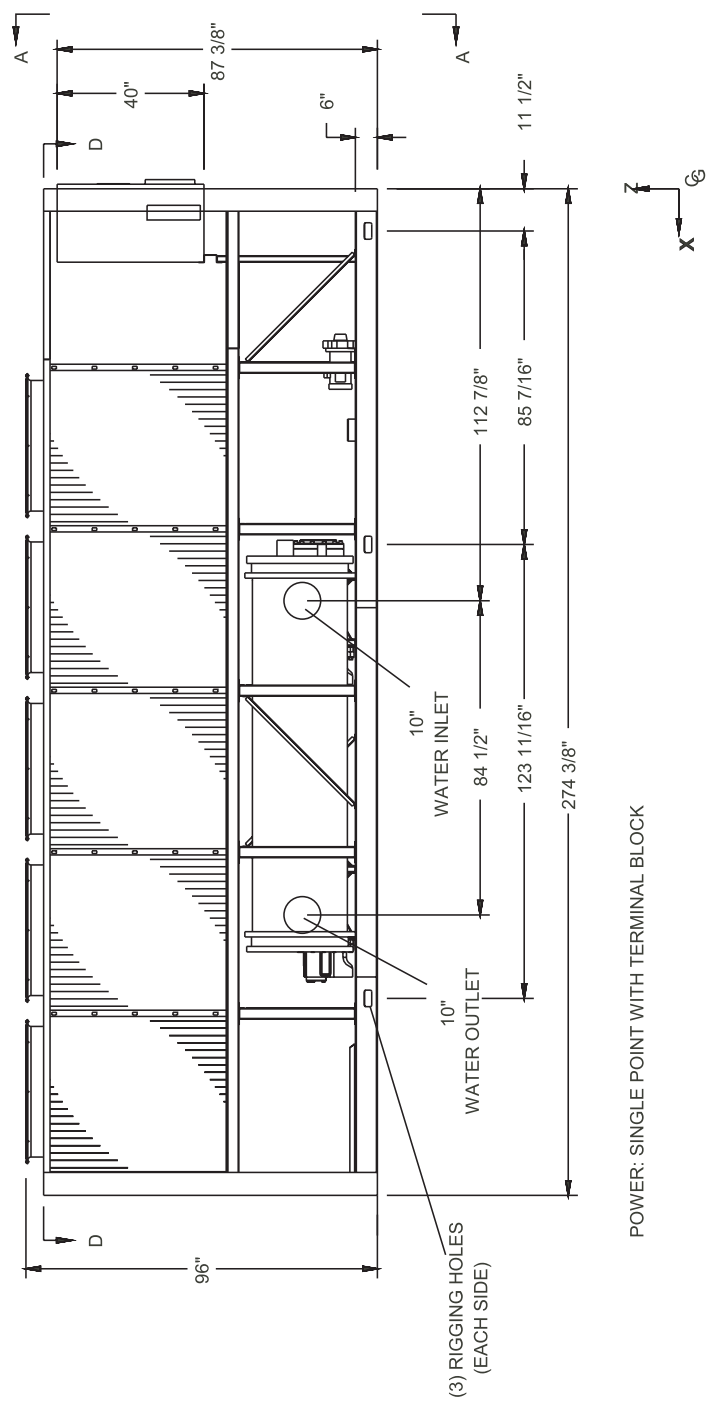

# Dimensions - English - continued

## YCAV0197E/V

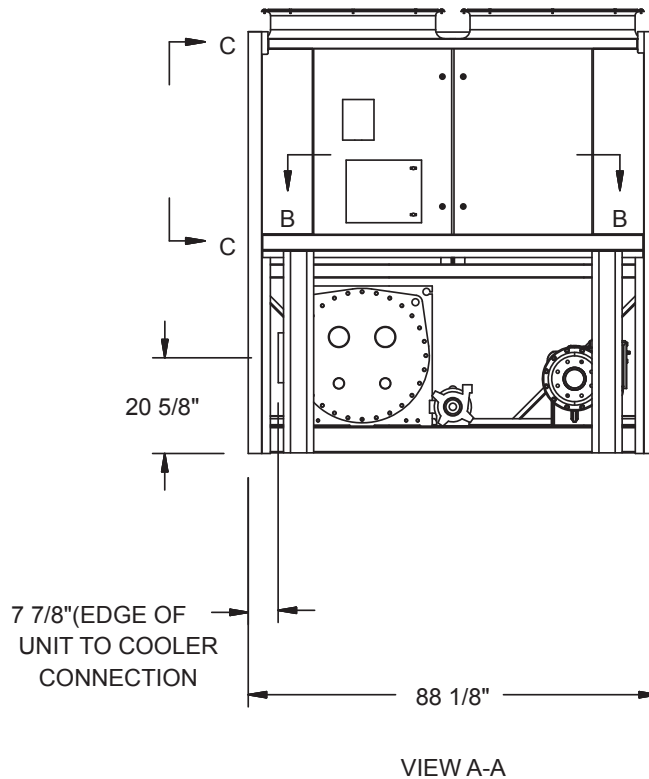
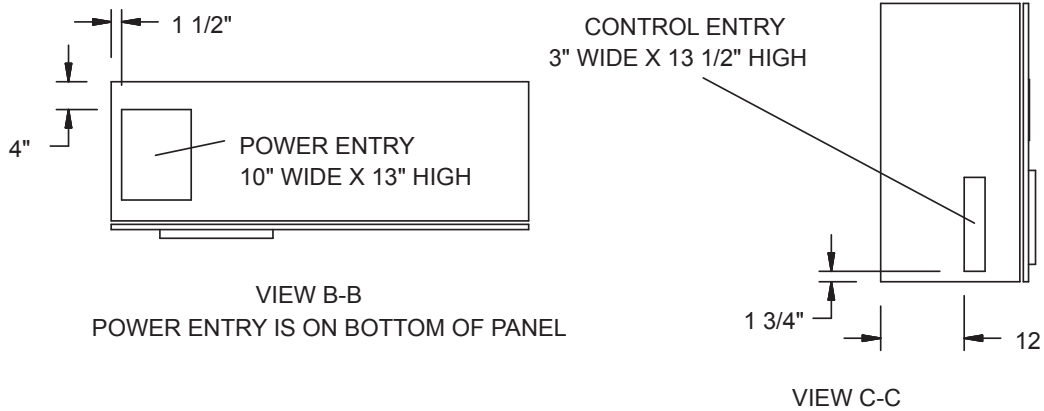

### Notes:

1. Placement on a level surface free of obstructions (including snow, for winter operation) or air recirculation ensure rated performance, reliable operation, and ease of maintenance. Site restrictions may compromise minimum clearances indicated below, resulting in unpredictable air patterns and possible diminished performance. Johnson Controls' unit controls will optimize the operation without nuisance high pressure safety cutouts; however, the system designer MUST consider potential performance degradation.
2. Access to the unit control center stipulates the unit is no higher when on spring isolators. Recommended minimum clearances: side to wall - 6'; rear to wall - 6'; control panel end to wall - 4'; top - no obstructions whatsoever; distance between adjacent units - 10'. No more than one adjacent wall may be higher than the unit.

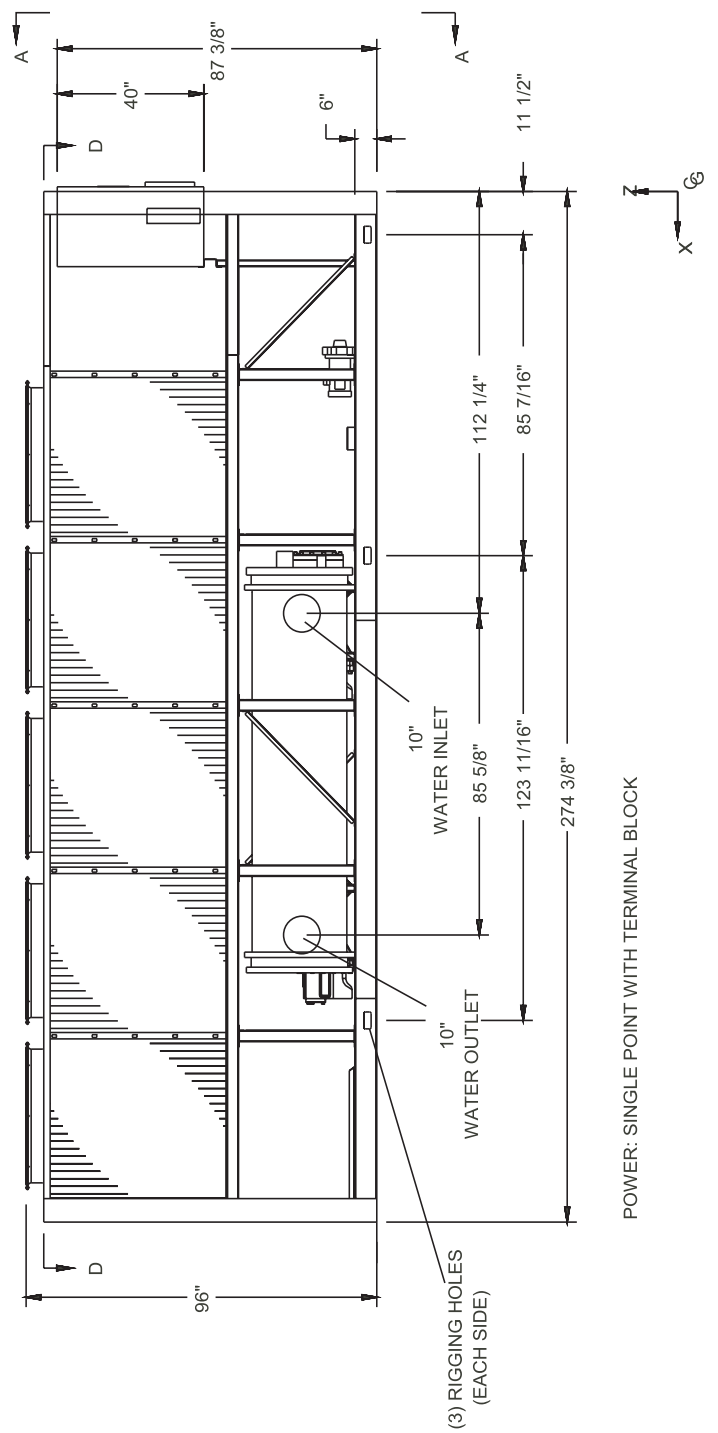
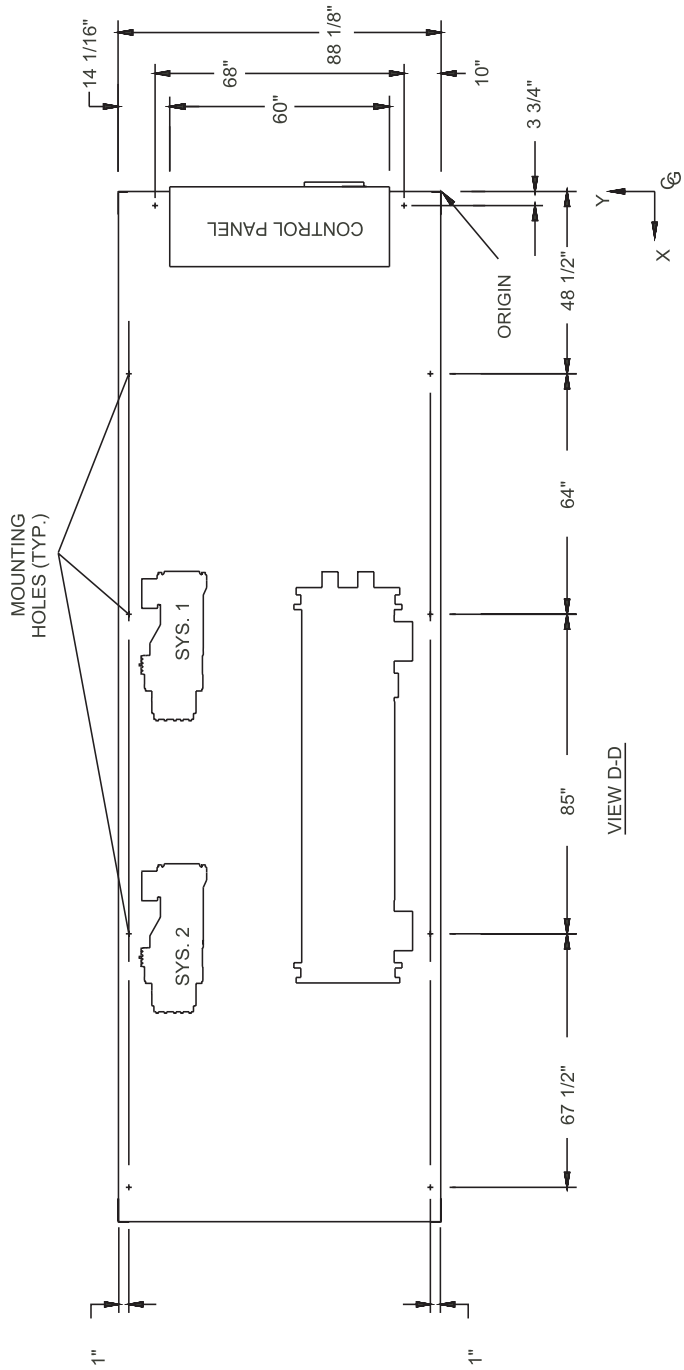

POWER: SINGLE POINT WITH TERMINAL BLOCK

# Dimensions - English - continued

## YCAV0207S/P, 0227S/P

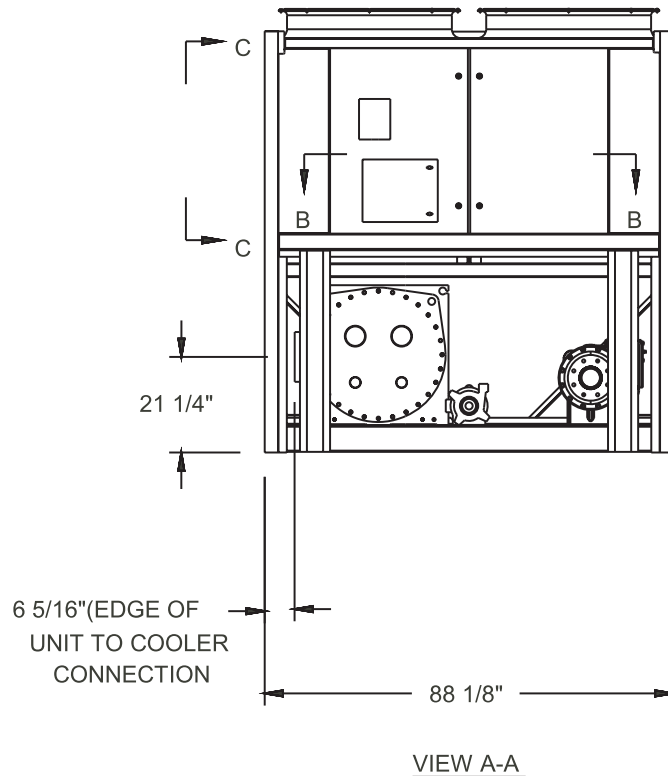
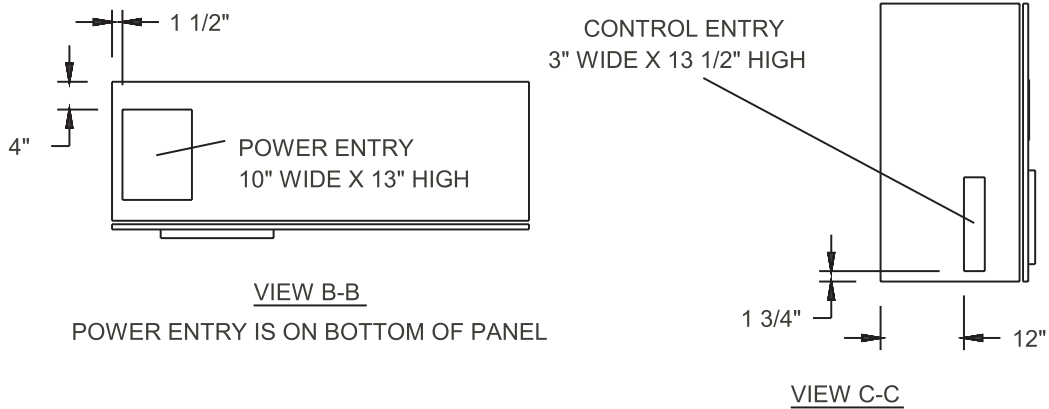

### Notes:

1. Placement on a level surface free of obstructions (including snow, for winter operation) or air recirculation ensure rated performance, reliable operation, and ease of maintenance. Site restrictions may compromise minimum clearances indicated below, resulting in unpredictable air patterns and possible diminished performance. Johnson Controls' unit controls will optimize the operation without nuisance high pressure safety cutouts; however, the system designer MUST consider potential performance degradation.
2. Access to the unit control center stipulates the unit is no higher when on spring isolators. Recommended minimum clearances: side to wall - 6'; rear to wall - 6'; control panel end to wall - 4'; top - no obstructions whatsoever; distance between adjacent units - 10'. No more than one adjacent wall may be higher than the unit.



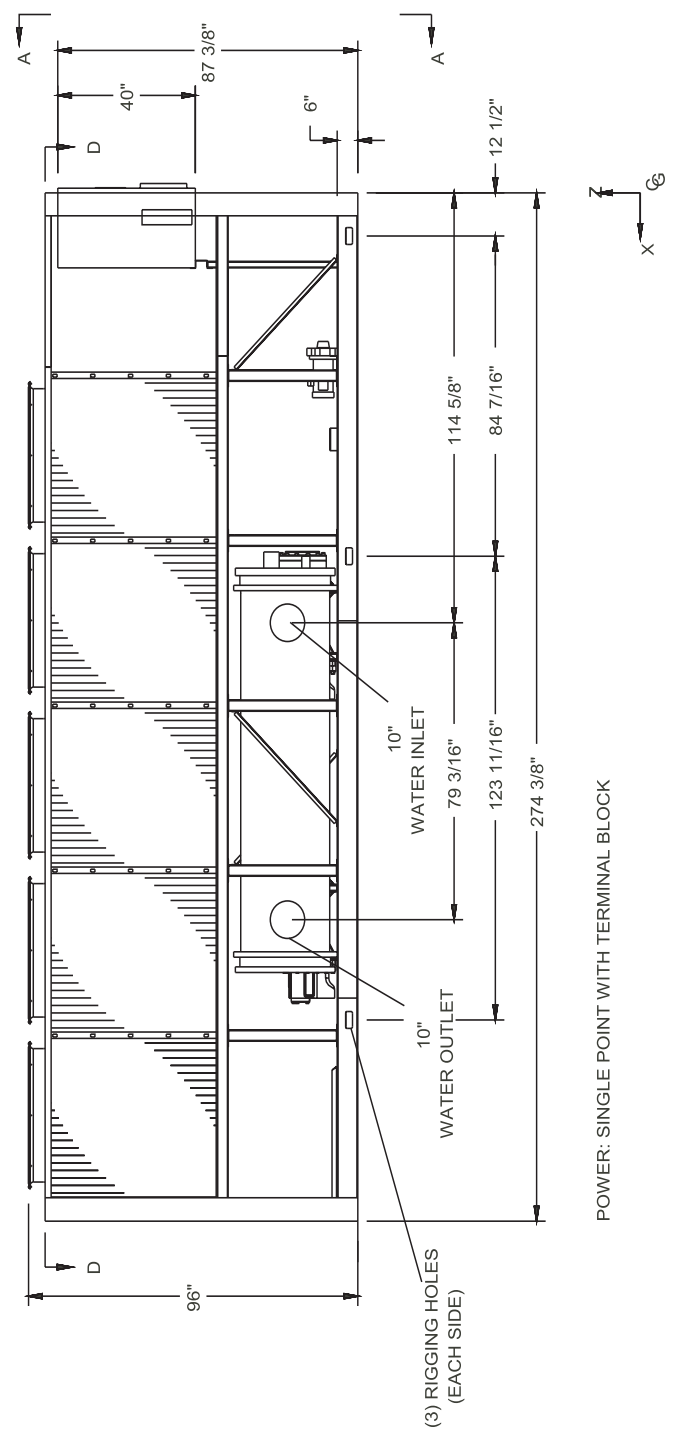
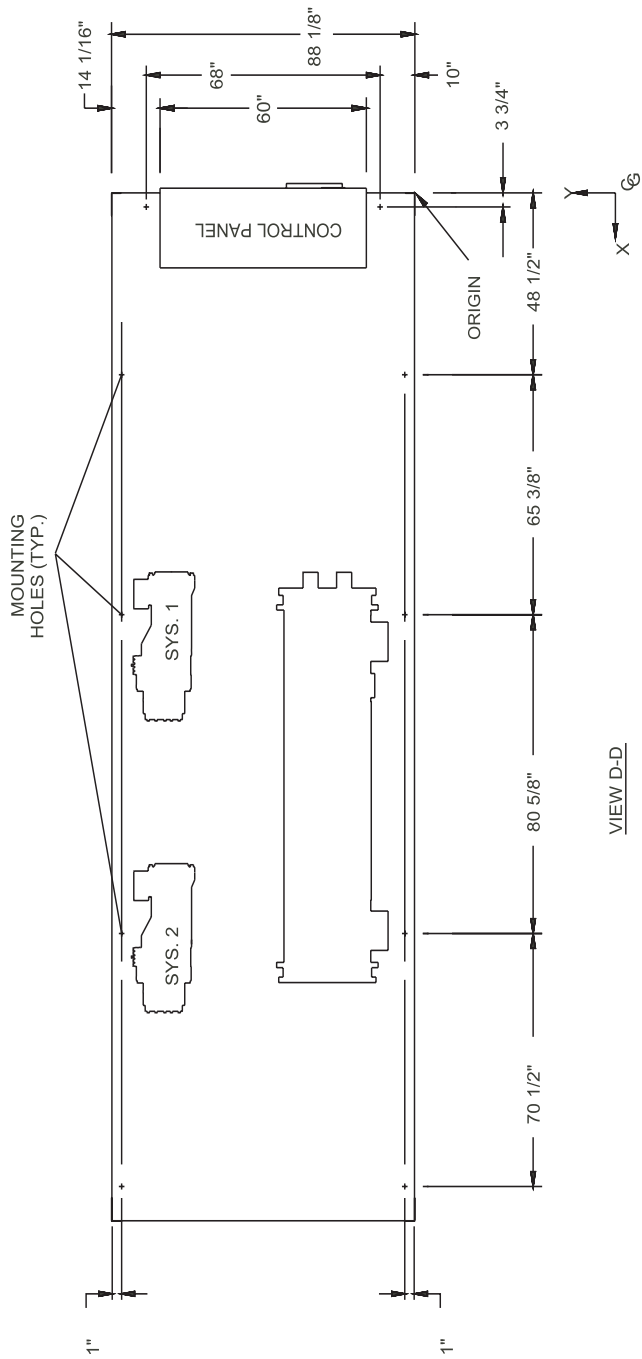

# Dimensions - English - continued

## YCAV0207E/V, 0227E/V

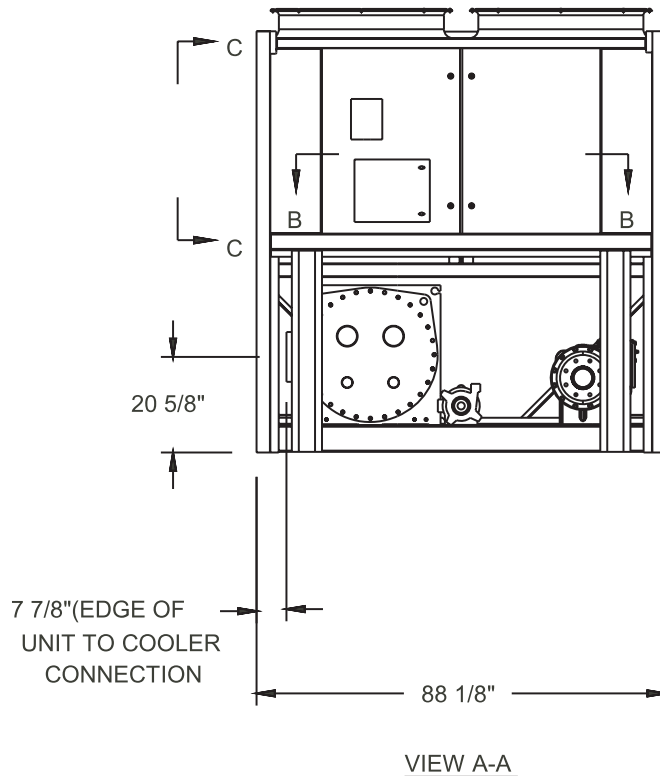
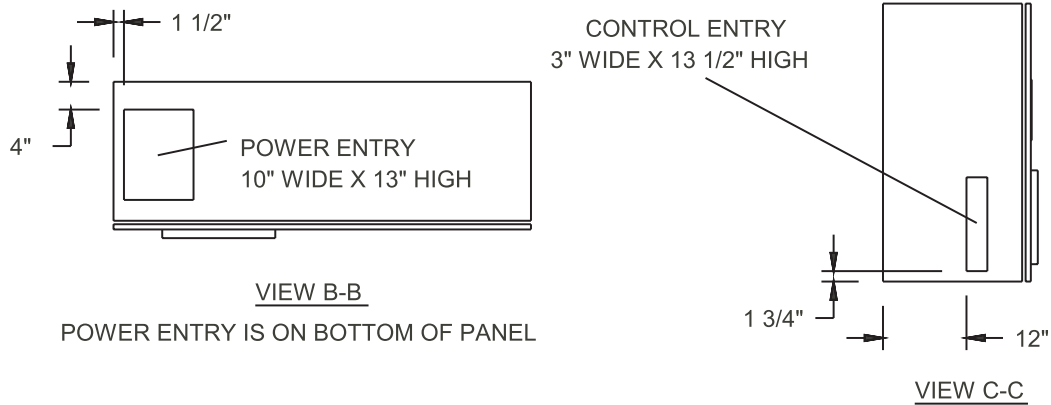

### Notes:

1. Placement on a level surface free of obstructions (including snow, for winter operation) or air recirculation ensure rated performance, reliable operation, and ease of maintenance. Site restrictions may compromise minimum clearances indicated below, resulting in unpredictable air patterns and possible diminished performance. Johnson Controls' unit controls will optimize the operation without nuisance high pressure safety cutouts; however, the system designer MUST consider potential performance degradation.
2. Access to the unit control center stipulates the unit is no higher when on spring isolators. Recommended minimum clearances: side to wall - 6'; rear to wall - 6'; control panel end to wall - 4'; top - no obstructions whatsoever; distance between adjacent units - 10'. No more than one adjacent wall may be higher than the unit.



# Dimensions - English - continued

## YCAV0247S/P, 0247E/V, 0267S/P

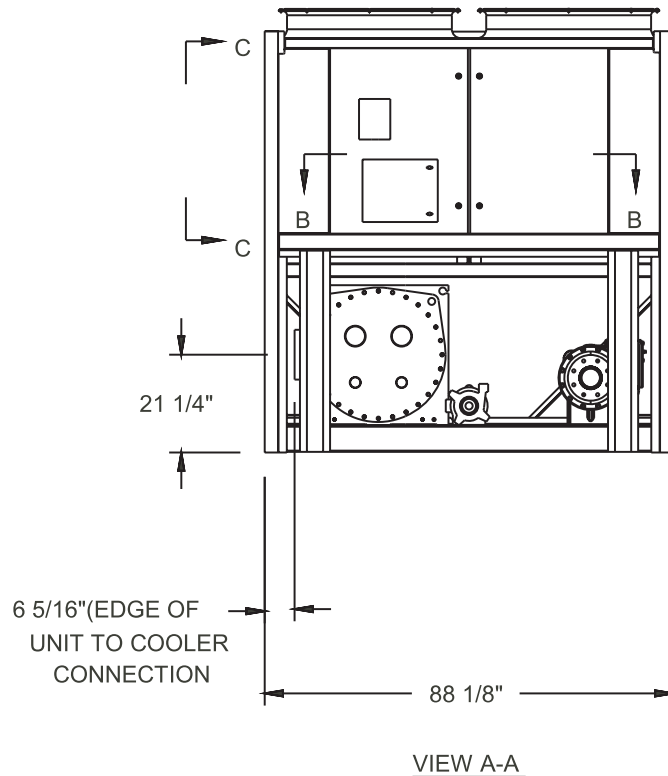
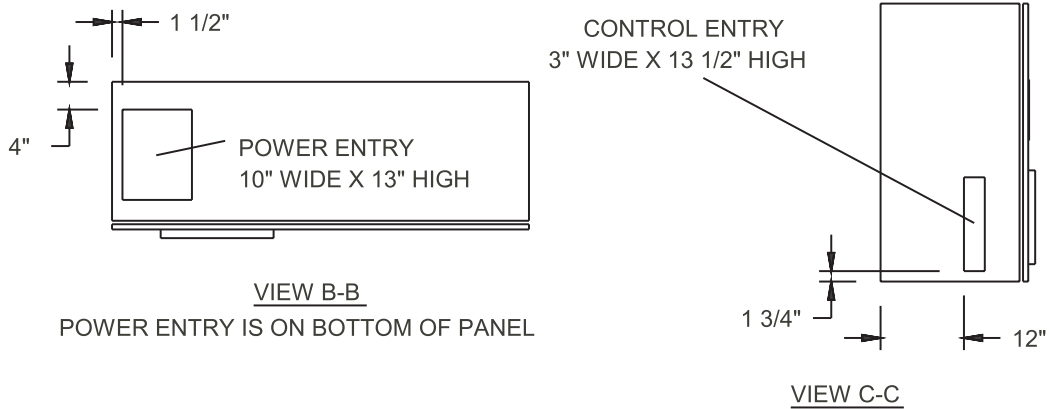

### Notes:

1. Placement on a level surface free of obstructions (including snow, for winter operation) or air recirculation ensure rated performance, reliable operation, and ease of maintenance. Site restrictions may compromise minimum clearances indicated below, resulting in unpredictable air patterns and possible diminished performance. Johnson Controls' unit controls will optimize the operation without nuisance high pressure safety cutouts; however, the system designer MUST consider potential performance degradation.
2. Access to the unit control center stipulates the unit is no higher when on spring isolators. Recommended minimum clearances: side to wall - 6'; rear to wall - 6'; control panel end to wall - 4'; top - no obstructions whatsoever; distance between adjacent units - 10'. No more than one adjacent wall may be higher than the unit.

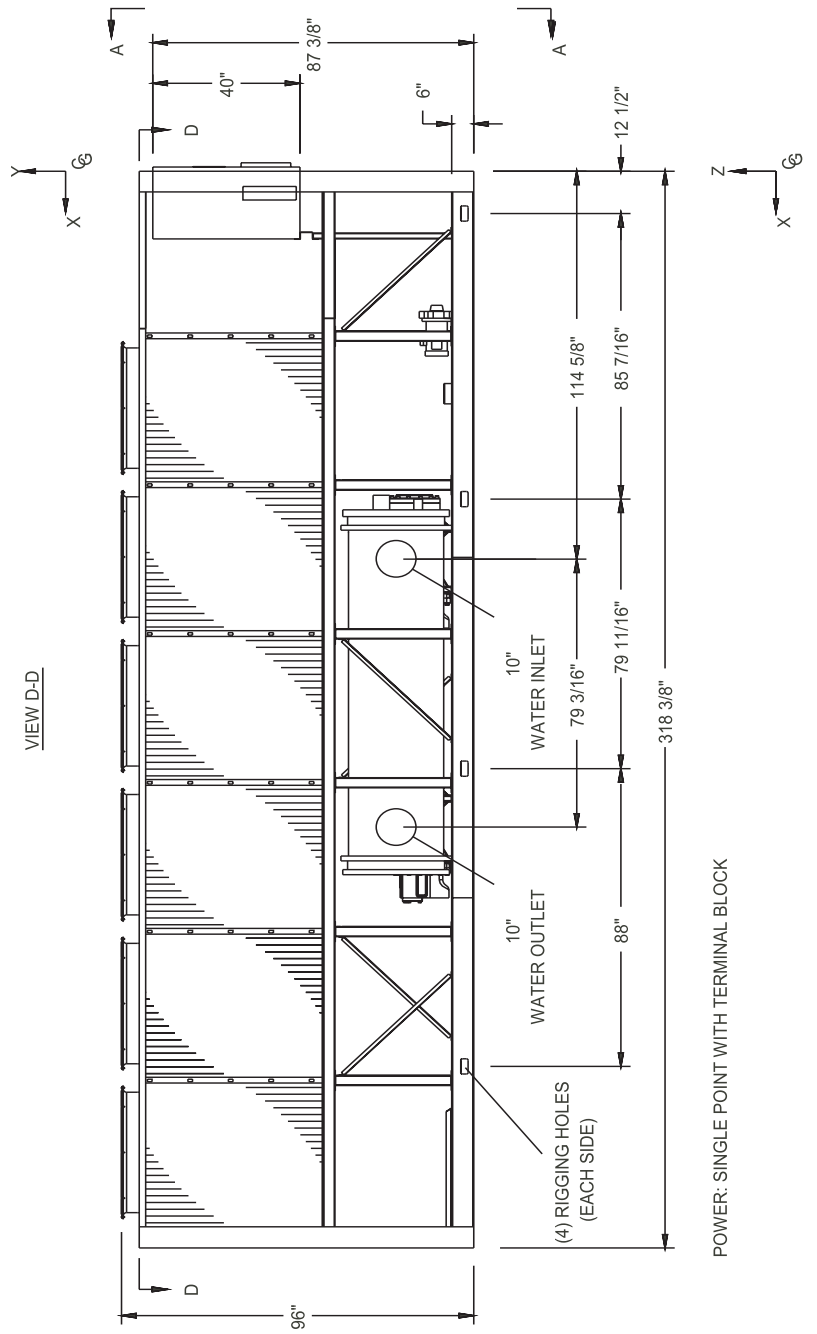
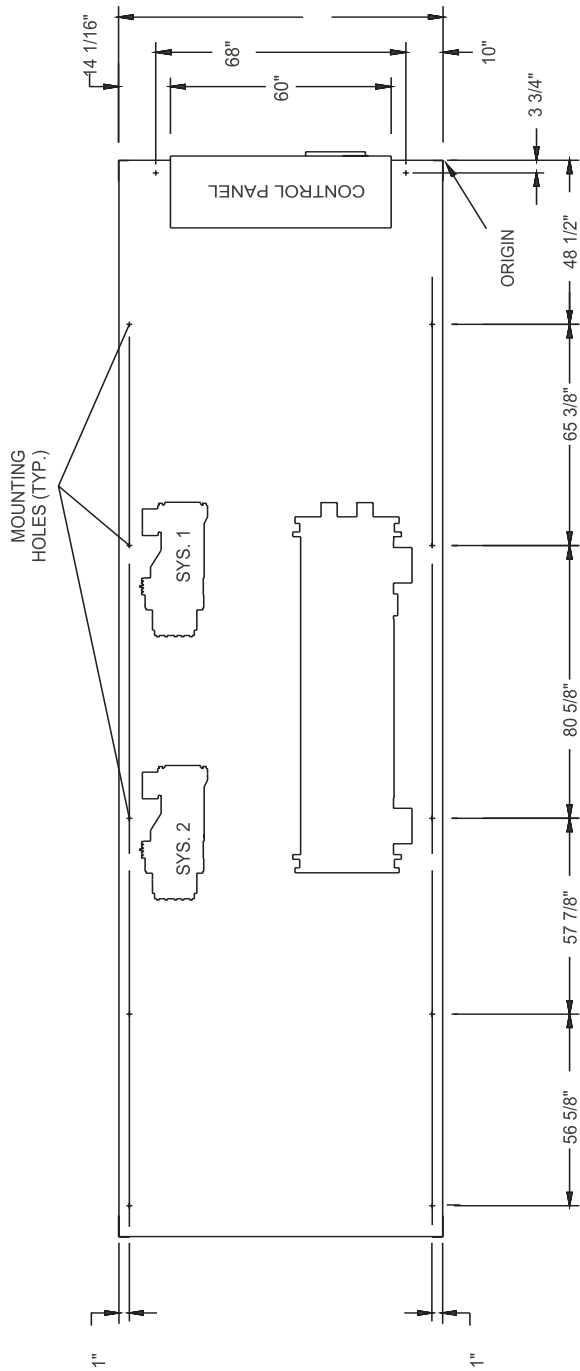

POWER: SINGLE POINT WITH TERMINAL BLOCK

# Dimensions - English - continued

## YCAV0267E/V, 0287S/P

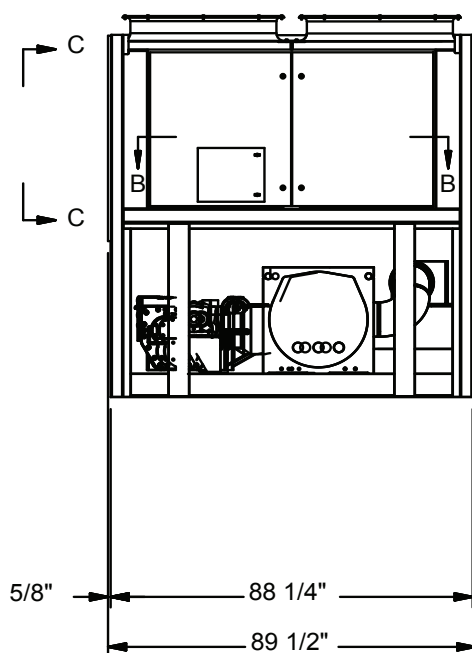
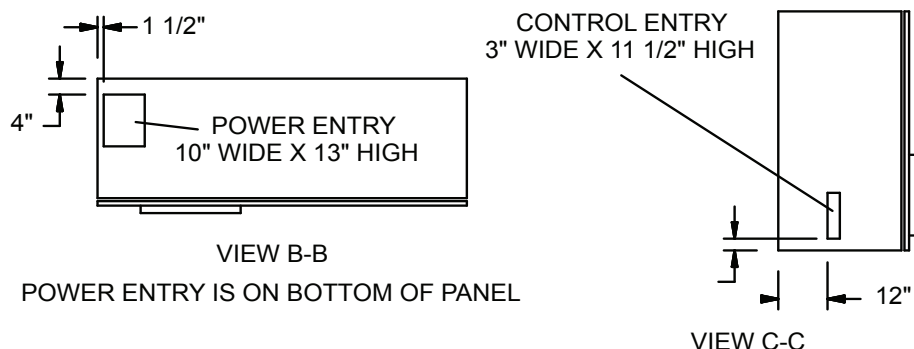

VIEW A-A  
POWER: SINGLE POINT WITH TERMINAL BLOCK

### Notes:

1. Placement on a level surface free of obstructions (including snow, for winter operation) or air recirculation ensure rated performance, reliable operation, and ease of maintenance. Site restrictions may compromise minimum clearances indicated below, resulting in unpredictable air patterns and possible diminished performance. Johnson Controls' unit controls will optimize the operation without nuisance high pressure safety cutouts; however, the system designer MUST consider potential performance degradation.
2. Access to the unit control center stipulates the unit is no higher when on spring isolators. Recommended minimum clearances: side to wall - 6'; rear to wall - 6'; control panel end to wall - 4'; top - no obstructions whatsoever; distance between adjacent units - 10'. No more than one adjacent wall may be higher than the unit.

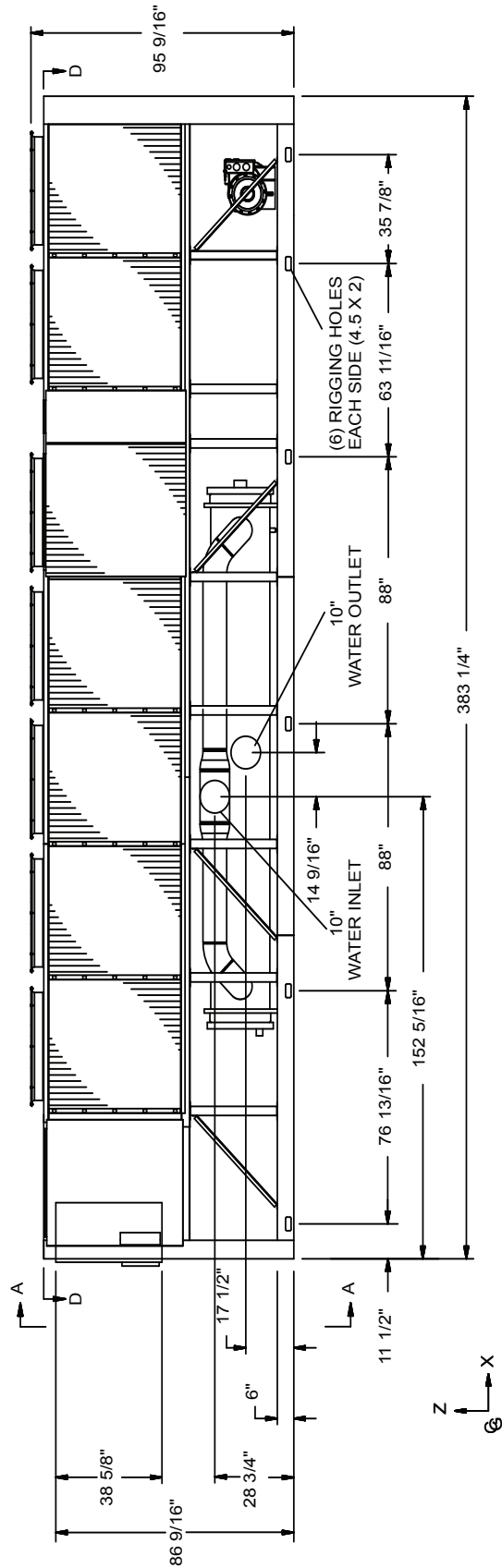
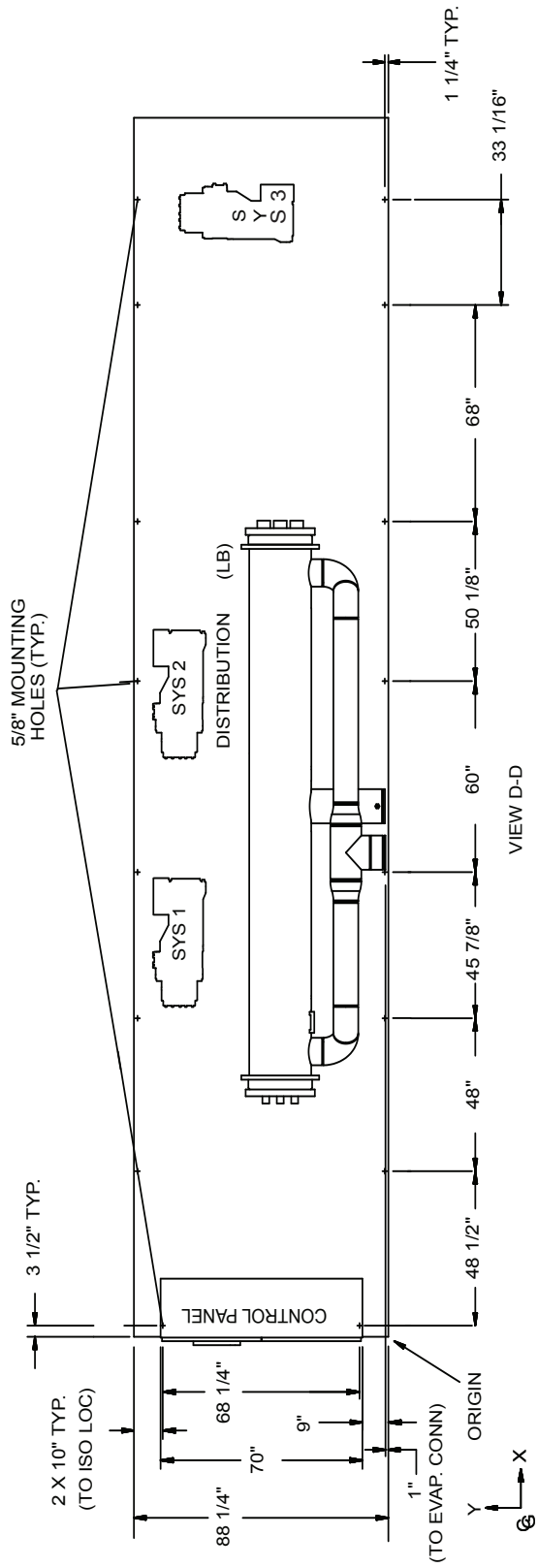

# Dimensions - English - continued

## YCAV0287E/V

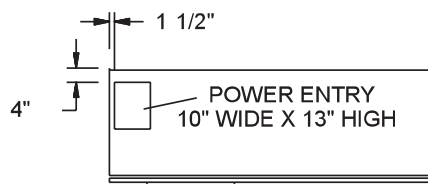

VIEW B-B  
POWER ENTRY IS ON BOTTOM OF PANEL

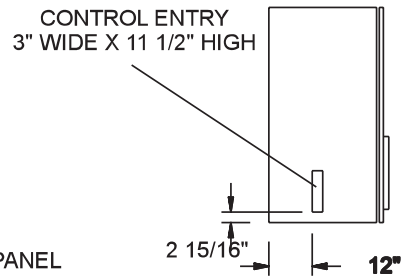

VIEW C-C

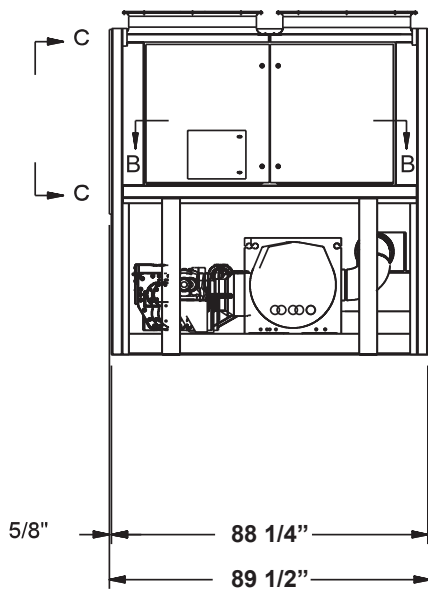

VIEW A-A

POWER: SINGLE POINT WITH TERMINAL BLOCK

### Notes:

1. Placement on a level surface free of obstructions (including snow, for winter operation) or air recirculation ensure rated performance, reliable operation, and ease of maintenance. Site restrictions may compromise minimum clearances indicated below, resulting in unpredictable air patterns and possible diminished performance. Johnson Controls' unit controls will optimize the operation without nuisance high pressure safety cutouts; however, the system designer MUST consider potential performance degradation.
2. Access to the unit control center stipulates the unit is no higher when on spring isolators. Recommended minimum clearances: side to wall - 6"; rear to wall - 6"; control panel end to wall - 4"; top - no obstructions whatsoever; distance between adjacent units - 10'. No more than one adjacent wall may be higher than the unit.



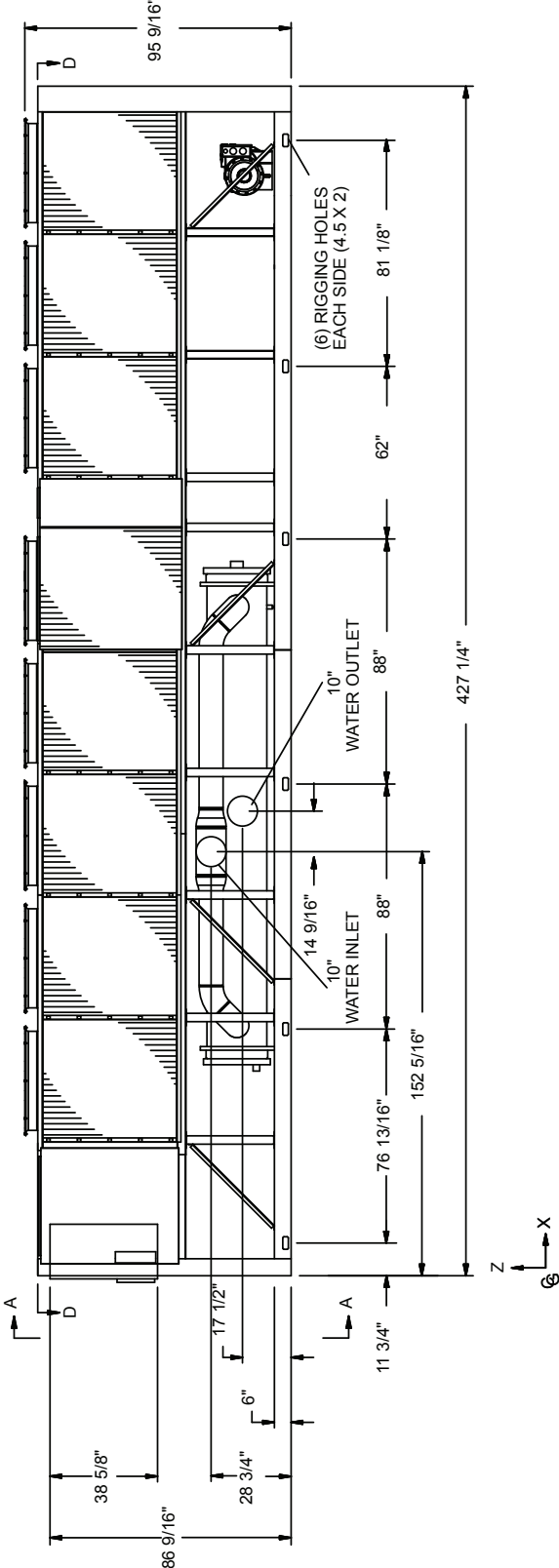
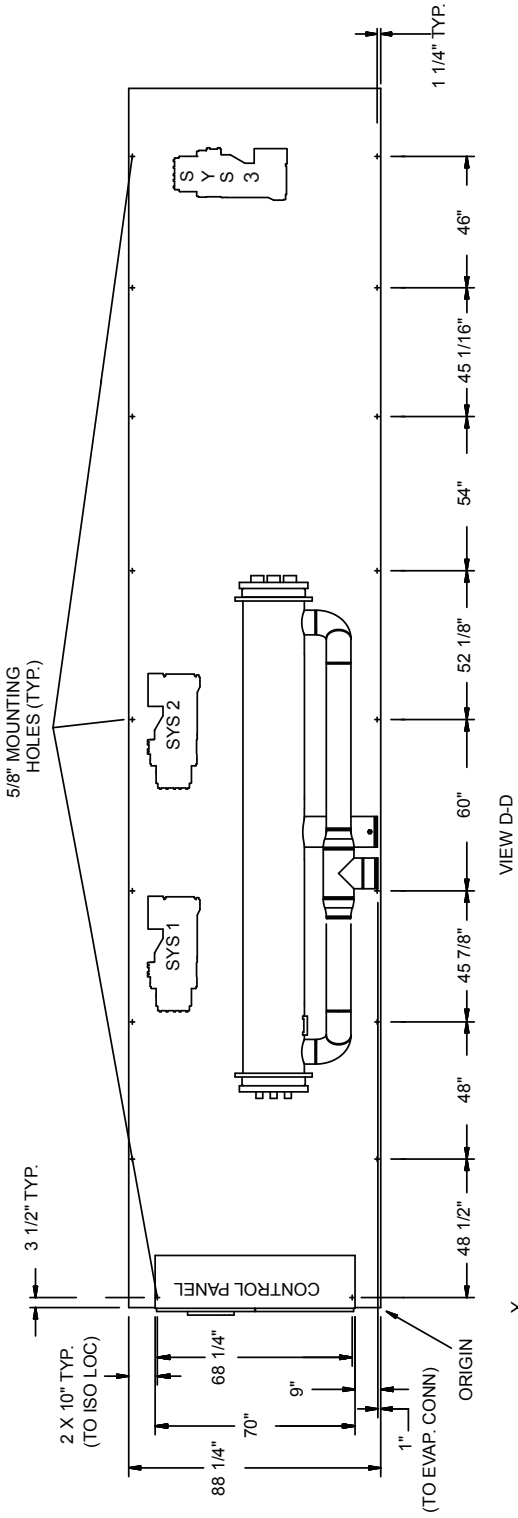

# Dimensions - English - continued

## YCAV0307S/P

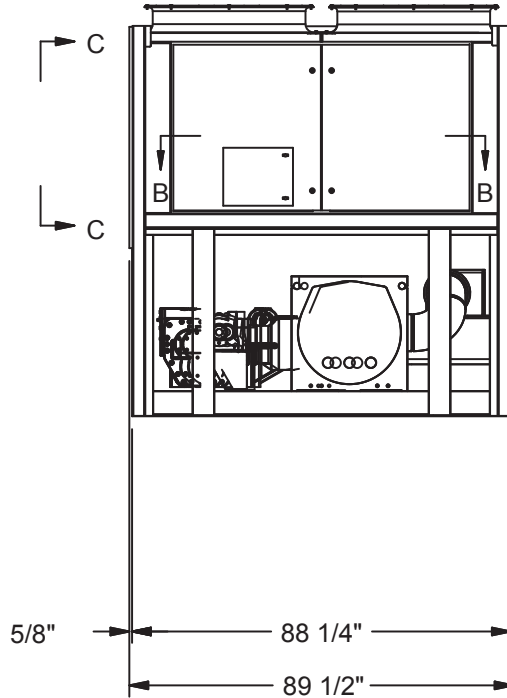
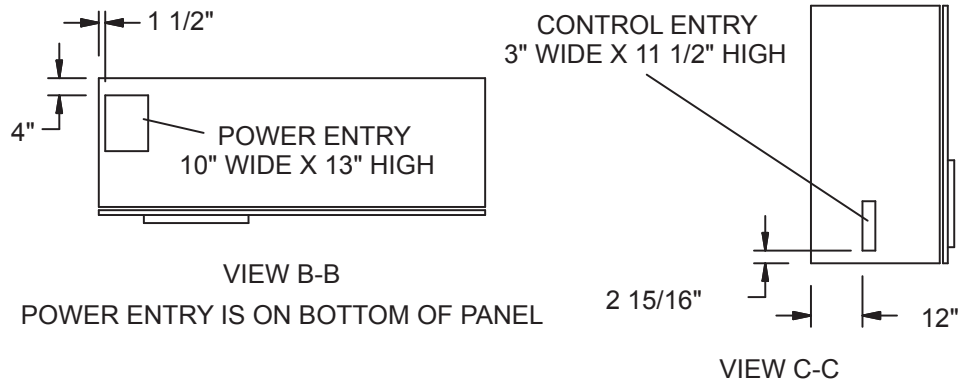

### Notes:

1. Placement on a level surface free of obstructions (including snow, for winter operation) or air recirculation ensure rated performance, reliable operation, and ease of maintenance. Site restrictions may compromise minimum clearances indicated below, resulting in unpredictable air patterns and possible diminished performance. Johnson Controls' unit controls will optimize the operation without nuisance high pressure safety cutouts; however, the system designer MUST consider potential performance degradation.
2. Access to the unit control center stipulates the unit is no higher when on spring isolators. Recommended minimum clearances: side to wall - 6'; rear to wall - 6'; control panel end to wall - 4'; top - no obstructions whatsoever; distance between adjacent units - 10'. No more than one adjacent wall may be higher than the unit.

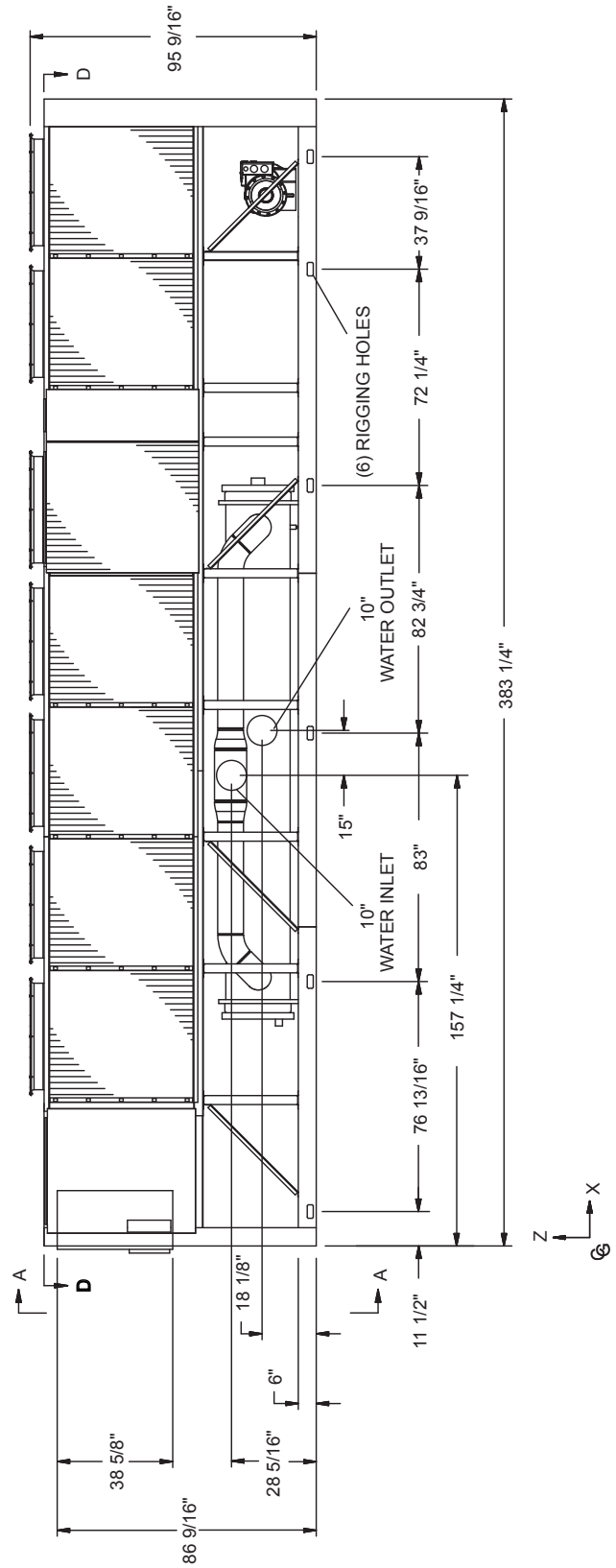
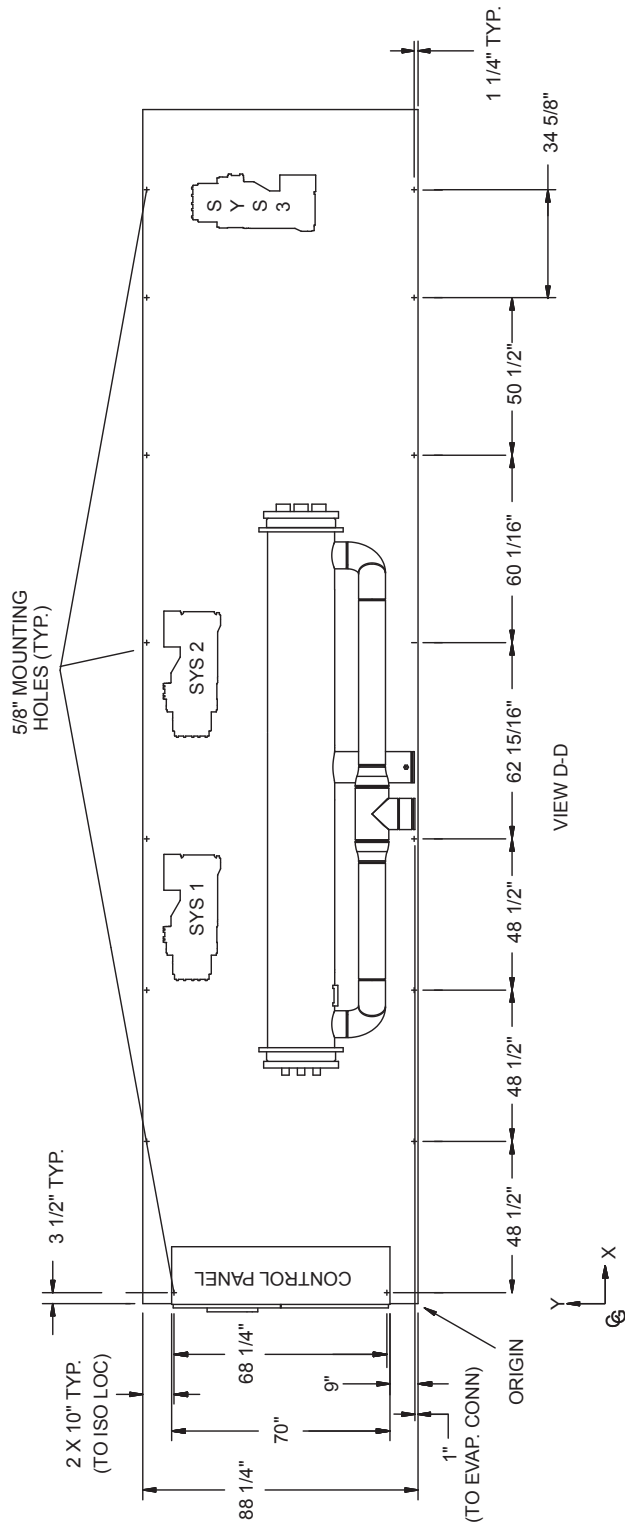

# Dimensions - English - continued

## YCAV0327E/V, 0357S/P

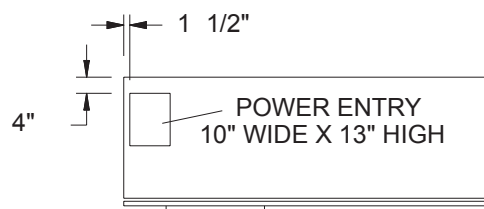

VIEW B-B  
POWER ENTRY IS ON BOTTOM OF PANEL

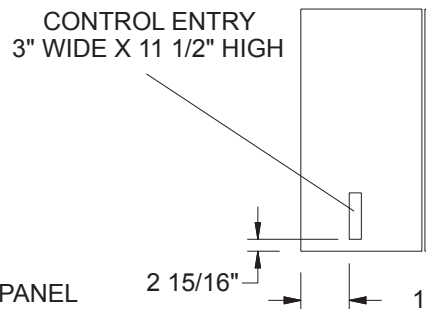

VIEW C-C

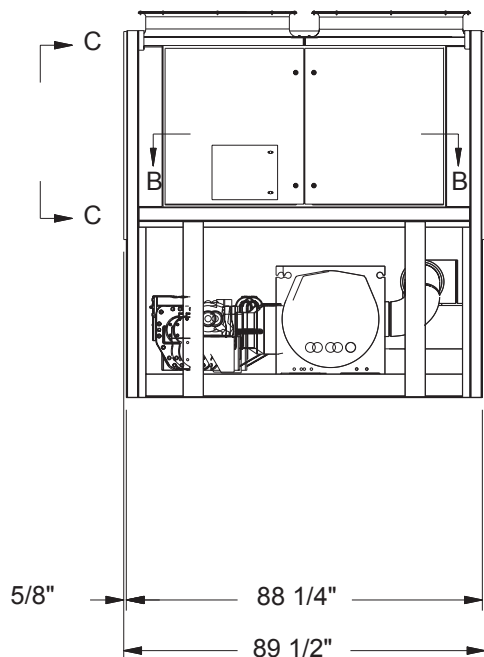

VIEW A-A  
POWER: SINGLE POINT WITH TERMINAL BLOCK

### Notes:

1. Placement on a level surface free of obstructions (including snow, for winter operation) or air recirculation ensure rated performance, reliable operation, and ease of maintenance. Site restrictions may compromise minimum clearances indicated below, resulting in unpredictable air patterns and possible diminished performance. Johnson Controls' unit controls will optimize the operation without nuisance high pressure safety cutouts; however, the system designer MUST consider potential performance degradation.
2. Access to the unit control center stipulates the unit is no higher when on spring isolators. Recommended minimum clearances: side to wall - 6"; rear to wall - 6"; control panel end to wall - 4"; top - no obstructions whatsoever; distance between adjacent units - 10'. No more than one adjacent wall may be higher than the unit.

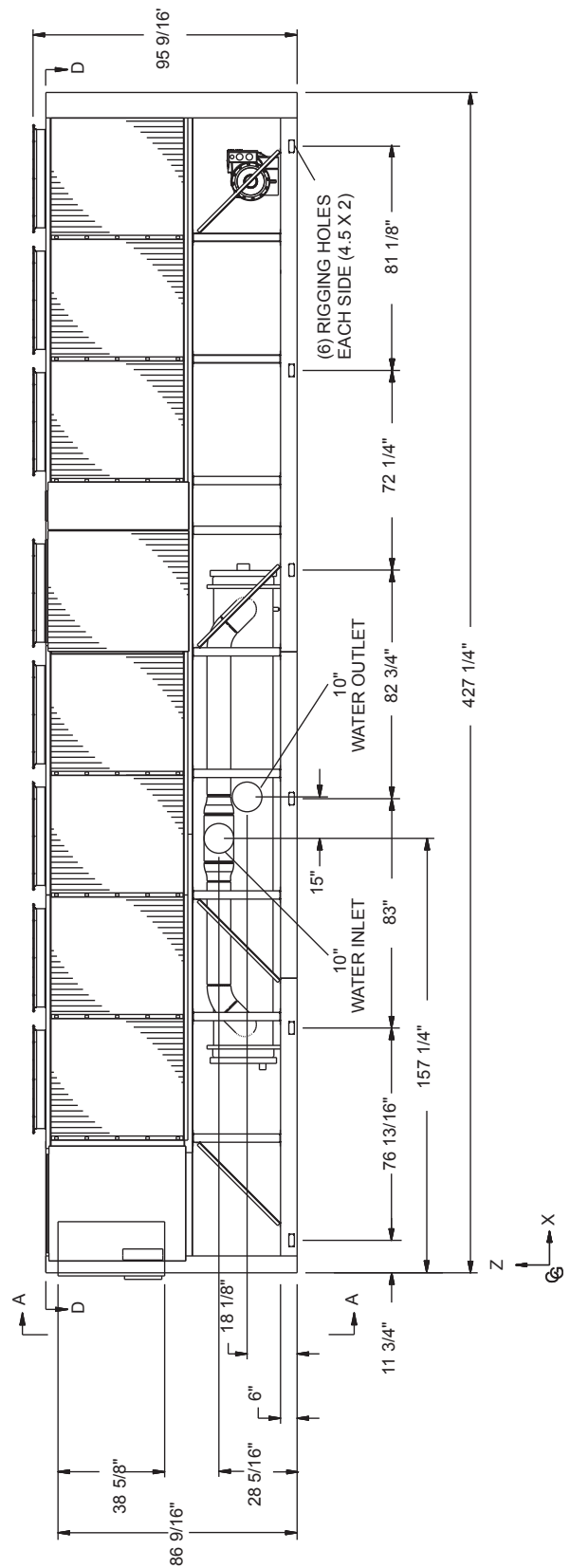
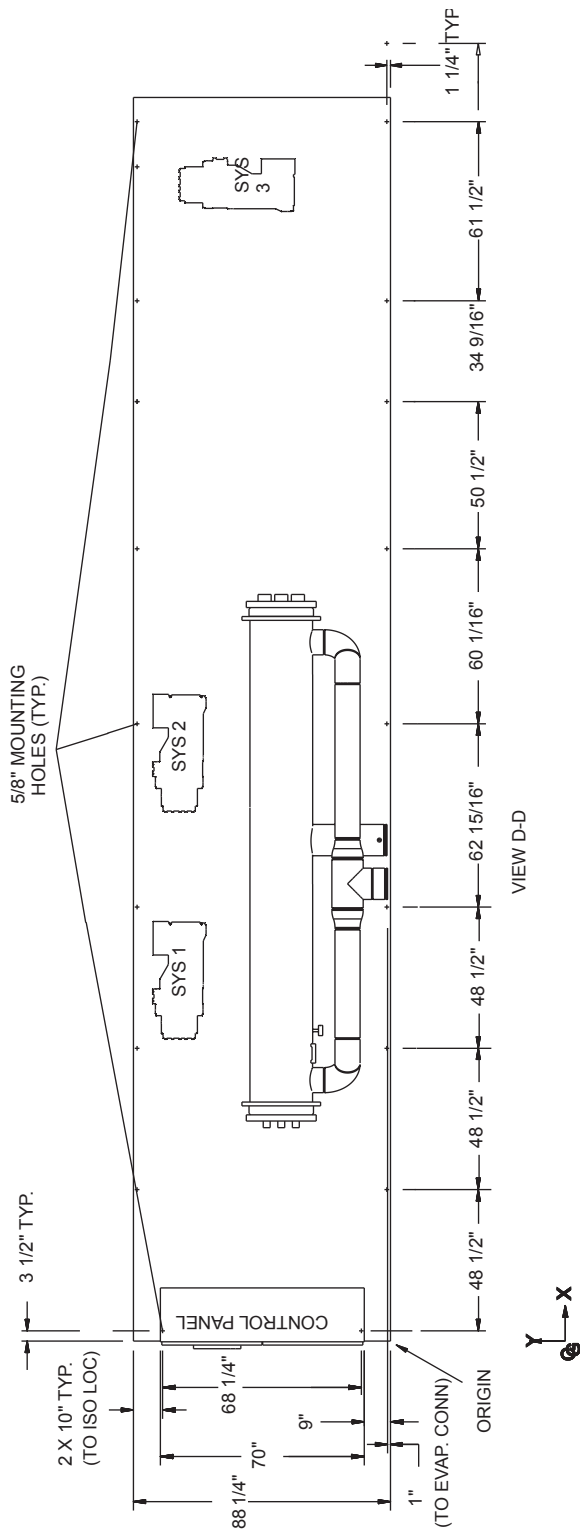

# Dimensions - English - continued

## YCAV0357E/V, 0397S/P

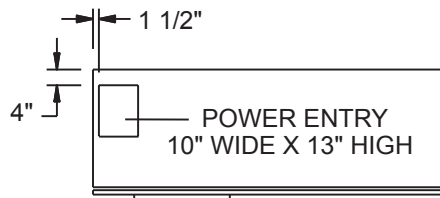

VIEW B-B  
POWER ENTRY IS ON BOTTOM OF PANEL

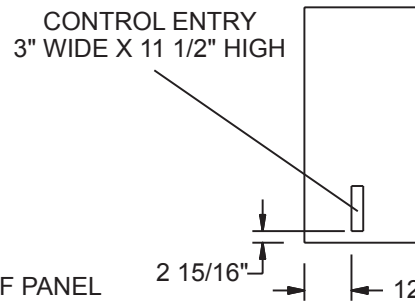

VIEW C-C

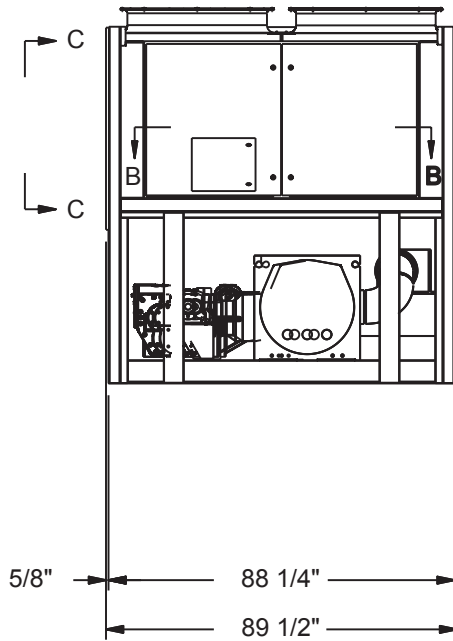

VIEW A-A

POWER: SINGLE POINT WITH TERMINAL BLOCK

### Notes:

1. Placement on a level surface free of obstructions (including snow, for winter operation) or air recirculation ensure rated performance, reliable operation, and ease of maintenance. Site restrictions may compromise minimum clearances indicated below, resulting in unpredictable air patterns and possible diminished performance. Johnson Controls' unit controls will optimize the operation without nuisance high pressure safety cutouts; however, the system designer MUST consider potential performance degradation.
2. Access to the unit control center stipulates the unit is no higher when on spring isolators. Recommended minimum clearances: side to wall - 6'; rear to wall - 6'; control panel end to wall - 4'; top - no obstructions whatsoever; distance between adjacent units - 10'. No more than one adjacent wall may be higher than the unit.

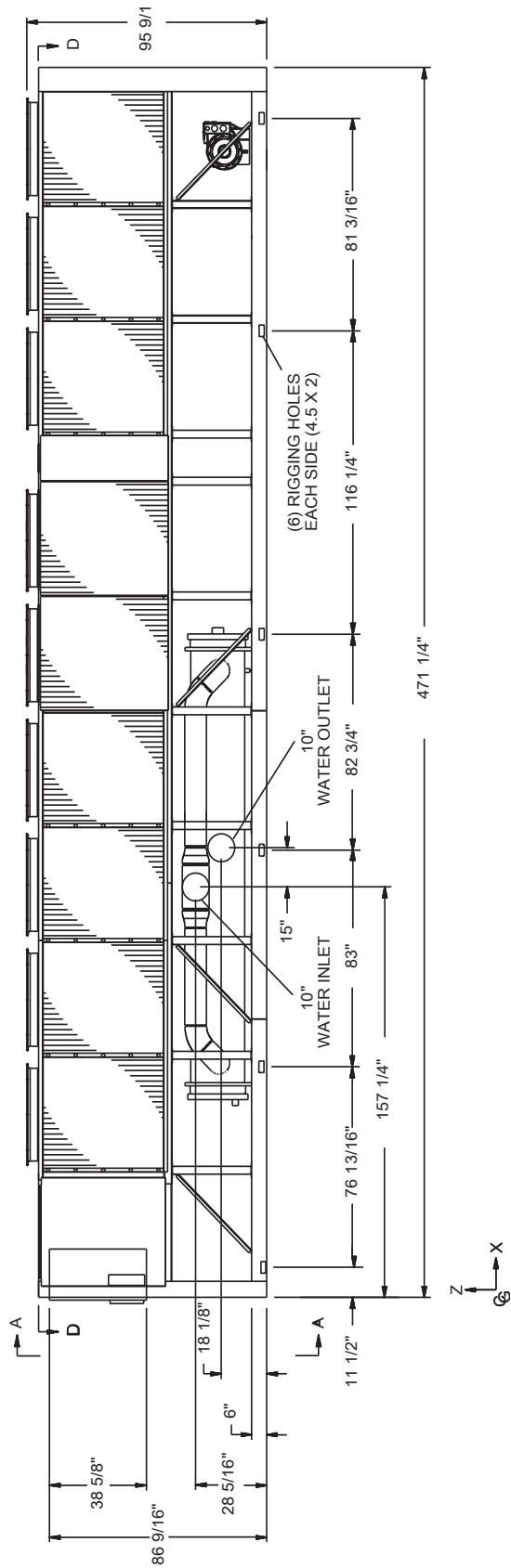
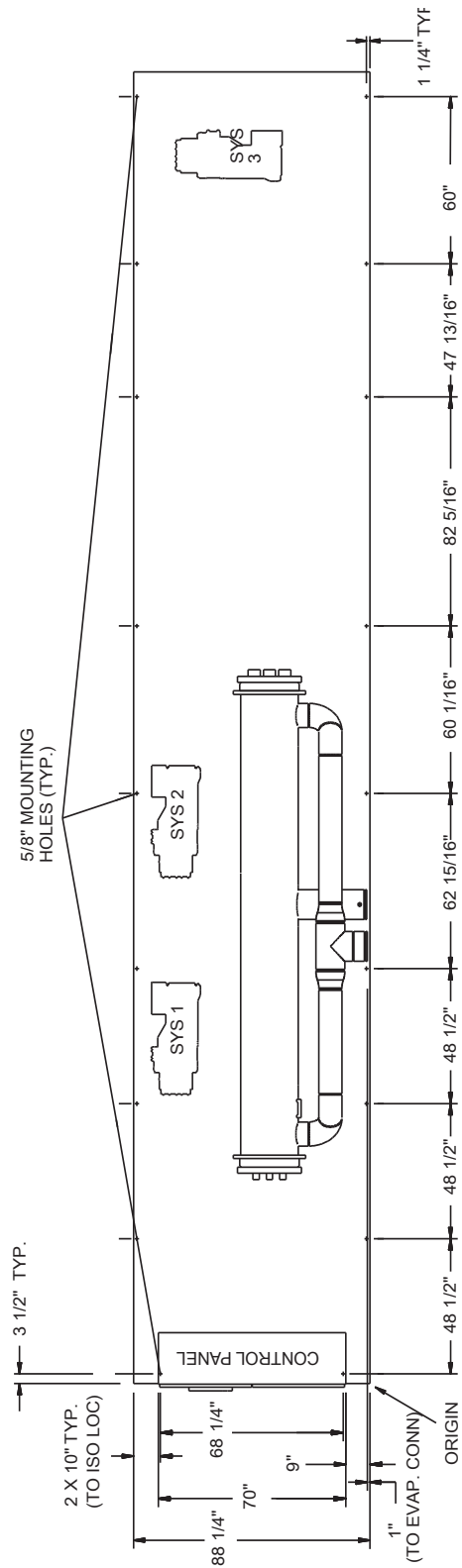

# Dimensions - English - continued

## YCAV0397E/V, 0417S/P, 1429E/V, 1549S/P

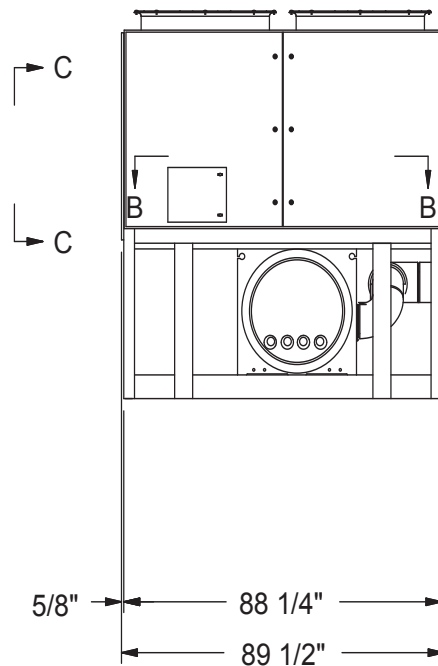
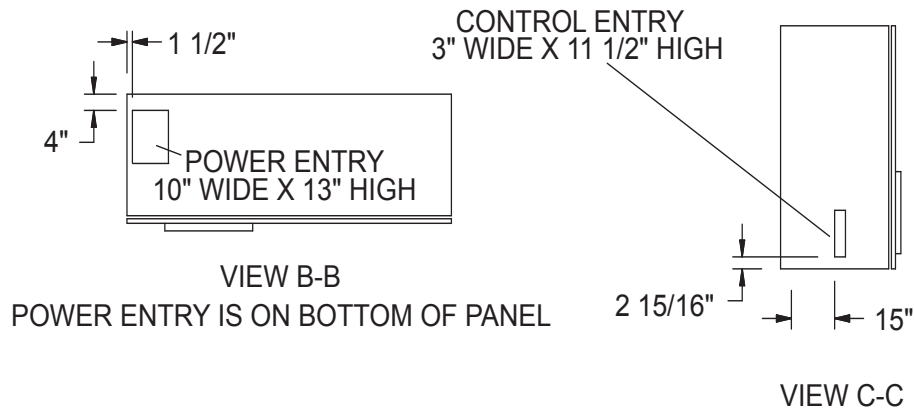

VIEW A-A

### Notes:

1. Placement on a level surface free of obstructions (including snow, for winter operation) or air recirculation ensure rated performance, reliable operation, and ease of maintenance. Site restrictions may compromise minimum clearances indicated below, resulting in unpredictable air patterns and possible diminished performance. Johnson Controls' unit controls will optimize the operation without nuisance high pressure safety cutouts; however, the system designer MUST consider potential performance degradation.
2. Access to the unit control center stipulates the unit is no higher when on spring isolators. Recommended minimum clearances: side to wall - 6'; rear to wall - 6'; control panel end to wall - 4'; top - no obstructions whatsoever; distance between adjacent units - 10'. No more than one adjacent wall may be higher than the unit.



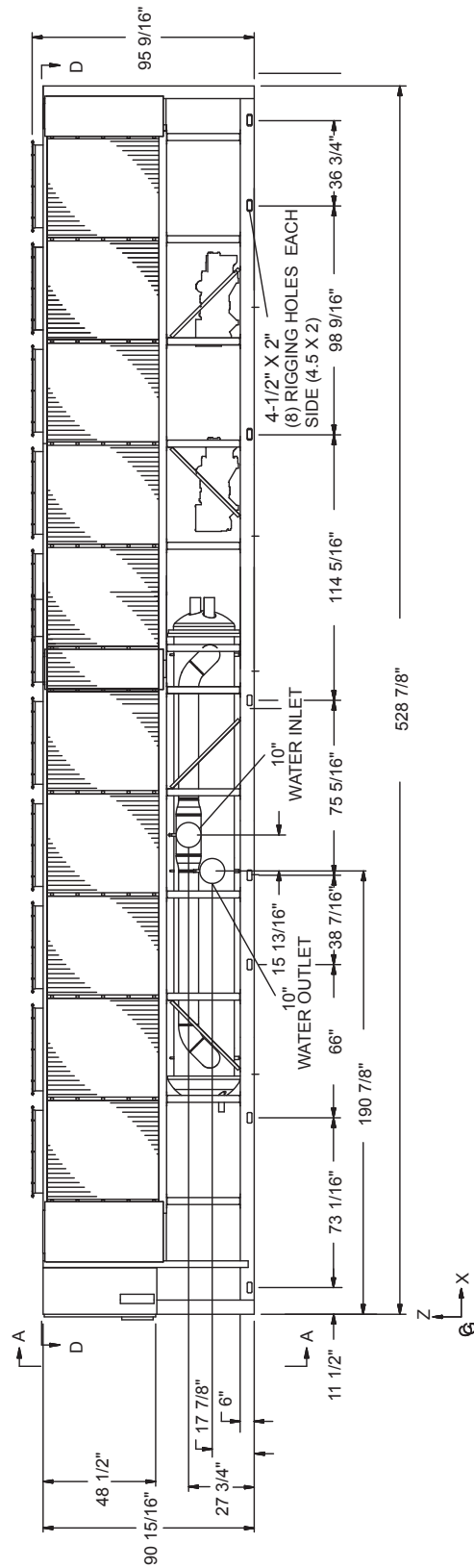
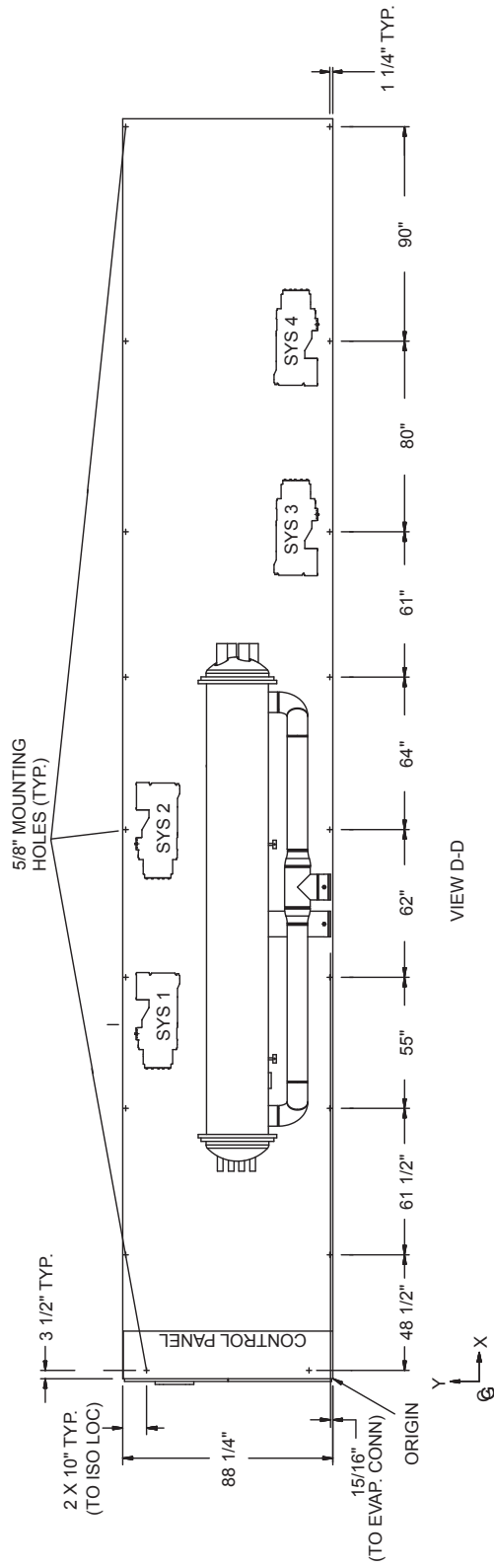

# Dimensions - English - continued

## YCAV0417E/V, 0477S/P, 1549E/V, 1739S/P

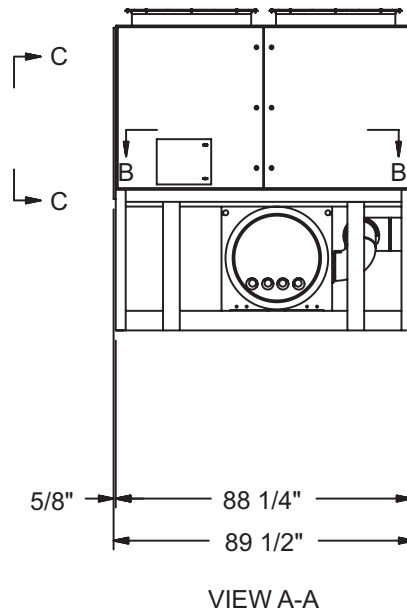
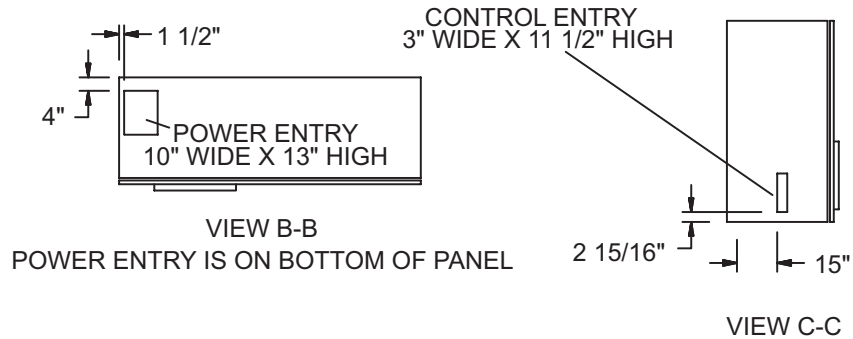

### Notes:

1. Placement on a level surface free of obstructions (including snow, for winter operation) or air recirculation ensure rated performance, reliable operation, and ease of maintenance. Site restrictions may compromise minimum clearances indicated below, resulting in unpredictable air patterns and possible diminished performance. Johnson Controls' unit controls will optimize the operation without nuisance high pressure safety cutouts; however, the system designer MUST consider potential performance degradation.
2. Access to the unit control center stipulates the unit is no higher when on spring isolators. Recommended minimum clearances: side to wall - 6'; rear to wall - 6'; control panel end to wall - 4'; top - no obstructions whatsoever; distance between adjacent units - 10'. No more than one adjacent wall may be higher than the unit.

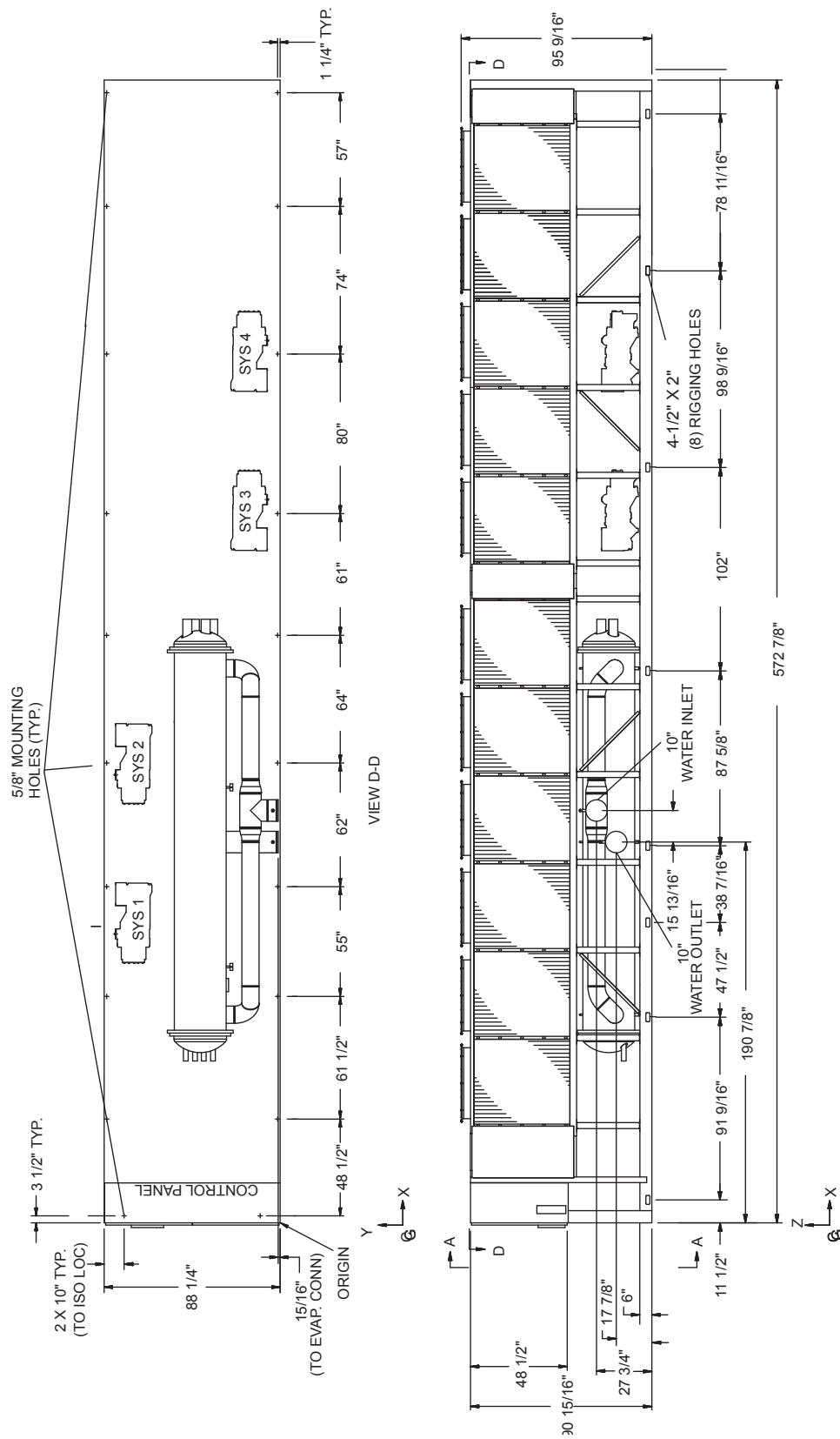

# Dimensions - English - continued

## YCAV0457S/P, 1649S/P

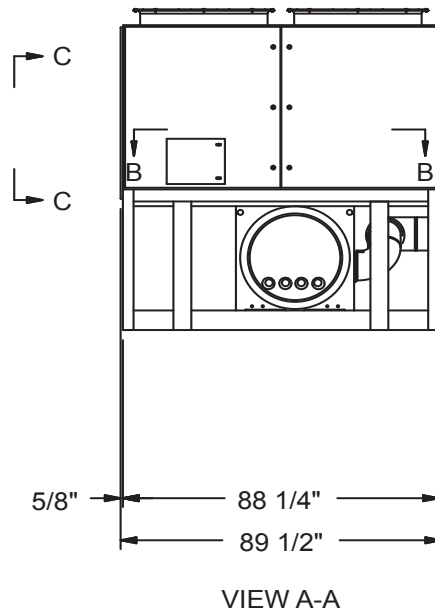
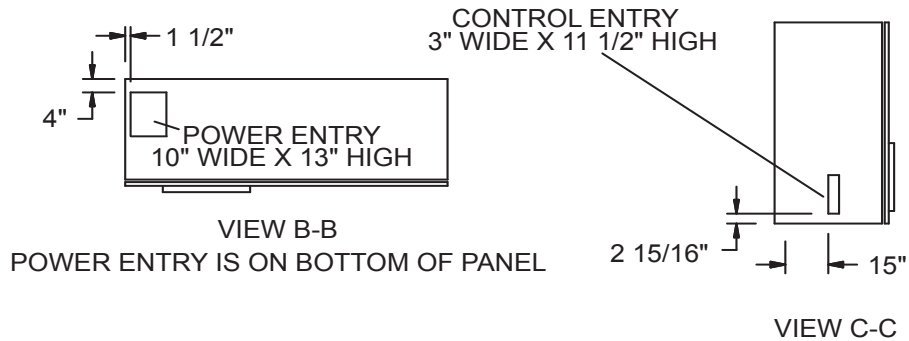

### Notes:

1. Placement on a level surface free of obstructions (including snow, for winter operation) or air recirculation ensure rated performance, reliable operation, and ease of maintenance. Site restrictions may compromise minimum clearances indicated below, resulting in unpredictable air patterns and possible diminished performance. Johnson Controls' unit controls will optimize the operation without nuisance high pressure safety cutouts; however, the system designer MUST consider potential performance degradation.
2. Access to the unit control center stipulates the unit is no higher when on spring isolators. Recommended minimum clearances: side to wall - 6'; rear to wall - 6'; control panel end to wall - 4'; top - no obstructions whatsoever; distance between adjacent units - 10'. No more than one adjacent wall may be higher than the unit.

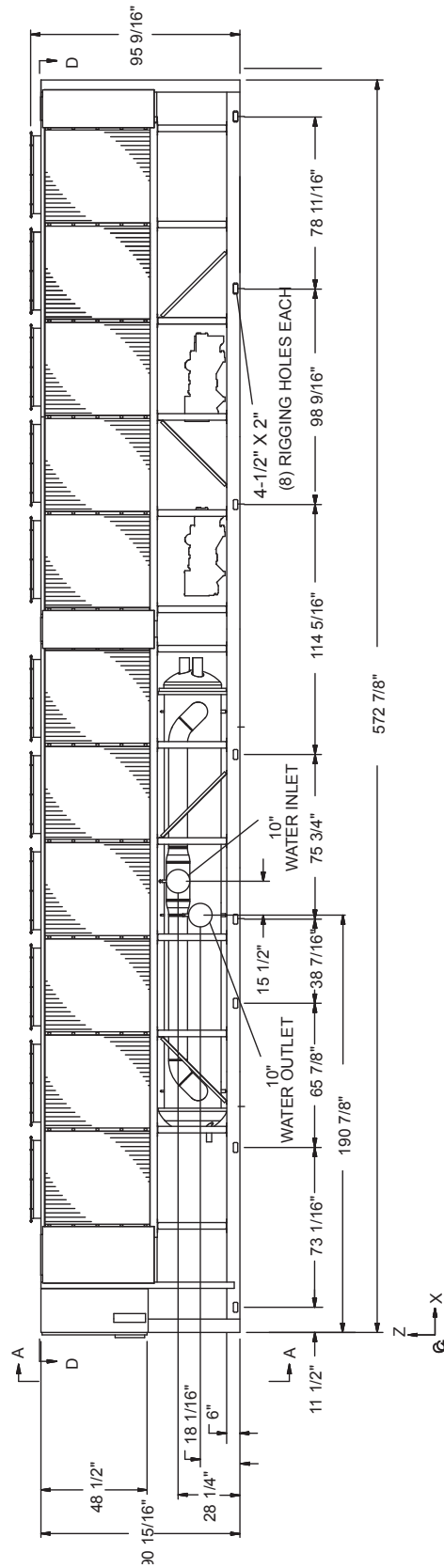
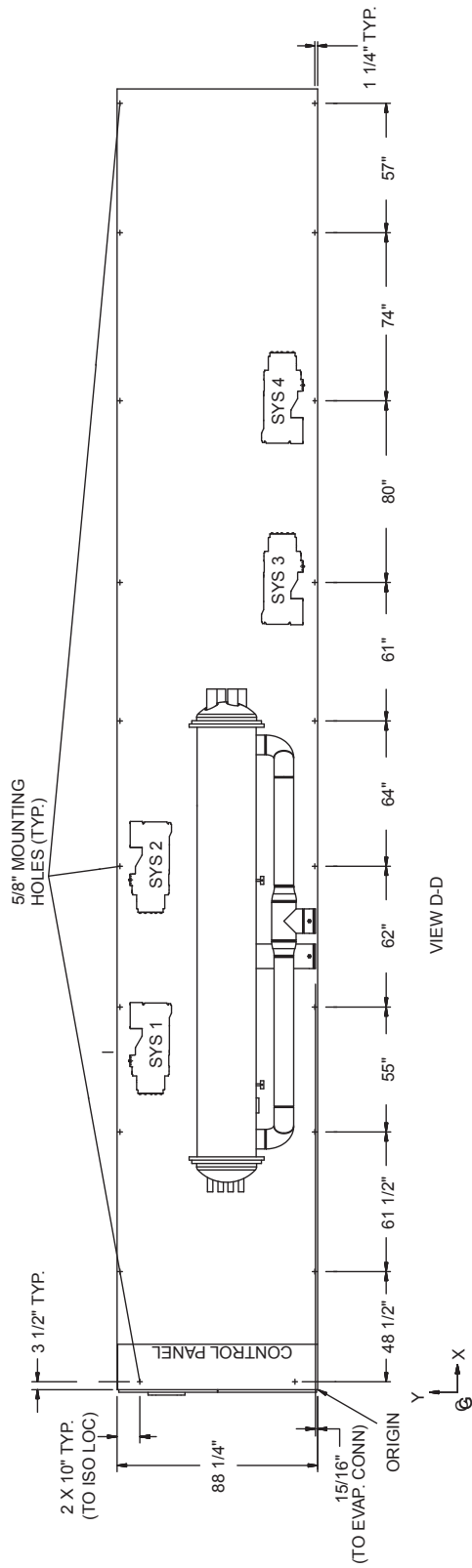

# Dimensions - English - continued

**YCAV0477E/V, 0507S/P, 0527S/P, 1739E/V, 1829S/P, 1909S/P**

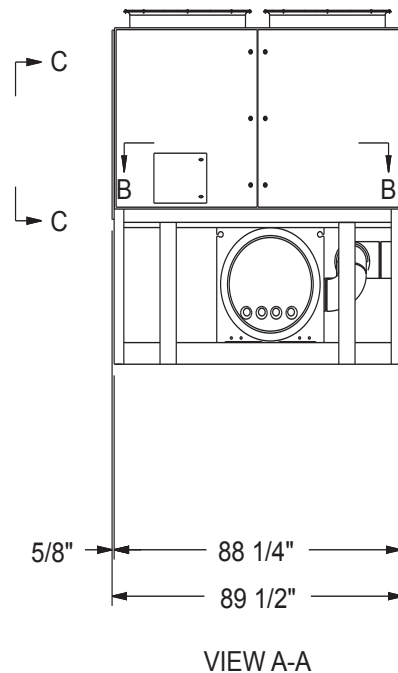
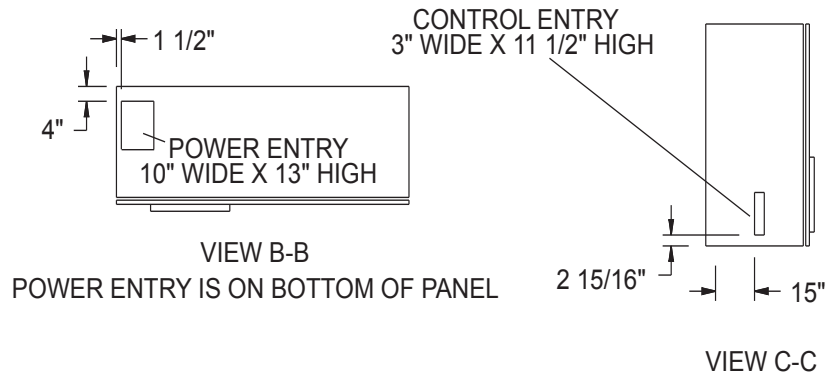

**Notes:**

1. Placement on a level surface free of obstructions (including snow, for winter operation) or air recirculation ensure rated performance, reliable operation, and ease of maintenance. Site restrictions may compromise minimum clearances indicated below, resulting in unpredictable air patterns and possible diminished performance. Johnson Controls' unit controls will optimize the operation without nuisance high pressure safety cutouts; however, the system designer MUST consider potential performance degradation.
2. Access to the unit control center stipulates the unit is no higher when on spring isolators. Recommended minimum clearances: side to wall - 6'; rear to wall - 6'; control panel end to wall - 4'; top - no obstructions whatsoever; distance between adjacent units - 10'. No more than one adjacent wall may be higher than the unit.

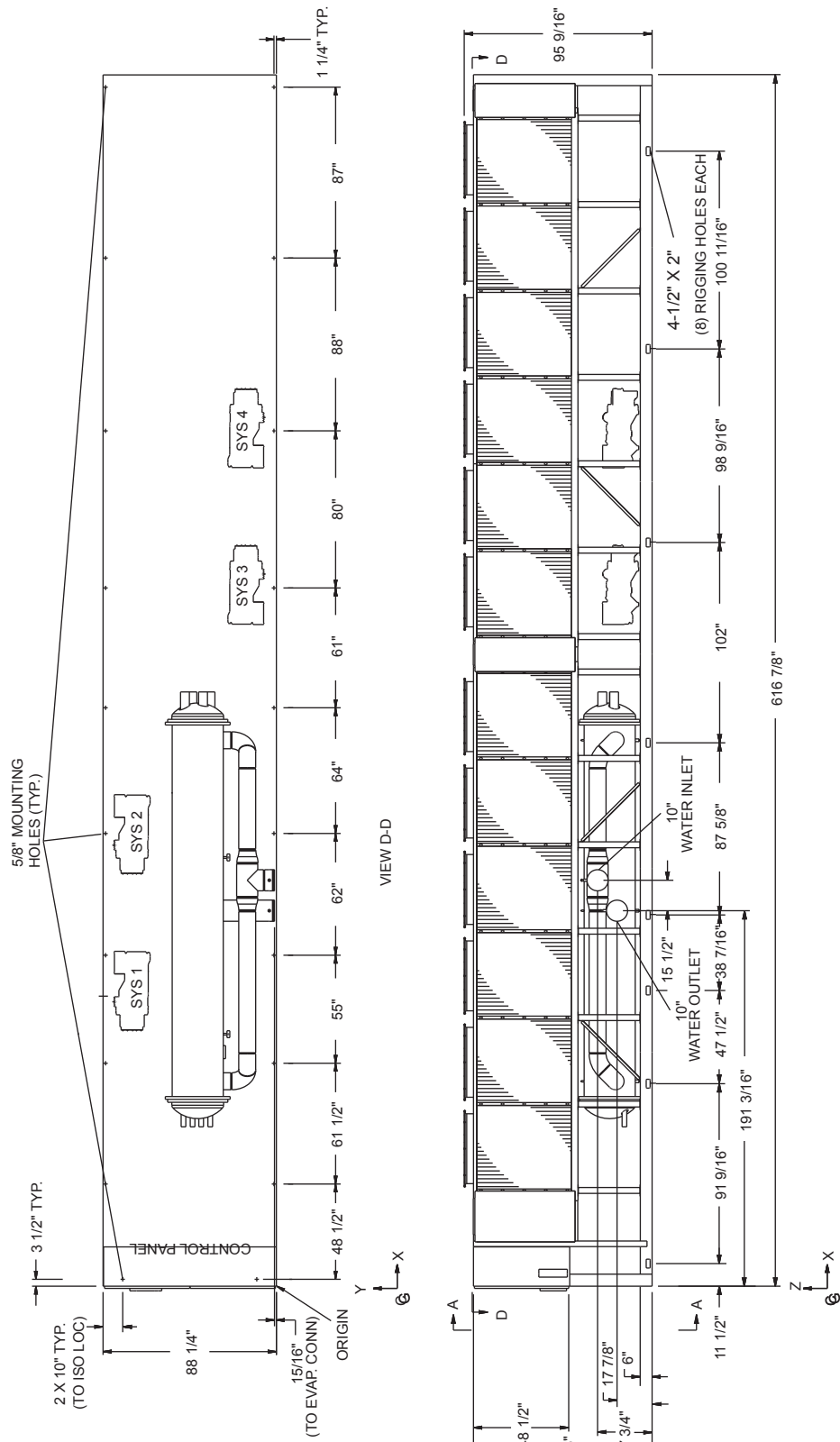

# Dimensions - SI

## YCAV0157S/P

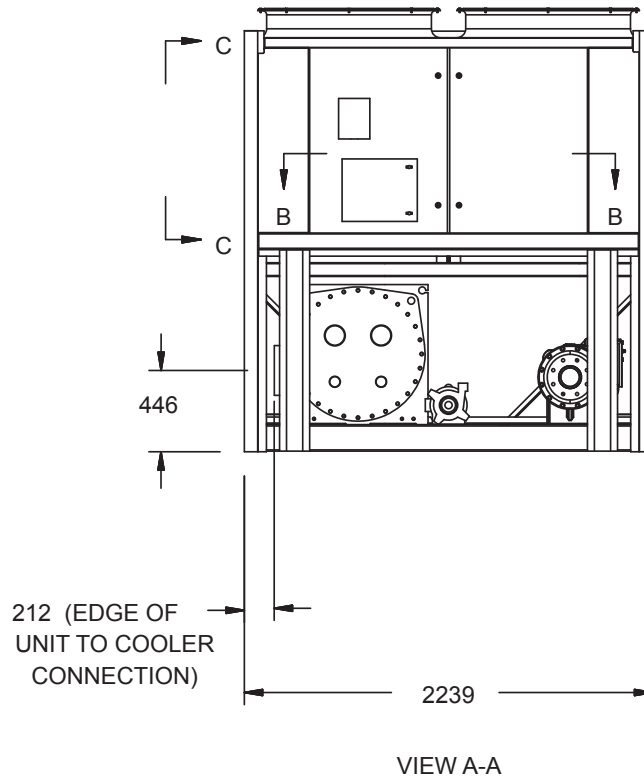
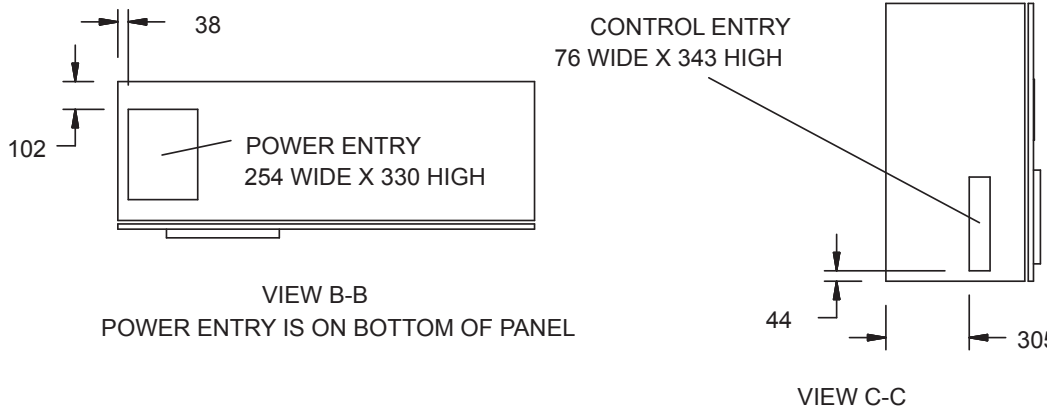

### Notes:

1. Placement on a level surface free of obstructions (including snow, for winter operation) or air recirculation ensure rated performance, reliable operation, and ease of maintenance. Site restrictions may compromise minimum clearances indicated below, resulting in unpredictable air patterns and possible diminished performance. Johnson Controls' unit controls will optimize the operation without nuisance high pressure safety cutouts; however, the system designer **MUST** consider potential performance degradation.
2. Access to the unit control center stipulates the unit is no higher when on spring isolators. Recommended minimum clearances: side to wall - 2m; rear to wall - 2m control panel end to wall - 1.2m; top - no obstructions whatsoever; distance between adjacent units - 3m. No more than one adjacent wall may be higher than the unit.



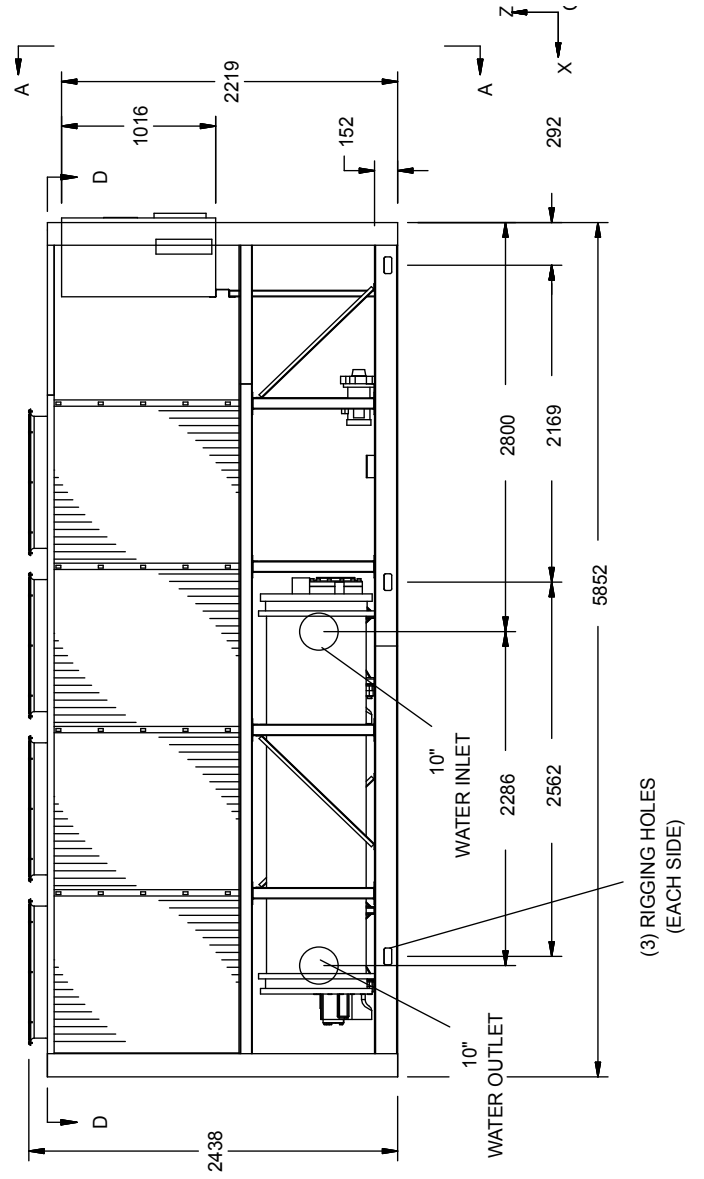
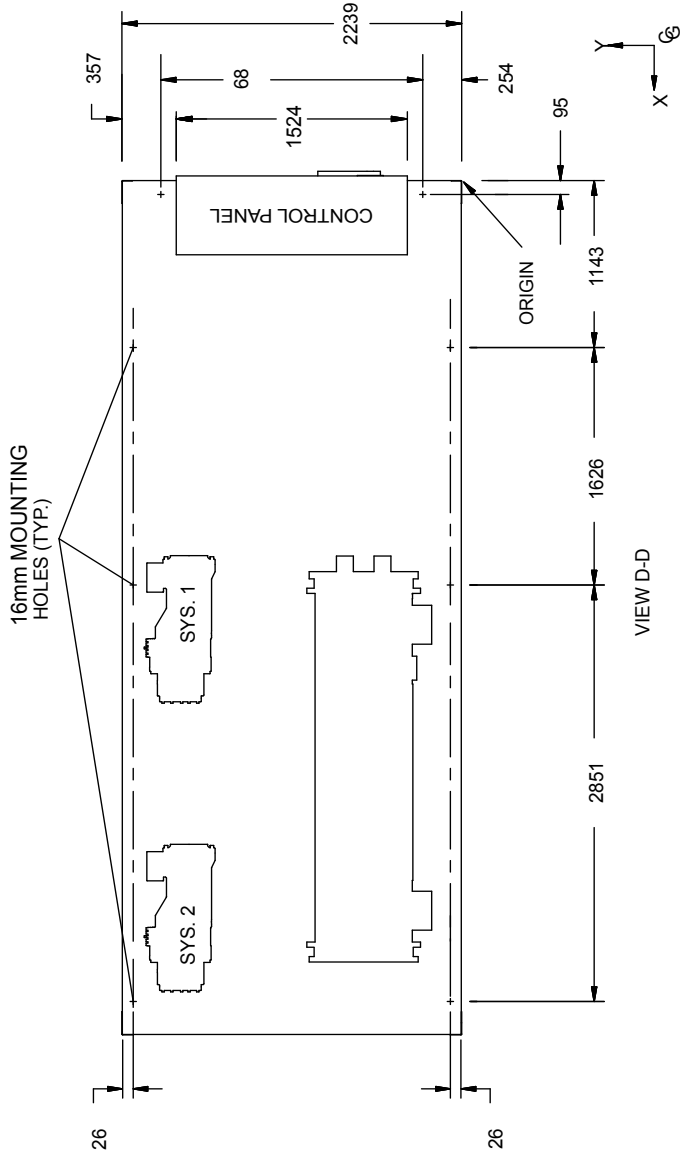

# Dimensions - SI - continued

## YCAV0157E/V, 0177S/P

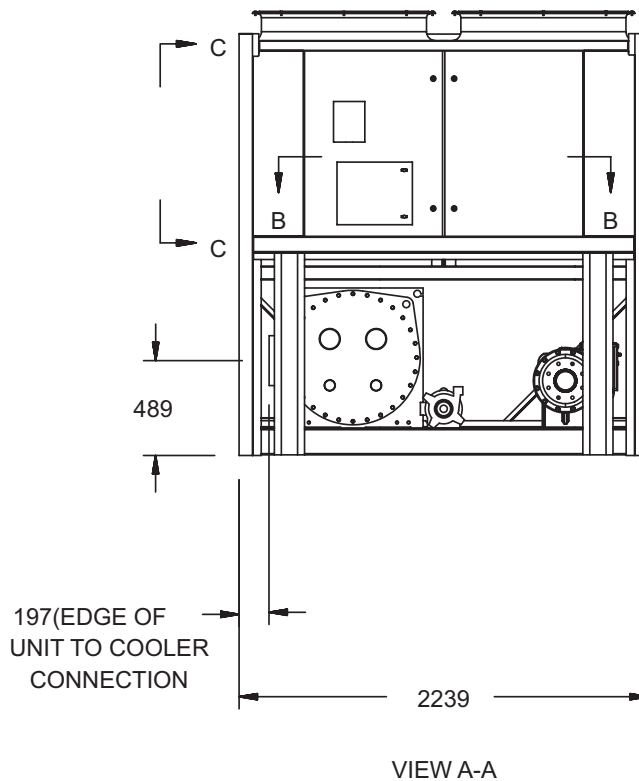
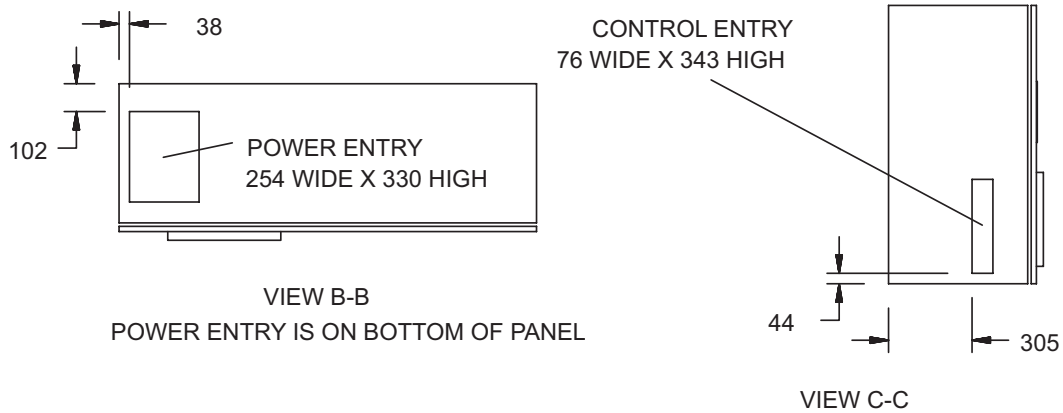

### Notes:

1. Placement on a level surface free of obstructions (including snow, for winter operation) or air recirculation ensure rated performance, reliable operation, and ease of maintenance. Site restrictions may compromise minimum clearances indicated below, resulting in unpredictable air patterns and possible diminished performance. Johnson Controls' unit controls will optimize the operation without nuisance high pressure safety cutouts; however, the system designer **MUST** consider potential performance degradation.
2. Access to the unit control center stipulates the unit is no higher when on spring isolators. Recommended minimum clearances: side to wall - 2m; rear to wall - 2m control panel end to wall - 1.2m; top - no obstructions whatsoever; distance between adjacent units - 3m. No more than one adjacent wall may be higher than the unit.

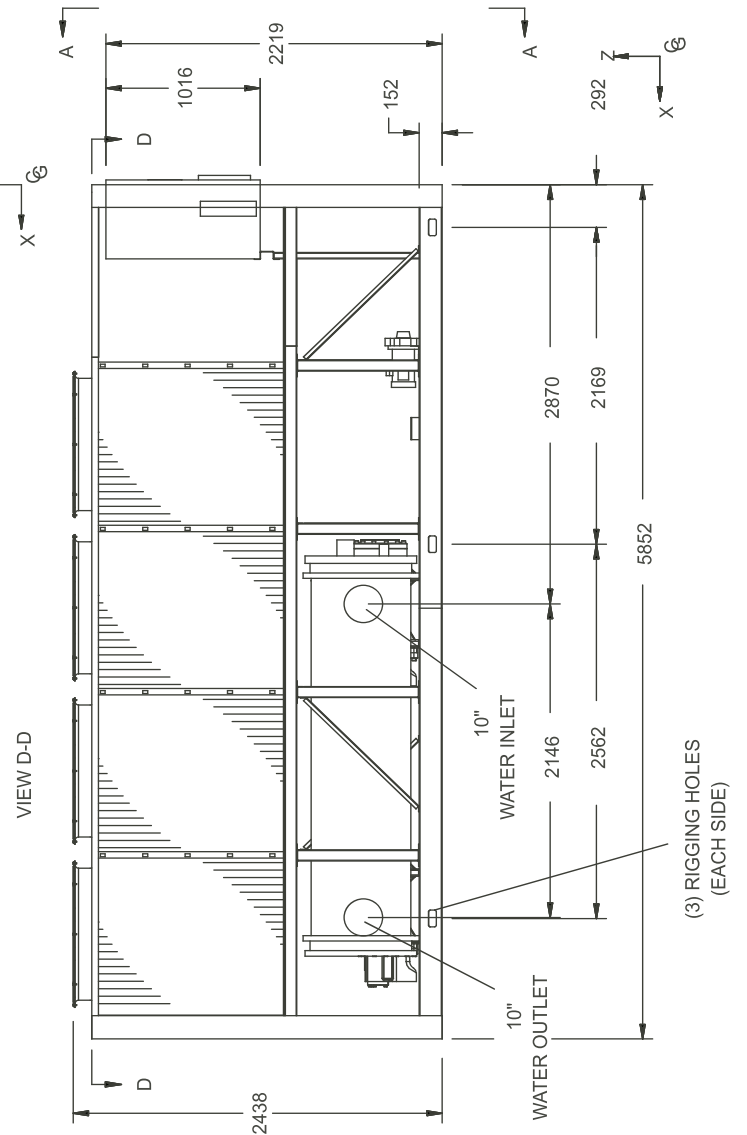
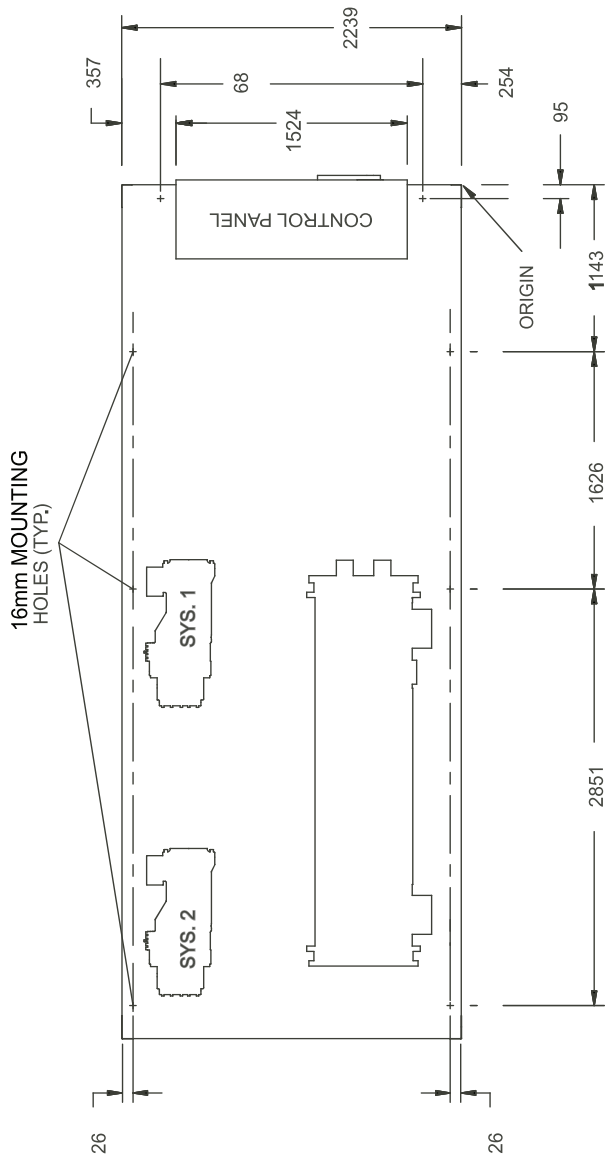

# Dimensions - SI - continued

## YCAV0177E/V, 0187S/P, 0187E/V

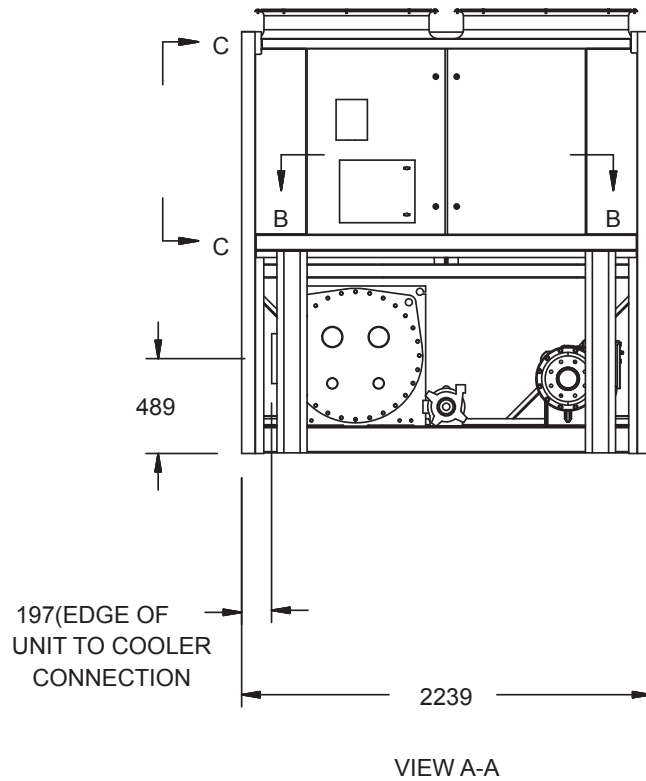
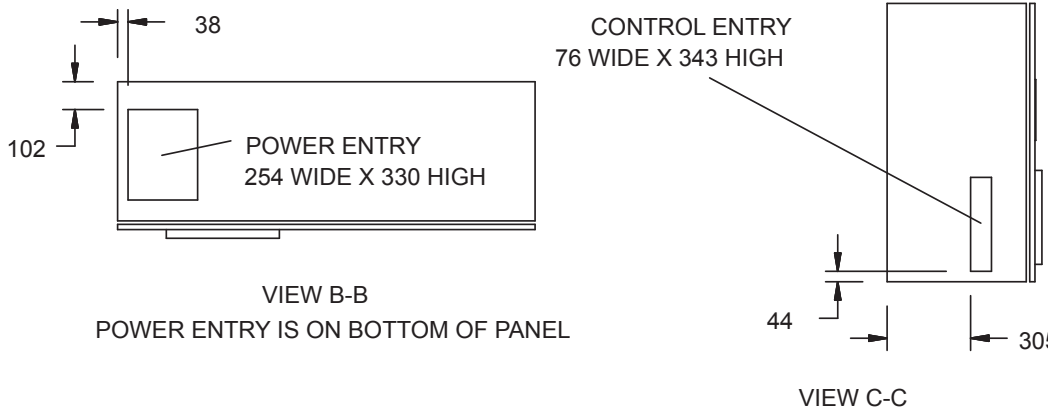

### Notes:

1. Placement on a level surface free of obstructions (including snow, for winter operation) or air recirculation ensure rated performance, reliable operation, and ease of maintenance. Site restrictions may compromise minimum clearances indicated below, resulting in unpredictable air patterns and possible diminished performance. Johnson Controls' unit controls will optimize the operation without nuisance high pressure safety cutouts; however, the system designer **MUST** consider potential performance degradation.
2. Access to the unit control center stipulates the unit is no higher when on spring isolators. Recommended minimum clearances: side to wall - 2m; rear to wall - 2m control panel end to wall - 1.2m; top - no obstructions whatsoever; distance between adjacent units - 3m. No more than one adjacent wall may be higher than the unit.

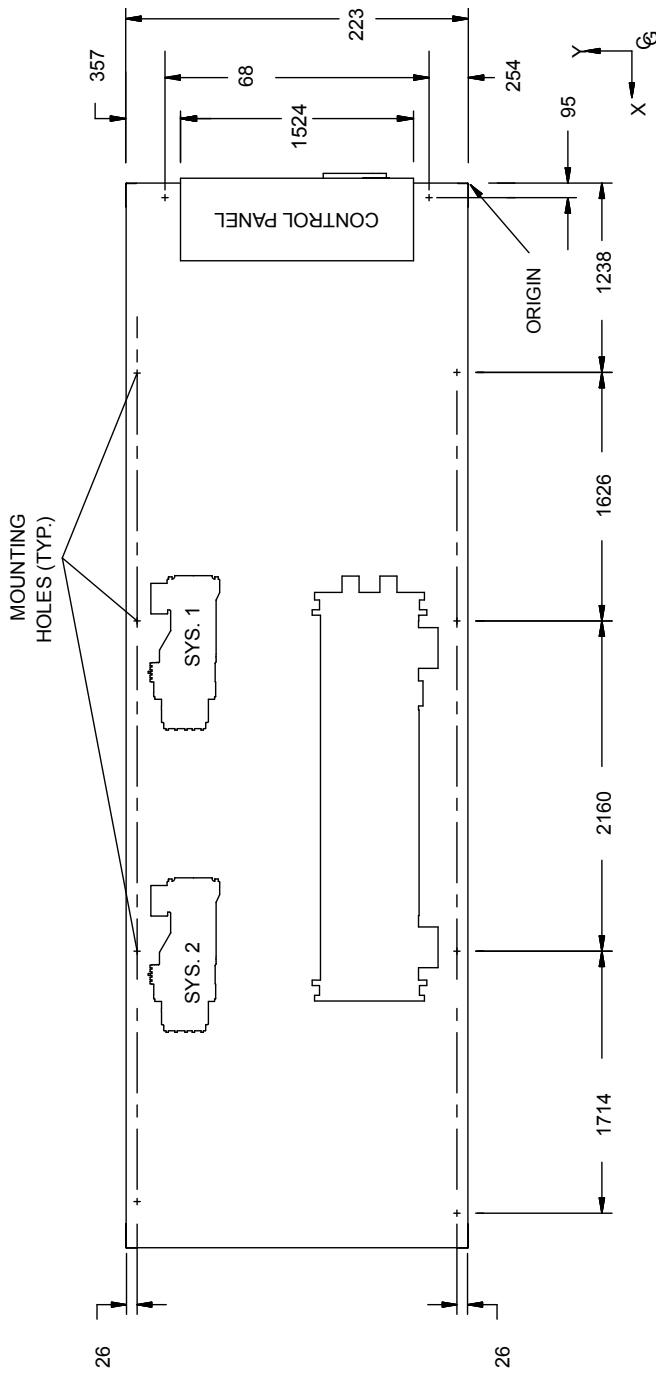

VIEW D-D

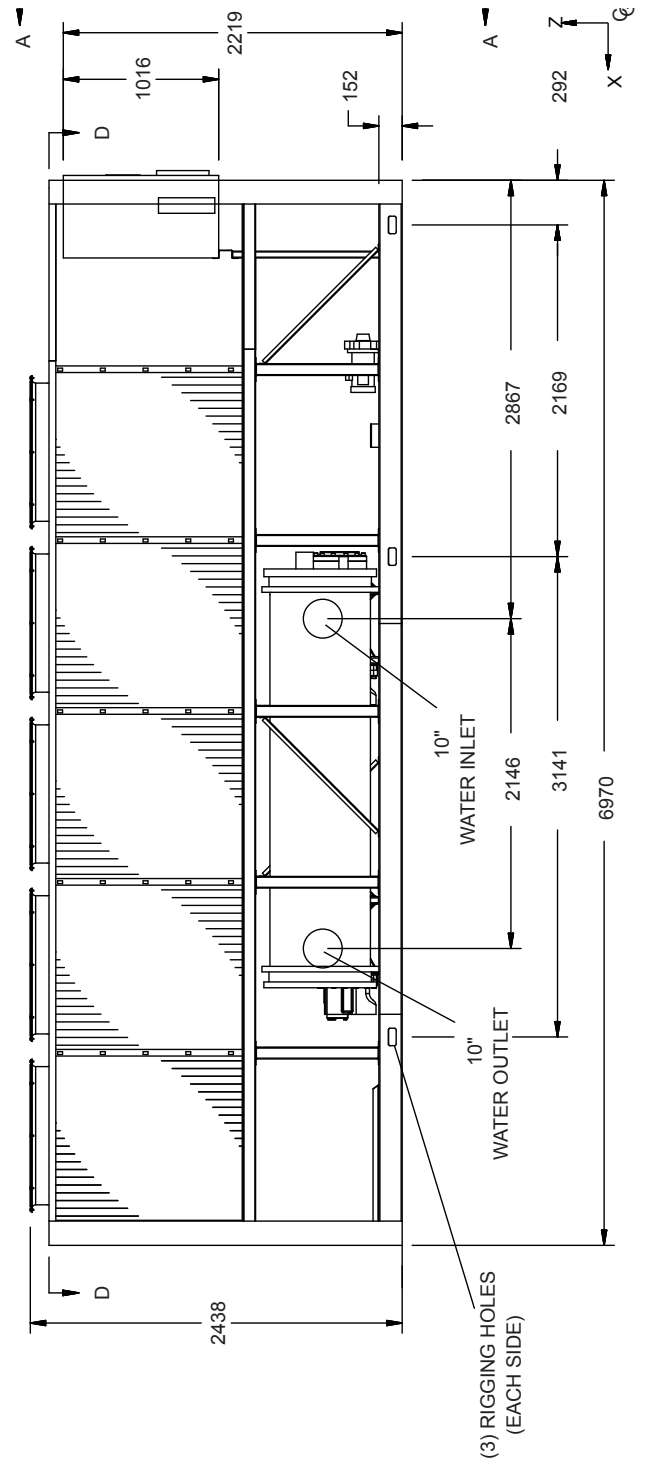

# Dimensions - SI - continued

## YCAV0197E/V

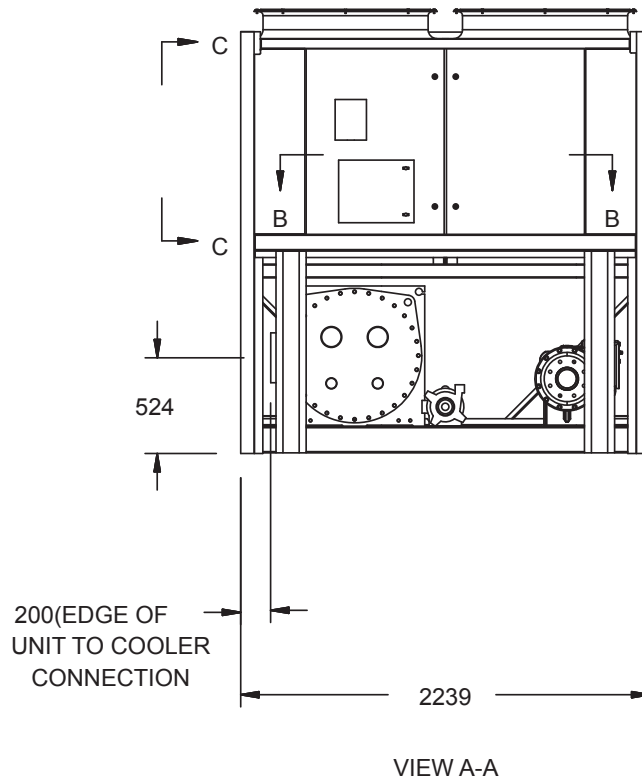
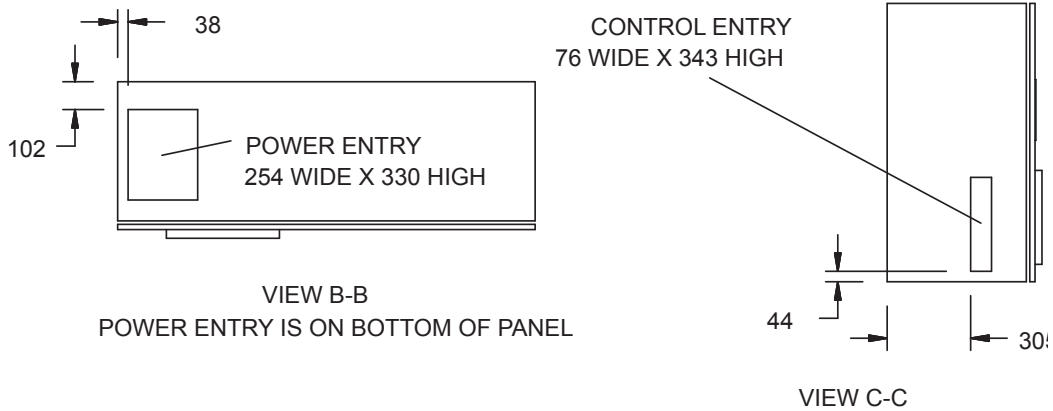

### Notes:

1. Placement on a level surface free of obstructions (including snow, for winter operation) or air recirculation ensure rated performance, reliable operation, and ease of maintenance. Site restrictions may compromise minimum clearances indicated below, resulting in unpredictable air patterns and possible diminished performance. Johnson Controls' unit controls will optimize the operation without nuisance high pressure safety cutouts; however, the system designer **MUST** consider potential performance degradation.
2. Access to the unit control center stipulates the unit is no higher when on spring isolators. Recommended minimum clearances: side to wall - 2m; rear to wall - 2m control panel end to wall - 1.2m; top - no obstructions whatsoever; distance between adjacent units - 3m. No more than one adjacent wall may be higher than the unit.



# Dimensions - SI - continued

## YCAV0207S/P, 0227S/P

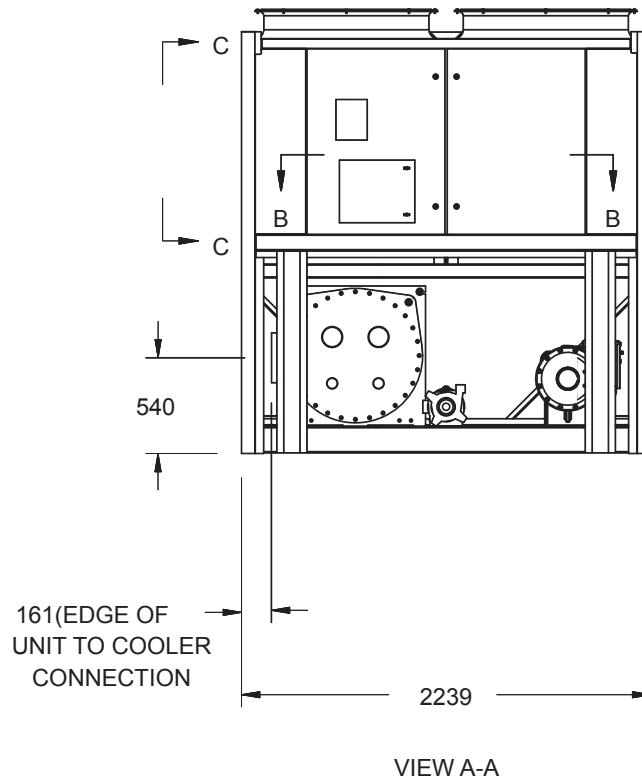
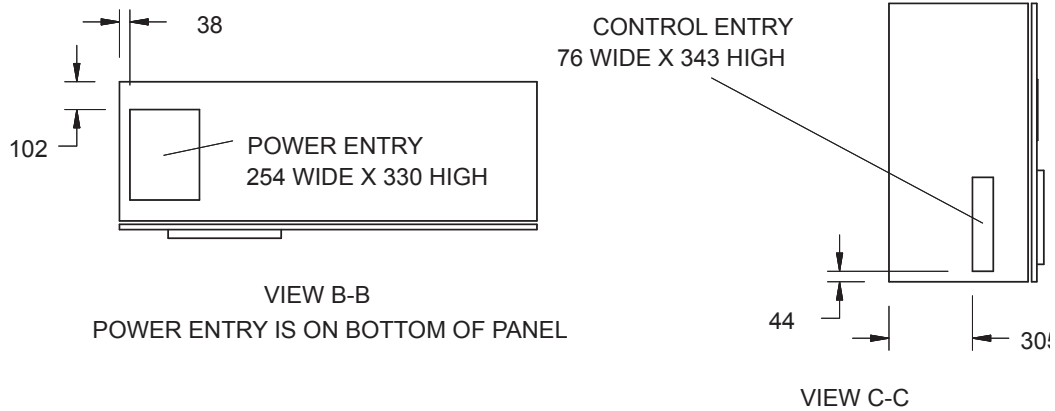

### Notes:

1. Placement on a level surface free of obstructions (including snow, for winter operation) or air recirculation ensure rated performance, reliable operation, and ease of maintenance. Site restrictions may compromise minimum clearances indicated below, resulting in unpredictable air patterns and possible diminished performance. Johnson Controls' unit controls will optimize the operation without nuisance high pressure safety cutouts; however, the system designer **MUST** consider potential performance degradation.
2. Access to the unit control center stipulates the unit is no higher when on spring isolators. Recommended minimum clearances: side to wall - 2m; rear to wall - 2m control panel end to wall - 1.2m; top - no obstructions whatsoever; distance between adjacent units - 3m. No more than one adjacent wall may be higher than the unit.





# Dimensions - SI - continued

## YCAV0207E/V, 0227E/V

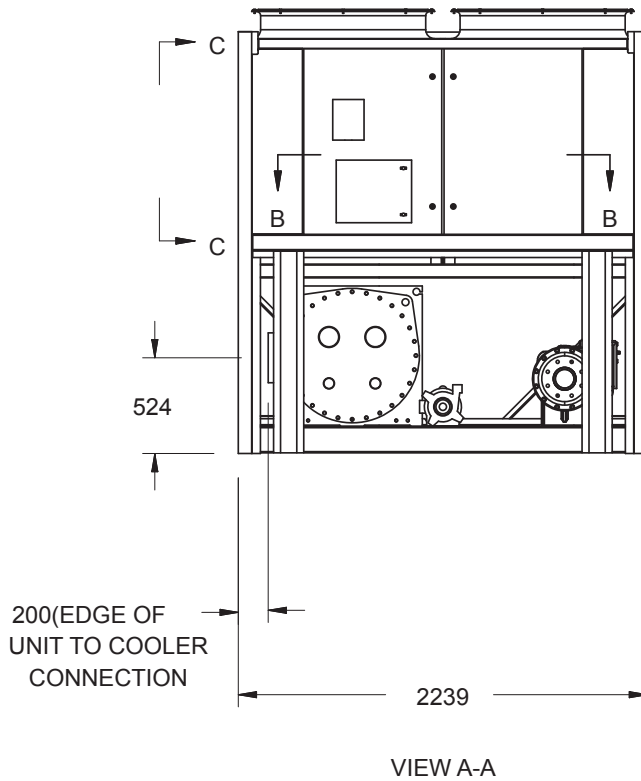
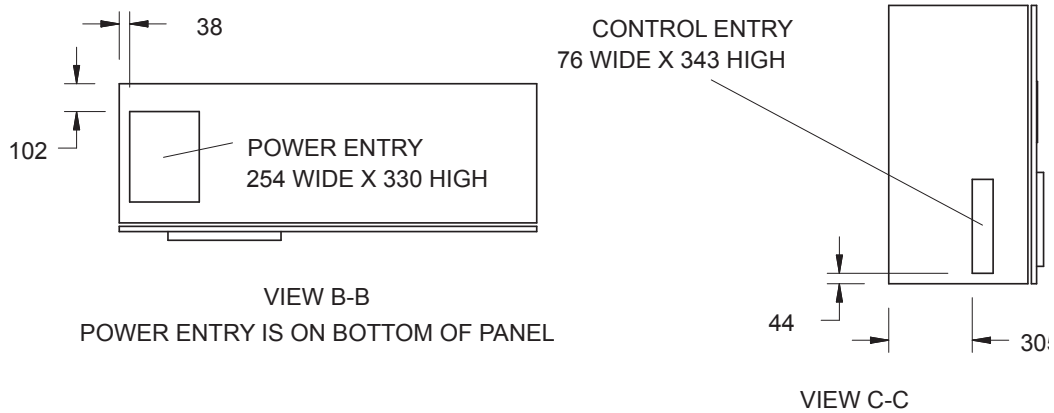

### Notes:

1. Placement on a level surface free of obstructions (including snow, for winter operation) or air recirculation ensure rated performance, reliable operation, and ease of maintenance. Site restrictions may compromise minimum clearances indicated below, resulting in unpredictable air patterns and possible diminished performance. Johnson Controls' unit controls will optimize the operation without nuisance high pressure safety cutouts; however, the system designer **MUST** consider potential performance degradation.
2. Access to the unit control center stipulates the unit is no higher when on spring isolators. Recommended minimum clearances: side to wall - 2m; rear to wall - 2m control panel end to wall - 1.2m; top - no obstructions whatsoever; distance between adjacent units - 3m. No more than one adjacent wall may be higher than the unit.

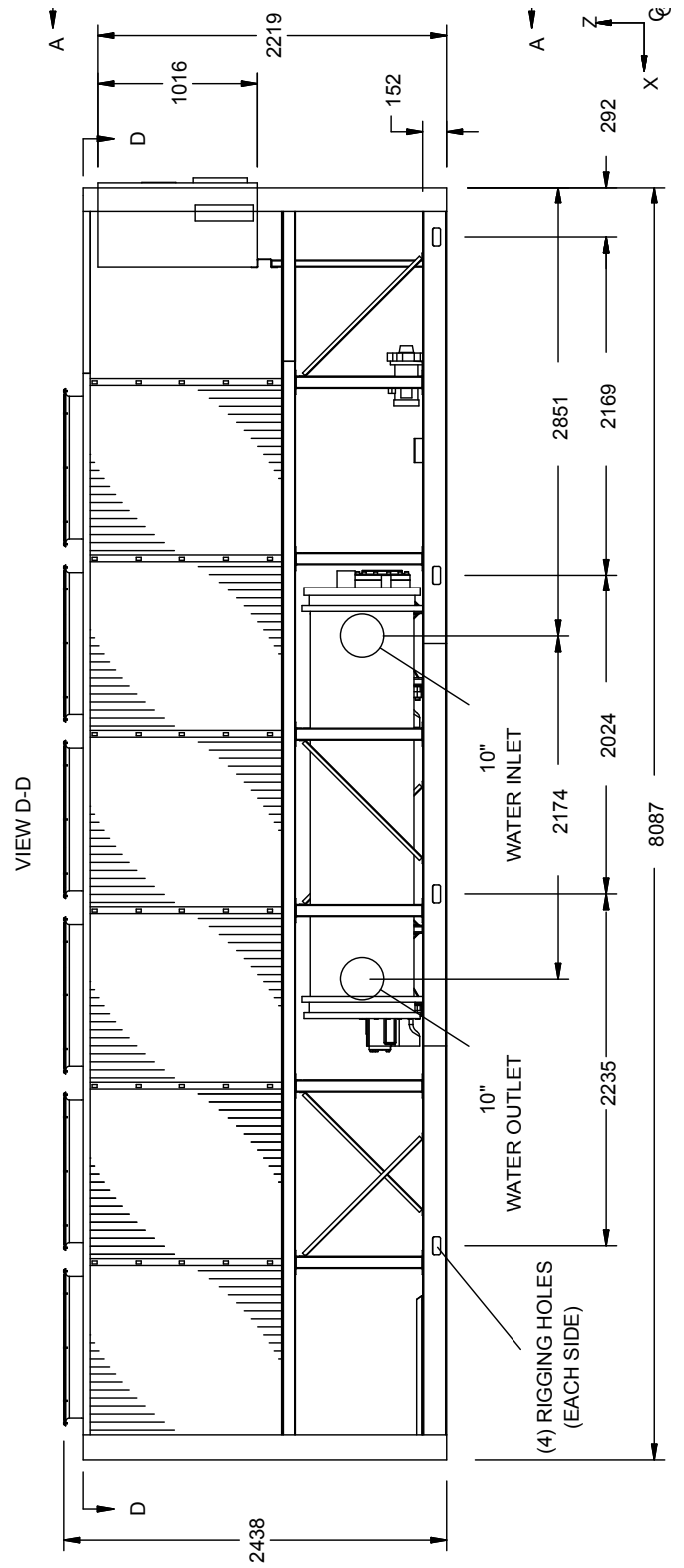
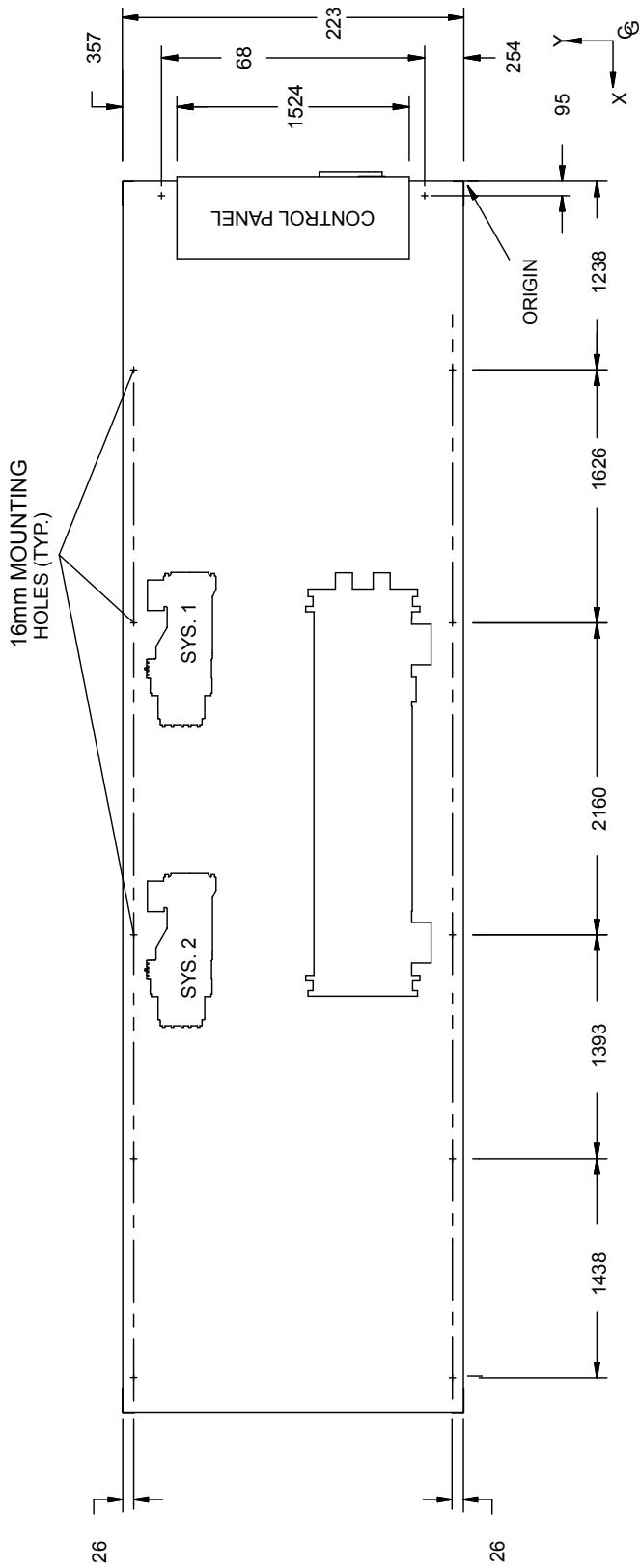

# Dimensions - SI - continued

## YCAV0247S/P, 0247E/V, 0267S/P

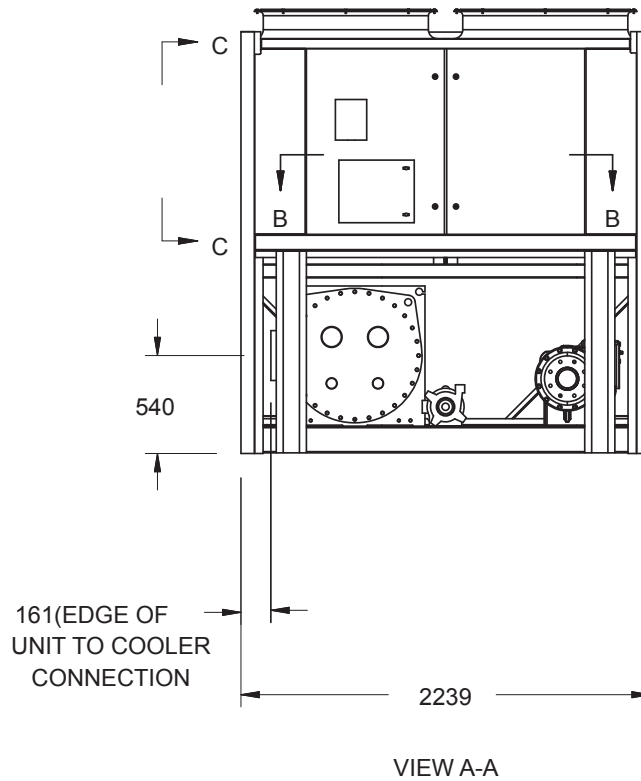
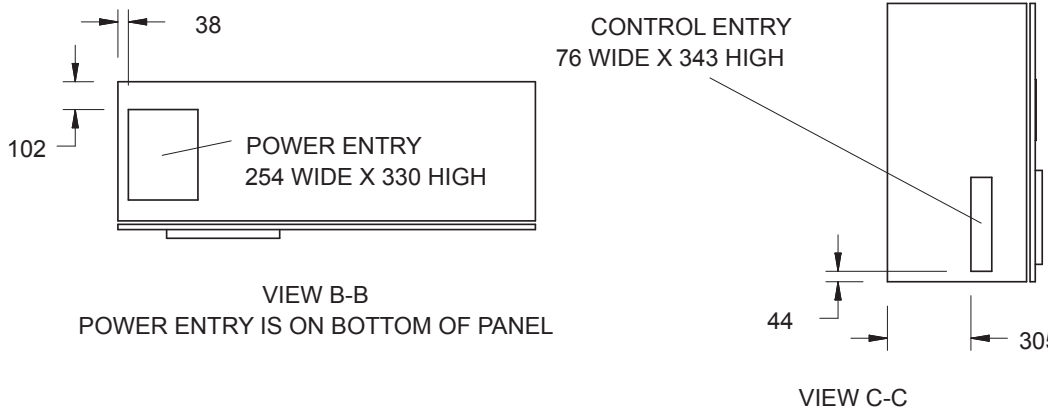

### Notes:

1. Placement on a level surface free of obstructions (including snow, for winter operation) or air recirculation ensure rated performance, reliable operation, and ease of maintenance. Site restrictions may compromise minimum clearances indicated below, resulting in unpredictable air patterns and possible diminished performance. Johnson Controls' unit controls will optimize the operation without nuisance high pressure safety cutouts; however, the system designer **MUST** consider potential performance degradation.
2. Access to the unit control center stipulates the unit is no higher when on spring isolators. Recommended minimum clearances: side to wall - 2m; rear to wall - 2m control panel end to wall - 1.2m; top - no obstructions whatsoever; distance between adjacent units - 3m. No more than one adjacent wall may be higher than the unit.

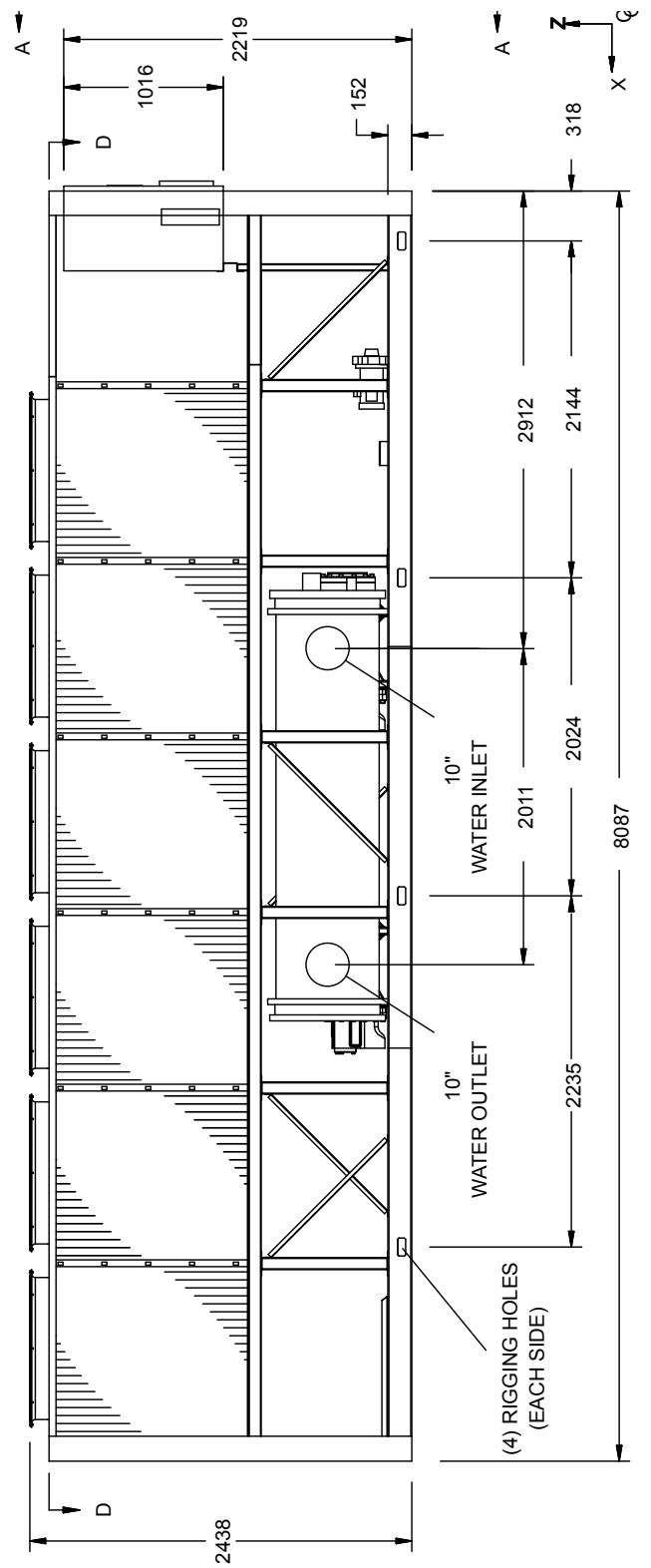
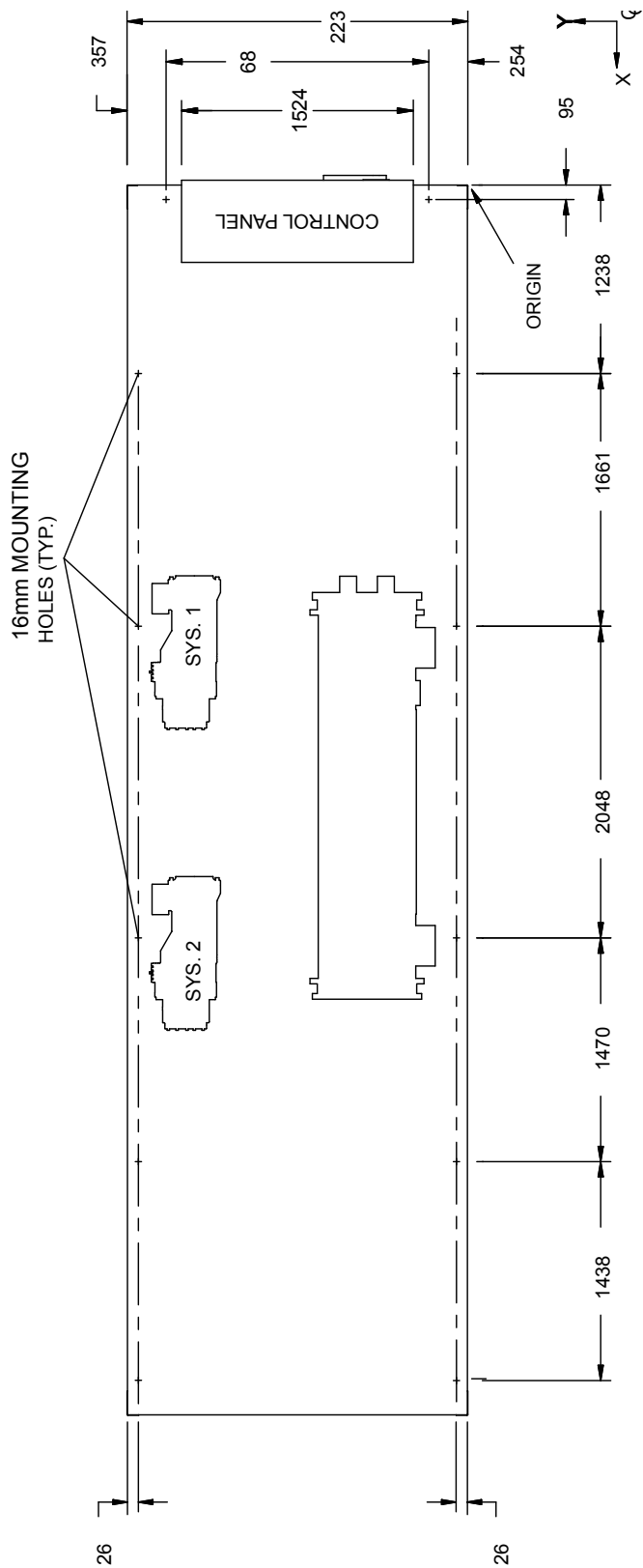

# Dimensions - SI - continued

## YCAV0267E/V, 0287S/P

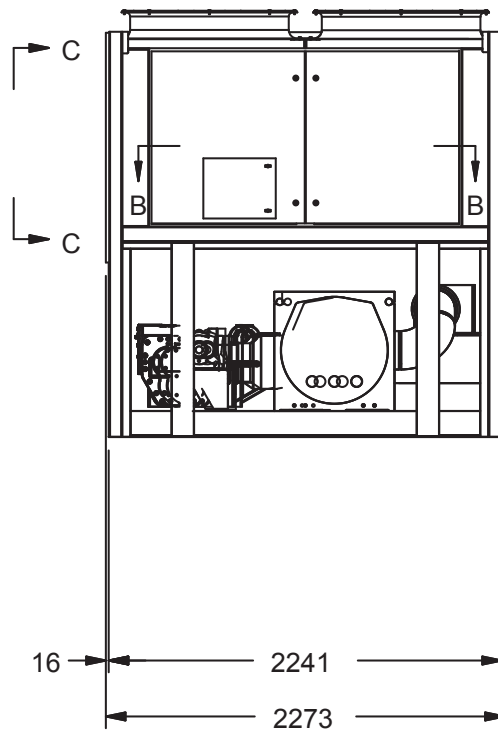
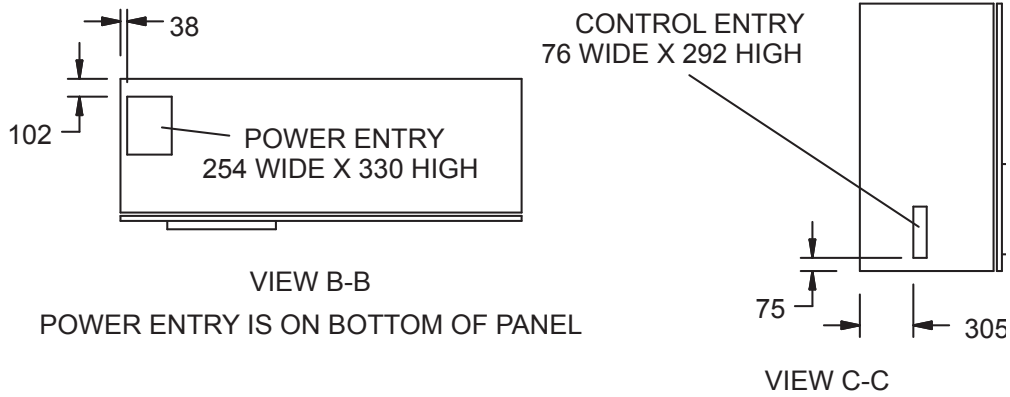

### Notes:

1. Placement on a level surface free of obstructions (including snow, for winter operation) or air recirculation ensure rated performance, reliable operation, and ease of maintenance. Site restrictions may compromise minimum clearances indicated below, resulting in unpredictable air patterns and possible diminished performance. Johnson Controls' unit controls will optimize the operation without nuisance high pressure safety cutouts; however, the system designer **MUST** consider potential performance degradation.
2. Access to the unit control center stipulates the unit is no higher when on spring isolators. Recommended minimum clearances: side to wall - 2m; rear to wall - 2m control panel end to wall - 1.2m; top - no obstructions whatsoever; distance between adjacent units - 3m. No more than one adjacent wall may be higher than the unit.

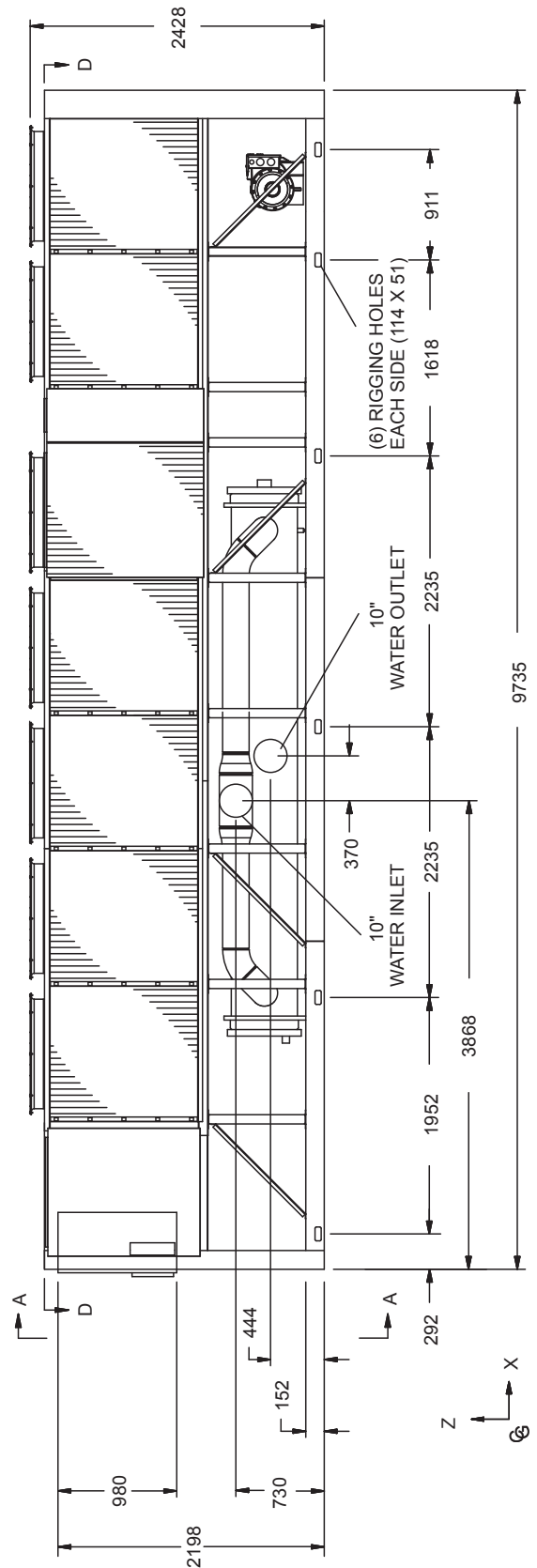
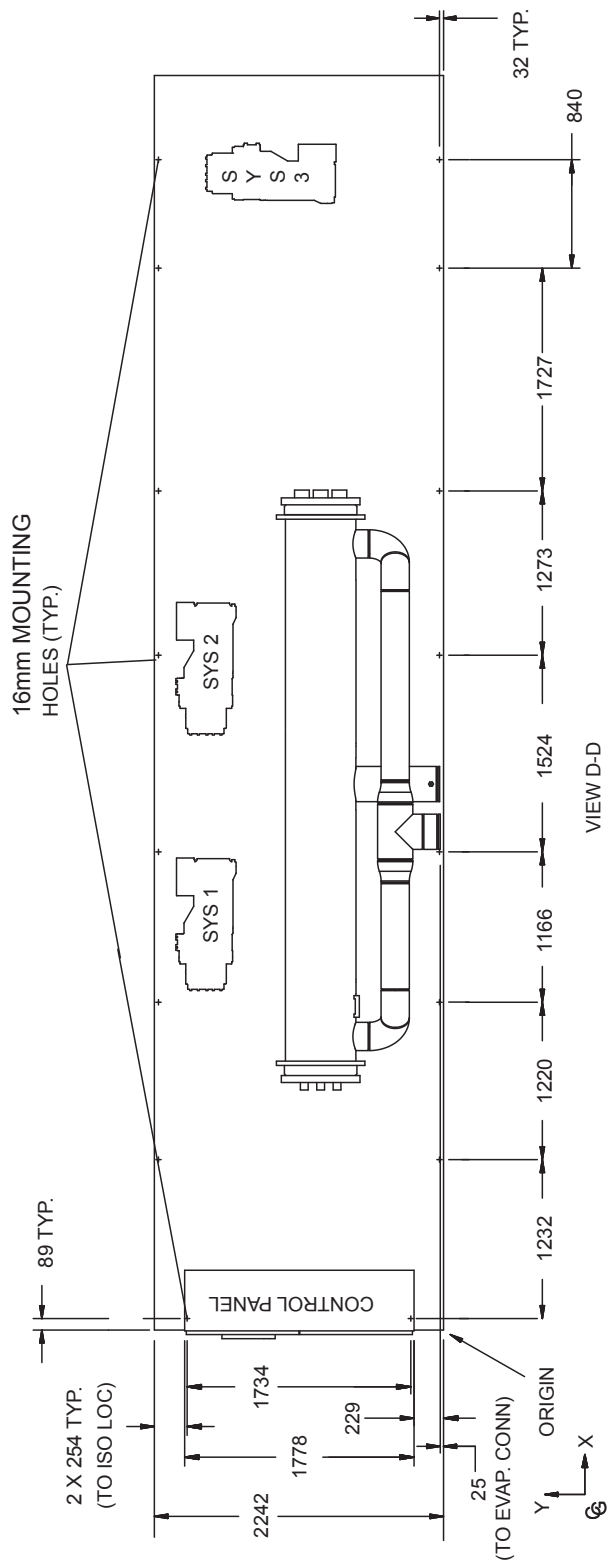

# Dimensions - SI - continued

## YCAV0287E/V

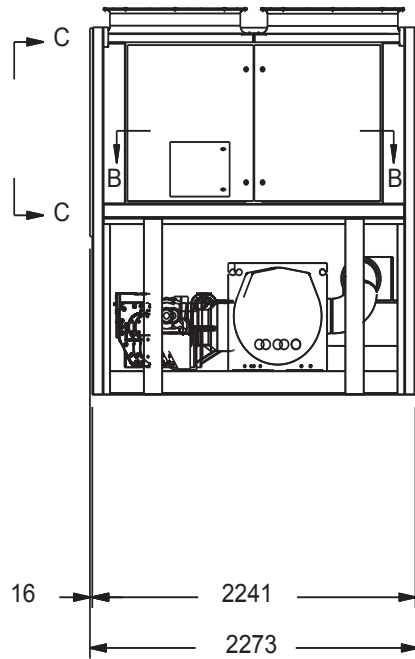
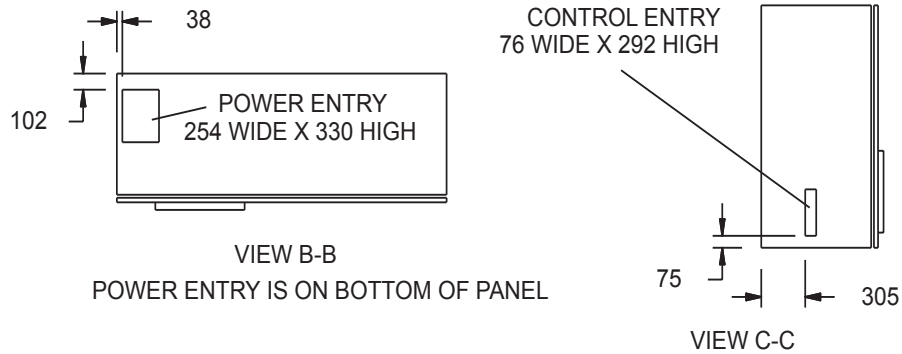

### Notes:

1. Placement on a level surface free of obstructions (including snow, for winter operation) or air recirculation ensure rated performance, reliable operation, and ease of maintenance. Site restrictions may compromise minimum clearances indicated below, resulting in unpredictable air patterns and possible diminished performance. Johnson Controls' unit controls will optimize the operation without nuisance high pressure safety cutouts; however, the system designer MUST consider potential performance degradation.
2. Access to the unit control center stipulates the unit is no higher when on spring isolators. Recommended minimum clearances: side to wall - 2m; rear to wall - 2m control panel end to wall - 1.2m; top - no obstructions whatsoever; distance between adjacent units - 3m. No more than one adjacent wall may be higher than the unit.



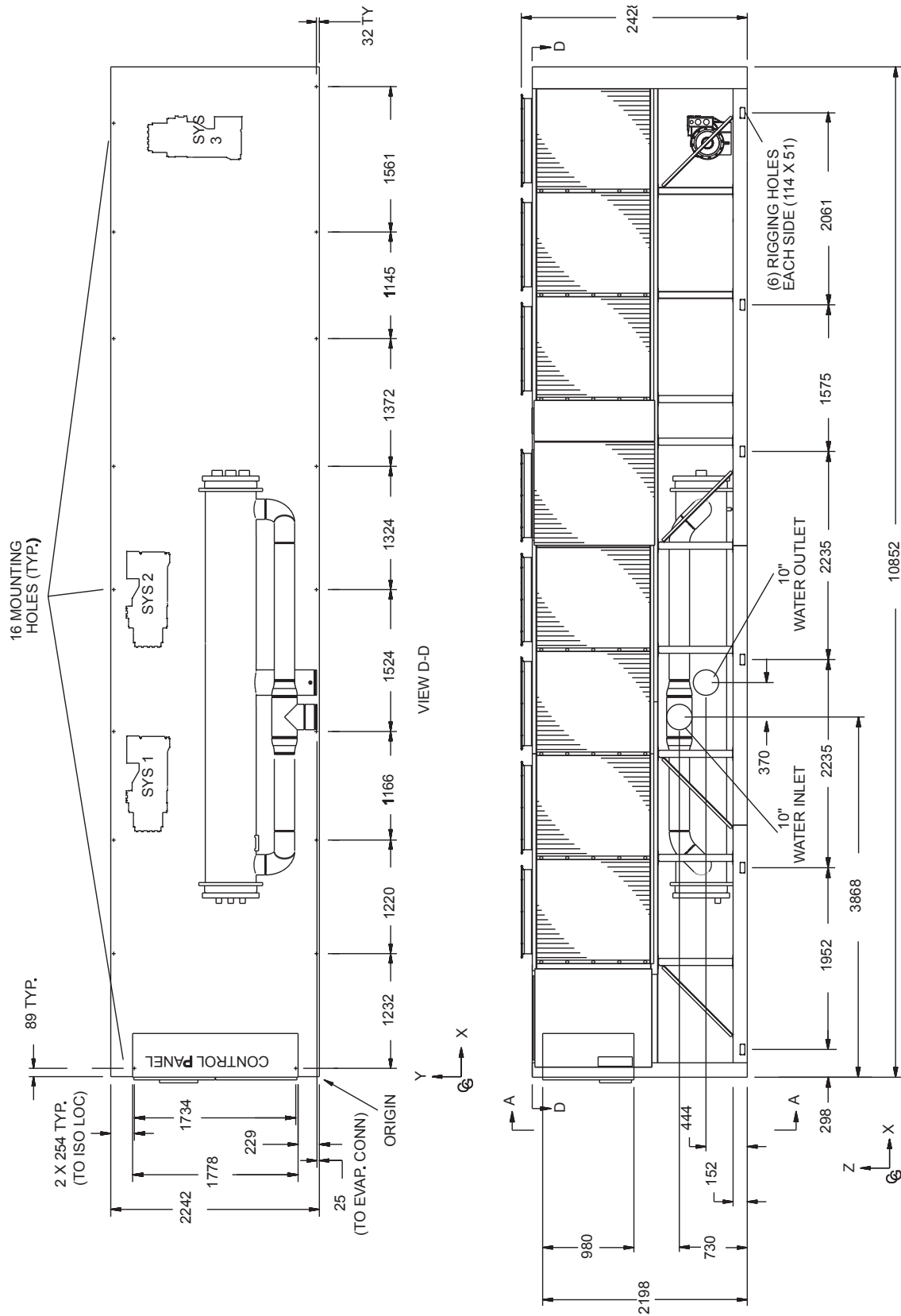

# Dimensions - SI - continued

## YCAV0307S/P

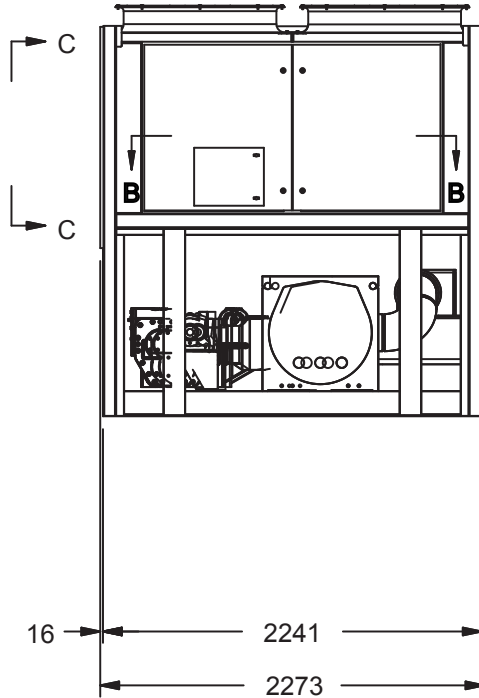
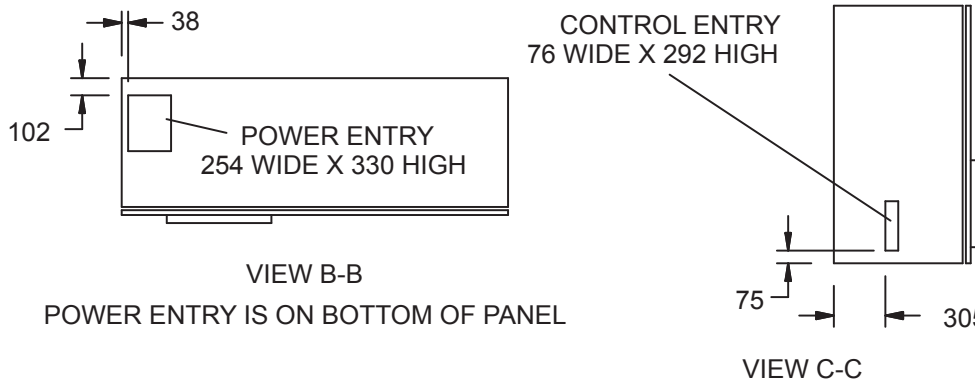

VIEW A-A

### Notes:

1. Placement on a level surface free of obstructions (including snow, for winter operation) or air recirculation ensure rated performance, reliable operation, and ease of maintenance. Site restrictions may compromise minimum clearances indicated below, resulting in unpredictable air patterns and possible diminished performance. Johnson Controls' unit controls will optimize the operation without nuisance high pressure safety cutouts; however, the system designer **MUST** consider potential performance degradation.
2. Access to the unit control center stipulates the unit is no higher when on spring isolators. Recommended minimum clearances: side to wall - 2m; rear to wall - 2m control panel end to wall - 1.2m; top - no obstructions whatsoever; distance between adjacent units - 3m. No more than one adjacent wall may be higher than the unit.

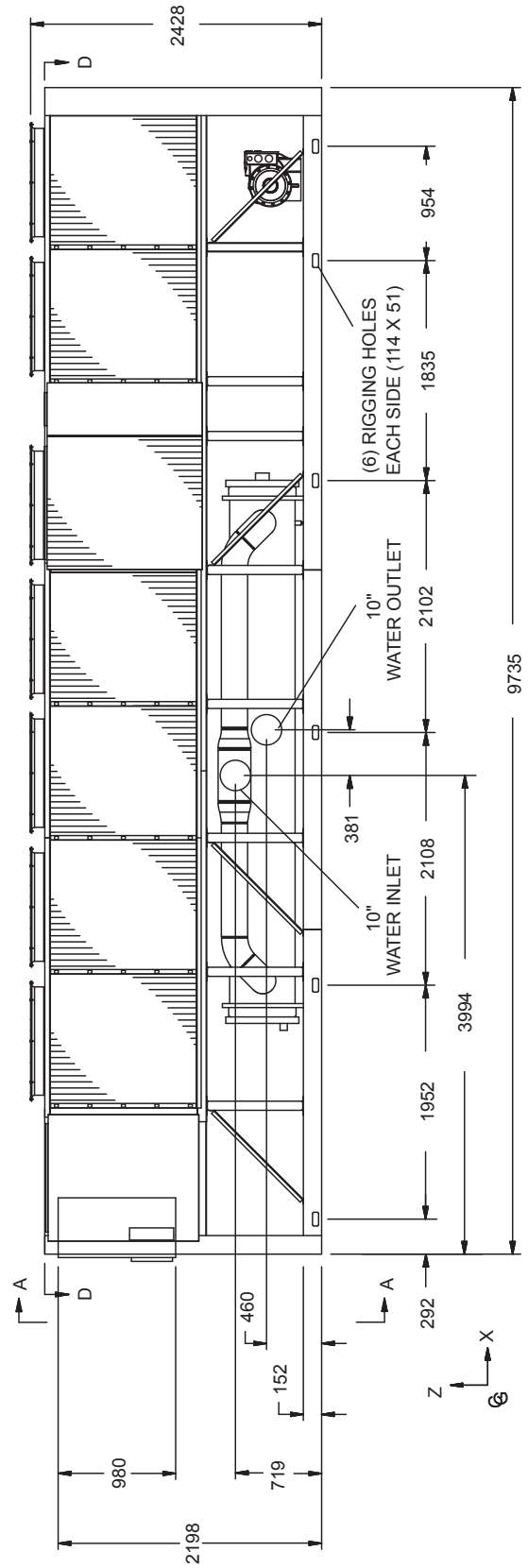
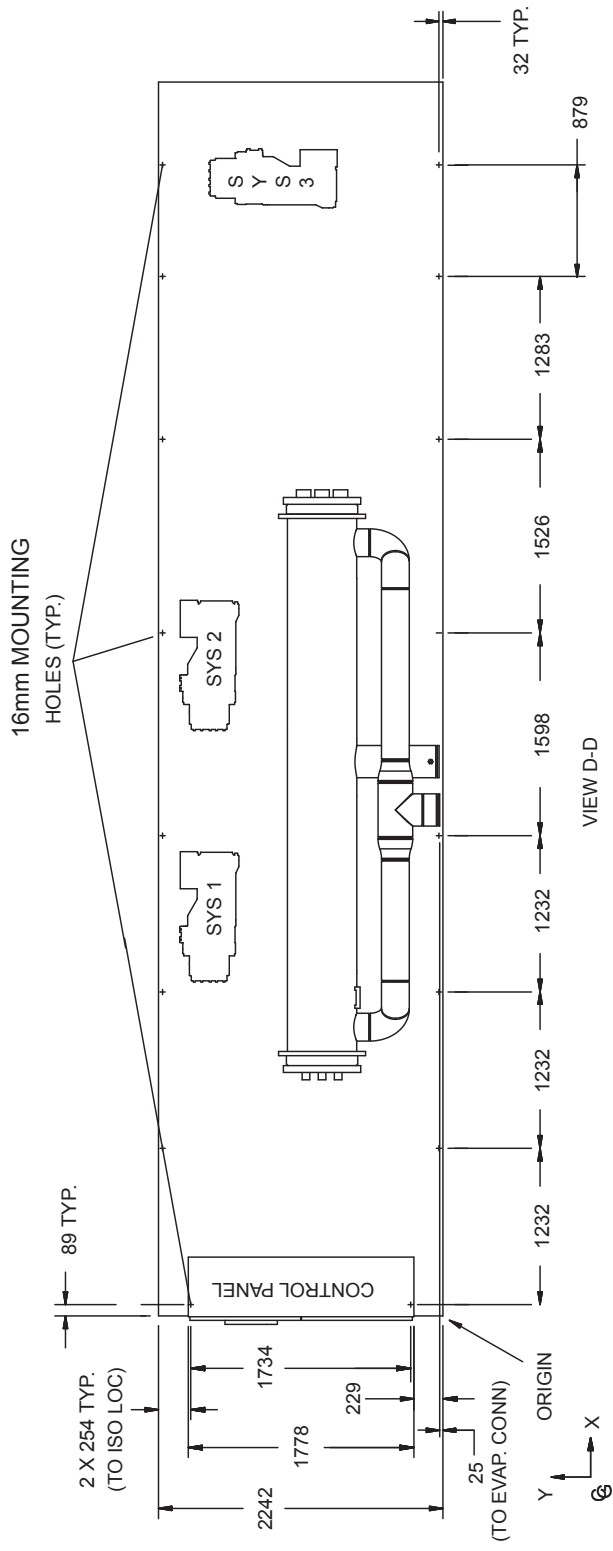

# Dimensions - SI - continued

## YCAV0327E/V, 0357S/P

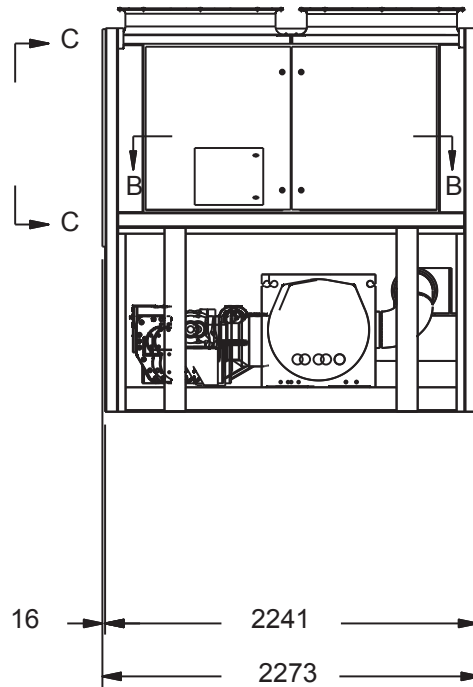
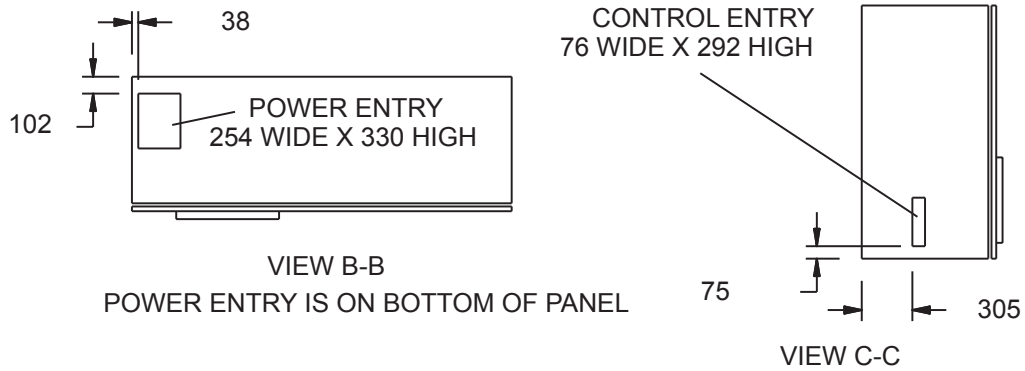

POWER: SINGLE POINT WITH TERMINAL BLOCK

### Notes:

1. Placement on a level surface free of obstructions (including snow, for winter operation) or air recirculation ensure rated performance, reliable operation, and ease of maintenance. Site restrictions may compromise minimum clearances indicated below, resulting in unpredictable air patterns and possible diminished performance. Johnson Controls' unit controls will optimize the operation without nuisance high pressure safety cutouts; however, the system designer MUST consider potential performance degradation.
2. Access to the unit control center stipulates the unit is no higher when on spring isolators. Recommended minimum clearances: side to wall - 2m; rear to wall - 2m control panel end to wall - 1.2m; top - no obstructions whatsoever; distance between adjacent units - 3m. No more than one adjacent wall may be higher than the unit.

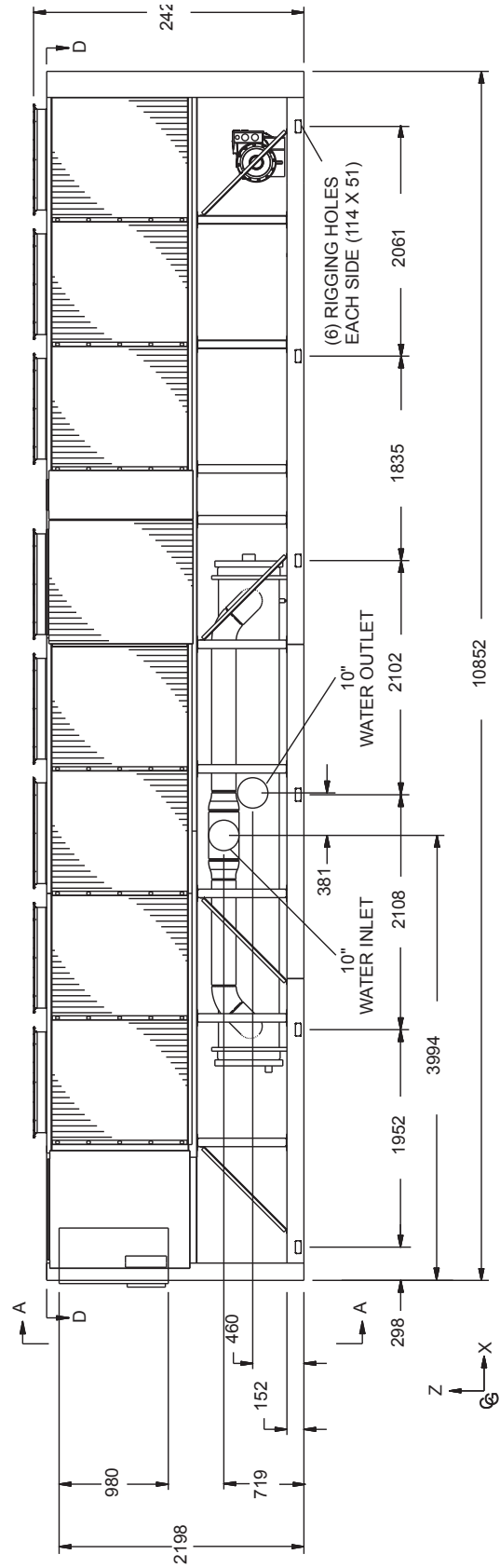
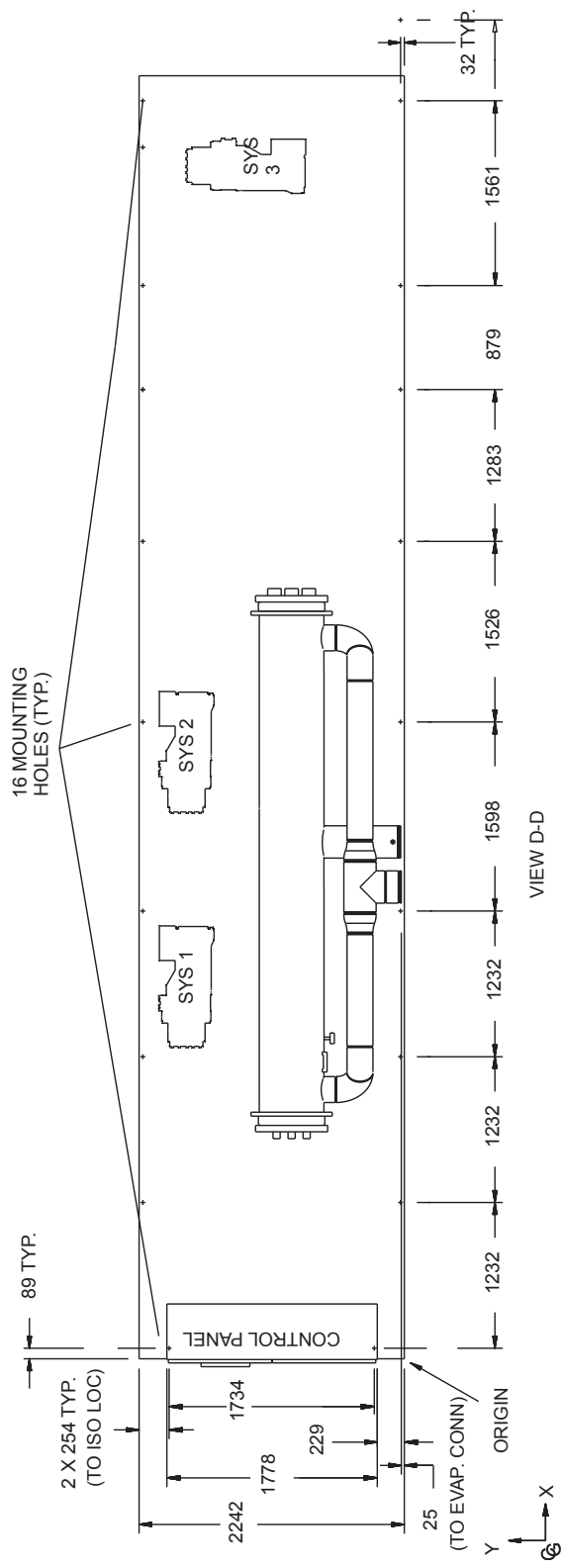

# Dimensions - SI - continued

## YCAV0357E/V, 0397S/V

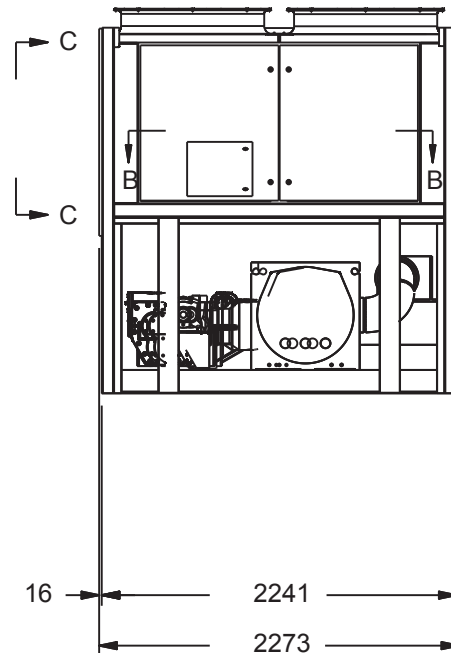
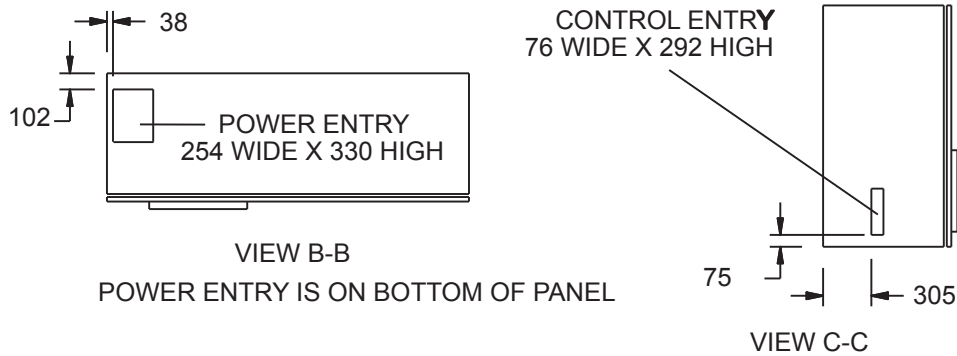

POWER: SINGLE POINT WITH TERMINAL BLOCK

**Notes:**

1. Placement on a level surface free of obstructions (including snow, for winter operation) or air recirculation ensure rated performance, reliable operation, and ease of maintenance. Site restrictions may compromise minimum clearances indicated below, resulting in unpredictable air patterns and possible diminished performance. Johnson Controls' unit controls will optimize the operation without nuisance high pressure safety cutouts; however, the system designer **MUST** consider potential performance degradation.
2. Access to the unit control center stipulates the unit is no higher when on spring isolators. Recommended minimum clearances: side to wall - 2m; rear to wall - 2m control panel end to wall - 1.2m; top - no obstructions whatsoever; distance between adjacent units - 3m. No more than one adjacent wall may be higher than the unit.

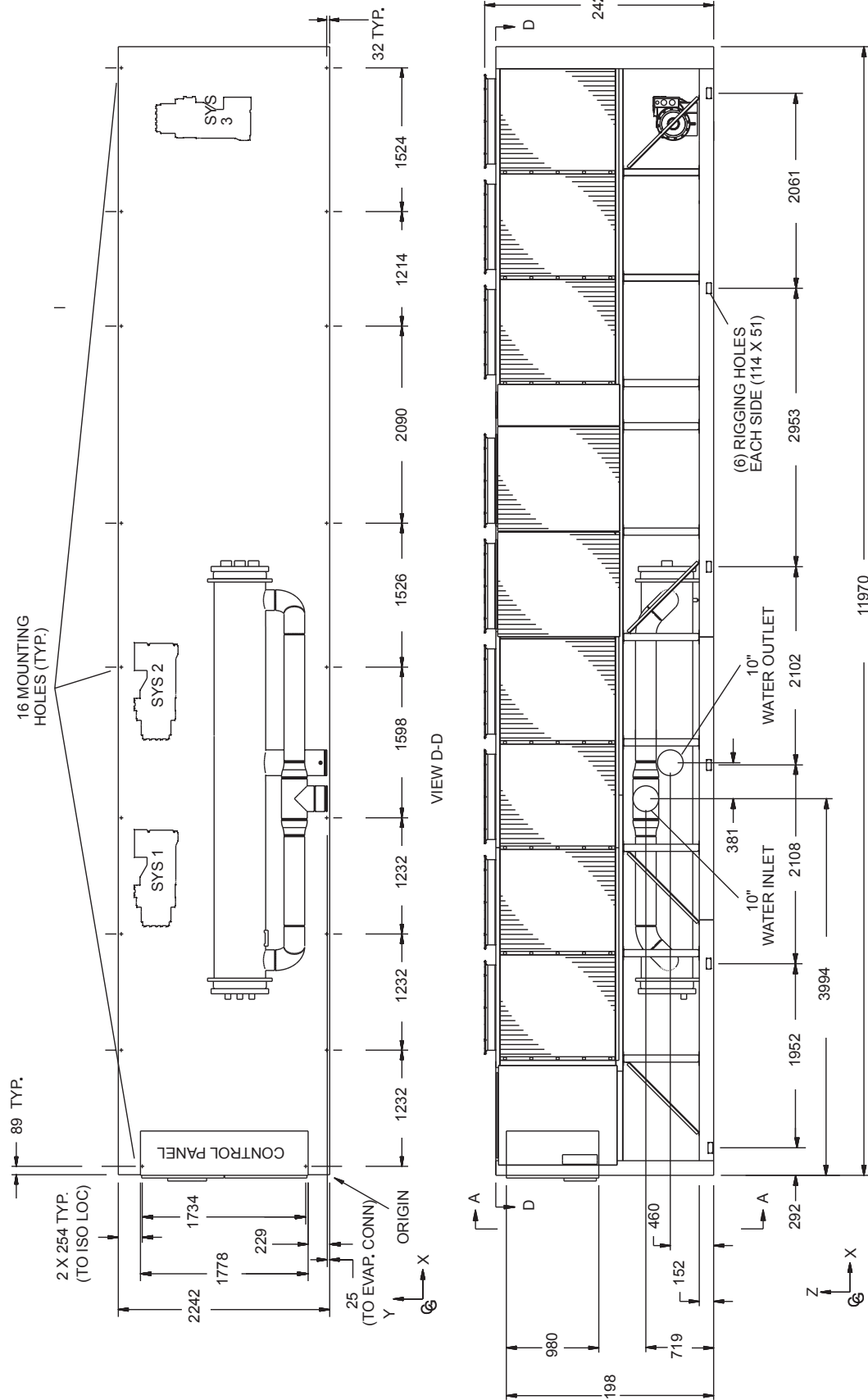

# Dimensions - SI - continued

YCAV0397E/V, 0417S/P, 1429E/V, 1549S/P

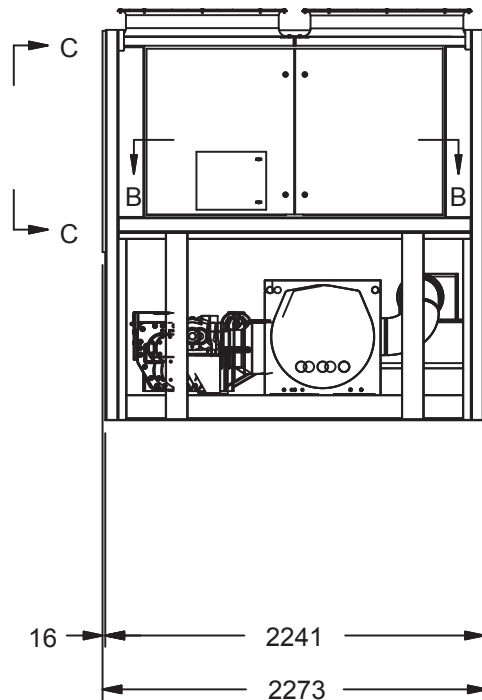
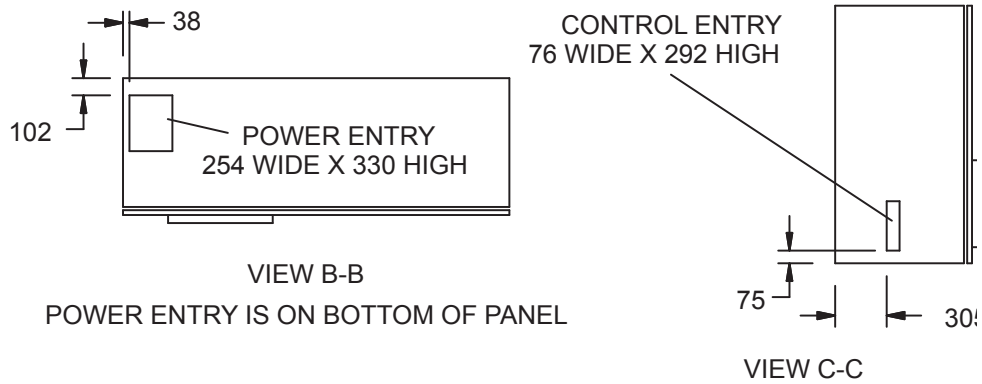

VIEW A-A

**Notes:**

1. Placement on a level surface free of obstructions (including snow, for winter operation) or air recirculation ensure rated performance, reliable operation, and ease of maintenance. Site restrictions may compromise minimum clearances indicated below, resulting in unpredictable air patterns and possible diminished performance. Johnson Controls' unit controls will optimize the operation without nuisance high pressure safety cutouts; however, the system designer **MUST** consider potential performance degradation.
2. Access to the unit control center stipulates the unit is no higher when on spring isolators. Recommended minimum clearances: side to wall - 2m; rear to wall - 2m control panel end to wall - 1.2m; top - no obstructions whatsoever; distance between adjacent units - 3m. No more than one adjacent wall may be higher than the unit.



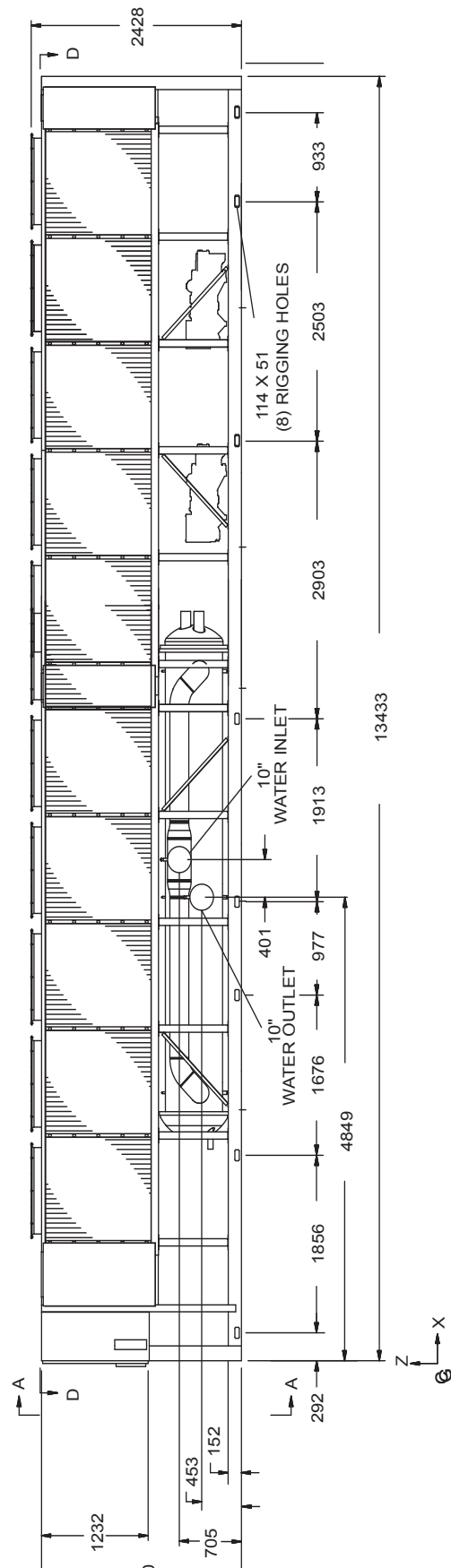
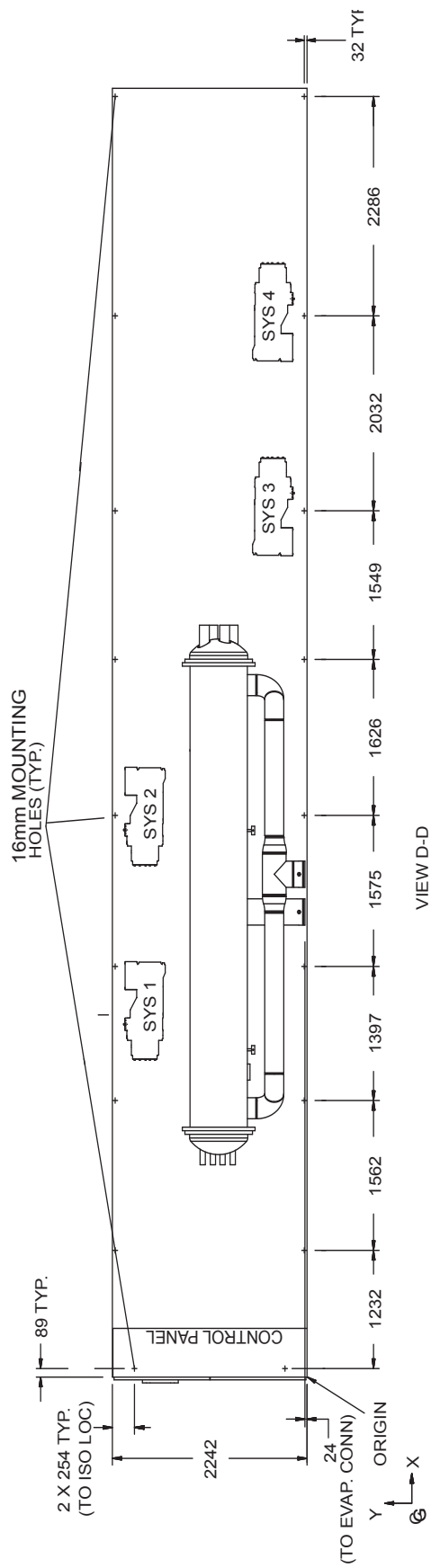

# Dimensions - SI - continued

## YCAV0417E/V, 0477S/P, 1549E/V, 1739S/P

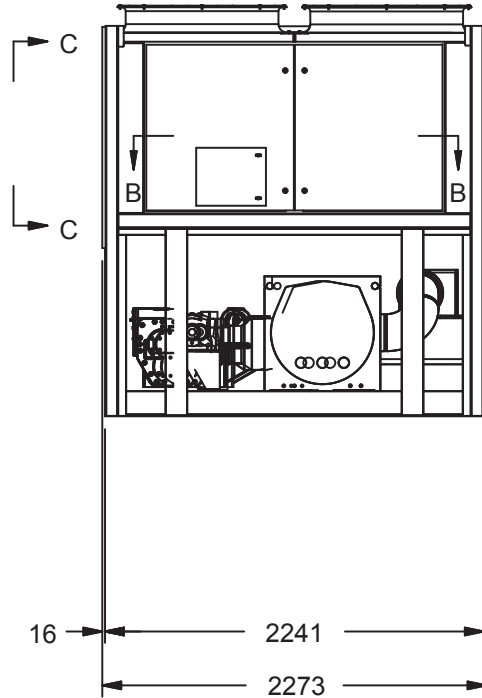
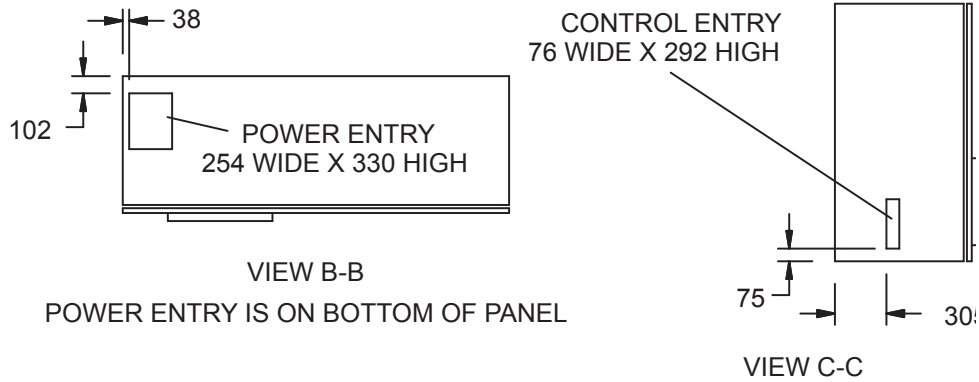

**Notes:**

1. Placement on a level surface free of obstructions (including snow, for winter operation) or air recirculation ensure rated performance, reliable operation, and ease of maintenance. Site restrictions may compromise minimum clearances indicated below, resulting in unpredictable air patterns and possible diminished performance. Johnson Controls' unit controls will optimize the operation without nuisance high pressure safety cutouts; however, the system designer **MUST** consider potential performance degradation.
2. Access to the unit control center stipulates the unit is no higher when on spring isolators. Recommended minimum clearances: side to wall - 2m; rear to wall - 2m control panel end to wall - 1.2m; top - no obstructions whatsoever; distance between adjacent units - 3m. No more than one adjacent wall may be higher than the unit.

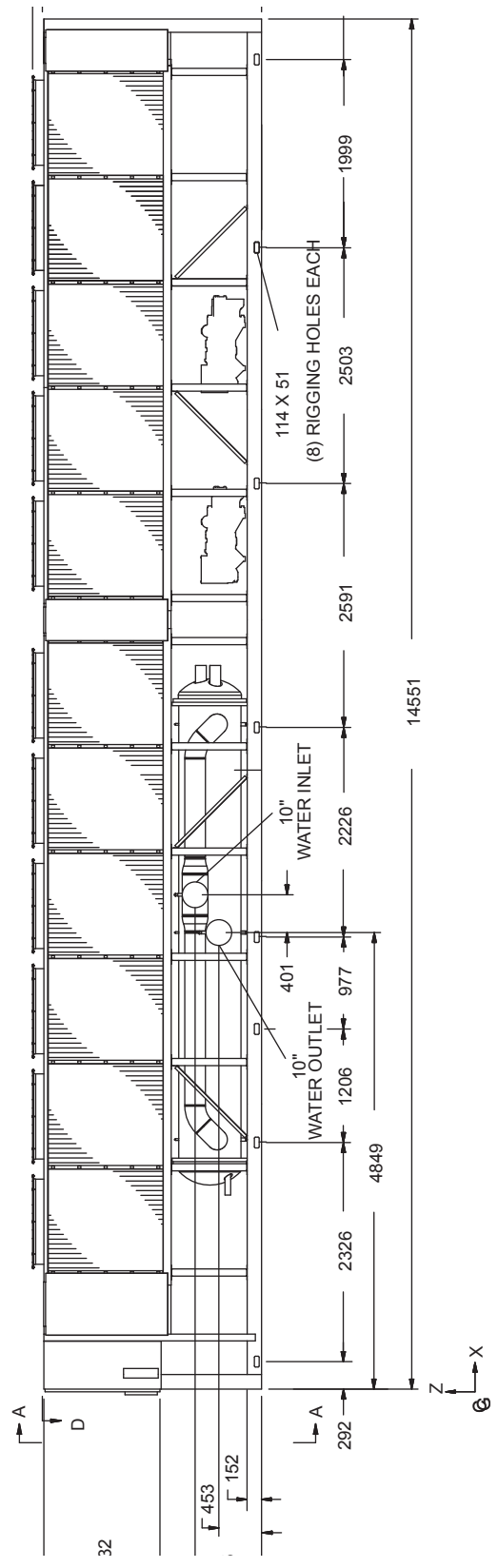
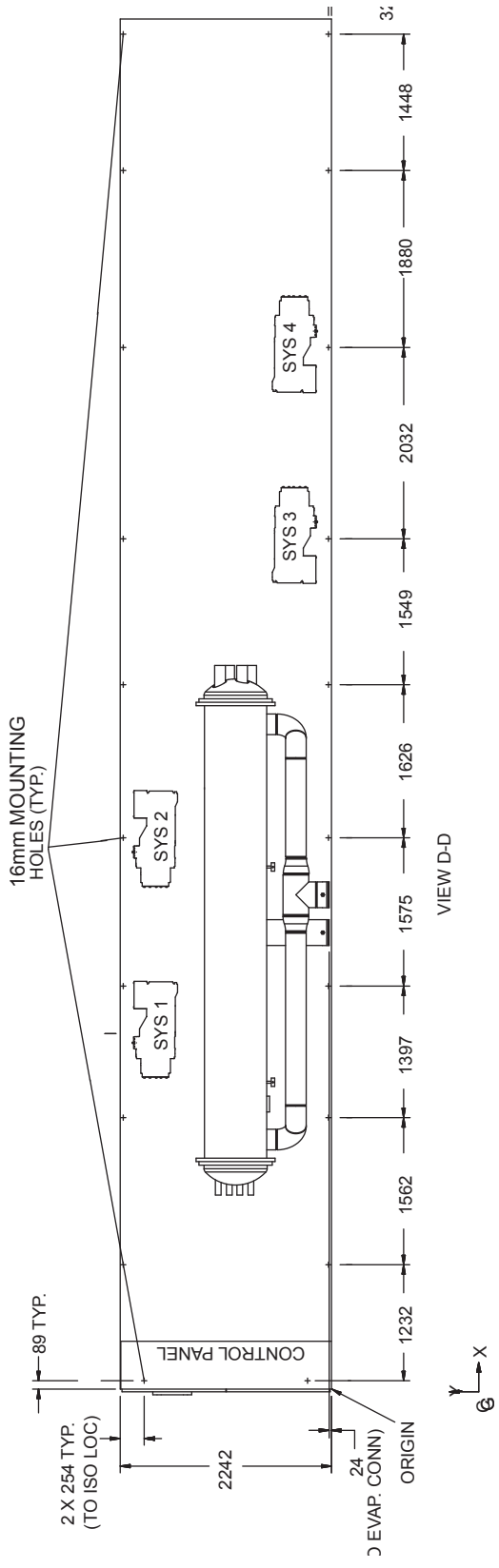

# Dimensions - SI - continued

## YCAV0457S/P, 1649S/P

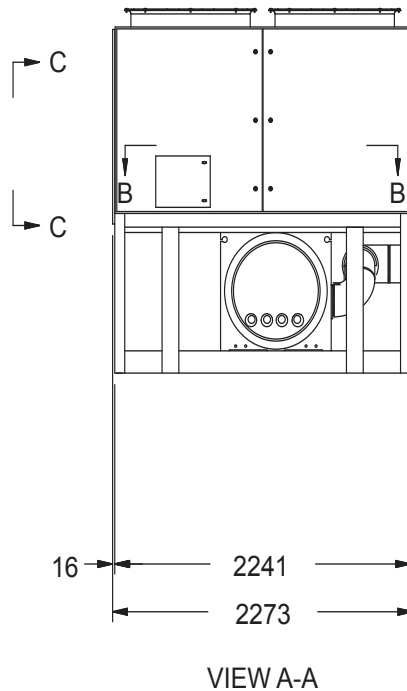
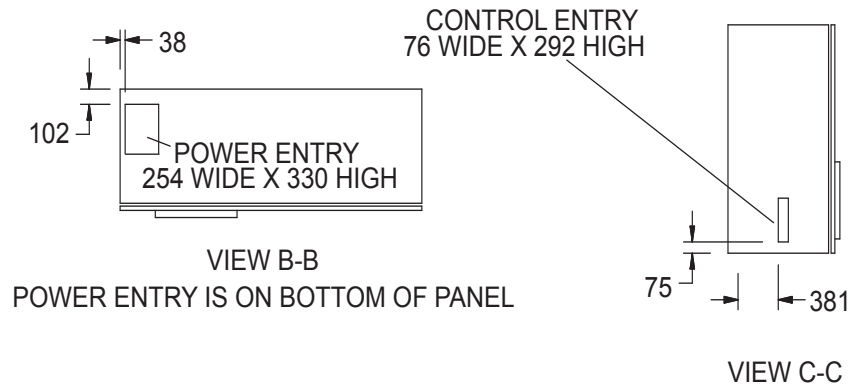

### Notes:

1. Placement on a level surface free of obstructions (including snow, for winter operation) or air recirculation ensure rated performance, reliable operation, and ease of maintenance. Site restrictions may compromise minimum clearances indicated below, resulting in unpredictable air patterns and possible diminished performance. Johnson Controls' unit controls will optimize the operation without nuisance high pressure safety cutouts; however, the system designer MUST consider potential performance degradation.
2. Access to the unit control center stipulates the unit is no higher when on spring isolators. Recommended minimum clearances: side to wall - 2m; rear to wall - 2m control panel end to wall - 1.2m; top - no obstructions whatsoever; distance between adjacent units - 3m. No more than one adjacent wall may be higher than the unit.

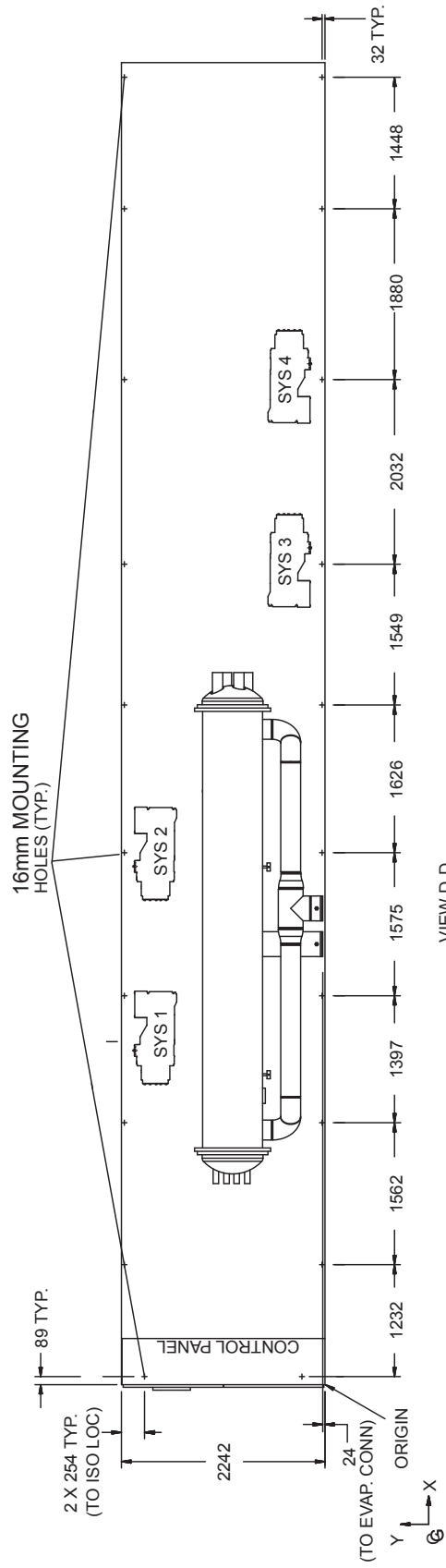

VIEW D-D

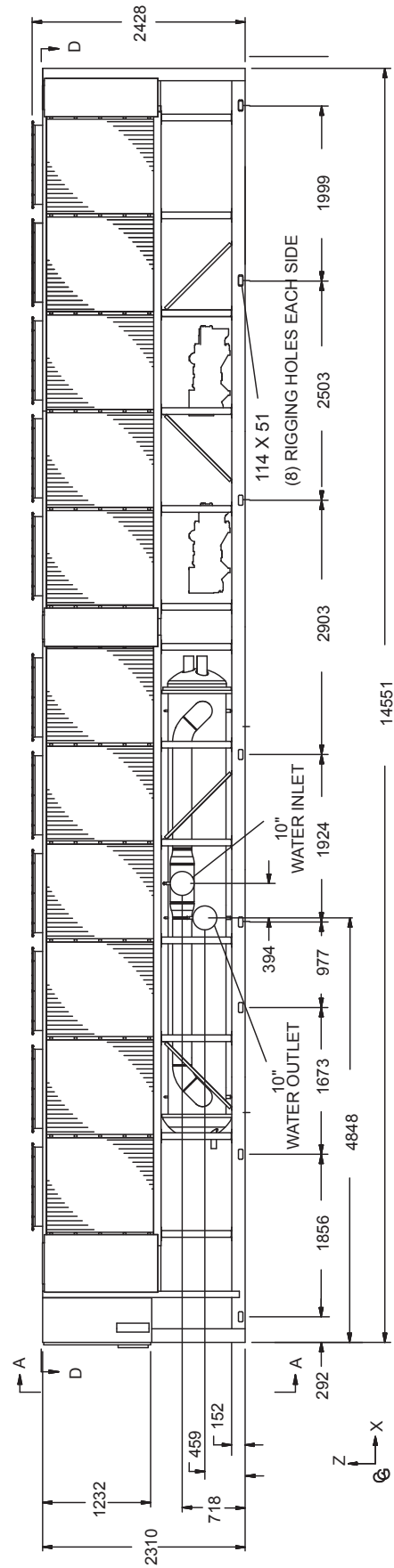

# Dimensions - SI - continued

**YCAV0477E/V, 0507S/P, 0527S/P, 1739E/V, 1829S/P, 1909S/P**

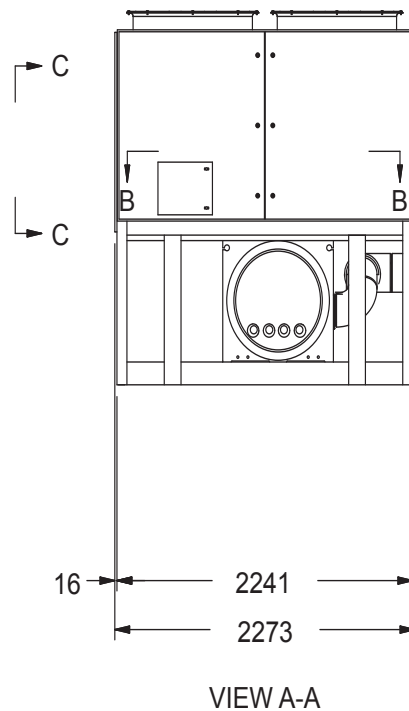
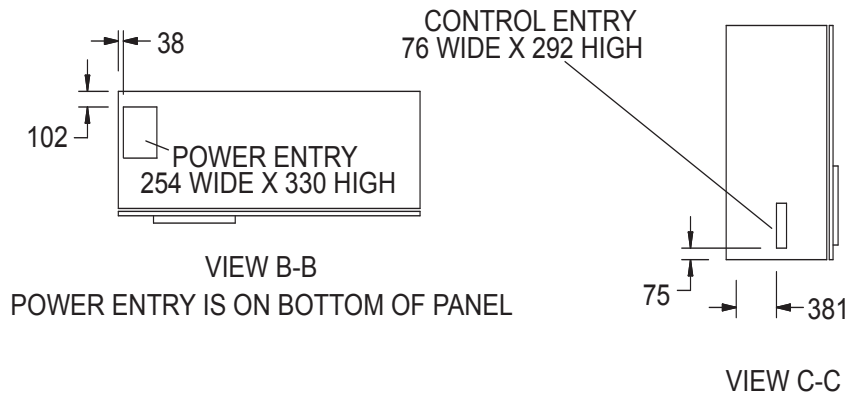

**Notes:**

1. Placement on a level surface free of obstructions (including snow, for winter operation) or air recirculation ensure rated performance, reliable operation, and ease of maintenance. Site restrictions may compromise minimum clearances indicated below, resulting in unpredictable air patterns and possible diminished performance. Johnson Controls' unit controls will optimize the operation without nuisance high pressure safety cutouts; however, the system designer **MUST** consider potential performance degradation.
2. Access to the unit control center stipulates the unit is no higher when on spring isolators. Recommended minimum clearances: side to wall - 2m; rear to wall - 2m control panel end to wall - 1.2m; top - no obstructions whatsoever; distance between adjacent units - 3m. No more than one adjacent wall may be higher than the unit.

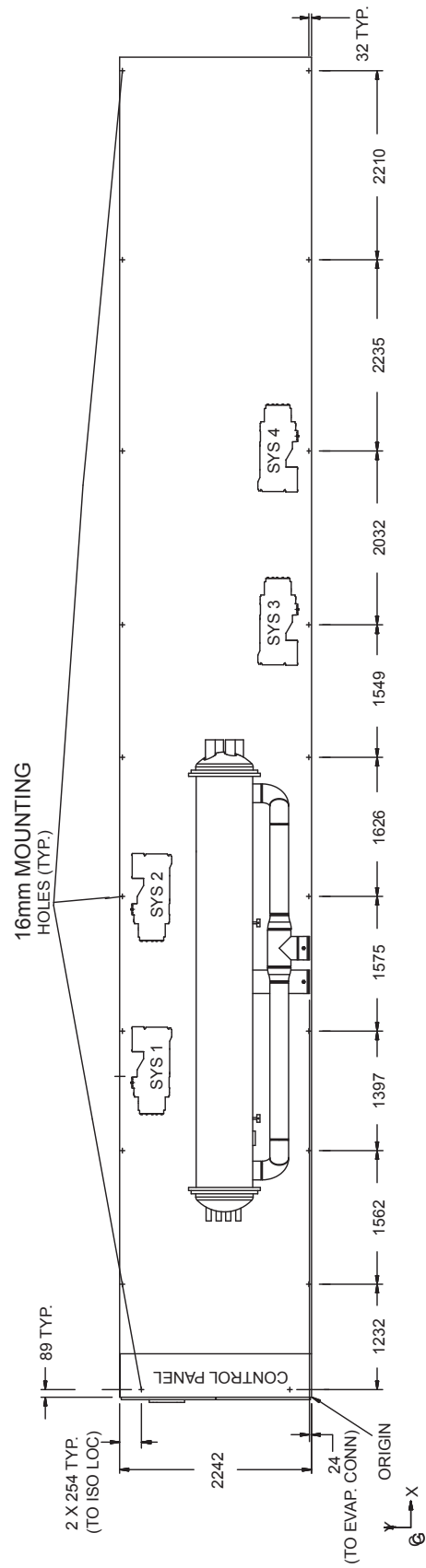

VIEW D-D

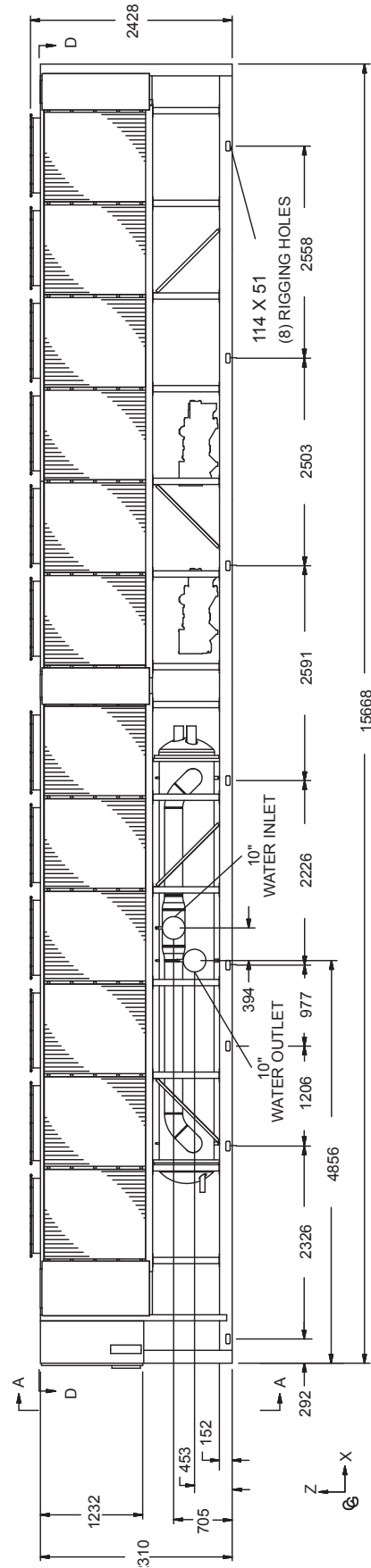

# Isolator Details

## ONE INCH DEFLECTION SPRING ISOLATOR CROSS-REFERENCE

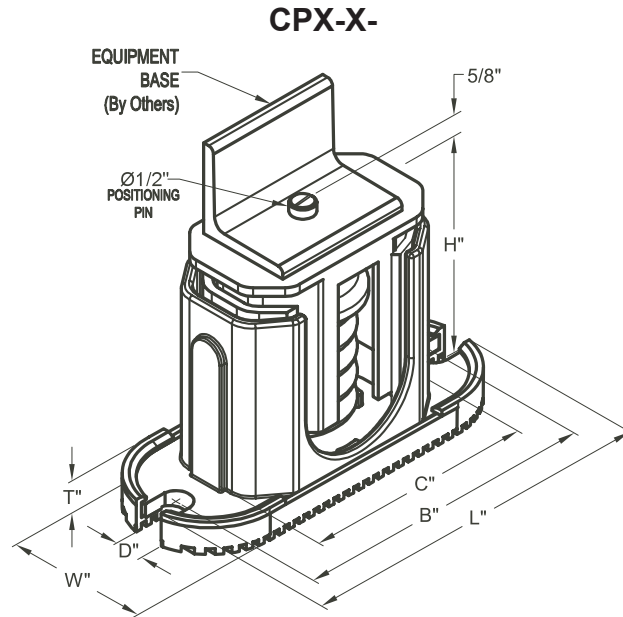

MOUNT TYPE	DIMENSION DATA (INCHES)						
	W	D	L	B	C	T	H
CP	3	5/8	7-3/4	6-1/2	4-3/4	1/2	5-5/8
C2P	3	5/8	10-1/2	9-1/4	7-3/4	9/16	6

MODEL NUMBER	COLOR CODE	RATED CAPACITY (FOR UNITS WITH ALL LOAD POINTS LESS THAN 1785 LBS (810 KG))	
		(LBS.)	(KG)
CP-1D-510	BLACK	Up thru 434	Up thru 197
CP-1D-900	DARK GREEN	435 thru 765	198 thru 347
CP-1D-1200	GRAY	766 thru 1020	348 thru 463
CP-1D-1360	WHITE	1021 thru 1156	464 thru 524
CP-1D-1785N	GRAY/RED	1157 thru 1785	525 thru 810

MODEL NUMBER	COLOR CODE	RATED CAPACITY (FOR UNITS WITH ANY LOAD POINT ABOVE 1518 LBS (689 KG))	
		(LBS.)	(KG)
C2P-1D-1350	DARK PURPLE	Up thru 1148	Up to 521
C2P-1D-1800	DARK GREEN	1149 thru 1530	522 - 694
C2P-1D-2400	GRAY	1531 thru 2040	695 - 925
C2P-1D-2400	GRAY	1531 thru 2040	695 - 925
C2P-1D-2720	WHITE	2041 thru 2312	926 - 1049
C2P-1D-3570N	GRAY/RED	2313 thru 3570	1050 - 1619



**ELASTOMERIC ISOLATOR CROSS-REFERENCE**

**RD-Style Isolators**

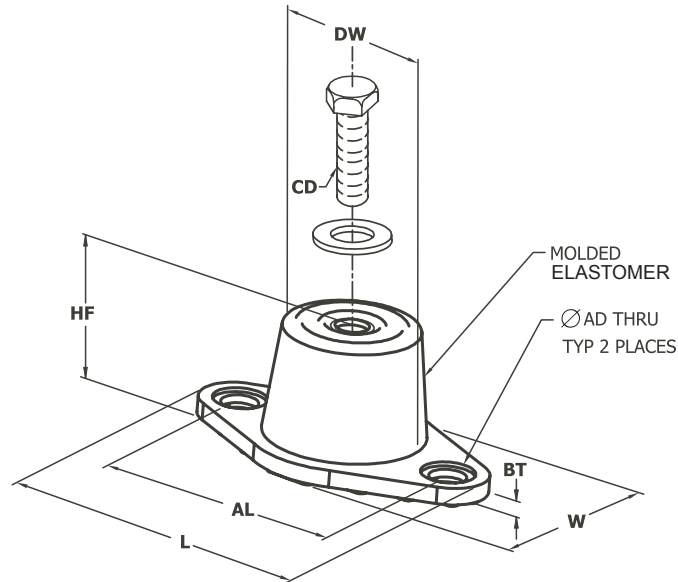

MOUNT TYPE	DIMENSION DATA (INCHES)							
	L	W	HF	AL	AD	BT	CD	DW
RD1-WR	3.13	1.75	1.25	2.38	0.34	0.19	5/16-18 UNC X 3/4	1.25
RD2-WR	3.88	2.38	1.75	3.00	0.34	0.22	3/8-16 UNC X 1	1.75
RD3-WR	5.50	3.38	2.88	4.13	0.56	0.25	1/2-13 UNC X 1	2.50
RD4-WR	6.25	4.63	2.75	5.00	0.56	0.38	1/2-13 UNC X 1	3.00

MODEL NUMBER	ISOLATOR COLOR	WEIGHT RANGE (LBS)	WEIGHT RANGE (KGS)
RD-3-CHARCOAL-WR	CHARCOAL	Up thru 825	UP TO 374
RD-4-BRICK RED-WR	BRICK RED	826 thru 1688	375 - 766
RD-4-CHARCOAL-WR	CHARCOAL	1689 thru 4000	767 - 1814

# Isolator Details - continued

## TWO INCH DEFLECTION, SEISMIC SPRING ISOLATOR CROSS-REFERENCE

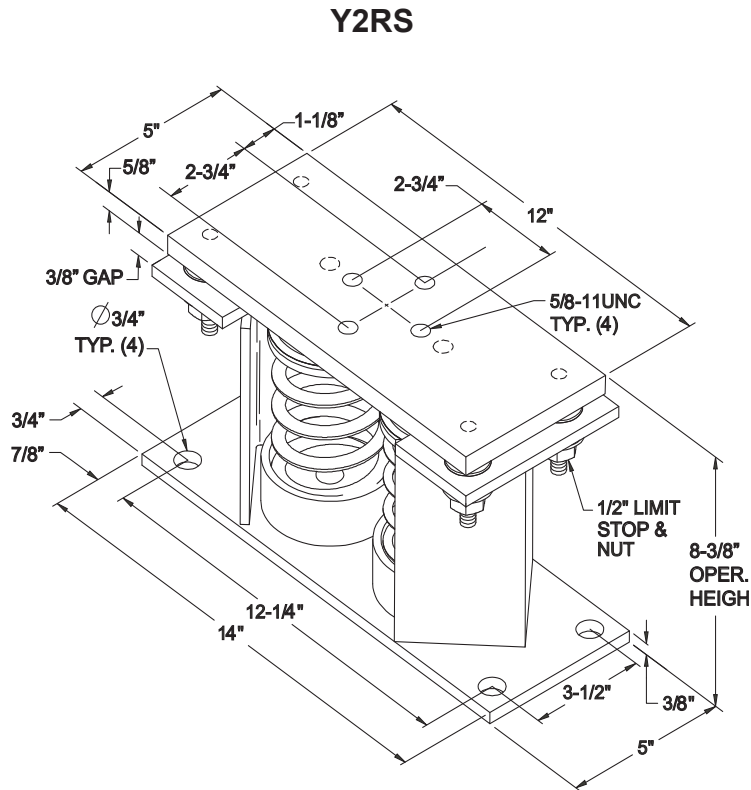

MODEL Y2RSI-2D SEISMICALLY RESTRAINED VIBRATION ISOLATOR FOR 2" DEFLECTION

MODEL NUMBER	ISOL. COLOR	WEIGHT RANGE (LBS)	WEIGHT RANGE (KGS)
Y2RSI-2D-460	GREEN	Up thru 391	UP TO 177
Y2RSI-2D-710	DARK BROWN	392 thru 604	178 - 274
Y2RSI-2D-870	RED	605 thru 740	275 - 336
Y2RSI-2D-1200N	RED/BLACK	741 thru 1020	337 - 463
Y2RSI-2D-1690	PINK	1021 thru 1437	464 - 652
Y2RSI-2D-2640N	PINK/GRAY	1438 thru 2244	653 - 1018
Y2RSI-2D-2870N	PINK/GRAY/ORANGE	2245 thru 2618	1019 - 1188
Y2RSI-2D-3280N	PINK/GRAY/DK.BROWN	2619 thru 3740	1189 - 1696

INTENTIONALLY LEFT BLANK

# Electrical Data - 2 Comp - 60Hz

## STANDARD EFFICIENCY UNITS (SEE FIG. 1)

Model Number /Nameplate			System 1			System 2			Control KVA <sup>8</sup>	Unit Short Circuit Withstand (KA)	
YCAV S/P	Input Volts	Input Freq	Compressor RLA <sup>6</sup>	Cond. Fans		Compressor RLA <sup>6</sup>	Cond. Fans			Terminal Block (STD)	Circuit Breaker (OPT)
				Qty.	FLA (EA)		Qty.	FLA (EA)			
0157	200	60	278	4	6.5	278	4	6.5	1.8	30KA	100KA
	230	60	241	4	5.6	241	4	5.6	1.8	30KA	100KA
	575	60	96	4	2.2	96	4	2.2	1.8	30KA	42KA
0177	200	60	368	4	6.5	244	4	6.5	1.8	30KA	100KA
	230	60	319	4	5.6	211	4	5.6	1.8	30KA	100KA
	575	60	127	4	2.2	84	4	2.2	1.8	30KA	42KA
0187	200	60	376	5	6.5	278	4	6.5	1.8	30KA	100KA
	230	60	325	5	5.6	241	4	5.6	1.8	30KA	100KA
	575	60	130	5	2.2	96	4	2.2	1.8	30KA	42KA
0207	200	60	336	5	6.5	379	4	6.5	1.8	30KA	100KA
	230	60	291	5	5.6	328	4	5.6	1.8	30KA	100KA
	575	60	116	5	2.2	131	4	2.2	1.8	30KA	42KA
0227	200	60	375	5	6.5	375	5	6.5	1.8	30KA	100KA
	230	60	325	5	5.6	325	5	5.6	1.8	30KA	100KA
	575	60	130	5	2.2	130	5	2.2	1.8	30KA	42KA
0247	200	60	448	6	6.5	371	5	6.5	1.8	30KA	100KA
	230	60	388	6	5.6	321	5	5.6	1.8	30KA	100KA
	575	60	155	6	2.2	128	5	2.2	1.8	30KA	42KA
0267	200	60	444	6	6.5	444	6	6.5	1.8	30KA	100KA
	230	60	385	6	5.6	385	6	5.6	1.8	30KA	100KA
	575	60	154	6	2.2	154	6	2.2	1.8	30KA	42KA

See page 142 for Electrical Data footnotes.

## STANDARD EFFICIENCY UNITS (SEE FIG. 1)

YCAV S/P	Field Wiring & Protection				Field Wiring Lugs STD Terminal Block		Field Wiring Lugs OPT Circuit Breaker	
	Minimum Ckt. Ampacity (MCA) <sup>4</sup>	Recommended Fuse/ Ckt. Breaker Rating <sup>5</sup>	Max. Inverse Time Ckt. Brkr. Rating <sup>2</sup>	Max Dual Element Fuse Size <sup>3</sup>	Lugs/ Phase <sup>1</sup>	Lug Wire Range	Lugs/Phase <sub>1</sub>	Lug Wire Range
0157	677	800	1600	1200	4	2AWG - 600 kcmil	4	4/0AWG - 500 kcmil
	587	700	1600	1000	4	2AWG - 600 kcmil	4	4/0AWG - 500 kcmil
	234	300	600	400	2	2AWG - 600 kcmil	2	2/0AWG - 500 kcmil
0177	755	1000	2000	1200	4	2AWG - 600 kcmil	4	4/0AWG - 500 kcmil
	654	800	1600	1200	4	2AWG - 600 kcmil	4	4/0AWG - 500 kcmil
	261	300	600	450	2	2AWG - 600 kcmil	2	2/0AWG - 500 kcmil
0187	805	1000	2000	1600	4	2AWG - 600 kcmil	4	4/0AWG - 500 kcmil
	698	800	1600	1200	4	2AWG - 600 kcmil	4	4/0AWG - 500 kcmil
	279	350	700	450	2	2AWG - 600 kcmil	2	2/0AWG - 500 kcmil
0207	857	1000	2000	1600	4	2AWG - 600 kcmil	4	4/0AWG - 500 kcmil
	742	1000	2000	1200	4	2AWG - 600 kcmil	4	4/0AWG - 500 kcmil
	296	350	700	500	2	2AWG - 600 kcmil	2	2/0AWG - 500 kcmil
0227	908	1200	2000	1600	4	2AWG - 600 kcmil	4	4/0AWG - 500 kcmil
	786	1000	2000	1600	4	2AWG - 600 kcmil	4	4/0AWG - 500 kcmil
	314	350	800	500	2	2AWG - 600 kcmil	2	2/0AWG - 500 kcmil
0247	1002	1200	2000	1600	4	2AWG - 600 kcmil	4	4/0AWG - 500 kcmil
	868	1000	2000	1600	4	2AWG - 600 kcmil	4	4/0AWG - 500 kcmil
	347	400	800	600	2	2AWG - 600 kcmil	2	2/0AWG - 500 kcmil
0267	1076	1200	2000	2000	4	2AWG - 600 kcmil	4	4/0AWG - 500 kcmil
	932	1200	2000	1600	4	2AWG - 600 kcmil	4	4/0AWG - 500 kcmil
	372	450	1000	600	2	2AWG - 600 kcmil	2	2/0AWG - 500 kcmil

# Electrical Data - 2 Comp - 60Hz

## HIGH EFFICIENCY UNITS

Model Number /Nameplate			System 1			System 2			Control KVA <sup>8</sup>	Unit Short Circuit Withstand (KA)	
YCAV E/V	Input Volts	Input Freq	Compressor RLA <sup>6</sup>	Cond. Fans		Compressor RLA <sup>6</sup>	Cond. Fans			Terminal Block (STD)	Circuit Breaker (OPT)
				Qty.	FLA (EA)		Qty.	FLA (EA)			
0157	200	60	254	4	6.5	254	4	6.5	1.8	30KA	100KA
	230	60	220	4	5.6	220	4	5.6	1.8	30KA	100KA
	575	60	88	4	2.2	88	4	2.2	1.8	30KA	42KA
0177	200	60	257	5	6.5	281	4	6.5	1.8	30KA	100KA
	230	60	223	5	5.6	244	4	5.6	1.8	30KA	100KA
	575	60	89	5	2.2	97	4	2.2	1.8	30KA	42KA
0187	200	60	356	5	6.5	242	5	6.5	1.8	30KA	100KA
	230	60	308	5	5.6	210	5	5.6	1.8	30KA	100KA
	575	60	123	5	2.2	84	5	2.2	1.8	30KA	42KA
0197	200	60	326	5	6.5	326	5	6.5	1.8	30KA	100KA
	230	60	283	5	5.6	283	5	5.6	1.8	30KA	100KA
	575	60	113	5	2.2	113	5	2.2	1.8	30KA	42KA
0207	200	60	327	6	6.5	353	5	6.5	1.8	30KA	100KA
	230	60	283	6	5.6	306	5	5.6	1.8	30KA	100KA
	575	60	113	6	2.2	122	5	2.2	1.8	30KA	42KA
0227	200	60	347	6	6.5	347	6	6.5	1.8	30KA	100KA
	230	60	301	6	5.6	301	6	5.6	1.8	30KA	100KA
	575	60	120	6	2.2	120	6	2.2	1.8	30KA	42KA
0247	200	60	449	6	6.5	344	6	6.5	1.8	30KA	100KA
	230	60	389	6	5.6	298	6	5.6	1.8	30KA	100KA
	575	60	155	6	2.2	119	6	2.2	1.8	30KA	42KA

See page 142 for Electrical Data footnotes.

## HIGH EFFICIENCY UNITS

YCAV E/V	Field Wiring & Protection				Field Wiring Lugs		Field Wiring Lugs	
					STD Terminal Block		OPT Circuit Breaker	
	Min Ckt. Ampacity (MCA) <sup>4</sup>	Recommended Fuse/Ckt. Brkr Rating <sup>5</sup>	Max. Inverse Time Ckt. Brkr. Rating <sup>2</sup>	Max Dual Element Fuse Size <sup>3</sup>	Lugs/Phase <sup>1</sup>	Lug Wire Range	Lugs/Phase <sup>1</sup>	Lug Wire Range
0157	624	700	1600	1000	4	2AWG - 600 kcmil	4	4/0AWG - 500 kcmil
	540	600	1600	1000	4	2AWG - 600 kcmil	4	4/0AWG - 500 kcmil
	216	250	500	350	2	2AWG - 600 kcmil	2	2/0AWG - 500 kcmil
0177	661	800	1600	1200	4	2AWG - 600 kcmil	4	4/0AWG - 500 kcmil
	572	700	1600	1000	4	2AWG - 600 kcmil	4	4/0AWG - 500 kcmil
	229	250	600	400	2	2AWG - 600 kcmil	2	2/0AWG - 500 kcmil
0187	751	1000	1600	1200	4	2AWG - 600 kcmil	4	4/0AWG - 500 kcmil
	651	800	1600	1200	4	2AWG - 600 kcmil	4	4/0AWG - 500 kcmil
	260	300	600	450	2	2AWG - 600 kcmil	2	2/0AWG - 500 kcmil
0197	799	1000	1600	1600	4	2AWG - 600 kcmil	4	4/0AWG - 500 kcmil
	692	800	1600	1200	4	2AWG - 600 kcmil	4	4/0AWG - 500 kcmil
	277	350	700	450	2	2AWG - 600 kcmil	2	2/0AWG - 500 kcmil
0207	832	1000	1600	1600	4	2AWG - 600 kcmil	4	4/0AWG - 500 kcmil
	721	800	1600	1200	4	2AWG - 600 kcmil	4	4/0AWG - 500 kcmil
	288	350	700	500	2	2AWG - 600 kcmil	2	2/0AWG - 500 kcmil
0227	859	1000	1600	1600	4	2AWG - 600 kcmil	4	4/0AWG - 500 kcmil
	744	1000	1600	1200	4	2AWG - 600 kcmil	4	4/0AWG - 500 kcmil
	297	350	700	500	2	2AWG - 600 kcmil	2	2/0AWG - 500 kcmil
0247	982	1200	1600	1600	4	2AWG - 600 kcmil	4	4/0AWG - 500 kcmil
	851	1000	1600	1600	4	2AWG - 600 kcmil	4	4/0AWG - 500 kcmil
	340	400	800	600	2	2AWG - 600 kcmil	2	2/0AWG - 500 kcmil

# Electrical Data - 3 Comp - 60Hz

## STANDARD EFFICIENCY

Model No./Nameplate			System 1			System 2			System 3		
			Comp.	Cond. Fans		Comp.	Cond. Fans		Comp.	Cond. Fans	
YCAV	Volts (11)	Freq	RLA (6)	Qty.	FLA (EA)	RLA (6)	Qty.	FLA (EA)	RLA (6)	Qty.	FLA (EA)
0287	575	60	117	5	2.2	131	4	2.2	86	4	2.2
0307	575	60	118	5	2.2	118	5	2.2	132	4	2.2
0357	575	60	129	5	2.2	129	5	2.2	155	6	2.2
0397	575	60	153	6	2.2	153	6	2.2	153	6	2.2

## HIGH EFFICIENCY

Model No./Nameplate			System 1			System 2			System 3		
			Comp.	Cond. Fans		Comp.	Cond. Fans		Comp.	Cond. Fans	
YCAV	Volts (11)	Freq	RLA (6)	Qty.	FLA (EA)	RLA (6)	Qty.	FLA (EA)	RLA (6)	Qty.	FLA (EA)
0267	575	60	114	5	2.2	114	5	2.2	84	4	2.2
0287	575	60	110	5	2.2	110	5	2.2	110	5	2.2
0327	575	60	122	5	2.2	122	5	2.2	113	6	2.2
0357	575	60	146	6	2.2	146	6	2.2	111	6	2.2



## STANDARD EFFICIENCY

Control	Unit Short Circuit Withstand (KA)		Field Wiring & Protection				Field Wiring Lugs STD Terminal Block		Field Wiring Lugs OPT Circuit Breaker	
	KVA (8)	Terminal Block (STD)	Circuit Breaker (OPT)	Minimum Ckt. Ampacity (MCA) (4)	Recommended Fuse/Ckt. Breaker Rating (5)	Max. Inverse Time Ckt. Brkr. Rating (2)	Max Dual Element Fuse Size (3)	Lugs/Phase (1)	Lug Wire Range	Lugs/Phase (1)
2.4	30KA	42KA	396	450	800	700	3	#2 - 600 KCM	3	#3/0 - 400 KCM
2.4	30KA	42KA	433	500	800	800	3	#2 - 600 KCM	3	#3/0 - 400 KCM
2.4	30KA	42KA	487	600	1000	800	3	#2 - 600 KCM	3	#3/0 - 400 KCM
2.4	30KA	42KA	538	600	1000	1000	3	#2 - 600 KCM	3	#3/0 - 400 KCM

## HIGH EFFICIENCY

Control	Unit Short Circuit Withstand (KA)		Field Wiring & Protection				Field Wiring Lugs STD Terminal Block		Field Wiring Lugs OPT Circuit Breaker	
	KVA (8)	Terminal Block (STD)	Circuit Breaker (OPT)	Minimum Ckt. Ampacity (MCA) (4)	Recommended Fuse/Ckt. Breaker Rating (5)	Max. Inverse Time Ckt. Brkr. Rating (2)	Max Dual Element Fuse Size (3)	Lugs/Phase (1)	Lug Wire Range	Lugs/Phase (1)
2.4	30KA	42KA	371	450	800	700	3	#2 - 600 KCM	3	#3/0 - 400 KCM
2.4	30KA	42KA	389	450	800	700	3	#2 - 600 KCM	3	#3/0 - 400 KCM
2.4	30KA	42KA	424	500	800	800	3	#2 - 600 KCM	3	#3/0 - 400 KCM
2.4	30KA	42KA	479	600	1000	800	3	#2 - 600 KCM	3	#3/0 - 400 KCM

# Electrical Data - 4 Comp - 60Hz

## SINGLE POINT WIRING

Standard Efficiency YCAV_____S/P Single Point Wiring																
Model No./Nameplate			System 1			System 2			System 3			System 4			Control	
			Comp.	Cond. Fans		Comp.	Cond. Fans		Comp.	Cond. Fans		Comp.	Cond. Fans		Sys 1/3	Sys 2/4
YCAV	Volts <sup>11</sup>	Freq	RLA <sup>6</sup>	Qty.	FLA (EA)	RLA <sup>6</sup>	Qty.	FLA (EA)	RLA <sup>6</sup>	Qty.	FLA (EA)	RLA <sup>6</sup>	Qty.	FLA (EA)	KVA <sup>8</sup>	KVA <sup>8</sup>
0417	380	60	198	5	3.5	198	5	3.5	198	5	3.5	198	5	3.5	2.4	1.8
	460	60	156	5	2.8	156	5	2.8	156	5	2.8	156	5	2.8	2.4	1.8
	575	60	125	5	2.2	125	5	2.2	125	5	2.2	125	5	2.2	2.4	1.8
0457	380	60	228	6	3.5	228	5	3.5	190	5	3.5	190	5	3.5	2.4	1.8
	460	60	180	6	2.8	180	5	2.8	150	5	2.8	150	5	2.8	2.4	1.8
	575	60	144	6	2.2	144	5	2.2	120	5	2.2	120	5	2.2	2.4	1.8
0477	380	60	244	6	3.5	244	6	3.5	202	5	3.5	202	5	3.5	2.4	1.8
	460	60	193	6	2.8	193	6	2.8	160	5	2.8	160	5	2.8	2.4	1.8
	575	60	155	6	2.2	155	6	2.2	128	5	2.2	128	5	2.2	2.4	1.8
0507	380	60	243	6	3.5	243	6	3.5	202	5	3.5	243	6	3.5	2.4	1.8
	460	60	192	6	2.8	191	6	2.8	159	5	2.8	191	6	2.8	2.4	1.8
	575	60	154	6	2.2	154	6	2.2	128	5	2.2	154	6	2.2	2.4	1.8
0527	380	60	242	6	3.5	242	6	3.5	242	6	3.5	242	6	3.5	2.4	1.8
	460	60	191	6	2.8	191	6	2.8	191	6	2.8	191	6	2.8	2.4	1.8
	575	60	153	6	2.2	153	6	2.2	153	6	2.2	153	6	2.2	2.4	1.8

High Efficiency YCAV_____E/V Single Point																
Model No./Nameplate			System 1			System 2			System 3			System 4			Control	
			Comp.	Cond. Fans		Comp.	Cond. Fans		Comp.	Cond. Fans		Comp.	Cond. Fans		Sys 1/3	Sys 2/4
YCAV	Volts <sup>11</sup>	Freq	RLA <sup>6</sup>	Qty.	FLA (EA)	RLA <sup>6</sup>	Qty.	FLA (EA)	RLA <sup>6</sup>	Qty.	FLA (EA)	RLA <sup>6</sup>	Qty.	FLA (EA)	KVA <sup>8</sup>	KVA <sup>8</sup>
0397	380	60	173	5	3.5	173	5	3.5	173	5	3.5	173	5	3.5	2.4	1.8
	460	60	137	5	2.8	136	5	2.8	137	5	2.8	136	5	2.8	2.4	1.8
	575	60	109	5	2.2	109	5	2.2	109	5	2.2	109	5	2.2	2.4	1.8
0417	380	60	179	6	3.5	179	6	3.5	193	5	3.5	193	5	3.5	2.4	1.8
	460	60	141	6	2.8	141	6	2.8	153	5	2.8	152	5	2.8	2.4	1.8
	575	60	113	6	2.2	113	6	2.2	122	5	2.2	122	5	2.2	2.4	1.8
0477	380	60	231	6	3.5	231	6	3.5	177	6	3.5	177	6	3.5	2.4	1.8
	460	60	182	6	2.8	182	6	2.8	139	6	2.8	139	6	2.8	2.4	1.8
	575	60	146	6	2.2	146	6	2.2	112	6	2.2	112	6	2.2	2.4	1.8

See page 142 for Electrical Data footnotes.

## SINGLE POINT WIRING

Standard Efficiency YCAV_____ S/P Single Point Wiring									
Unit Short Circuit Withstand (KA)		Field Wiring & Protection				Field Wiring Lugs STD Terminal Block		Field Wiring Lugs OPT Circuit Breaker	
Terminal Block (STD)	Circuit Breaker (OPT)	Minimum Ckt. Ampacity (MCA) <sup>4</sup>	Recommended Fuse/Ckt. Breaker Rating <sup>5</sup>	Max. Inverse Time Ckt. Brkr. Rating <sup>2</sup>	Max Dual Element Fuse Size <sup>3</sup>	Lugs/Phase <sup>1</sup>	Lug Wire Range	Lugs/Phase <sup>1</sup>	Lug Wire Range
30KA	65KA	911	1000	2000	1600	4	#1/0-750 KCM	4	#1/0-750 KCM
30KA	65KA	719	800	1600	1200	4	#1/0-750 KCM	4	#1/0-750 KCM
30KA	42KA	577	700	1200	1000	4	#1/0-750 KCM	4	#1/0-750 KCM
30KA	65KA	967	1200	2000	1600	4	#1/0-750 KCM	4	#1/0-750 KCM
30KA	65KA	763	1000	1600	1200	4	#1/0-750 KCM	4	#1/0-750 KCM
30KA	42KA	612	700	1200	1200	4	#1/0-750 KCM	4	#1/0-750 KCM
30KA	65KA	1032	1200	2000	2000	4	#1/0-750 KCM	4	#1/0-750 KCM
30KA	65KA	815	1000	1600	1600	4	#1/0-750 KCM	4	#1/0-750 KCM
30KA	42KA	653	700	1200	1200	4	#1/0-750 KCM	4	#1/0-750 KCM
30KA	65KA	1073	1200	2000	2000	4	#1/0-750 KCM	4	#1/0-750 KCM
30KA	65KA	847	1000	1600	1600	4	#1/0-750 KCM	4	#1/0-750 KCM
30KA	42KA	679	800	1200	1200	4	#1/0-750 KCM	4	#1/0-750 KCM
30KA	65KA	1113	1200	2000	2000	4	#1/0-750 KCM	4	#1/0-750 KCM
30KA	65KA	878	1000	1600	1600	4	#1/0-750 KCM	4	#1/0-750 KCM
30KA	42KA	705	800	1200	1200	4	#1/0-750 KCM	4	#1/0-750 KCM

High Efficiency YCAV_____ E/V Single Point									
Unit Short Circuit Withstand (KA)		Field Wiring & Protection				Field Wiring Lugs STD Terminal Block		Field Wiring Lugs OPT Circuit Breaker	
Terminal Block (STD)	Circuit Breaker (OPT)	Minimum Ckt. Ampacity (MCA) <sup>4</sup>	Recommended Fuse/Ckt. Breaker Rating <sup>5</sup>	Max. Inverse Time Ckt. Brkr. Rating <sup>2</sup>	Max Dual Element Fuse Size <sup>3</sup>	Lugs/Phase <sup>1</sup>	Lug Wire Range	Lugs/Phase <sup>1</sup>	Lug Wire Range
30KA	65KA	805	1000	1600	1600	4	#1/0-750 KCM	4	#1/0-750 KCM
30KA	65KA	636	700	1200	1200	4	#1/0-750 KCM	4	#1/0-750 KCM
30KA	42KA	510	600	1000	1000	4	#1/0-750 KCM	4	#1/0-750 KCM
30KA	65KA	869	1000	1600	1600	4	#1/0-750 KCM	4	#1/0-750 KCM
30KA	65KA	687	800	1200	1200	4	#1/0-750 KCM	4	#1/0-750 KCM
30KA	42KA	551	600	1200	1000	4	#1/0-750 KCM	4	#1/0-750 KCM
30KA	65KA	957	1200	2000	1600	4	#1/0-750 KCM	4	#1/0-750 KCM
30KA	65KA	756	1000	1600	1200	4	#1/0-750 KCM	4	#1/0-750 KCM
30KA	42KA	606	700	1200	1200	4	#1/0-750 KCM	4	#1/0-750 KCM

# Electrical Data - 4 Comp - 60Hz

## DUAL POINT WIRING

Standard Efficiency YCAV___ S/P Dual Point																								
Model No./Nameplate			System 1			System 2			System 3			System 4			Control		Unit Short Circuit Withstand (KA)							
YCAV	Volts <sup>11</sup>	Freq	Comp.		Cond. Fans		Comp.		Cond. Fans		Comp.		Cond. Fans		Comp.		Cond. Fans		Sys 1/3	Sys 2/4	Terminal Blocks (STD)		Circuit Breakers (OPT)	
			RLA <sup>6</sup>	Qty.	FLA (EA)	RLA <sup>6</sup>	Qty.	FLA (EA)	RLA <sup>6</sup>	Qty.	FLA (EA)	RLA <sup>6</sup>	Qty.	FLA (EA)	RLA <sup>6</sup>	Qty.	FLA (EA)	KVA <sup>8</sup>			KVA <sup>8</sup>	Sys 1/3	Sys 2/4	Sys 1/3
			Sys 1/3	Sys 2/4	Sys 1/3	Sys 2/4																		
0417	380	60	198	5	3.5	198	5	3.5	198	5	3.5	198	5	3.5	2.4	1.8	30KA	30KA	65KA	65KA				
	460	60	156	5	2.8	156	5	2.8	156	5	2.8	156	5	2.8	2.4	1.8	30KA	30KA	65KA	65KA				
	575	60	125	5	2.2	125	5	2.2	125	5	2.2	125	5	2.2	2.4	1.8	30KA	30KA	42KA	42KA				
0457	380	60	228	6	3.5	228	5	3.5	190	5	3.5	190	5	3.5	2.4	1.8	30KA	30KA	65KA	65KA				
	460	60	180	6	2.8	180	5	2.8	150	5	2.8	150	5	2.8	2.4	1.8	30KA	30KA	65KA	65KA				
	575	60	144	6	2.2	144	5	2.2	120	5	2.2	120	5	2.2	2.4	1.8	30KA	30KA	42KA	42KA				
0477	380	60	244	6	3.5	244	6	3.5	202	5	3.5	202	5	3.5	2.4	1.8	30KA	30KA	65KA	65KA				
	460	60	193	6	2.8	193	6	2.8	160	5	2.8	160	5	2.8	2.4	1.8	30KA	30KA	65KA	65KA				
	575	60	155	6	2.2	155	6	2.2	128	5	2.2	128	5	2.2	2.4	1.8	30KA	30KA	42KA	42KA				
0507	380	60	243	6	3.5	243	6	3.5	202	5	3.5	243	6	3.5	2.4	1.8	30KA	30KA	65KA	65KA				
	460	60	192	6	2.8	191	6	2.8	159	5	2.8	191	6	2.8	2.4	1.8	30KA	30KA	65KA	65KA				
	575	60	154	6	2.2	154	6	2.2	128	5	2.2	154	6	2.2	2.4	1.8	30KA	30KA	42KA	42KA				
0527	380	60	242	6	3.5	242	6	3.5	242	6	3.5	242	6	3.5	2.4	1.8	30KA	30KA	65KA	65KA				
	460	60	191	6	2.8	191	6	2.8	191	6	2.8	191	6	2.8	2.4	1.8	30KA	30KA	65KA	65KA				
	575	60	153	6	2.2	153	6	2.2	153	6	2.2	153	6	2.2	2.4	1.8	30KA	30KA	42KA	42KA				

High Efficiency YCAV___ E/V Dual Point																								
Model No./Nameplate			System 1			System 2			System 3			System 4			Control		Unit Short Circuit Withstand (KA)							
YCAV	Volts <sup>11</sup>	Freq	Comp.		Cond. Fans		Comp.		Cond. Fans		Comp.		Cond. Fans		Comp.		Cond. Fans		Sys 1/3	Sys 2/4	Terminal Blocks (STD)		Circuit Breakers (OPT)	
			RLA <sup>6</sup>	Qty.	FLA (EA)	RLA <sup>6</sup>	Qty.	FLA (EA)	RLA <sup>6</sup>	Qty.	FLA (EA)	RLA <sup>6</sup>	Qty.	FLA (EA)	RLA <sup>6</sup>	Qty.	FLA (EA)	KVA <sup>8</sup>			KVA <sup>8</sup>	Sys 1/3	Sys 2/4	Sys 1/3
			Sys 1/3	Sys 2/4	Sys 1/3	Sys 2/4																		
0397	380	60	173	5	3.5	173	5	3.5	173	5	3.5	173	5	3.5	2.4	1.8	30KA	30KA	65KA	65KA				
	460	60	137	5	2.8	136	5	2.8	137	5	2.8	136	5	2.8	2.4	1.8	30KA	30KA	65KA	65KA				
	575	60	109	5	2.2	109	5	2.2	109	5	2.2	109	5	2.2	2.4	1.8	30KA	30KA	42KA	42KA				
0417	380	60	179	6	3.5	179	6	3.5	193	5	3.5	193	5	3.5	2.4	1.8	30KA	30KA	65KA	65KA				
	460	60	141	6	2.8	141	6	2.8	153	5	2.8	152	5	2.8	2.4	1.8	30KA	30KA	65KA	65KA				
	575	60	113	6	2.2	113	6	2.2	122	5	2.2	122	5	2.2	2.4	1.8	30KA	30KA	42KA	42KA				
0477	380	60	231	6	3.5	231	6	3.5	177	6	3.5	177	6	3.5	2.4	1.8	30KA	30KA	65KA	65KA				
	460	60	182	6	2.8	182	6	2.8	139	6	2.8	139	6	2.8	2.4	1.8	30KA	30KA	65KA	65KA				
	575	60	146	6	2.2	146	6	2.2	112	6	2.2	112	6	2.2	2.4	1.8	30KA	30KA	42KA	42KA				

See page 96 for Electrical Data footnotes.

## DUAL POINT WIRING

Standard Efficiency YCAV\_\_\_\_ S/P Dual Point

Field Wiring & Protection								Field Wiring Lugs				Field Wiring Lugs			
								STD Terminal Blocks				OPT Circuit Breakers			
Minimum Ckt. Ampacity (MCA) <sup>4</sup>		Recommended Fuse/Ckt. Breaker Rating <sup>5</sup>		Max. Inverse Time Ckt. Brkr. Rating <sup>2</sup>		Max Dual Element Fuse Size <sup>3</sup>		Lugs/Phase <sup>1</sup>		Lug Wire Range		Lugs/Phase <sup>(1)</sup>		Lug Wire Range	
Sys 1/3	Sys 2/4	Sys 1/3	Sys 2/4	Sys 1/3	Sys 2/4	Sys 1/3	Sys 2/4	Sys 1/3	Sys 2/4	Sys 1/3	Sys 2/4	Sys 1/3	Sys 2/4	Sys 1/3	Sys 2/4
480	480	600	600	1000	1000	800	800	3	3	#2-600 KCM	#2-600 KCM	3	3	#3/0-400 KCM	#3/0-400 KCM
379	379	450	450	800	800	700	700	2	2	#2-600 KCM	#2-600 KCM	2	2	#2/0-500 KCM	#2/0-500 KCM
304	304	350	350	600	600	500	500	2	2	#2-600 KCM	#2-600 KCM	2	2	#2/0-500 KCM	#2/0-500 KCM
514	510	600	600	1000	1000	800	800	3	3	#2-600 KCM	#2-600 KCM	3	3	#2/0-500 KCM	#2/0-500 KCM
406	403	500	500	800	800	700	700	2	2	#2-600 KCM	#2-600 KCM	2	2	#2/0-500 KCM	#2/0-500 KCM
325	323	400	400	600	600	600	600	2	2	#2-600 KCM	#2-600 KCM	2	2	#2/0-500 KCM	#2/0-500 KCM
546	546	700	700	1000	1000	1000	1000	3	3	#2-600 KCM	#2-600 KCM	3	3	#3/0-400 KCM	#3/0-400 KCM
431	431	500	500	800	800	800	800	2	2	#2-600 KCM	#2-600 KCM	2	2	#2/0-500 KCM	#2/0-500 KCM
346	346	400	400	700	700	600	600	2	2	#2-600 KCM	#2-600 KCM	2	2	#2/0-500 KCM	#2/0-500 KCM
545	588	700	700	1000	1200	1000	1000	3	3	#2-600 KCM	#2-600 KCM	3	3	#3/0-400 KCM	#3/0-400 KCM
430	464	500	600	800	800	800	800	2	2	#2-600 KCM	#2-600 KCM	2	2	#2/0-500 KCM	#2/0-500 KCM
345	372	400	450	700	700	600	700	2	2	#2-600 KCM	#2-600 KCM	2	2	#2/0-500 KCM	#2/0-500 KCM
587	587	700	700	1200	1200	1000	1000	3	3	#2-600 KCM	#2-600 KCM	3	3	#3/0-400 KCM	#3/0-400 KCM
463	463	600	600	800	800	800	800	2	2	#2-600 KCM	#2-600 KCM	2	2	#2/0-500 KCM	#2/0-500 KCM
372	372	450	450	700	700	700	700	2	2	#2-600 KCM	#2-600 KCM	2	2	#2/0-500 KCM	#2/0-500 KCM

High Efficiency YCAV\_\_\_\_ E/V Dual Point

Field Wiring & Protection								Field Wiring Lugs				Field Wiring Lugs			
								STD Terminal Blocks				OPT Circuit Breakers			
Minimum Ckt. Ampacity (MCA) <sup>4</sup>		Recommended Fuse/Ckt. Breaker Rating <sup>5</sup>		Max. Inverse Time Ckt. Brkr. Rating <sup>2</sup>		Max Dual Element Fuse Size <sup>3</sup>		Lugs/Phase <sup>1</sup>		Lug Wire Range		Lugs/Phase <sup>1</sup>		Lug Wire Range	
Sys 1/3	Sys 2/4	Sys 1/3	Sys 2/4	Sys 1/3	Sys 2/4	Sys 1/3	Sys 2/4	Sys 1/3	Sys 2/4	Sys 1/3	Sys 2/4	Sys 1/3	Sys 2/4	Sys 1/3	Sys 2/4
424	424	500	500	800	800	800	800	3	3	#2-600 KCM	#2-600 KCM	3	3	#3/0-400 KCM	#3/0-400 KCM
335	335	400	400	700	700	600	600	2	2	#2-600 KCM	#2-600 KCM	2	2	#2/0-500 KCM	#2/0-500 KCM
269	269	300	300	500	500	500	500	2	2	#2-600 KCM	#2-600 KCM	2	2	#2/0-500 KCM	#2/0-500 KCM
459	459	600	600	800	800	800	800	3	3	#2-600 KCM	#2-600 KCM	3	3	#3/0-400 KCM	#3/0-400 KCM
362	362	450	450	700	700	600	600	2	2	#2-600 KCM	#2-600 KCM	2	2	#2/0-500 KCM	#2/0-500 KCM
291	291	350	350	600	600	500	500	2	2	#2-600 KCM	#2-600 KCM	2	2	#2/0-500 KCM	#2/0-500 KCM
507	507	600	600	1000	1000	800	800	3	3	#2-600 KCM	#2-600 KCM	3	3	#3/0-400 KCM	#3/0-400 KCM
401	401	500	450	800	800	700	700	2	2	#2-600 KCM	#2-600 KCM	2	2	#2/0-500 KCM	#2/0-500 KCM
321	321	400	400	600	600	600	600	2	2	#2-600 KCM	#2-600 KCM	2	2	#2/0-500 KCM	#2/0-500 KCM

# Electrical Data - 4 Comp - 50Hz

## STANDARD EFFICIENCY - 4 COMPRESSOR UNITS (SEE FIG. 1) - Dual Point

Model No./Nameplate			System 1			System 2			System 3			System 4			Control		Unit Short Circuit Withstand (KA)			
			Comp.	Cond. Fans		Comp.	Cond. Fans		Comp.	Cond. Fans		Comp.	Cond. Fans		Sys 1/3	Sys 2/4				
YCAV	Volts (11)	Freq	RLA (6)	Qty.	FLA (Ea)	RLA (6)	Qty.	FLA (Ea)	RLA (6)	Qty.	FLA (Ea)	RLA (6)	Qty.	FLA (Ea)	KVA (8)	KVA (8)	Terminal Blocks (STD)		Circuit Breakers (OPT)	
			Sys 1/3	Sys 2/4	Sys 1/3	Sys 2/4														
1549	400	50	188	5	3.4	188	5	3.4	188	5	3.4	188	5	3.4	2.4	1.8	30KA	30KA	65KA	65KA
1649	400	50	216	6	3.4	216	5	3.4	181	5	3.4	181	5	3.4	2.4	1.8	30KA	30KA	65KA	65KA
1739	400	50	232	6	3.4	232	6	3.4	192	5	3.4	192	5	3.4	2.4	1.8	30KA	30KA	65KA	65KA
1829	400	50	231	6	3.4	230	6	3.4	192	5	3.4	230	6	3.4	2.4	1.8	30KA	30KA	65KA	65KA
1909	400	50	230	6	3.4	230	6	3.4	230	6	3.4	230	6	3.4	2.4	1.8	30KA	30KA	65KA	65KA

## STANDARD EFFICIENCY - 4 COMPRESSOR UNITS (SEE FIG. 1) - Single Point

Model No./nameplate			System 1			System 2			System 3			System 4			Control		Unit Short Circuit Withstand (Ka)	
			Comp.	Cond. Fans		Comp.	Cond. Fans		Comp.	Cond. Fans		Comp.	Cond. Fans		Sys 1/3	Sys 2/4		
Ycav	Volts (11)	Freq	Rla (6)	Qty.	Fla (Ea)	Rla (6)	Qty.	Fla (Ea)	Rla (6)	Qty.	Fla (Ea)	Rla (6)	Qty.	Fla (Ea)	Kva (8)	Kva (8)	Terminal Block (Std)	Circuit Breaker (Opt)
			1549	400	50	188	5	3.4	188	5	3.4	188	5	3.4	188	5	3.4	2.4
1649	400	50	216	6	3.4	216	5	3.4	181	5	3.4	181	5	3.4	2.4	1.8	30KA	65KA
1739	400	50	232	6	3.4	232	6	3.4	192	5	3.4	192	5	3.4	2.4	1.8	30KA	65KA
1829	400	50	231	6	3.4	230	6	3.4	192	5	3.4	230	6	3.4	2.4	1.8	30KA	65KA
1909	400	50	230	6	3.4	230	6	3.4	230	6	3.4	230	6	3.4	2.4	1.8	30KA	65KA

## HIGH EFFICIENCY 4-Compressor Units - Dual Point

Model No./Nameplate			System 1			System 2			System 3			System 4			Control		Unit Short Circuit Withstand (KA)			
			Comp.	Cond. Fans		Comp.	Cond. Fans		Comp.	Cond. Fans		Comp.	Cond. Fans		Sys 1/3	Sys 2/4				
YCAV	Volts (11)	Freq	RLA (6)	Qty.	FLA (EA)	RLA (6)	Qty.	FLA (EA)	RLA (6)	Qty.	FLA (EA)	RLA (6)	Qty.	FLA (EA)	KVA (8)	KVA (8)	Terminal Blocks (STD)		Circuit Breakers (OPT)	
			Sys 1/3	Sys 2/4	Sys 1/3	Sys 2/4														
1429	400	50	164	5	3.4	164	5	3.4	164	5	3.4	164	5	3.4	2.4	1.8	30KA	30KA	65KA	65KA
1549	400	50	170	6	3.4	170	6	3.4	183	5	3.4	183	5	3.4	2.4	1.8	30KA	30KA	65KA	65KA
1739	400	50	219	6	3.4	219	6	3.4	168	6	3.4	168	6	3.4	2.4	1.8	30KA	30KA	65KA	65KA

## HIGH EFFICIENCY 4-Compressor Units - Single Point

Model No./Nameplate			System 1			System 2			System 3			System 4			Control		Unit Short Circuit Withstand (KA)	
			Comp.	Cond. Fans		Comp.	Cond. Fans		Comp.	Cond. Fans		Comp.	Cond. Fans		Sys 1/3	Sys 2/4		
YCAV	Volts (11)	Freq	RLA (6)	Qty.	FLA (EA)	RLA (6)	Qty.	FLA (EA)	RLA (6)	Qty.	FLA (EA)	RLA (6)	Qty.	FLA (EA)	KVA (8)	KVA (8)	Terminal Block (STD)	Circuit Breaker (OPT)
			1429	400	50	164	5	3.4	164	5	3.4	164	5	3.4	164	5	3.4	2.4
1549	400	50	170	6	3.4	170	6	3.4	183	5	3.4	183	5	3.4	2.4	1.8	30KA	65KA
1739	400	50	219	6	3.4	219	6	3.4	168	6	3.4	168	6	3.4	2.4	1.8	30KA	65KA

See page 142 for Electrical Data footnotes.

**STANDARD EFFICIENCY - 4 COMPRESSOR UNITS (SEE FIG. 1) - Dual Point**

Field Wiring & Protection								Field Wiring Lugs STD Terminal Blocks				Field Wiring Lugs OPT Circuit Breakers			
Minimum Ckt. Ampacity (MCA) (4)		Recommended Fuse/Ckt. Breaker Rating (5)		Max. Inverse Time Ckt. Brkr. Rating (2)		Max Dual Element Fuse Size (3)		Lugs/Phase (1)		Lug Wire Range		Lugs/Phase (1)		Lug Wire Range	
Sys 1/3	Sys 2/4	Sys 1/3	Sys 2/4	Sys 1/3	Sys 2/4	Sys 1/3	Sys 2/4	Sys 1/3	Sys 2/4	Sys 1/3	Sys 2/4	Sys 1/3	Sys 2/4	Sys 1/3	Sys 2/4
456	456	600	600	800	800	800	800	3	3	#2-600 KCM	#2-600 KCM	3	3	#3/0-400 KCM	#3/0-400 KCM
488	484	600	600	1000	1000	800	800	3	3	#2-600 KCM	#2-600 KCM	3	3	#3/0-400 KCM	#3/0-400 KCM
519	519	600	600	1000	1000	800	800	3	3	#2-600 KCM	#2-600 KCM	3	3	#3/0-400 KCM	#3/0-400 KCM
518	558	600	700	1000	1000	800	1000	3	3	#2-600 KCM	#2-600 KCM	3	3	#3/0-400 KCM	#3/0-400 KCM
557	557	700	700	1000	1000	1000	1000	3	3	#2-600 KCM	#2-600 KCM	3	3	#3/0-400 KCM	#3/0-400 KCM

**STANDARD EFFICIENCY - 4 COMPRESSOR UNITS (SEE FIG. 1) - Single Point**

Field Wiring & Protection				Field Wiring Lugs Std Terminal Block		Field Wiring Lugs Opt Circuit Breaker	
Minimum Ckt. Ampacity (Mca) (4)	Recommended Fuse/ckt. Breaker Rating (5)	Max. Inverse Time Ckt. Brkr. Rating (2)	Max Dual Element Fuse Size (3)	Lugs/phase (1)	Lug Wire Range	Lugs/phase (1)	Lug Wire Range
865	1000	1600	1600	4	#1/0-750 KCM	4	#1/0-750 KCM
918	1000	2000	1600	4	#1/0-750 KCM	4	#1/0-750 KCM
980	1200	2000	1600	4	#1/0-750 KCM	4	#1/0-750 KCM
1018	1200	2000	2000	4	#1/0-750 KCM	4	#1/0-750 KCM
1057	1200	2000	2000	4	#1/0-750 KCM	4	#1/0-750 KCM

**HIGH EFFICIENCY 4-Compressor Units - Dual Point**

Field Wiring & Protection								Field Wiring Lugs STD Terminal Blocks				Field Wiring Lugs OPT Circuit Breakers			
Minimum Ckt. Ampacity (MCA) (4)		Recommended Fuse/Ckt. Breaker Rating (5)		Max. Inverse Time Ckt. Brkr. Rating (2)		Max Dual Element Fuse Size (3)		Lugs/Phase (1)		Lug Wire Range		Lugs/Phase (1)		Lug Wire Range	
Sys 1/3	Sys 2/4	Sys 1/3	Sys 2/4	Sys 1/3	Sys 2/4	Sys 1/3	Sys 2/4	Sys 1/3	Sys 2/4	Sys 1/3	Sys 2/4	Sys 1/3	Sys 2/4	Sys 1/3	Sys 2/4
403	403	450	450	800	800	700	700	3	3	#2-600 KCM	#2-600 KCM	3	3	#3/0-400 KCM	#3/0-400 KCM
436	436	500	500	800	800	800	800	3	3	#2-600 KCM	#2-600 KCM	3	3	#3/0-400 KCM	#3/0-400 KCM
482	482	600	600	1000	1000	800	800	3	3	#2-600 KCM	#2-600 KCM	3	3	#3/0-400 KCM	#3/0-400 KCM

**HIGH EFFICIENCY 4-Compressor Units - Single Point**

Field Wiring & Protection				Field Wiring Lugs STD Terminal Block		Field Wiring Lugs OPT Circuit Breaker	
Minimum Ckt. Ampacity (MCA) (4)	Recommended Fuse/Ckt. Breaker Rating (5)	Max. Inverse Time Ckt. Brkr. Rating (2)	Max Dual Element Fuse Size (3)	Lugs/Phase (1)	Lug Wire Range	Lugs/Phase (1)	Lug Wire Range
765	1000	1600	1200	4	#1/0-750 KCM	4	#1/0-750 KCM
826	1000	1600	1600	4	#1/0-750 KCM	4	#1/0-750 KCM
909	1000	2000	1600	4	#1/0-750 KCM	4	#1/0-750 KCM

# Electrical Notes

- As standard, all units have single point power connection for two and three compressor systems and dual point for four compressor systems (with single point as an option). Contact factory for information regarding dual point power units.
- Maximum Inverse Time Circuit Breaker - 250% of the rated input current of the drive per NEC 430.52 (C1).
- Maximum Dual Element (Time Delay) Fuse - 225% of the rated input current of the drive per NEC 430.52 (C1).
- MCA - Minimum Circuit Ampacity - 125% of the largest compressor RLA plus 100% of the remaining compressor RLA's plus the sum of all condenser fan FLA's per NEC 440.33
- Recommended time delay or dual element fuse size - 150% of the largest compressor RLA plus 100% of the remaining compressor RLA's plus the sum of all condenser fan FLA's.
- RLA - Rated Load Amps - rated in accordance with UL standard 1995.
- Local codes may take precedence.
- Control KVA includes operational controls and evaporator heaters.
- System inrush current is less than RLA due to the use of Johnson Controls Variable-speed drive technology. Typical compressor starting current (in the first four seconds of startup):

Rated Voltage	Typical Starting Current per Compressor
200/60/3	53A
230/60/3	46A
380/60/3	29A
460/60/3	23A
575/60/3	18A
400/50/3	28A

- Optional Compressor Service Disconnect switch is available on all units.

- Voltage Utilization Range:

Rated Voltage	Utilization Range
200/60/3	180-220
230/60/3	208-254
380/60/3	342-402
460/60/3	414-508
575/60/3	520-635
400/50/3	360-440

- Condenser fan FLA applies to both low sound and ultra quiet fans.

## LEGEND

CB	CIRCUIT BREAKER
DE	DUAL ELEMENT FUSE
DISC SW	DISCONNECT SWITCH
FACT CB	FACTORY-MOUNTED CIRCUIT BREAKER
FLA	FULL LOAD AMPS
HZ	HERTZ
MAX	MAXIMUM
MCA	MINIMUM CIRCUIT AMPACITY
MIN	MINIMUM
MIN NF	MINIMUM NON-FUSED
RLA	RATED LOAD AMPS
SP WIRE	SINGLE-POINT WIRING

## NOTES:

- U.L. Label is provided on 60 Hz units for these electrical wiring configurations.
- — — — — Dashed Line = Field Provided Wiring.
- The above recommendations are based on the National Electric Code and using copper conductors only. Field wiring must also comply with local codes. Group Rated breaker must be HACR type for cUL machines.



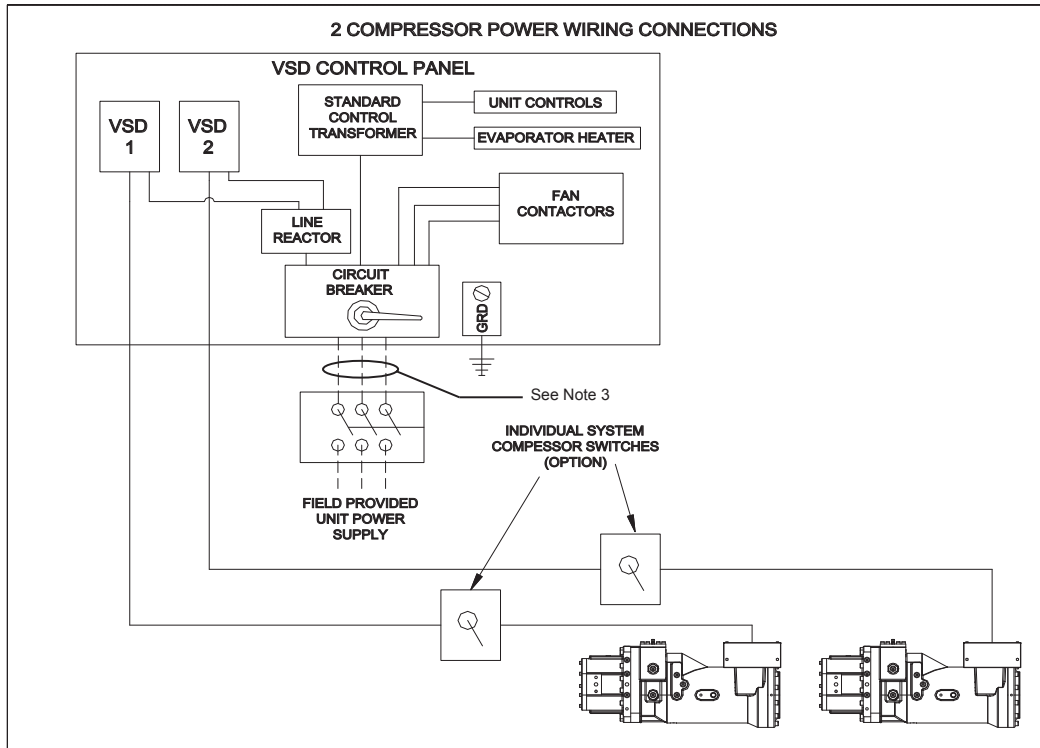

FIG. 1 – TWO COMPRESSOR WIRING DIAGRAM WITH CIRCUIT BREAKER

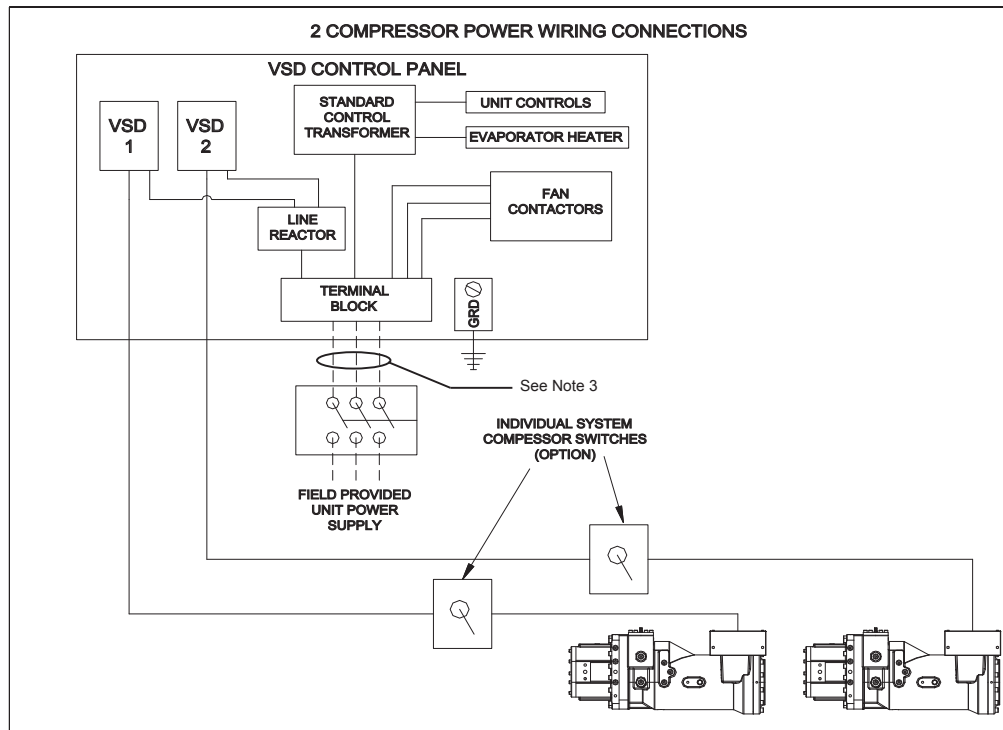

FIG. 2 – TWO COMPRESSOR WIRING DIAGRAM WITH TERMINAL BLOCK

# Power Wiring - continued

3 COMPRESSOR POWER WIRING CONNECTIONS

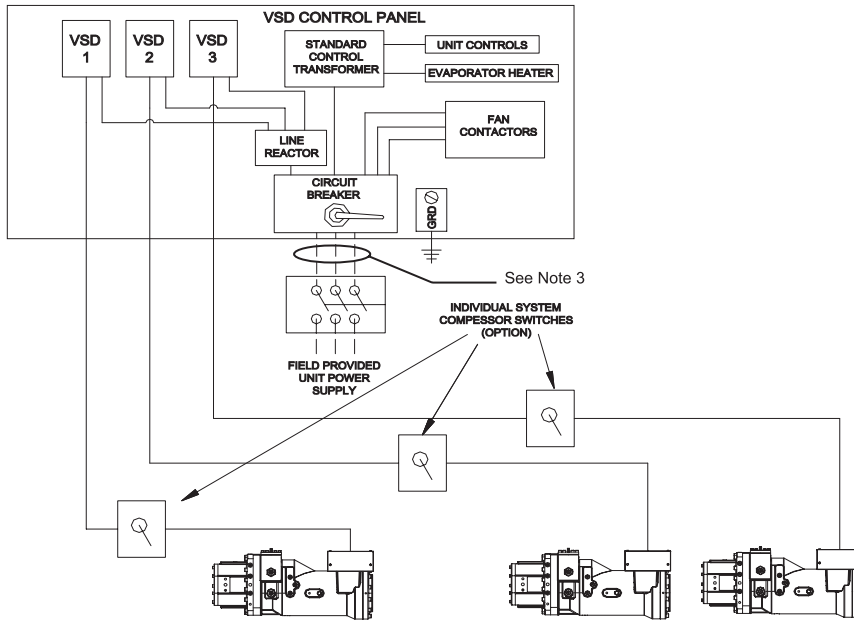

FIG. 3 – THREE COMPRESSOR WIRING DIAGRAM WITH CIRCUIT BREAKER – SINGLE POINT

3 COMPRESSOR POWER WIRING CONNECTIONS

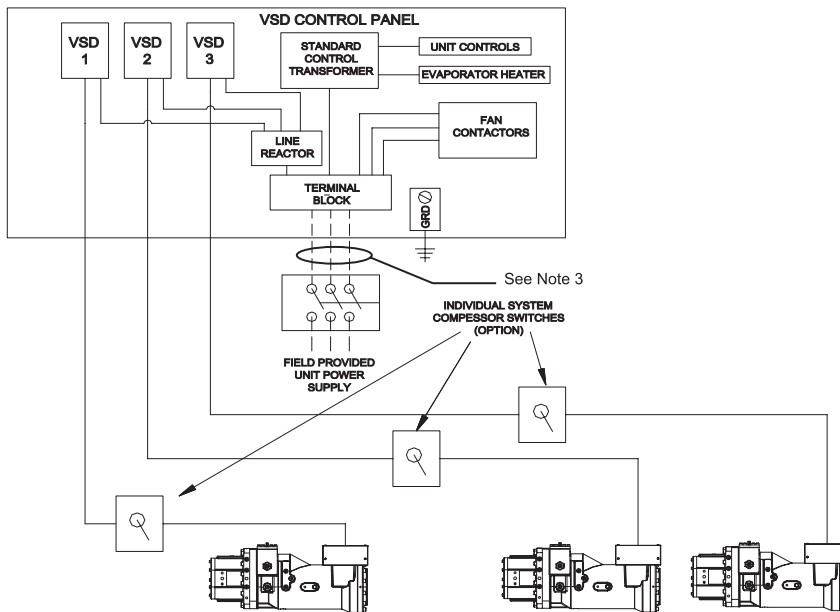

FIG. 4 – THREE COMPRESSOR WIRING DIAGRAM WITH TERMINAL BLOCK – SINGLE POINT

4 COMPRESSOR POWER WIRING CONNECTIONS

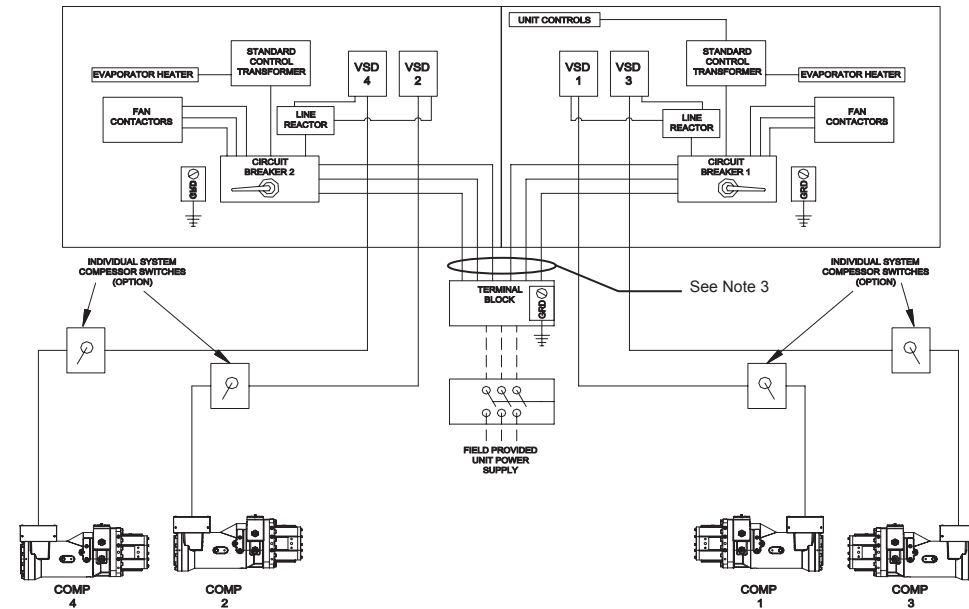

FIG. 5 – FOUR COMPRESSOR WIRING DIAGRAM WITH CIRCUIT BREAKER – SINGLE POINT

4 COMPRESSOR POWER WIRING CONNECTIONS

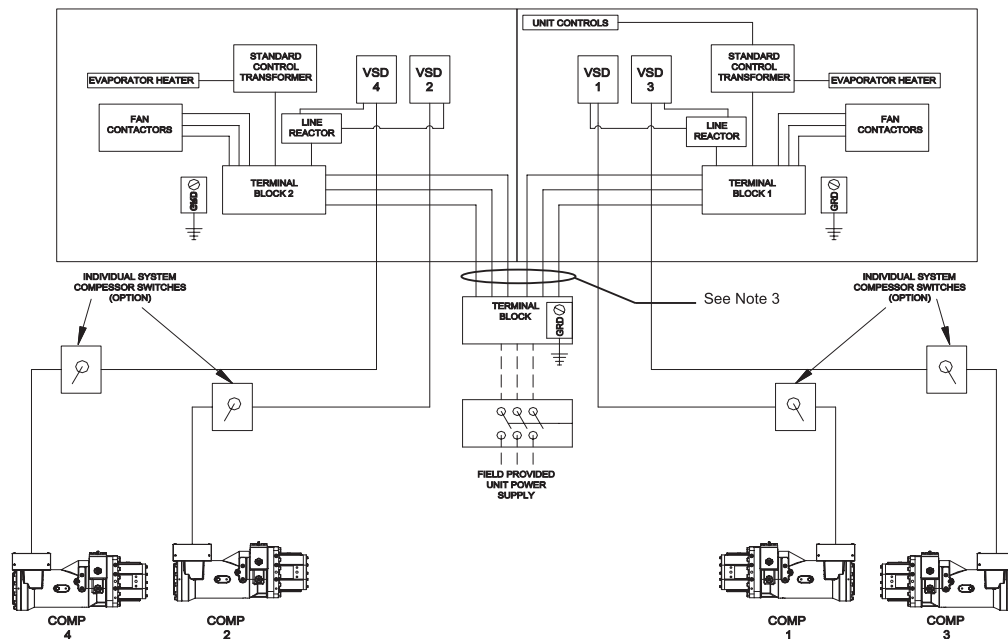

FIG. 6 – FOUR COMPRESSOR WIRING DIAGRAM WITH TERMINAL BLOCK – SINGLE POINT

# Power Wiring - continued

## 4 COMPRESSOR POWER WIRING CONNECTIONS

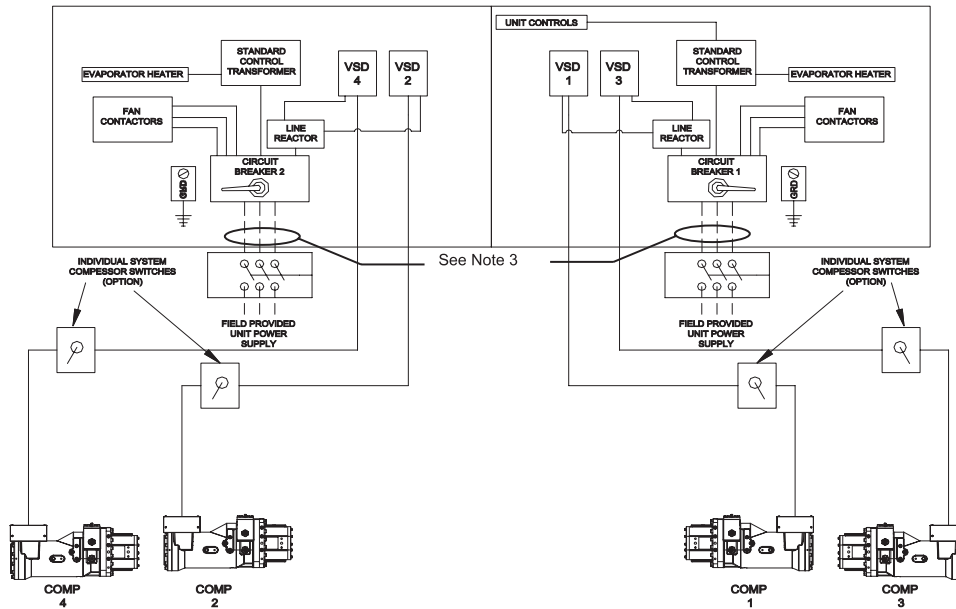

FIG. 7 – FOUR COMPRESSOR WIRING DIAGRAM WITH CIRCUIT BREAKER – MULTI POINT

## 4 COMPRESSOR POWER WIRING CONNECTIONS

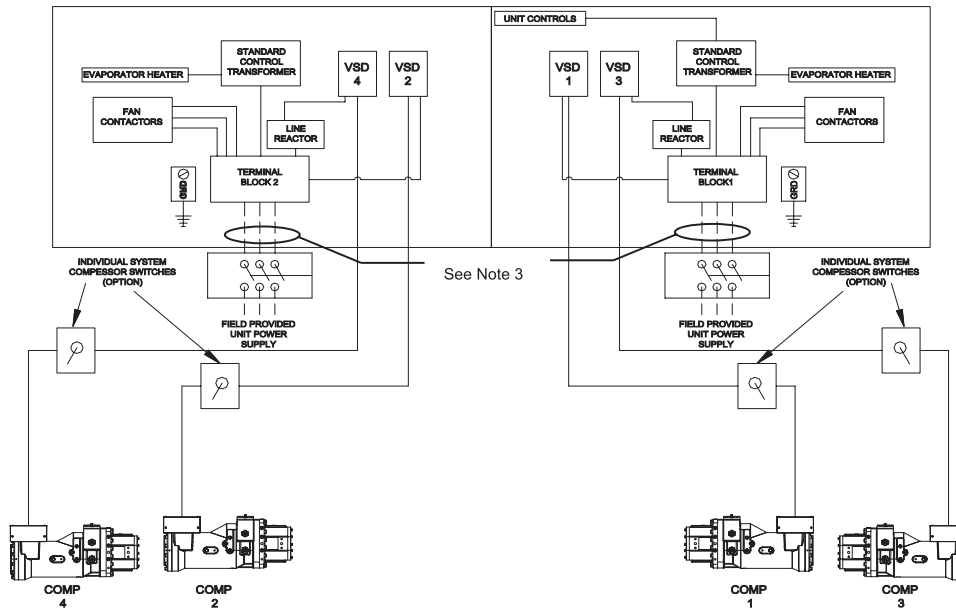
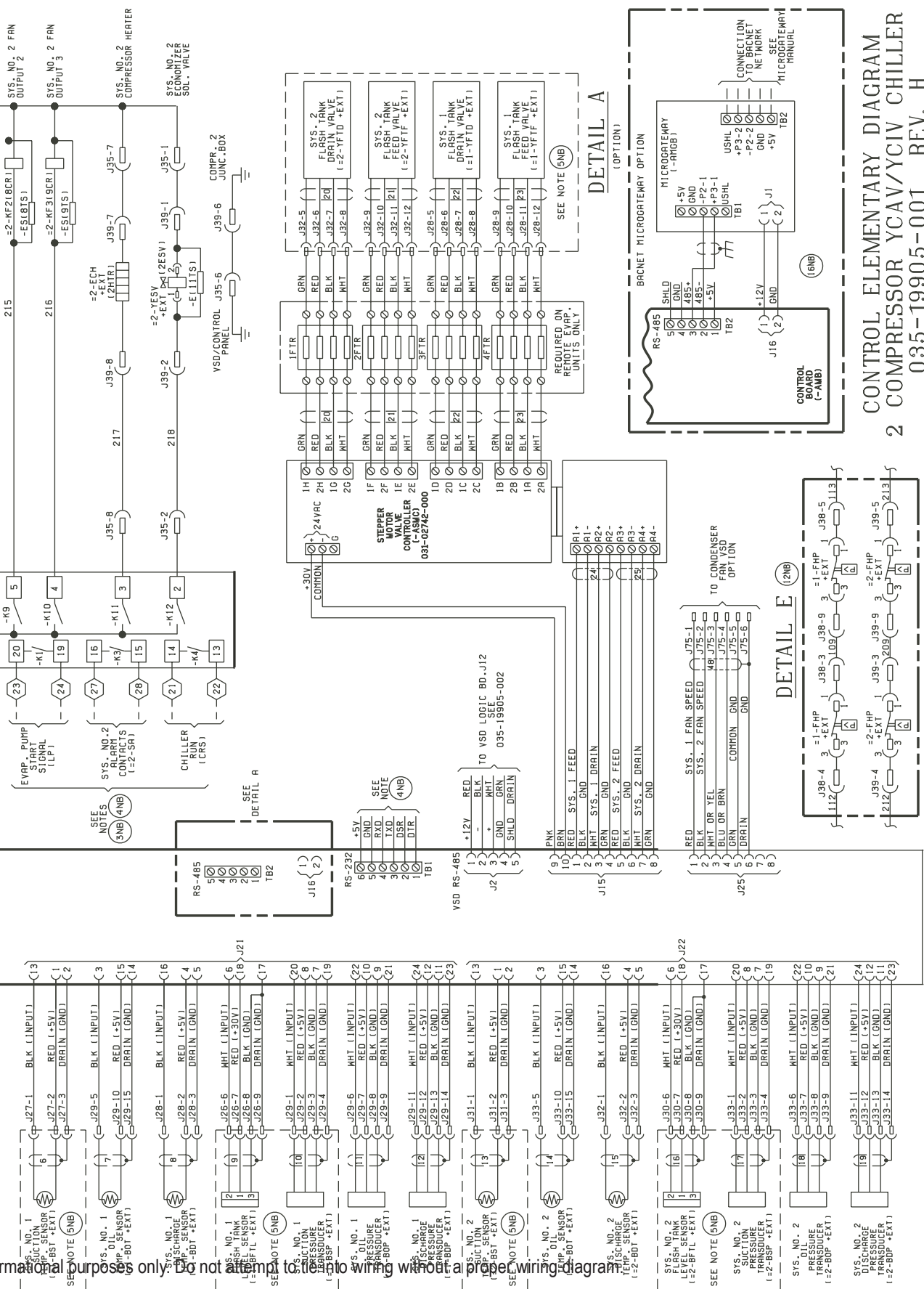

FIG. 8 – FOUR COMPRESSOR WIRING DIAGRAM WITH TERMINAL BLOCK – MULTI POINT

INTENTIONALLY LEFT BLANK



For informational purposes only. Do not attempt to rewire without a proper wiring diagram.



CONTROL ELEMENTARY DIAGRAM  
2 COMPRESSOR YCAV/YCIV CHILLER  
035-19905-001 REV. H

# Typical Control Wiring - Three Compressor

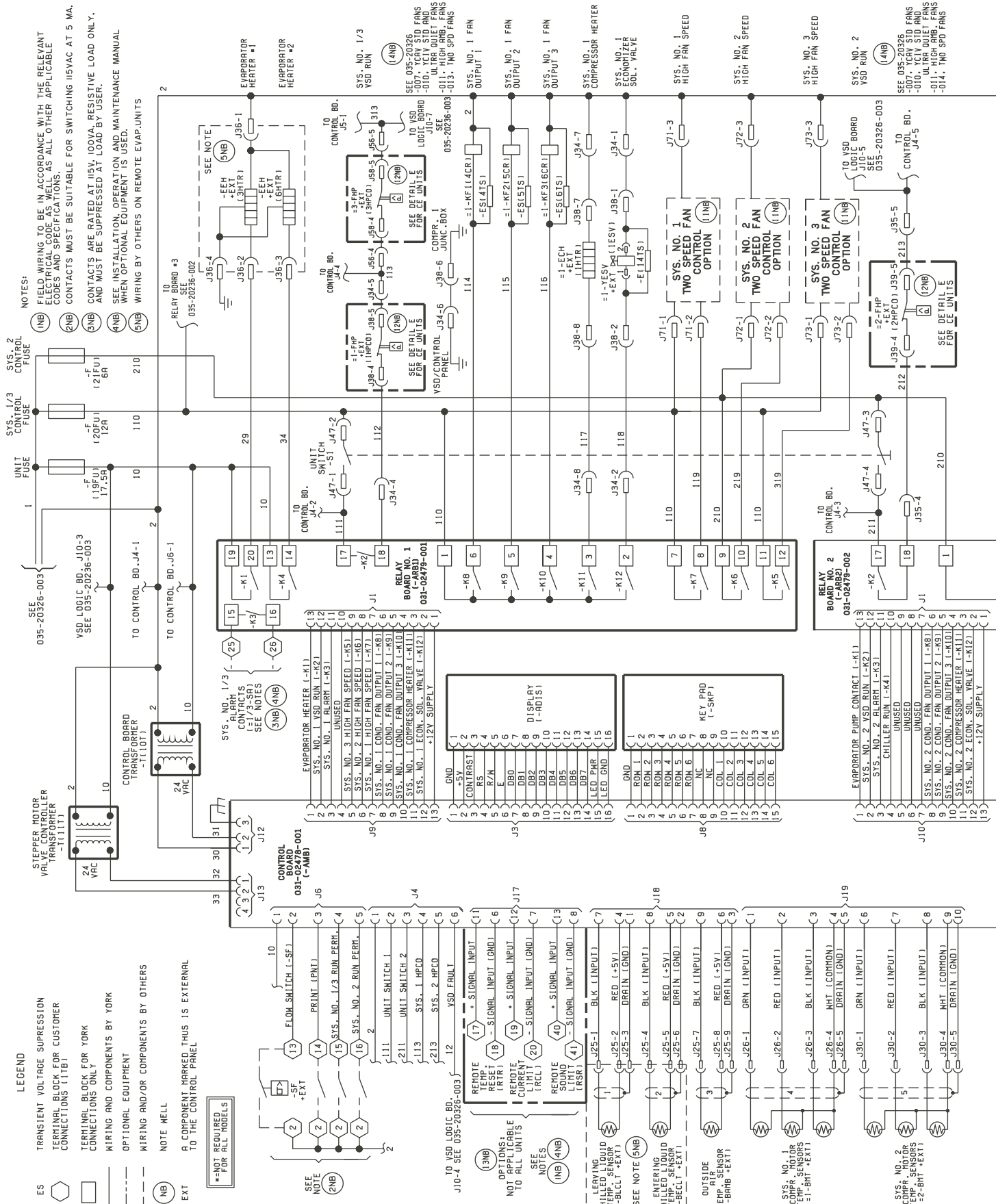



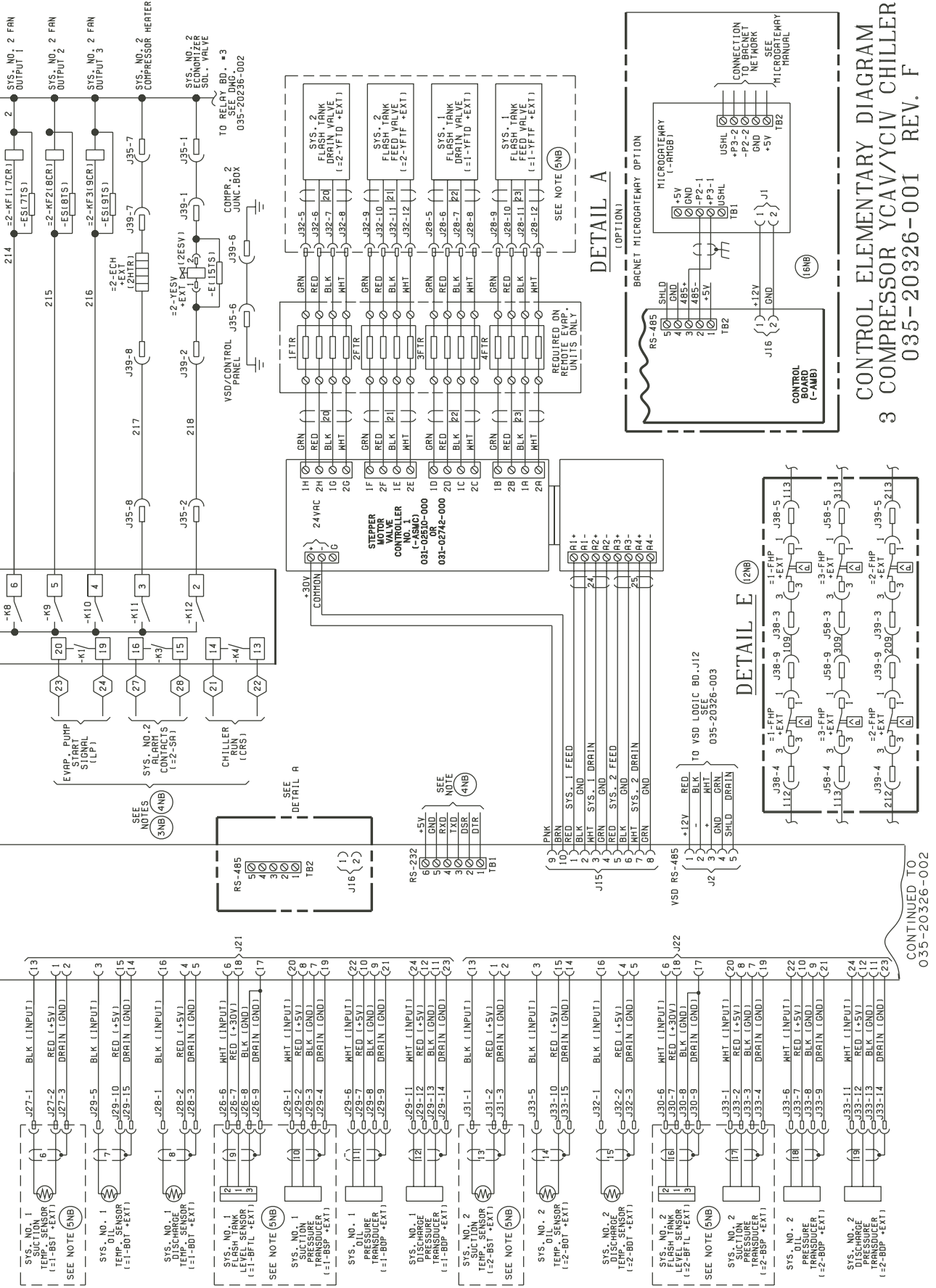

**CONTROL ELEMENTARY DIAGRAM  
3 COMPRESSOR YCAV/YCIV CHILLER  
035-20326-001 REV. F**

CONTINUED TO  
035-20326-002

For informational purposes only. Do not attempt to tie into wiring without a proper wiring diagram.

# Typical Control Wiring - Three Compressor - cont.

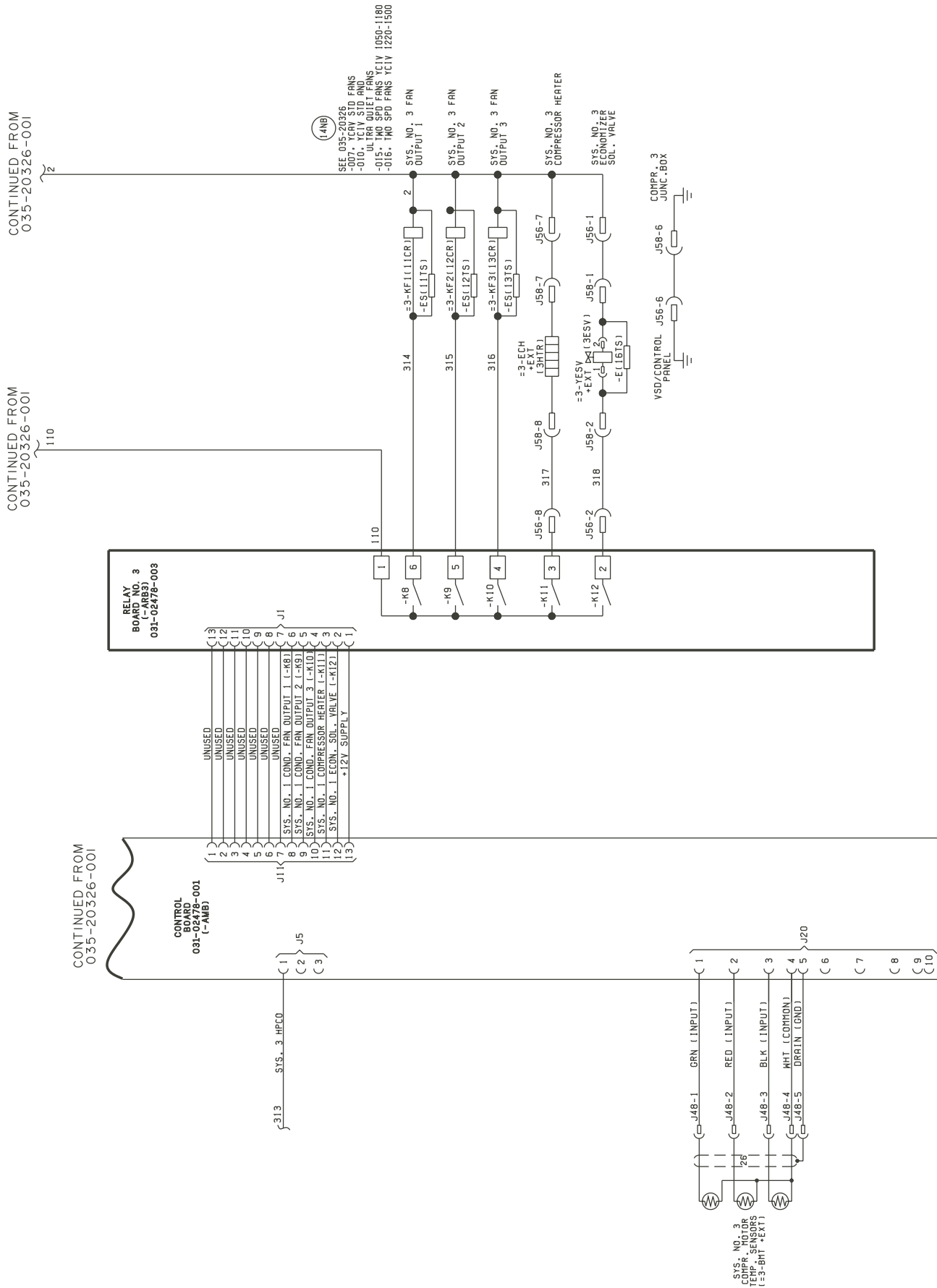

CONTROL ELEMENTARY DIAGRAM  
 3 COMPRESSOR YCAV/YCIV CHILLER  
 035-20326-002 REV. F

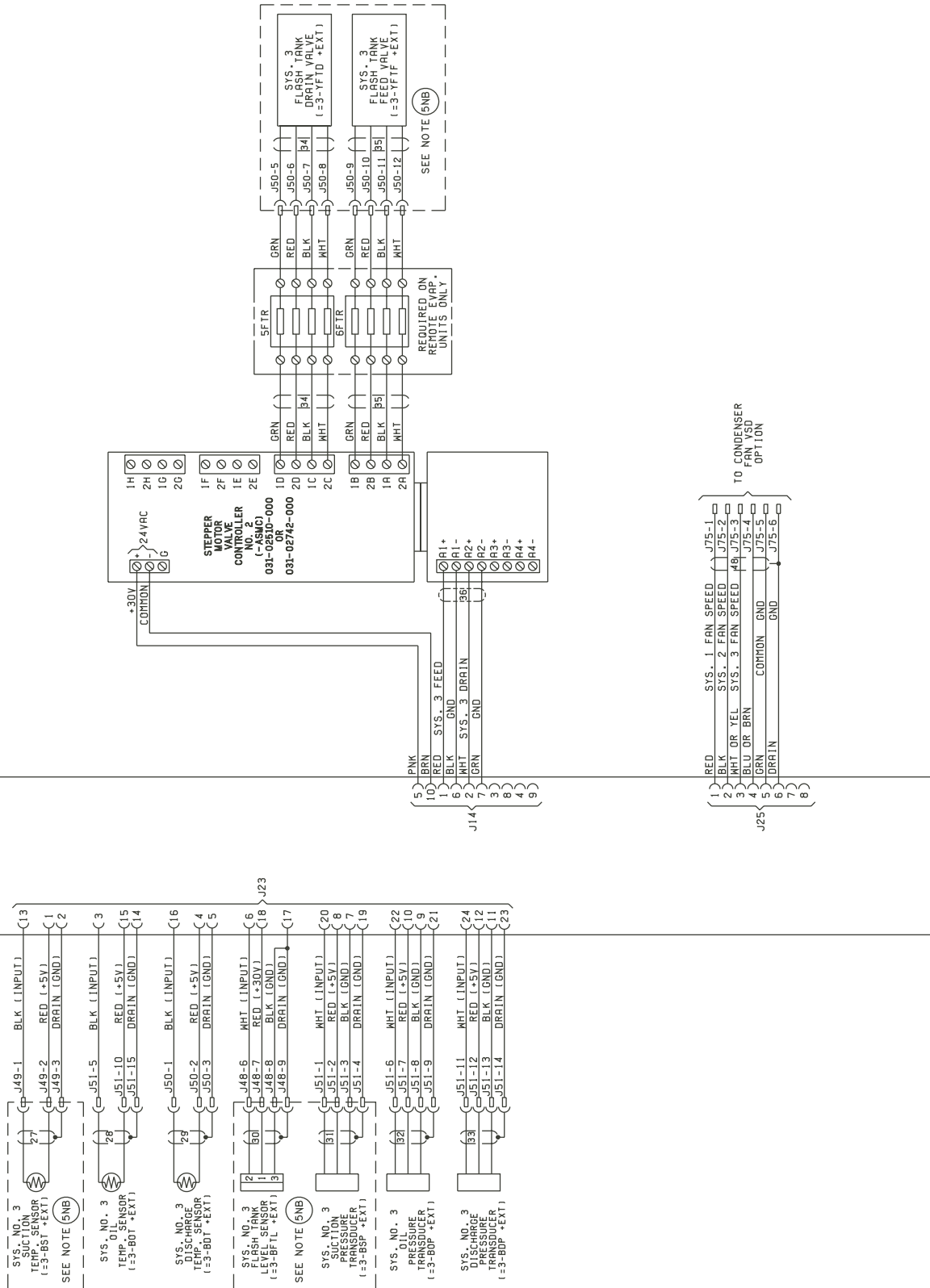

# Typical Control Wiring - Four Compressor

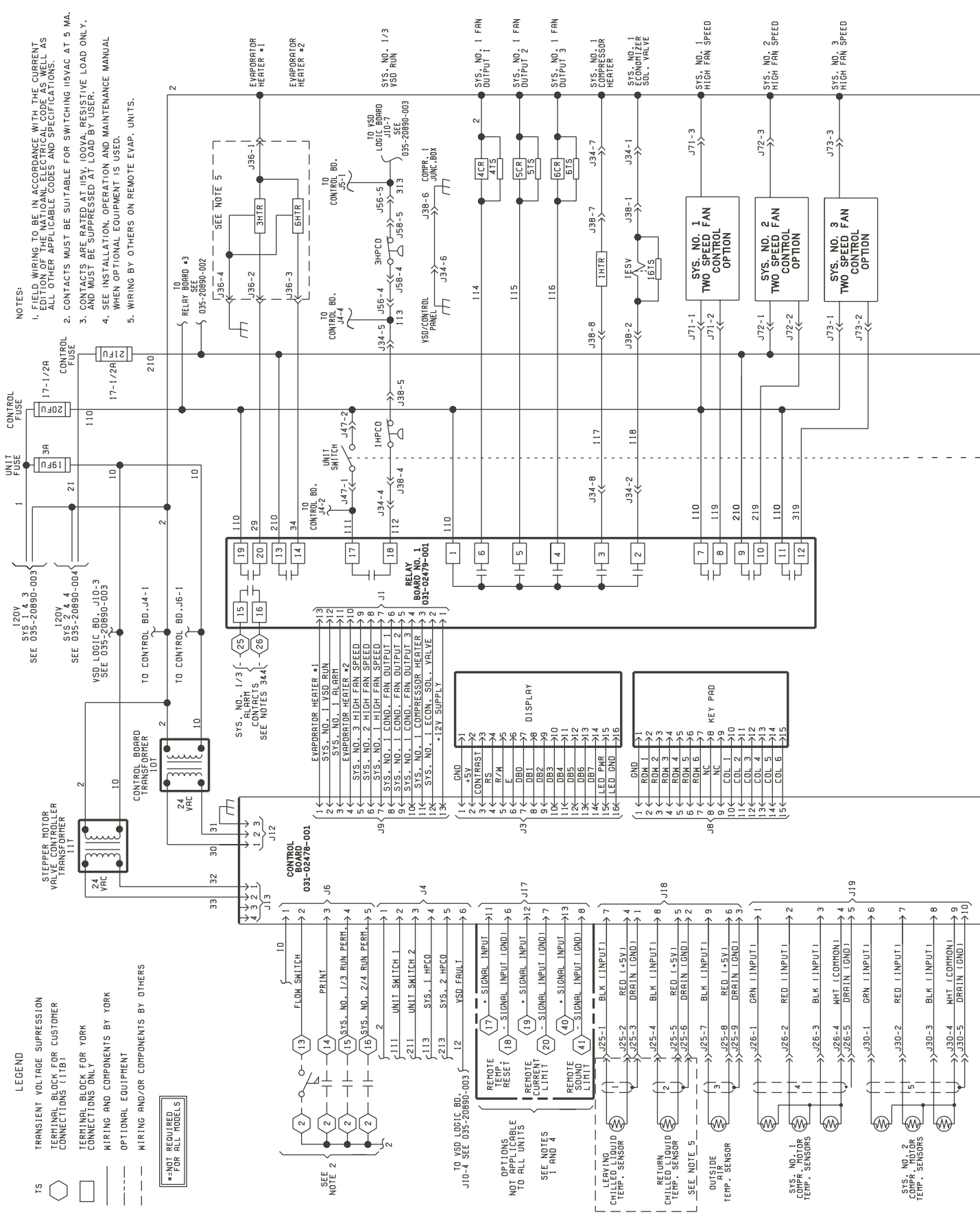

**NOTES:**

- FIELD WIRING TO BE IN ACCORDANCE WITH THE CURRENT EDITION OF THE NATIONAL ELECTRICAL CODE AS WELL AS ALL OTHER APPLICABLE CODES AND SPECIFICATIONS.
- CONTACTS MUST BE SUITABLE FOR SWITCHING IIRVAC AT 5 MA.
- CONTACTS ARE RATED AT 16V, 100VA, RESISTIVE LOAD ONLY, AND MUST BE SUPPRESSED AT LOAD BY USER.
- SEE INSTALLATION, OPERATION AND MAINTENANCE MANUAL WHEN OPTIONAL EQUIPMENT IS USED.
- WIRING BY OTHERS ON REMOTE EVAP. UNITS.

**LEGEND**

- IS TRANSIENT VOLTAGE SUPPRESSION TERMINAL BLOCK FOR CUSTOMER CONNECTIONS (ITB)
- TERMINAL BLOCK FOR YORK CONNECTIONS ONLY
- MIRING AND COMPONENTS BY YORK
- OPTIONAL EQUIPMENT
- MIRING AND/OR COMPONENTS BY OTHERS

\*NOT REQUIRED FOR ALL MODELS

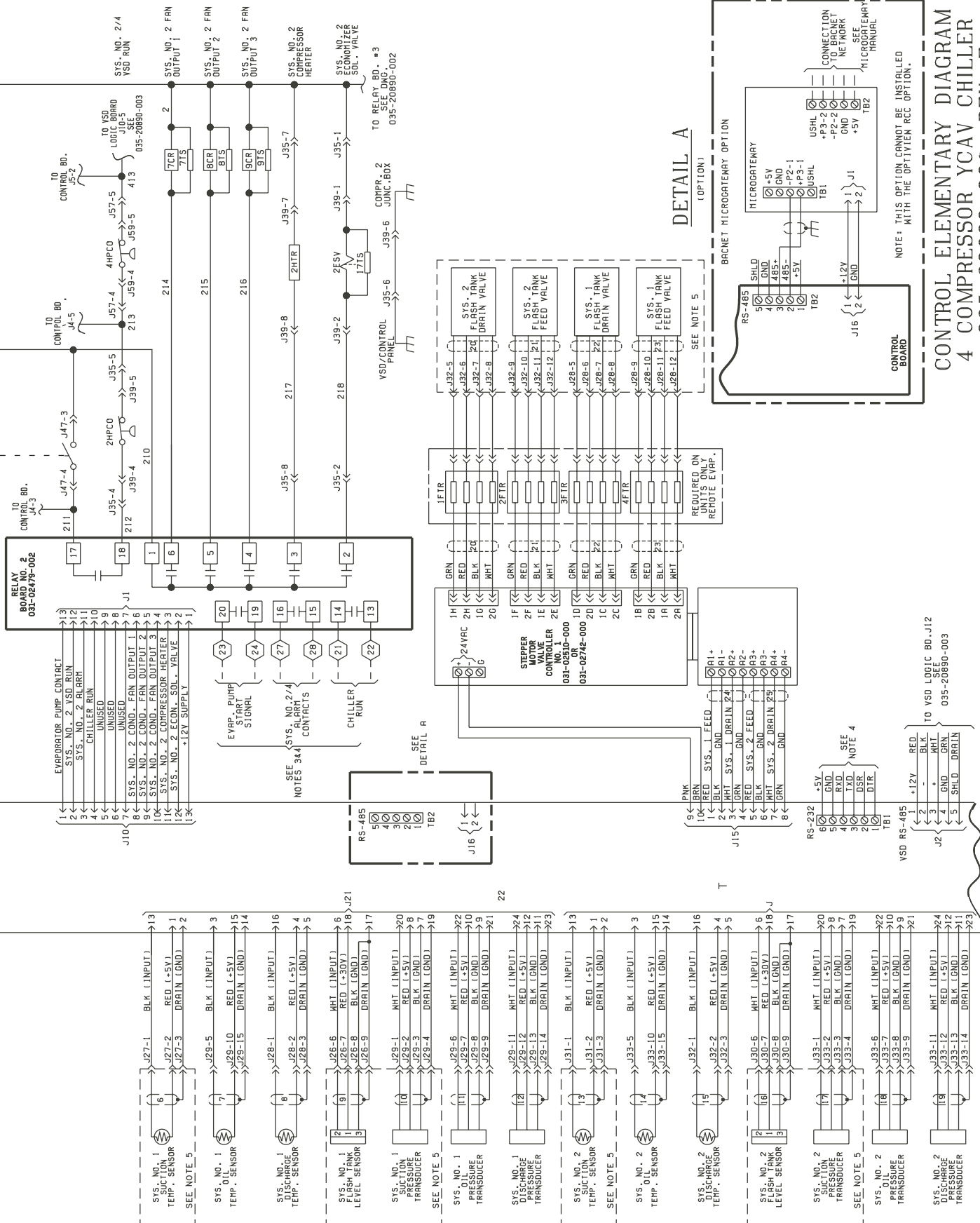

CONTINUED 0 035-20890-002

For informational purposes only. Do not attempt to tie into wiring without a proper wiring diagram.

# Typical Control Wiring - Four Compressor - cont.

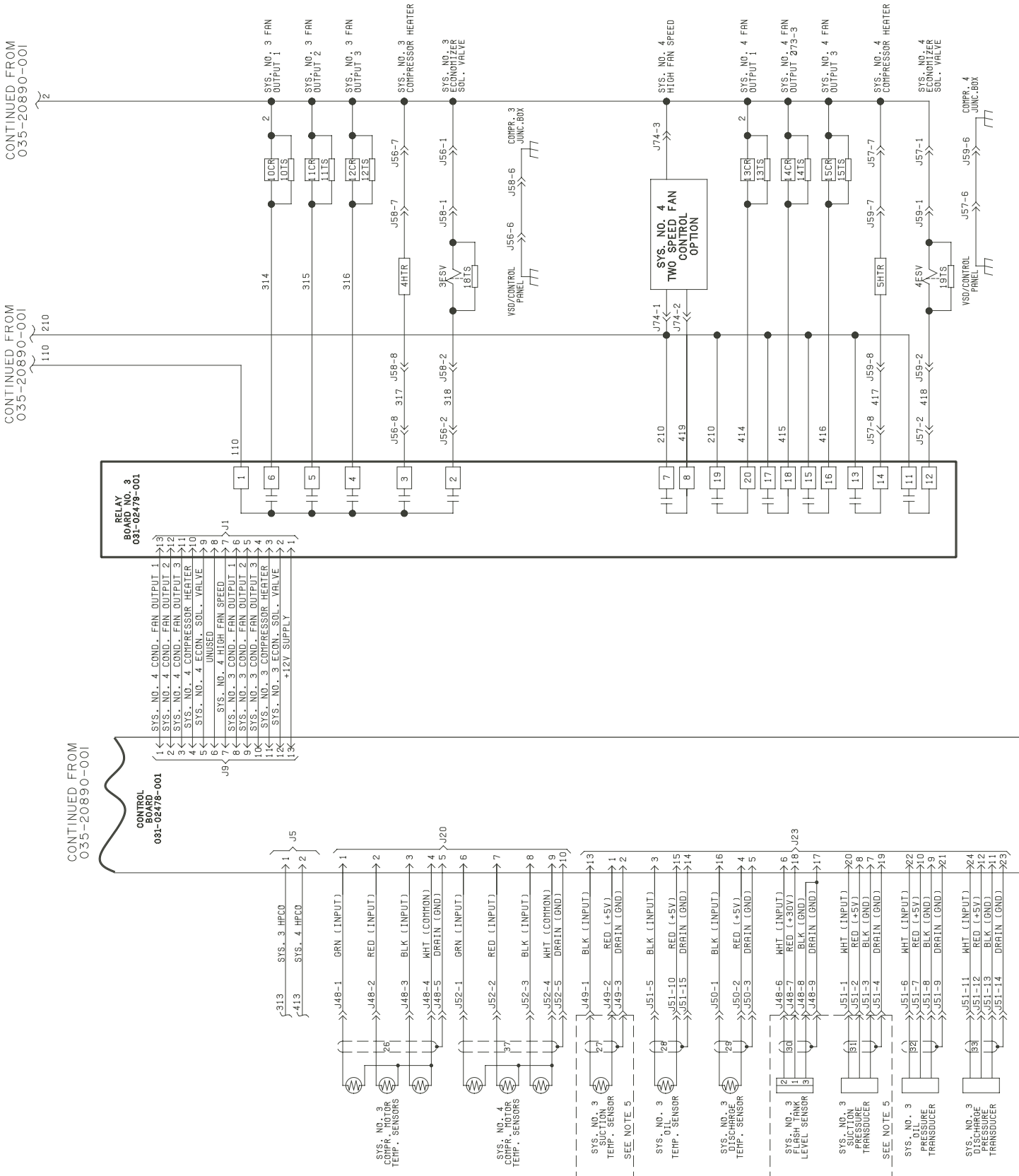

CONTROL ELEMENTARY DIAGRAM  
4 COMPRESSOR YCAV CHILLER  
035-20890-002 REV. E

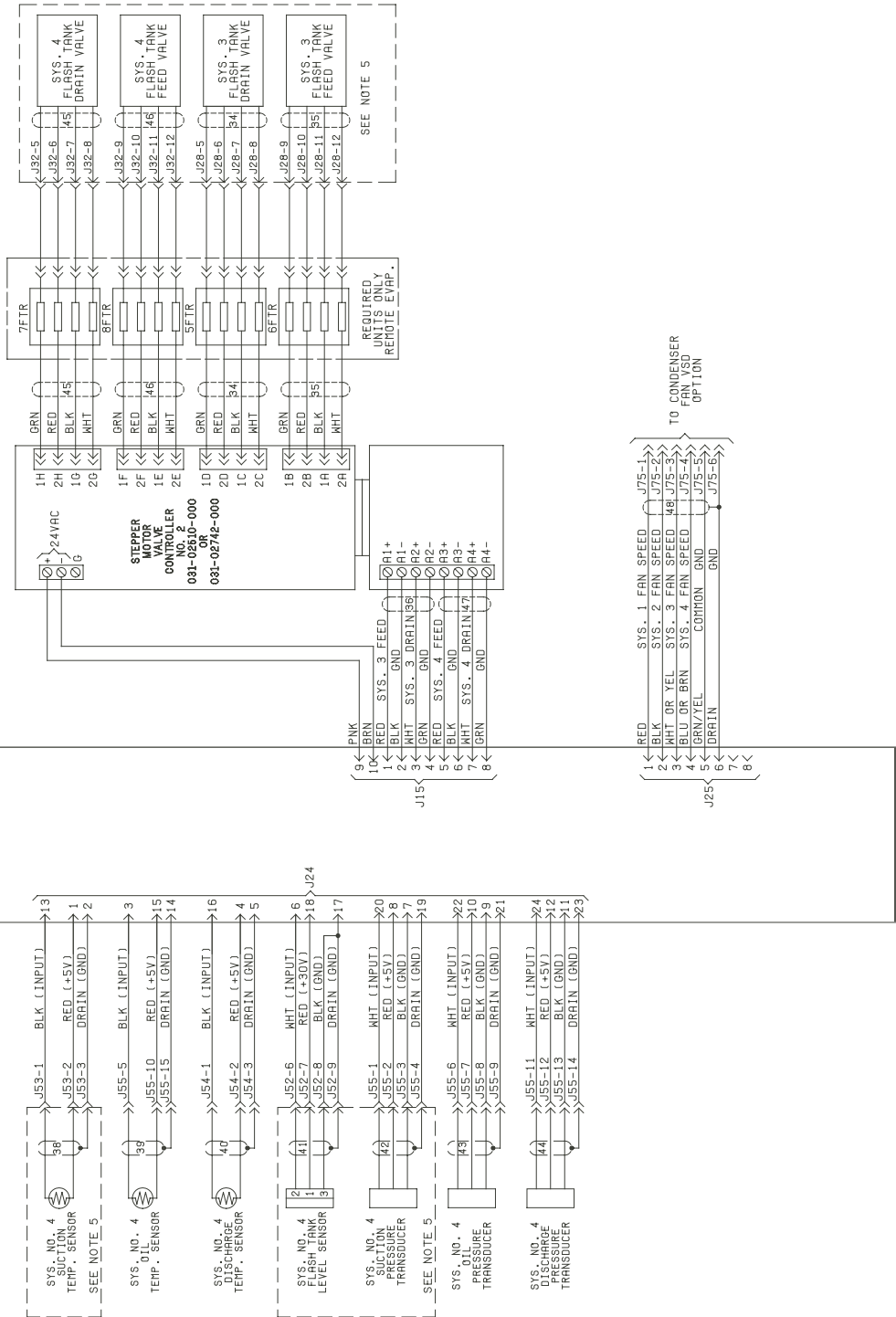

# Application Data

---

## UNIT LOCATION

The YCAV chillers are designed for outdoor installation. When selecting a site for installation, be guided by the following requirements:

1. Installation sites may be either on a roof or on ground level. (See FOUNDATION)
2. Select a place having an adequate supply of fresh air for the condensers. Recommended clearances for all units are shown on the DIMENSIONS pages.
3. Avoid locations near windows or structures where normal operating sounds may be objectionable.
4. The standard condenser fans are propeller-type and are not recommended for use with ductwork, filters or other impediments to airflow in the condenser air stream.
5. When it is desirable to surround the unit(s), it is recommended that the screening be able to pass the required chiller CFM without exceeding 0.1" external static pressure.
6. Protection against corrosive environments is available by supplying the units with either copper fins, or cured epoxy-coating on the condenser coils. Epoxy-coated coils should be utilized with any units being installed at the seashore, or where salt spray may hit the units, or where acid rain is prevalent (copper condenser coils are not recommended where they may be exposed to acid rain).
7. On installations where winter operation is intended and snow accumulations are expected, additional elevation must be provided to insure normal condenser air flow.

## FOUNDATION

The unit should be mounted on a flat and level foundation, ground or roof, capable of supporting the entire operating weight of the equipment. Operating weights are given in the PHYSICAL DATA tables.

**Roof Locations** – Adequate structural strength to safely support the entire weight of the unit and service personnel must be provided. Care must be taken not to damage the roof during installation. If the roof is “bonded”, consult building contractor or architect for special installation re-

quirements. Roof installations should incorporate the use of spring-type isolators to minimize the transmission of vibration into building structure. Additional support should be provided to the roof at the spring-isolator locations.

**Ground Locations** – Units must be installed on a substantial base that will not settle and cause strain on the refrigerant lines, resulting in possible leaks. A one-piece concrete slab, with footers extending below the frost line, is recommended. The slab should not be tied to the main building foundation as noises will telegraph.

Mounting holes (5/8") are provided in the base rails for bolting the unit to its foundation. See DIMENSIONS for location of the mounting holes.

For ground installations, precautions should be taken to protect the unit from tampering by, or injury to, unauthorized persons. Fasteners on access panels will prevent casual tampering; however, further safety precautions, such as unit enclosure options, a fenced-in enclosure, or locking devices on the panels may be advisable. Check local authorities for safety regulations.

## CHILLED LIQUID PIPING

The chilled liquid piping system should be laid out so that the circulating pump discharges into the cooler. The inlet and outlet cooler-liquid connections are given in DIMENSIONS. Hand stop valves are recommended for use in all lines to facilitate servicing. Drain connections should be provided at all low points to permit complete drainage of the cooler and system piping.

A strainer (40 mesh) is recommended for use on the INLET line to the cooler, and must be in place at initial operation of the water pumps.

Pressure-gauge connections are recommended for installation in the inlet and outlet water lines. Gauges are not provided with the unit and are to be furnished by others.

Chilled liquid lines exposed to the weather should be wrapped with a supplemental heater cable and insulated, or glycol should be added to the chilled liquid to protect against freezing if low-ambient periods are expected.

A flow switch is available as an accessory on all units. A flow switch must be installed in the leaving water piping of the cooler and must not be used to start and stop the unit.



# Guide Specifications

## PART 1 — GENERAL

### 1.01 SCOPE

- A. The requirements of the General Conditions, Supplementary Conditions, Division 1, and Drawings apply to all work herein.
- B. Provide Microprocessor controlled, twin-screw compressor, air-cooled, liquid chillers of the scheduled capacities as shown and indicated on the Drawings, including but not limited to:
  1. Chiller package
  2. Charge of refrigerant (Except remote evaporator applications) and oil.
  3. Electrical power and control connections
  4. Chilled water connections
  5. Factory start-up

### 1.02 QUALITY ASSURANCE

- A. Products shall be Designed, Tested, Rated and Certified in accordance with, and installed in compliance with applicable sections of the following Standards and Codes:
  1. ARI 550/590 – Water Chilling Packages Using the Vapor Compression Cycle
  2. ARI 370 – Sound Rating of Large Outdoor Refrigerating and Air Conditioning Equipment
  3. ANSI/ASHRAE Standard 15 – Safety Code for Mechanical Refrigeration
  4. ASHRAE 34 – Number Designation and Safety Classification of Refrigerants
  5. ASHRAE 90.1 – Energy Standard for Buildings Except Low-Rise Residential Buildings
  6. ANSI/NFPA Standard 70 – National Electrical Code (N.E.C).
  7. ASME Boiler and Pressure Vessel Code, Section VIII, Division 1.
  8. ASTM A48 – Gray Iron Castings
  9. OSHA – Occupational Safety and Health Act
  10. Manufactured in facility registered to ISO 9002
  11. Conform to Underwriters Laboratories (U.L.) for construction of chillers and provide U.L./cU.L. listing label.
- B. Factory Test: Chiller shall be pressure-tested, evacuated and fully charged with refrigerant and oil, and shall be factory operational run tested with water flowing through the vessel.

- C. Chiller manufacturer shall have a factory trained and supported service organization that is within a 50 mile (80 km) radius of the site.
- D. Warranty: Manufacturer shall Warrant all equipment and material of its manufacture against defects in workmanship and material for a period of eighteen (18) months from date of initial start-up or date of shipment, whichever occurs first.

### 1.03 DELIVERY AND HANDLING

- A. Unit shall be delivered to job site fully assembled and charged with refrigerant (except remote evaporator applications) and oil by the Manufacturer.
- B. During shipment, provide protective covering over vulnerable components. Fit nozzles and open ends with plastic enclosures.
- C. Protect the chiller and its accessories from the weather and dirt exposure during shipment.
- D. Unit shall be stored and handled per Manufacturer's instructions.

## PART 2 — PRODUCTS

### 2.01 GENERAL

- A. Manufacturers: The design shown on the drawings is based on Johnson Controls. Alternate equipment will be acceptable if their equipment meets the scheduled performance and complies with these specifications. If equipment manufactured by a manufacturer other than that scheduled is utilized, then the Mechanical Contractor shall be responsible for coordinating with the General Contractor and all affected Subcontractors to insure proper provisions for installation of the furnished unit. This coordination shall include, but not be limited to, the following:
  1. Structural supports for units.
  2. Piping size and connection/header locations.
  3. Electrical power requirements and wire/conduit and overcurrent protection sizes.

The Mechanical Contractor shall be responsible for all costs incurred by the General Contractor, Subcontractors, and Consultants to modify the building provisions to accept the furnished units.

- B. Description: Install and commission, as shown on the schedules and plans, factory assembled, charged,

# Guide Specifications - continued

and operational tested air-cooled screw compressor chiller(s) as specified herein. Chiller shall include, but is not limited to: a complete system with multiple independent refrigerant circuits, semi-hermetic twin screw compressors, shell and tube type evaporator, air-cooled condenser, R134a refrigerant, lubrication system, interconnecting wiring, safety and operating controls including capacity controller, control center, motor starting components, and special features as specified herein or required for safe, automatic operation.

## C. Operating Characteristics:

1. Provide low ambient control and high ambient options as required to ensure unit is capable of operation from 0°F to 125°F (-18°C to 52°C) ambient.
2. Provide capacity control system capable of reducing unit capacity to (10% for 2 compressor units, 7.5% for 3 compressor units, and 5% for four compressor units) of full load. Compressor shall start in unloaded condition. Application of factory installed hot gas bypass shall be acceptable as required to meet specified minimum load.

D. Cabinet: Unit panels, structural elements, control boxes and heavy gauge structural base shall be constructed of galvanized steel. Unit panels, control boxes and structural base are finished with a baked on powder paint. All painted surfaces shall be coated with baked on powder paint which, when subject to ASTM B117, 1,000 hour, 5% salt spray test, yields minimum ASTM 1654 rating of "6".

E. Unit shall ship in one piece and shall require installer to provide only a single evaporator inlet and outlet pipe connection. If providing chiller model that ships in multiple pieces, bid shall include all the material and field labor costs for factory authorized personnel to install a trim kit to connect the pieces as well as all interconnecting piping and wiring.

## 2.02 COMPRESSORS AND MOTORS

A. Compressors: Shall be direct drive, semi-hermetic, rotary twin-screw type, including: muffler, temperature actuated 'off-cycle' heater, rain-tight terminal box, discharge shut-off service valve, and precision machined cast iron housing mounted on elastomeric isolators. Design working pressure of entire compressor, suction to discharge, shall be 380 psig (26 barg) or higher. Compressor shall be U.L. Recognized.

B. Motors: Refrigerant suction gas cooled accessible hermetic compressor motor, full suction gas flow

through 0.006" maximum mesh screen, with inherent internal thermal overload protection and external current overload on all three phases.

C. Lubrication: External oil separators with no moving parts, 450 psig design working pressure, and UL listing. Refrigerant system differential pressure shall provide oil flow through service replaceable, 0.5 micron, full flow, cartridge type oil filter internal to compressor. Filter bypass, less restrictive media, or oil pump not acceptable.

D. Capacity Control: Compressors shall start at minimum load. Provide Microprocessor control to command compressor capacity to balance compressor capacity with cooling load. When required to meet minimum load, hot gas bypass shall be factory installed and integrated into standard control system.

## 2.03 REFRIGERANT CIRCUIT COMPONENTS

A. Each independent refrigerant circuit shall include: liquid line shutoff valve with charging port, low side pressure relief device, removable core filter-drier, sight glass with moisture indicator, and electronic expansion valve.

B. Chiller manufacturer shall provide independent circuit for each compressor to provide maximum redundancy. If equipment does not have independent circuits per compressor, manufacturer shall provide owner one spare compressor of each unique size.

C. Discharge lines shall be provided with manual compressor shutoff service valves. Acoustical wrap shall be included on the discharge line and oil separators. Suction line shall be covered with closed cell foam insulation.

## 2.04 HEAT EXCHANGERS

A. Evaporator:

1. Direct expansion type or flooded type shell and tube evaporator with high efficiency copper tubes. Independent refrigerant circuits shall be provided per compressor.

2. Constructed, tested, and stamped in accordance with applicable sections of ASME pressure vessel code for minimum 235 psig (16 barg) refrigerant side design working pressure and 150 psig (10 barg) water side design working pressure.

3. Shell covered with 3/4" (19mm), flexible, closed-cell insulation, thermal conductivity of 0.26k maximum. Water nozzles with grooves for mechanical couplings, and insulated by Contractor after pipe installation.

4. Provide vent and drain fittings, and thermostatically controlled heaters to protect to -20°F (-29°C) ambient in off-cycle.

**B. Air-cooled Condenser:**

1. Coils: Internally enhanced, seamless copper tubes, mechanically expanded into aluminum alloy fins with full height collars. Subcooling coil an integral part of condenser. Design working pressure shall be 450 psig (31 barg).
2. Low Sound Fans: Shall be dynamically and statically balanced, direct drive, corrosion resistant glass fiber reinforced composite blades molded into low noise, full airfoil cross section, providing vertical air discharge from extended orifices. Guards of heavy gauge, PVC (polyvinyl chloride) coated or galvanized steel.
3. Fan Motors: High efficiency, direct drive, 3-phase, insulation class "F", current protected, Totally Enclosed Air Over (TEAO), with double sealed, permanently lubricated ball bearings.

**2.05 POWER AND ELECTRICAL REQUIREMENTS**

**A. Power/Control Panel:**

1. NEMA 3R (IP55), powder painted steel cabinets with hinged, latched, and gasket sealed outer doors equipped with wind struts for safer servicing. Provide main power connection(s), compressor starters and fan motor contactors, current overloads, and factory wiring.
2. Panel shall include control display access door.

**B. Single Point Power (As standard for 2 and 3 compressor, available option for 4 compressor)**

1. Provide single point power connection to chiller, shall be 3 phase of scheduled voltage.
2. Circuit breaker shall be provided at point of incoming single point connection to provide disconnecting means AND be sized to provide the motor branch circuit protection, short circuit protection and ground fault protection for the motor branch-circuit conductors, the motor control apparatus and the motors. Circuit breaker shall be equipped with lockable operating handle that shall extend through power panel door so that power may be disconnected without opening any panel doors.

**And/OR**

**B. Multi Point Power (Standard for 4-compressor Units)**

1. Provide multi point power connections to chiller, shall be 3 phase of scheduled voltage (for 4-compressor units).
2. Circuit breakers shall be provided at each point of field power connection. Circuit breakers shall be equipped with lockable handles. The circuit breakers shall be sized to provide the motor branch circuit protection, short circuit protection and ground fault protection for the motor branch-circuit conductors, the motor control apparatus and the motors. The circuit breaker rating shall be in accordance with UL508C. Factory wiring shall be provided from multiple circuit breakers to the system components. Refer to schedule for size and number of power connections. All power connections shall be located in one area of the chiller. If equipment supplied requires power connections in more than one area of the chiller; mechanical contractor is responsible for cost and coordination of any changes to electrical or structural designs.

**C. Control Transformer: Power panel shall be supplied with a factory mounted and wired control transformer that will supply all unit control voltage from the main unit power supply. Transformer shall utilize scheduled line voltage on the primary side and provide 115V/1Ø on secondary.**

**D. Short Circuit Withstand Rating of the chiller electrical enclosure shall be (200V & 230V: 100,000 Amps, 380 & 460V: 65,000 Amps, 575V: 42,000 Amps). Rating shall be in accordance with UL508.**

**E. Motor Starters: Motors starters shall be reduced inrush type (Wye-Delta or Solid State) for minimum electrical inrush. Across the line type starters will not be acceptable.**

**F. Power Factor:**

1. Provide equipment with power factor correction capacitors as required to maintain a displacement power factor of 95% at all load conditions.
2. The installing contractor is responsible for additional cost to furnish and install power factor correction capacitors if they are not factory mounted and wired.

**G. Exposed compressor and fan motor power wiring shall be routed through liquid tight conduit.**

# Guide Specifications - continued

## 2.06 CONTROLS

### A. General:

1. Provide automatic control of chiller operation including compressor start/stop and load/unload, anti-recycle timers, condenser fans, evaporator pump, evaporator heater, unit alarm contacts and run signal contacts.
2. Chiller shall automatically reset to normal chiller operation after power failure.
3. Unit operating software shall be stored in non-volatile memory. Field programmed set points shall be retained in lithium battery backed real time clock (RTC) memory for minimum 5 years.
4. Alarm contacts shall be provided to remote alert for any unit or system safety fault.

### B. Display and Keypad:

1. Provide minimum 80 character liquid crystal display that is both viewable in direct sunlight and has LED backlighting for nighttime viewing. Provide one keypad and display panel per chiller. The display is rated for 200 nits.
2. Display and keypad shall be accessible through display access door without opening main control/electrical cabinet doors.
3. Display shall provide a minimum of unit setpoints, status, electrical data, temperature data, pressures, safety lockouts and diagnostics without the use of a coded display.
4. Descriptions in English (or Spanish or French), numeric data in English (or Metric) units.
5. Sealed keypad shall include unit On/Off switch.

C. Programmable Setpoints (within Manufacturer limits): display language; leaving chilled liquid temperature: setpoint, control range; local or remote control; units of measure; compressor lead/lag; and maximum chilled water setpoint reset temperature range.

D. Display Data: Chiller liquid return and leaving temperatures, ambient, lead compressor identification, clock and schedule, (variable) out of range, remote input indication, chilled liquid reset setpoint, and history data for last ten shutdown faults. Compressor suction, discharge, and oil pressures and temperatures, suction and discharge superheats, operating hours, starts, and anti-recycle timer status. Status Messages for manual override, unit switch off, compressor run, run

permissive, remote controlled shut down, no cooling load, daily/holiday shut down, anti-recycle timer.

E. Predictive Control Points: Unit controls shall avoid safety shutdown when operating outside design conditions by optimizing the chiller controls and cooling load output to stay online and avoid safety limits being reached. The system shall monitor the following parameters and maintain the maximum cooling output possible without shutdown of the equipment: motor current, suction pressure and discharge pressure.

F. System Safeties: Shall cause individual compressor systems to perform auto-reset shut down; manual reset required after the third trip in 90 minutes. Includes: high discharge pressure or temperature, low suction pressure, high / low motor current, high motor temperature, high pressure switch, high / low differential oil pressure, high oil temperature, low suction superheat, critical sensor malfunction, low or high current, phase loss/single phase power, overload of motor windings, and low voltage.

G. Unit Safeties: Shall be automatic reset and cause compressors to shut down if: high or low ambient, low leaving chilled liquid temperature, under voltage, and flow switch operation. Contractor shall provide flow switch and wiring per chiller manufacturer requirements.

H. Manufacturer shall provide any controls not listed above, necessary for automatic chiller operation. Mechanical Contractor shall provide field control wiring necessary to interface sensors to the chiller control system.

## 2.07 ACCESSORIES AND OPTIONS

Some accessories and options supersede standard product features. Your Johnson Controls representative will be pleased to provide assistance.

### A. Sound Reduction

1. Provide the following options as required to meet scheduled sound performance data at all load points.
  - a. Ultra Quiet fans (**Factory Mounted**)
  - b. Compressor Sound Blankets (**Factory Mounted**)
  - c. Acoustical perimeter enclosures (**Field Mounted**)



Sound Power Levels									
Chiller Load	Octave Band Center Frequency, Hz								A- Weighted (dBA)
	63	125	250	500	1000	2000	4000	8000	
100%									
75%									
50%									
25%									

Sound power octave band data, dB per ARI standard 370.

- Provide optional control input to limit sound output of the chiller based on time of day. Shall be programmable at the chiller panel or controlled remotely via signal (4-20mA or 0-10 VDC) from BAS system. Chillers without this feature shall be provided with the necessary sound attenuation to meet the scheduled sound performance data at all load points.

#### B. Power Supply/Connections:

- Terminal Block Power Connection:** Power connections shall be made to a Terminal Block with factory provided interconnecting wiring to chiller components.

#### C. Condenser Coil Environmental Protection:

- PRE-COATED FIN CONDENSER COILS –**  
The air-cooled condenser coils are constructed of epoxy-coated aluminum fins.
- COPPER FIN –** Provide condenser coils with copper fins in lieu of aluminum fins.
- POST-COATED EPOXY DIPPED CONDENSER COILS –** The unit is built with dipped-cured condenser coils.

#### D. Protective Chiller Panels (**Factory Mounted**):

- Louvered Panels (condenser coils only):** Painted steel to match unit panels, over external condenser coil faces.
- Wire Panels (full unit):** Heavy gauge, welded wire mesh, coated to resist corrosion, to protect condenser coils from incidental damage and restrict unauthorized access to internal components.
- Louvered Panels (full unit):** Painted steel to match unit panels, to protect condenser coils from incidental damage, visually screen internal components, and prevent unauthorized access to internal components.

- Louvered/Wire Panels:** Louvered steel panels on external condenser coil faces, painted to match unit panels. Heavy gauge, welded wire-mesh, coated to resist corrosion, around base of machine to restrict unauthorized access.

#### E. Evaporator options:

- Provide 1-1/2" cooler insulation in lieu of standard 3/4".
- Provide DX Cooler with 300 psig (20.7 barg) waterside design working pressure in lieu of standard 150 psig (10.3 barg).
- Provide Raised Face Flanges for cooler nozzles:
  - 150 psig (10.3 barg), welded flanges (field kit, matching pipe flange by contractor).
  - 300 psig (20.7 barg), welded flanges (factory installed, matching pipe flange by contractor).
  - 150 psig (10.3 barg), Victaulic™ Flanges (field kit, matching pipe flange by contractor).

- F. **Flow Switch (Field Mounted):** Vapor proof SPDT, NEMA 3R switch [\_\_\_ 150 psig (10.3 barg) or \_\_\_ 300 psig (20.7 barg)], -20°F to 250°F (-28.9°C to 121.1°C).

#### G. Building Automation System Interface:

- Chiller to accept 4 to 20mA or 0 to 10 VDC input to reset the leaving chilled liquid temperature. (**Factory Mounted**)
- Provide chiller with microgateway for an interface to other systems that can share data via BACNet™, the ASHRAE open systems protocol. (**Factory Mounted**)

- H. **Multi-Unit Sequence Control (Field Mounted):** Separate Sequencing control center provided to permit control of up to eight chillers in parallel based on mixed liquid temperature.

#### I. Vibration Isolation (**Field Mounted**):

- Elastomeric Isolators.
- 1 Inch Deflection Spring Isolators: Level adjustable, spring and cage type isolators for mounting under the unit base rails.
- 2 Inch Deflection Seismic Isolators: Level adjustable, restrained mounts in rugged welded steel housing with vertical and horizontal limit stops. Housings shall be designed to withstand a minimum 1.0g accelerated force in all directions to 2" (50.8 mm).

# Guide Specifications - continued

J. Provide suction service shut-off valve for each compressor. (**Factory Mounted**)

## PART 3 — EXECUTION

### 3.01 INSTALLATION

A. General: Rig and Install in full accordance with Manufacturer's requirements, Project drawings, and Contract documents.

B. Location: Locate chiller as indicated on drawings, including cleaning and service maintenance clearance per Manufacturer instructions. Adjust and level chiller on support structure.

C. Components: Installing Contractor shall provide and install all auxiliary devices and accessories for fully operational chiller.

D. Electrical: Coordinate electrical requirements and connections for all power feeds with Electrical Contractor (Division 16).

E. Controls: Coordinate all control requirements and connections with Controls Contractor.

F. Finish: Installing Contractor shall paint damaged and abraded factory finish with touch-up paint matching factory finish.