



BY JOHNSON CONTROLS



***Model YCAL Air-Cooled Scroll Compressor Liquid Chillers
Style E***

50 and 60Hz
15 – 65 TON
53 – 218 kW
R-410A



Table of Contents

FORM 150.67-EG1 (713)	1
Introduction.....	3
Specification	4
MicroComputer Control Center.....	5
Options and Accessories	7
Unit Nomenclature.....	10
Selection Data.....	11
Selection Data - cont.....	12
Design Parameters.....	13
Water Pressure Drop.....	14
Ratings - R-410A (60Hz - English Units).....	16
Ratings - R-410A (60Hz - SI Units)	22
Ratings - R-410A (50Hz - English Units).....	26
Ratings - R-410A (50Hz - SI Units)	32
Part Load Ratings - 60 Hz R-410A (English Units)	36
Part Load Ratings - 50 Hz R-410A (English Units)	37
Physical Data - English & SI.....	38
Dimensions - YCAL0019 (English).....	40
Dimensions - YCAL0022 (English).....	42
Dimensions - YCAL0028 (English).....	44
Dimensions - YCAL0033 (English).....	46
Dimensions - YCAL0043 (English).....	48
Dimensions - YCAL0046 (English).....	50
Dimensions - YCAL0052 (English).....	52
Dimensions - YCAL0056 (English).....	54
Dimensions - YCAL0066 (English).....	56
Dimensions - YCAL0019 (SI)	58
Dimensions - YCAL0022 (SI)	60
Dimensions - YCAL0028 (SI)	62
Dimensions - YCAL0033 (SI)	64
Dimensions - YCAL0043 (SI)	66
Dimensions - YCAL0046 (SI)	68
Dimensions - YCAL0052 (SI)	70
Dimensions - YCAL0056 (SI)	72
Dimensions - YCAL0066 (SI)	74
Isolator Selections.....	76
Electrical Data - 50 & 60Hz.....	80
Electrical Notes.....	82
Circuit Breaker Calculations	84
Power Wiring - Single Circuit	85
Power Wiring - Dual Circuit	89
Control Wiring.....	93
Application Data	94
Guide Specifications	96

PERFORMANCE DATA PROVIDED IN THIS DOCUMENT WAS CREATED IN ACCORDANCE WITH JOHNSON CONTROLS SOFTWARE: YORKWORKS VERSION 13.02 AND DXCHILL VERSION 6.04



Introduction

Model YCAL Air-Cooled Scroll Compressor Liquid Chillers Style E



YORK Air-Cooled Scroll Chillers provide chilled water for all air conditioning applications using central station air handling or terminal units. They are completely self-contained and are designed for outdoor (roof or ground level) installation. Each unit includes hermetic scroll compressors, a liquid cooler, air cooled condenser, a charge of refrigerant R-410A, and a weather resistant microprocessor control center, all mounted on a rugged, formed-steel base.

Specification

GENERAL

The 15 - 65 Ton (53 - 218 kW) YCAL models are shipped complete from the factory ready for installation and use.

The unit is pressure-tested, evacuated, and fully charged with Refrigerant-410A and includes an initial oil charge. After assembly, a complete operational test is performed with water flowing through the cooler to assure that the refrigeration circuit operates correctly.

The unit structure is heavy-gauge, galvanized steel. The steel is coated with baked-on powder paint, which, when subjected to ASTM B117 1000 hour, salt spray testing, yields a minimum ASTM 1654 rating of "6". Corrosion resistant wire mesh panels are added to protect the condenser coil from incidental damage and restrict unauthorized access to internal components. Unit also includes service isolation valves as standard. **Units are designed in accordance with NFPA 70 (National Electric Code), ASHRAE/ANSI 15 Safety code for mechanical refrigeration, ASME, Listed and labeled with Intertek Testing Services (ETL) and rated in accordance with the latest version of ARI Standard 550/590.**

COMPRESSORS

The chiller has suction-gas cooled, hermetic, scroll compressors. The compressors incorporate a scroll design that is compliant in both the axial and radial direction. All rotating parts are statically and dynamically balanced. A large internal volume and oil reservoir provides greater liquid tolerance. Compressor crankcase heaters are also included for extra protection against liquid migration.

COOLER

Brazed plate heat exchangers are UL (Underwriters Laboratories) listed. Installing contractor must include ac-

commodations in the chilled water piping to allow proper drainage and venting of the heat exchanger. Water inlet and outlet connections are grooved for compatibility with factory supplied ANSI/AWWA C-606 connections.

The cooler is equipped with a heater controlled by a separate thermostat. The heater provides freeze protection for the cooler down to -20°F (-29°C) ambient. The cooler is covered with 3/4" (19mm) flexible, closed-cell, foam insulation (K≈0.25).

A 40 mesh strainer (0.5 and 1.5 mm) is recommended upstream of the heat exchanger to prevent clogging.

CONDENSER

Coils – Fin and tube condenser coils of seamless, internally-enhanced, high-condensing-coefficient, corrosion resistant copper tubes are arranged in staggered rows, mechanically expanded into aluminum fins. Integral subcooling is included. The design working pressure of the coil is 650 PSIG (45 barg).

Low Sound Fans – The condenser fans are composed of corrosion resistant aluminum hub and composite blades molded into a low noise airfoil section. They are designed for maximum efficiency and are statically and dynamically balanced for vibration-free operation. They are directly driven, and positioned for vertical air discharge. The fan guards are constructed of heavy-gauge, rust-resistant, PVC (polyvinyl chloride)-coated steel wire.

Motors – The fan motors are Totally Enclosed Air-Over, squirrel-cage type, current protected. They feature ball bearings that are double-sealed and permanently lubricated.

MicroComputer Control Center

All controls are contained in a NEMA 3R powder painted steel cabinet with a gasketed door and include:

Liquid Crystal Display (LCD) with Light Emitting Diode (LED) backlighting for outdoor viewing:

Two display lines

Twenty characters per line

Color coded 12-button non-tactile keypad with sections for:

DISPLAY/PRINT of typical information:

Chilled liquid temperatures

Ambient temperature

System pressures (each circuit)

Operating hours and starts (each compressor)

Print calls up to the liquid crystal display:

Operating data for the systems

History of fault shutdown data for up to the last six fault shutdown conditions

An RS-232 port, in conjunction with this press-to-print button, is provided to permit the capability of hard copy print-outs via a separate printer (by others).

ENTRY section to:

ENTER setpoints or modify system values

SETPOINTS updating can be performed to:

Chilled liquid temperature setpoint and range

Remote reset temperature range

Set daily schedule/holiday for start/stop

Manual override for servicing

Low and high ambient cutouts

Number of compressors

Low liquid temperature cutout

Low suction pressure cutout

High discharge pressure cutout

Anti-recycle timer (compressor start cycle time)

Anti-coincident timer (delay compressor starts)

UNIT section to:

Set time

Set unit options

UNIT ON/OFF switch

The microprocessor control center is capable of displaying the following:

- Return and leaving liquid temperature
- Low leaving liquid temperature cutout setting
- Low ambient temperature cutout setting
- Outdoor air temperature
- English or Metric data
- Suction pressure cutout setting
- Each system suction pressure
- Discharge pressure (optional)
- Liquid Temperature Reset via a Johnson Controls ISN DDC or Building Automation System (by others) via:
 - a pulse width modulated (PWM) input as standard
 - a 4-20 milliamp or 0 -10 VDC input, or contact closure with the optional B.A.S. interface option
- Anti-recycle timer status for each system
- Anti-coincident system start timer condition
- Compressor run status
- No cooling load condition
- Day, date and time
- Daily start/stop times
- Holiday status
- Automatic or manual system lead/lag control
- Lead system definition
- Compressor starts & operating hours (each compressor)
- Status of hot gas valves, evaporator heater and fan operation
- Run permissive status
- Number of compressors running
- Liquid solenoid valve status
- Load & unload timer status
- Water pump status

* Intensity of Protection European Standard

MicroComputer Control Center - continued

The panel has provisions for: pumpdown at shutdown; optional remote chilled water temperature reset and two steps of demand load limiting from an external building automation system. Unit alarm contacts are standard.

The operating program is stored in non-volatile memory (EPROM) to eliminate chiller failure due to AC powered failure/battery discharge. Programmed setpoints are retained in lithium battery-backed RTC memory for 5 years minimum.

COMMUNICATIONS

- Native communication capability for BACnet (MS/TP), Modbus and N2
- Optional communication available for LON via eLink option

POWER PANEL

Each panel contains:

- Compressor power terminals
- Compressor motor starting contactors per I.E.C.**
- Control power terminals to accept incoming for 115-1-60 control power
- Fan contactors & overload current protection

The power wiring is fully contained inside the unit and secured in place.

** International Electrotechnical Commission

Options and Accessories

ELECTRICAL OPTIONS

SINGLE-POINT SUPPLY TERMINAL BLOCK – Standard. Includes enclosure, terminal-block and interconnecting wiring to the compressors. Separate external protection must be supplied, by others, in the incoming compressor-power wiring. (Do not include this option if either the SinglePoint NonFused Disconnect Switch or Single-Point Circuit Breaker options have been included.)

SINGLE-POINT NON-FUSED DISCONNECT SWITCH – Unit-mounted disconnect switch with external, lockable handle (in compliance with Article 440-14 of N.E.C.), can be supplied to isolate the unit power voltage for servicing. Separate external fusing must be supplied, by others in the power wiring, which must comply with the National Electrical Code and/or local codes.

SINGLE-POINT CIRCUIT BREAKER – A unit mounted circuit breaker with external, lockable handle (in compliance with N.E.C. Article 440-14), can be supplied to isolate the power voltage for servicing. (This option includes the Single-Point Power connection.)

CONTROL TRANSFORMER – Converts unit power voltage to 115-1-60 or 115-1-50 if 50Hz is selected (0.5 or 1.0 KVA capacity). Factory mounting includes primary and secondary wiring between the transformer and the control panel. (**Factory-mounted.**)

POWER FACTOR CORRECTION CAPACITORS – Will correct unit compressor power factors to 0.90-0.95. (**Factory-mounted.**)

CONTROL OPTIONS

AMBIENT KIT (LOW) – Standard units will operate to 25°F (-4°C). This accessory includes all necessary components to permit chiller operation to 0°F (-18°C). (This option includes the Discharge Pressure Transducer/Readout Capability option.) For proper head pressure control in applications below 25°F (-4°C), where wind gusts may exceed five mph, it is recommended that Optional Condenser Louvered Enclosure Panels also be included. (**Factory-mounted.**)

AMBIENT KIT (HIGH) – Required if units are to operate when the ambient temperature is above 110°F (43°C). Includes discharge pressure transducers. (This option includes the Discharge Pressure Transducer / Readout-Capability option.) (**Field-Mounted.**)

LANGUAGE LCD AND KEYPAD DISPLAY – Spanish, French, and German unit LCD controls and keypad display available. Standard language is English.

DISCHARGE PRESSURE TRANSDUCERS AND READ-OUT CAPABILITY – The addition of pressure transducers allows models to sense and display discharge pressure. This is recommended for glycol chilling applications. (This option is included with either the low or high ambient kits.) (**Factory-mounted.**)

SUCTION PRESSURE TRANSDUCERS – Permits unit to sense and display suction pressure. This capability is standard.

MOTOR CURRENT MODULE – Capable of monitoring compressor motor current. Provides extra protection against compressor reverse rotation, phase-loss and phase imbalance. Option consists of one module per electrical system. (**Factory-mounted.**)

COMPRESSOR, PIPING, EVAPORATOR OPTIONS

LOW TEMPERATURE GLYCOL – Required for glycol chilling below 30°F (-1°C) leaving glycol temperature. Option includes resized thermal expansion valve. (**Factory-mounted.**)

CHICAGO CODE RELIEF VALVES – Unit will be provided with relief valves to meet Chicago code requirements. (**Factory-mounted.**)

SERVICE ISOLATION VALVE – Service isolation valves are standard to unit. This includes a system high pressure relief valve or internal compressor relief mechanism in compliance with ASHRAE 15. (**Factory-mounted.**)

HOT GAS BY-PASS – Permits continuous, stable operation at capacities below the minimum step of compressor unloading to as low as 5% capacity (depending on both the unit and operating conditions) by introducing an artificial load on the cooler. Hot gas by-pass is installed on only refrigerant system #1 on two-circuit units. (**Factory-mounted.**)

DX COOLER 300 PSIG (21 BARG) DWP WATERSIDE – The waterside will be rated to 300 PSIG (21 barg) instead of the standard 150 PSIG DWP. 300 PSIG R.F. flanges are included on the DX cooler nozzles. The companion flanges will be field-supplied by others. (**Factory-mounted.**)

FLANGES (ANSI/AWWA C-606 COUPLINGS TYPE) – Consists of two (2) Flange adapters for grooved end pipe (standard 150 psi [10.5 barg] cooler).

FLOW SWITCH – The flow switch or its equivalent must be furnished with each unit.

Options and Accessories - continued

- **150 PSIG (10.5 BARG) DWP** – For standard units. Johnson Controls model F61MG-1C vaporproof SPDT, NEMA 4X switch (150 PSIG [10.5 barg] DWP), -20°F to 250°F (-29°C to 121°C), with 1" NPT connection for upright mounting in horizontal pipe. (**Field-mounted.**)
- **300 PSIG (21 BARG) DWP** – For units with optional 300 PSIG (21 barg) DX cooler. McDonnell & Miller model FS74W vaporproof SPDT, NEMA 4X switch (300 PSIG (21 barg) DWP), -20°F to 300°F (-29°C to 149°C), with 1¼ inch MPT connection for upright mounting in horizontal pipe. (**Field-mounted.**)

DIFFERENTIAL PRESSURE SWITCH – Alternative to an above mentioned flow switch. Pretempco model DP-S300AP40PF-82582-5 (300 psig [21 barg] max. working pressure), SPDT 5 amp 125/250VAC switch, Range 3-45 PSIG (0.2-3 barg), deadband 0.5 - 0.8 psi (0.003 - 0.005 barg), with 1/4" NPTE Pressure Connections.

CONDENSER AND CABINET OPTIONS

Condenser coil protection against corrosive environments is available by choosing any of the following options. For additional application recommendations, contact your local Johnson Controls office. (**Factory-mounted.**)

PRE-COATED FIN CONDENSER COILS – The unit's coils are constructed with epoxy coated aluminum fins. This can provide corrosion resistance comparable to copper-fin coils in typical seashore locations. Either these or the post-coated coils (below), are recommended for units being installed at the seashore or where salt spray may hit the unit.

POST-COATED DIPPED CONDENSER COILS – The unit's coils are constructed with dipped-cured condenser coils. This is the choice for corrosive applications (with the exception of strong alkalis, oxidizers and wet bromine, chlorine and fluorine in concentrations greater than 100 ppm).

COPPER FIN CONDENSER COILS – The unit coils are constructed with copper fins. (This is not recommended for units in areas where they may be exposed to acid rain.)

ENCLOSURE PANELS (UNIT) – Tamperproof enclosure panels prevent unauthorized access to units. Enclosure panels can provide an aesthetically pleasing alternative to expensive fencing.

LOUVERED PANELS (FULL UNIT) – Louvered panels surround the front, back, and sides of the unit. They prevent unauthorized access and visually screen unit components. Unrestricted air flow is permitted through generously sized louvered openings. This option is applicable for any outdoor design ambient temperature up to 115°F (46°C). Recommended for use with the Low Ambient kit where wind gusts may exceed five mph (eight kph). (**Factory-mounted.**)

SOUND ATTENUATION – One or both of the following sound attenuation options are recommended for residential or other similar sound-sensitive locations.

COMPRESSOR ACOUSTIC SOUND BLANKET – Each compressor is individually enclosed by an acoustic sound blanket. The sound blankets are made with one layer of acoustical absorbent textile fiber of 5/8" (15mm) thickness; one layer of anti-vibrating heavy material thickness of 1/8" (3mm). Both are closed by two sheets of welded PVC, reinforced for temperature and UV resistance. (**Factory-mounted.**)

ULTRA QUIET FANS – Lower RPM, eight-pole fan motors are used with steeper-pitch fans. (**Factory-mounted.**)

VIBRATION ISOLATORS – Level adjusting, spring type 1" (25.4mm) or 2" deflection or neoprene pad isolators for mounting under unit base rails. (**Field-mounted.**)

INTENTIONALLY LEFT BLANK

Unit Nomenclature

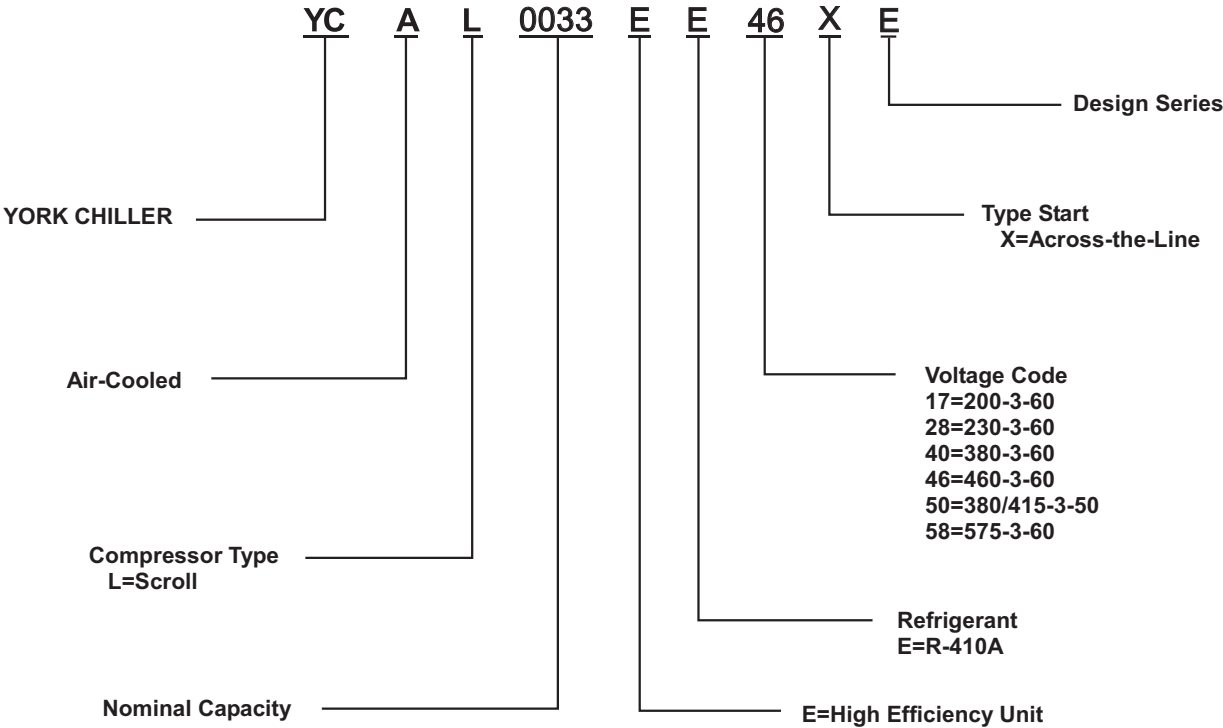

Selection Data

GUIDE TO SELECTION

Capacity ratings for the YCAL Packaged Air-Cooled Liquid Chillers, shown on pages 16 through 48 cover the majority of design applications for these units. For unusual applications or uses beyond the scope of this catalog, please consult your nearest Johnson Controls Office or sales representative.

Selection Rules

- Ratings** – Ratings may be interpolated, but must not be extrapolated. The Ratings given on pages 18 through 37 and the DESIGN PARAMETERS given on page 13 indicate the limits of application for these chillers.
- Cooler Water** – Ratings are based upon 2.4 GPM per ton which is equal to a 10°F chilled water range and a 0.0001 fouling factor for the cooler at sea level. Tables on pages 18 through 48 give capacity, compressor kW required, cooler GPM and unit EER.
- Condenser** – Ratings are given in terms of air on condenser in degrees Fahrenheit.
- Copper Fin Condenser Ratings** – Since the thermal conductivity of copper is slightly higher than aluminum, apply the following corrections to the standard ratings. Tons x 0.97 and compressor kW x 0.99.
- Performance Data Correction Factors** – Ratings are based on 0.0001 cooler fouling factor, 10°F chilled water range and at sea level. For operation at different conditions, apply the appropriate correction factor from the following table.

FOULING FACTOR					
ALTITUDE	TEMP SPLIT	0.0001		0.0003	
		TONS	COMPR kW	TONS	COMPR kW
SEA LEVEL	8	0.990	0.998	0.979	0.996
	10	1.000	1.000	0.991	0.998
	12	1.012	1.003	1.002	1.001
	14	1.021	1.005	1.012	1.003
2000 FT.	8	0.987	1.005	0.978	1.003
	10	0.997	1.008	0.988	1.006
	12	1.009	1.010	1.000	1.008
	14	1.018	1.012	1.009	1.010
4000 FT.	8	0.983	1.014	0.975	1.012
	10	0.994	1.016	0.985	1.014
	12	1.005	1.019	1.111	1.017
	14	1.014	1.021	1.006	1.019
6000 FT.	8	0.980	1.023	0.971	1.021
	10	0.990	1.025	0.982	1.023
	12	1.002	1.028	0.993	1.026
	14	1.011	1.030	1.002	1.028

- Ethylene Glycol Correction Factors** – The following factors are to be applied to the standard ratings for units cooling ethylene glycol.

ETHYLENE GLYCOL					
% WEIGHT	TONS	COMPR KW	GPM °F/ TON	PRESS DROP	FREEZE PT
10	0.996	0.999	24.300	1.014	26.2
20	0.991	0.998	25.100	1.104	17.9
30	0.984	0.997	25.900	1.234	6.7
40	0.976	0.995	26.900	1.399	-8.1
50	0.968	0.994	28.000	1.599	-28.9

- Propylene Glycol Correction Factors** – The following factors are to be applied to the standard ratings for units cooling propylene glycol.

PROPYLENE GLYCOL					
% WEIGHT	TONS	COMPR KW	GPM °F/ TON	PRESS DROP	FREEZE PT
10	0.995	0.999	24.000	1.049	26
20	0.984	0.997	24.300	1.124	19
30	0.973	0.994	24.900	1.258	9
40	0.960	0.992	25.600	1.430	-6
50	0.943	0.989	26.600	1.650	-28

METHOD OF SELECTION

To select a YORK Packaged Air-Cooled Liquid Chiller, the following data must be known:

- Design Capacity in tons refrigeration (TR).
- Entering and Leaving Liquid Temperatures.
- Outside ambient air temperature in °F.
- GPM of chilled liquid.

Determine capacity requirements from the following formula:

$$\text{GPM} = \frac{\text{TR} \times 24}{\text{RANGE } (^\circ\text{F})}$$

EXAMPLE – WATER CHILLING

- Given: Provide a capacity of 50 tons at 42°F leaving water at 10°F range. 0.0001FF, 85°F air on the condenser, at sea level and 60 Hz.
- Find: Unit Size, Compressor KW Output
- From the ratings on page 18.

Selection Data - cont.

SELECT: **YCAL0056**(English Units)

- a. 54.4 Tons
 - b. 51.8 Compressor KW
 - c. 11.1 Unit EER
4. Calculate Compressor kW at 50 Tons:

$$\text{kW} = \frac{50}{54.4} \times 51.8 \text{kW} = 47.6 \text{kW}$$

5. Calculate GPM:

$$\text{GPM} = \frac{(50\text{Tons}) \times 24}{10^\circ\text{F Range}} = 120\text{GPM}$$

6. From page 16, read 6 ft of water cooler pressure drop from GPM: 16

7. A **YCAL0056** is suitable.

EXAMPLE - BRINE CHILLING

Example - Brine Chilling

1. Given: Provide a capacity of 34 tons cooling 30% by weight Ethylene Glycol from 50°F to 40°F, 0.00025FF, 95°F air on the condenser, 60°Hz and 4000 ft. altitude.
2. Determine:
 - a. Unit Size
 - b. KW Input
 - c. Ethylene Glycol GPM
 - d. Cooler Pressure Drop
3. See E.G. correction factors, for 30% by weight E.G.

READ: 0.984 Tons Factor

0.997 Compr. KW factor

26.1 Gal/ F/Tons Factor

4. See Performance Data Correction Factors for 0.00025 fouling factor and 4,000 ft. altitude.

READ: 0.975 Tons factor

1.012 kW factor

5. From RATINGS on page 16.

SELECT: **YCAL0046** (English Units)

35.3 Tons

41.1 Compressor kW

6. Determine YCAL0046 glycol cooling capacity and Compressor kW requirement from pg 18:

a. TONS: = 35.3 x 0.984 x 0.975 = 33.87

b. Compr. KW = 41.1 x 0.997 x 1.012 = 41.77

7. Determine average full load Compressor kW at 34 tons

$$\frac{34 \text{ Tons}}{33.87 \text{ Tons}} \times (41.77) = 41.93 \text{ Compressor kW}$$

8. Determine E.G. GPM:

$$\text{GPM} = \frac{\text{Tons} \times \text{Gal } ^\circ\text{F} / \text{min} / \text{Ton factor}}{\text{Range}}$$

$$\text{GPM} = \frac{34.0 \times 26.1}{10} = 88.7(\text{GPM})$$

9. Determine Cooler Pressure Drop:

- a. See E.G. correction factors for 30% by weight E.G.

READ: 1.258 Pressure Drop factor

- b. See page 14 at 88.7 GPM for YCAL0046

READ: 3.0 Water PD

- c. Cooler Pressure Drop = 3.0 x 1.258 or 3.77 ft.

10. A **YCAL0046** is suitable.

Design Parameters

ENGLISH

YCAL	LEAVING WATER TEMPERATURE (°F)		COOLER FLOW (GPM)		AIR ON CONDENSER (°F)	
	MIN	MAX	MIN	MAX	MIN	MAX
0019EE	40	55	10	150	0	125
0022EE	40	55	10	150	0	125
0028EE	40	55	10	150	0	125
0033EE	40	55	10	150	0	125
0043EE	40	55	40	200	0	125
0046EE	40	55	40	200	0	125
0052EE	40	55	60	300	0	125
0056EE	40	55	60	300	0	125
0066EE	40	55	60	300	0	125

SI UNITS

YCAL	LEAVING WATER TEMPERATURE (°C)		COOLER FLOW (L/S)		AIR ON CONDENSER (°C)	
	MIN	MAX	MIN	MAX	MIN	MAX
0019EE	4.4	12.8	0.6	9.5	-17.7	51.7
0022EE	4.4	12.8	0.6	9.5	-17.7	51.7
0028EE	4.4	12.8	0.6	9.5	-17.7	51.7
0033EE	4.4	12.8	0.6	9.5	-17.7	51.7
0043EE	4.4	12.8	2.5	12.6	-17.7	51.7
0046EE	4.4	12.8	2.5	12.6	-17.7	51.7
0052EE	4.4	12.8	3.8	18.9	-17.7	51.7
0056EE	4.4	12.8	3.8	18.9	-17.7	51.7
0066EE	4.4	12.8	3.8	18.9	-17.7	51.7

NOTES:

1. For leaving brine temperature below 40°F (4.4°C), contact your nearest Johnson Controls Office for application requirements.
2. For leaving water temperature higher than 55°F (12.8°C), contact the nearest Johnson Controls Office for application guidelines.
3. The evaporator is protected against freezing to -20°F (-28.8°C) with an electric heater as standard.
4. For operation at temperatures below 25°F (-3.9°C), the optional Low Ambient Kit will need to be installed on the system (for YCAL0043-0065 models only).
5. For operation at temperatures above 115°F (46.1°C), the optional High Ambient Kit will need to be installed on the system.

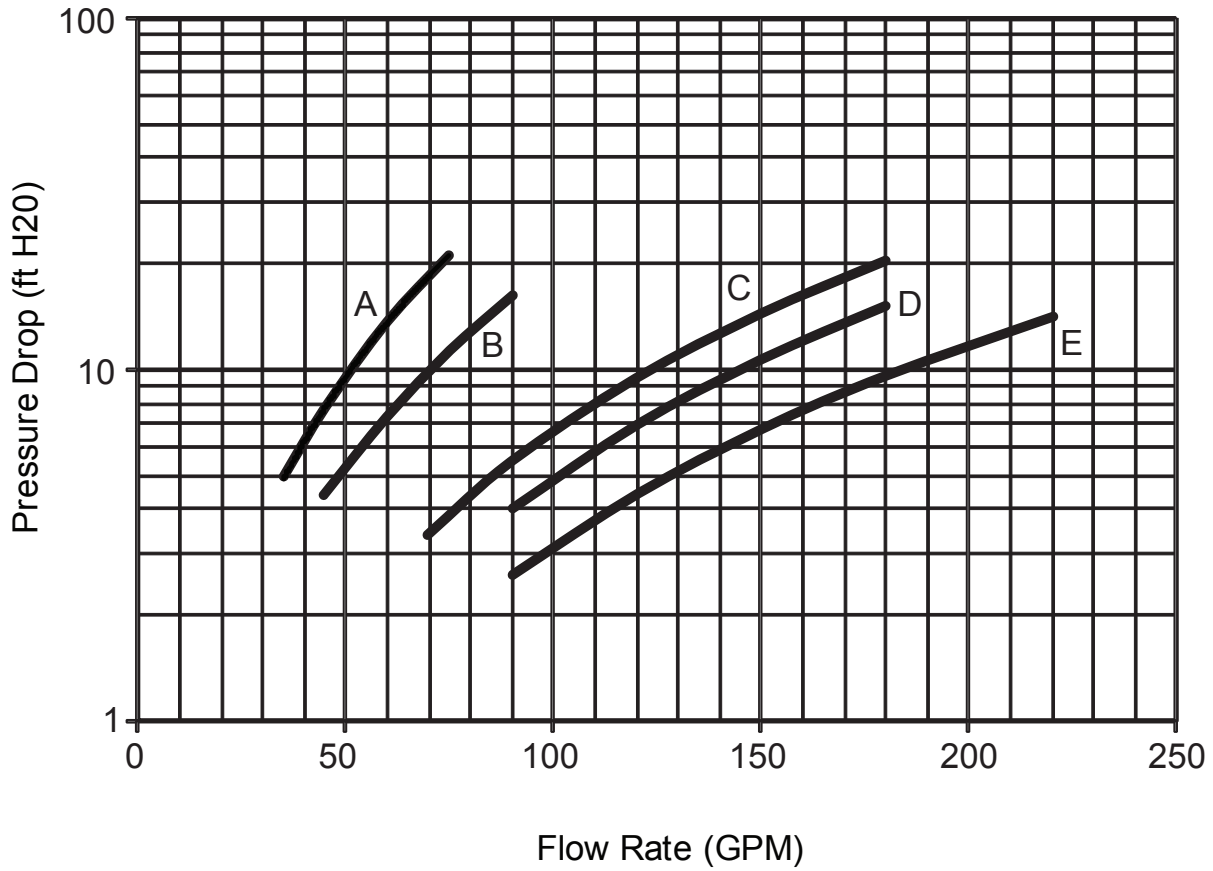

Chiller Model	Evaporator Curve
YCAL0019EE	A
YCAL0022EE	B
YCAL0028EE	B
YCAL0033EE	B
YCAL0043EE	C
YCAL0046EE	D
YCAL0052EE	C
YCAL0056EE	D
YCAL0066EE	E

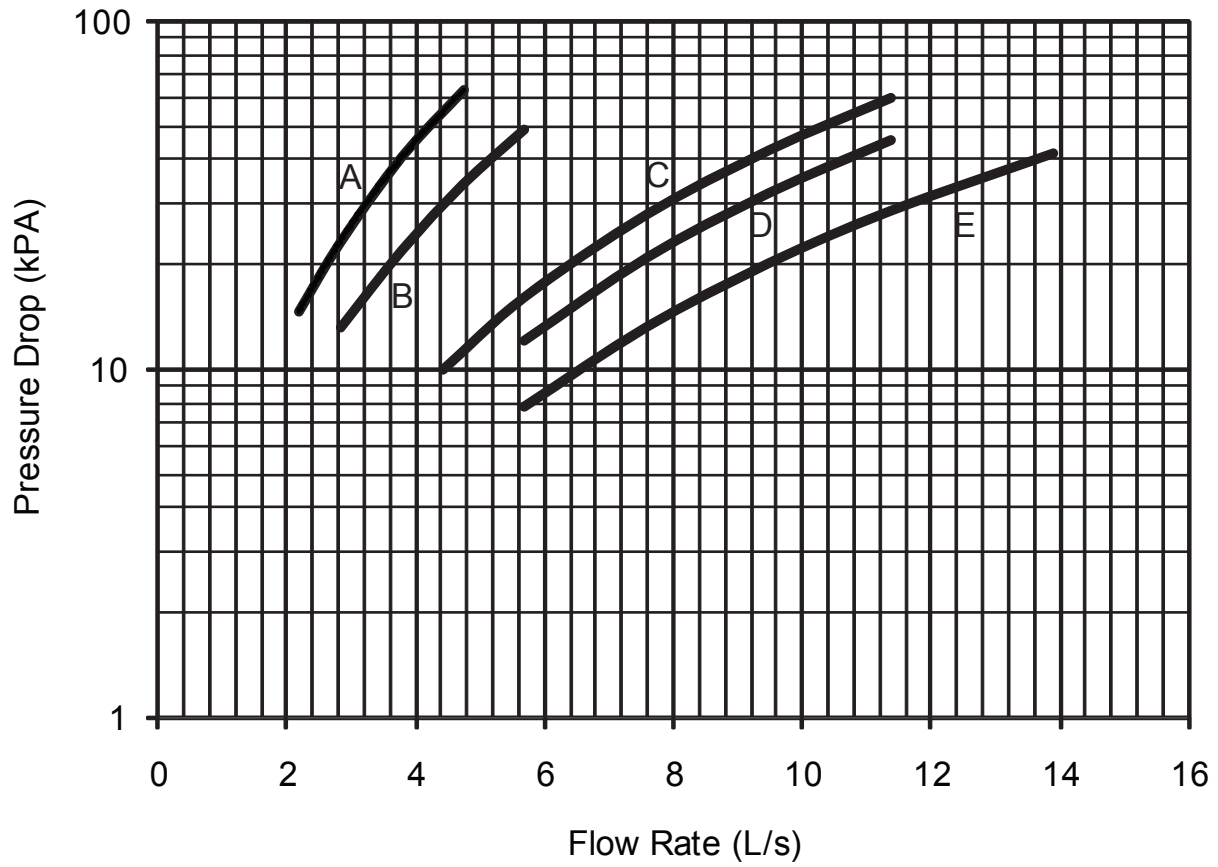

Chiller Model	Evaporator Curve
YCAL0019EE	A
YCAL0022EE	B
YCAL0028EE	B
YCAL0033EE	B
YCAL0043EE	C
YCAL0046EE	D
YCAL0052EE	C
YCAL0056EE	D
YCAL0066EE	E

Ratings - R-410A (60Hz - English Units)

MODEL: YCAL0019EE													IPLV = 14.6		
AIR TEMPERATURE ON CONDENSER (°F)															
LCWT (°F)	75.0			80.0			85.0			90.0			95.0		
	TONS	KW	EER	TONS	KW	EER	TONS	KW	EER	TONS	KW	EER	TONS	KW	EER
40.0	16.2	13.6	13.3	15.8	14.4	12.3	15.3	15.3	11.3	14.9	16.3	10.3	14.4	17.3	9.5
42.0	16.7	13.7	13.6	16.3	14.6	12.6	15.9	15.5	11.6	15.4	16.4	10.6	14.9	17.4	9.7
44.0	17.3	13.9	14.0	16.8	14.7	12.9	16.4	15.6	11.9	15.9	16.6	10.9	15.4	17.6	10.0
45.0	17.6	13.9	14.1	17.1	14.8	13.0	16.7	15.7	12.0	16.2	16.6	11.0	15.7	17.6	10.1
46.0	17.8	14.0	14.3	17.4	14.8	13.2	16.9	15.7	12.1	16.5	16.7	11.2	16.0	17.7	10.2
48.0	18.4	14.1	14.6	18.0	15.0	13.5	17.5	15.9	12.4	17.0	16.8	11.4	16.5	17.9	10.5
50.0	19.0	14.3	14.9	18.5	15.1	13.8	18.0	16.0	12.7	17.5	17.0	11.7	17.0	18.0	10.7

MODEL: YCAL0022EE													IPLV = 15.5		
AIR TEMPERATURE ON CONDENSER (°F)															
LCWT (°F)	75.0			80.0			85.0			90.0			95.0		
	TONS	KW	EER	TONS	KW	EER	TONS	KW	EER	TONS	KW	EER	TONS	KW	EER
40.0	19.9	16.7	13.5	19.4	17.6	12.5	18.8	18.7	11.4	18.1	19.9	10.4	17.5	21.1	9.5
42.0	20.6	16.8	13.8	20.0	17.8	12.8	19.4	18.9	11.7	18.7	20.0	10.7	18.1	21.3	9.7
44.0	21.2	17.0	14.2	20.7	18.0	13.1	20.0	19.1	12.0	19.4	20.2	11.0	18.7	21.5	10.0
45.0	21.6	17.1	14.3	21.0	18.1	13.2	20.4	19.2	12.1	19.7	20.3	11.1	19.0	21.6	10.1
46.0	21.9	17.2	14.5	21.3	18.2	13.3	20.7	19.3	12.3	20.0	20.4	11.2	19.3	21.7	10.2
48.0	22.6	17.4	14.8	22.0	18.4	13.6	21.4	19.4	12.5	20.7	20.6	11.5	20.0	21.9	10.5
50.0	23.3	17.5	15.1	22.7	18.6	13.9	22.0	19.6	12.8	21.3	20.8	11.7	20.6	22.1	10.7

MODEL: YCAL0028EE													IPLV = 13.4		
AIR TEMPERATURE ON CONDENSER (°F)															
LCWT (°F)	75.0			80.0			85.0			90.0			95.0		
	TONS	KW	EER	TONS	KW	EER	TONS	KW	EER	TONS	KW	EER	TONS	KW	EER
40.0	26.5	22.0	12.8	25.9	23.1	11.9	25.3	24.3	11.1	24.6	25.6	10.3	23.9	27.1	9.5
42.0	27.4	22.2	13.1	26.8	23.3	12.2	26.1	24.5	11.4	25.5	25.8	10.6	24.7	27.3	9.8
44.0	28.4	22.4	13.4	27.7	23.5	12.5	27.0	24.7	11.7	26.3	26.1	10.9	25.6	27.5	10.1
45.0	28.8	22.5	13.6	28.2	23.6	12.7	27.5	24.9	11.8	26.8	26.2	11.0	26.0	27.6	10.2
46.0	29.3	22.6	13.7	28.6	23.7	12.9	27.9	25.0	12.0	27.2	26.3	11.1	26.4	27.7	10.3
48.0	30.3	22.8	14.1	29.6	24.0	13.2	28.8	25.2	12.3	28.1	26.5	11.4	27.3	27.9	10.6
50.0	31.3	23.1	14.4	30.5	24.2	13.5	29.8	25.4	12.6	29.0	26.8	11.7	28.2	28.2	10.9

NOTES:

1. kW = Compressor Input Power
2. EER = Chiller EER (includes power from compressors, fans, and the control panels 0.8 kW)
3. LCWT = Leaving Chilled Water Temperature
4. Ratings are based upon 2.4 GPM cooler water per ton and 0.0001 fouling factor
5. Rated in accordance with the latest version of ARI Standard 550/590
6. The shaded points are certified in accordance with the latest version of ARI Standard 550/590

MODEL: YCAL0019EE																	IPLV = 14.6		
AIR TEMPERATURE ON CONDENSER (°F)																			
LCWT (°F)	100.0			105.0			110.0			115.0			120.0			125.0			
	TONS	KW	EER	TONS	KW	EER	TONS	KW	EER	TONS	KW	EER	TONS	KW	EER	TONS	KW	EER	
40.0	14.0	18.4	8.6	13.5	19.6	7.8	13.0	20.9	7.1	12.4	22.2	6.4	6.6	10.2	7.0	6.3	10.9	6.4	
42.0	14.5	18.5	8.9	13.9	19.7	8.1	13.4	21.0	7.3	12.9	22.3	6.6	6.8	10.2	7.3	6.5	10.9	6.6	
44.0	14.9	18.7	9.1	14.4	19.9	8.3	13.9	21.1	7.5	13.3	22.4	6.8	7.1	10.3	7.6	6.8	10.9	6.8	
45.0	15.2	18.7	9.2	14.7	19.9	8.4	14.1	21.2	7.6	13.5	22.5	6.9	7.2	10.3	7.7	6.9	10.9	7.0	
46.0	15.4	18.8	9.4	14.9	20.0	8.5	14.3	21.2	7.7	13.8	22.6	7.0	7.3	10.3	7.8	7.0	10.9	7.1	
48.0	15.9	19.0	9.6	15.4	20.1	8.7	14.8	21.4	8.0	7.9	9.7	8.9	7.6	10.3	8.1	7.3	11.0	7.3	
50.0	16.5	19.1	9.8	15.9	20.3	9.0	15.3	21.5	8.2	8.2	9.7	9.2	7.9	10.4	8.3	7.6	11.0	7.6	

MODEL: YCAL0022EE																	IPLV = 15.5		
AIR TEMPERATURE ON CONDENSER (°F)																			
LCWT (°F)	100.0			105.0			110.0			115.0			120.0			125.0			
	TONS	KW	EER	TONS	KW	EER	TONS	KW	EER	TONS	KW	EER	TONS	KW	EER	TONS	KW	EER	
40.0	16.8	22.4	8.6	16.1	23.9	7.8	15.4	25.4	7.0	14.7	27.0	6.3	7.9	12.2	7.1	7.5	13.0	6.4	
42.0	17.4	22.6	8.8	16.7	24.1	8.0	16.0	25.6	7.2	8.6	11.5	8.2	8.2	12.3	7.4	7.8	13.1	6.6	
44.0	18.0	22.8	9.1	17.3	24.2	8.2	16.5	25.8	7.4	8.9	11.6	8.5	8.5	12.3	7.7	8.1	13.1	6.9	
45.0	18.3	22.9	9.2	17.6	24.3	8.3	16.8	25.9	7.5	9.1	11.6	8.6	8.7	12.4	7.8	8.2	13.1	7.0	
46.0	18.6	23.0	9.3	17.9	24.4	8.4	17.1	25.9	7.6	9.2	11.6	8.8	8.8	12.4	7.9	8.4	13.2	7.1	
48.0	19.2	23.2	9.5	18.5	24.6	8.6	17.7	26.1	7.8	9.6	11.7	9.1	9.2	12.4	8.2	8.7	13.2	7.4	
50.0	19.9	23.4	9.8	19.1	24.9	8.9	18.3	26.4	8.0	9.9	11.7	9.3	9.5	12.5	8.4				

MODEL: YCAL0028EE																	IPLV = 13.4		
AIR TEMPERATURE ON CONDENSER (°F)																			
LCWT (°F)	100.0			105.0			110.0			115.0			120.0			125.0			
	TONS	KW	EER	TONS	KW	EER	TONS	KW	EER	TONS	KW	EER	TONS	KW	EER	TONS	KW	EER	
40.0	23.2	28.6	8.8	22.4	30.2	8.1	21.6	31.9	7.4	20.8	33.7	6.8	19.9	35.7	6.2	11.0	18.5	6.1	
42.0	24.0	28.8	9.1	23.2	30.4	8.3	22.4	32.1	7.7	21.5	33.9	7.0	20.6	35.9	6.4	11.5	18.6	6.4	
44.0	24.8	29.0	9.3	24.0	30.6	8.6	23.1	32.3	7.9	22.3	34.1	7.2	21.3	36.1	6.6	11.9	18.7	6.6	
45.0	25.2	29.1	9.4	24.4	30.7	8.7	23.5	32.4	8.0	22.6	34.2	7.3	21.7	36.2	6.7	12.1	18.7	6.7	
46.0	25.6	29.2	9.6	24.8	30.8	8.8	23.9	32.5	8.1	23.0	34.3	7.4	22.1	36.3	6.7	12.3	18.8	6.8	
48.0	26.5	29.4	9.8	25.6	31.0	9.0	24.7	32.7	8.3	23.8	34.6	7.6	22.8	36.5	6.9	12.8	18.9	7.0	
50.0	27.4	29.7	10.0	26.5	31.3	9.3	25.6	33.0	8.5	24.6	34.8	7.8	23.6	36.7	7.1	13.2	19.0	7.2	

NOTES:

1. kW = Compressor Input Power
2. EER = Chiller EER (includes power from compressors, fans, and the control panels 0.8 kW)
3. LCWT = Leaving Chilled Water Temperature
4. Ratings are based upon 2.4 GPM cooler water per ton and 0.0001 fouling factor
5. Rated in accordance with the latest version of ARI Standard 550/590
6. The shaded points are certified in accordance with the latest version of ARI Standard 550/590

Ratings - R-410A (60Hz - English Units) - continued

MODEL: YCAL0033EE													IPLV = 14.5		
AIR TEMPERATURE ON CONDENSER (°F)															
LCWT (°F)	75.0			80.0			85.0			90.0			95.0		
	TONS	KW	EER	TONS	KW	EER	TONS	KW	EER	TONS	KW	EER	TONS	KW	EER
40.0	29.7	23.8	13.3	29.0	25.0	12.4	28.3	26.3	11.6	27.5	27.7	10.8	26.7	29.2	10.0
42.0	30.7	24.0	13.6	30.0	25.2	12.8	29.2	26.5	11.9	28.5	27.9	11.1	27.6	29.4	10.2
44.0	31.7	24.2	14.0	31.0	25.4	13.1	30.2	26.7	12.2	29.4	28.1	11.3	28.6	29.6	10.5
45.0	32.2	24.4	14.1	31.5	25.6	13.2	30.7	26.9	12.3	29.9	28.3	11.5	29.0	29.8	10.6
46.0	32.7	24.5	14.3	32.0	25.7	13.4	31.2	27.0	12.5	30.4	28.4	11.6	29.5	29.9	10.8
48.0	33.7	24.8	14.6	33.0	26.0	13.7	32.2	27.3	12.8	31.4	28.7	11.9	30.5	30.2	11.0
50.0	34.8	25.1	14.9	34.0	26.3	14.0	33.2	27.6	13.0	32.3	29.0	12.1	31.4	30.5	11.3

MODEL: YCAL0043EE													IPLV = 14.5		
AIR TEMPERATURE ON CONDENSER (°F)															
LCWT (°F)	75.0			80.0			85.0			90.0			95.0		
	TONS	KW	EER	TONS	KW	EER	TONS	KW	EER	TONS	KW	EER	TONS	KW	EER
40.0	38.7	30.8	12.8	37.8	32.3	11.9	36.8	34.1	11.1	35.7	36.2	10.3	34.6	38.4	9.4
42.0	40.0	31.0	13.1	39.1	32.5	12.3	38.1	34.3	11.5	37.1	36.4	10.6	35.9	38.6	9.8
44.0	41.4	31.1	13.5	40.5	32.7	12.7	39.5	34.6	11.8	38.4	36.6	10.9	37.2	38.8	10.1
45.0	42.1	31.2	13.7	41.1	32.8	12.8	40.1	34.7	12.0	39.1	36.7	11.1	37.9	38.9	10.2
46.0	42.7	31.3	13.9	41.8	32.9	13.0	40.8	34.8	12.1	39.7	36.8	11.3	38.6	39.0	10.4
48.0	44.1	31.5	14.3	43.2	33.2	13.4	42.2	35.0	12.5	41.1	37.0	11.6	39.9	39.3	10.7
50.0	45.6	31.7	14.6	44.7	33.4	13.8	43.6	35.2	12.8	42.5	37.3	11.9	41.3	39.5	11.0

MODEL: YCAL0046EE													IPLV = 14.7		
AIR TEMPERATURE ON CONDENSER (°F)															
LCWT (°F)	75.0			80.0			85.0			90.0			95.0		
	TONS	KW	EER	TONS	KW	EER	TONS	KW	EER	TONS	KW	EER	TONS	KW	EER
40.0	41.0	32.4	13.0	40.0	34.2	12.1	39.0	36.1	11.2	37.9	38.2	10.4	36.7	40.5	9.5
42.0	42.5	32.6	13.3	41.4	34.4	12.4	40.4	36.3	11.6	39.2	38.4	10.7	38.1	40.8	9.9
44.0	43.9	32.9	13.7	42.9	34.6	12.8	41.8	36.6	11.9	40.6	38.7	11.0	39.4	41.0	10.2
45.0	44.7	33.0	13.9	43.6	34.8	13.0	42.5	36.7	12.1	41.4	38.8	11.2	40.1	41.1	10.3
46.0	45.4	33.1	14.1	44.4	34.9	13.1	43.2	36.8	12.2	42.1	39.0	11.3	40.8	41.3	10.5
48.0	46.9	33.4	14.4	45.9	35.2	13.5	44.7	37.1	12.6	43.5	39.2	11.7	42.3	41.5	10.8
50.0	48.5	33.6	14.8	47.4	35.4	13.9	46.2	37.4	12.9	45.0	39.5	12.0	43.7	41.8	11.1

NOTES:

1. kW = Compressor Input Power
2. EER = Chiller EER (includes power from compressors, fans, and the control panels 0.8 kW)
3. LCWT = Leaving Chilled Water Temperature
4. Ratings are based upon 2.4 GPM cooler water per ton and 0.0001 fouling factor
5. Rated in accordance with the latest version of ARI Standard 550/590
6. The shaded points are certified in accordance with the latest version of ARI Standard 550/590

MODEL: YCAL0033EE																	IPLV= 14.5		
AIR TEMPERATURE ON CONDENSER (°F)																			
LCWT (°F)	100.0			105.0			110.0			115.0			120.0			125.0			
	TONS	KW	EER	TONS	KW	EER	TONS	KW	EER	TONS	KW	EER	TONS	KW	EER	TONS	KW	EER	
40.0	25.9	30.8	9.2	25.0	32.5	8.5	24.1	34.3	7.8	23.2	36.2	7.1	22.2	38.3	6.4	11.6	18.3	6.5	
42.0	26.8	31.0	9.5	25.9	32.7	8.7	24.9	34.5	8.0	24.0	36.5	7.3	23.0	38.5	6.6	12.1	18.4	6.8	
44.0	27.7	31.2	9.7	26.8	33.0	8.9	25.8	34.8	8.2	24.8	36.7	7.5	23.8	38.8	6.8	12.5	18.4	7.0	
45.0	28.1	31.4	9.8	27.2	33.1	9.0	26.2	34.9	8.3	25.2	36.8	7.6	24.2	38.9	6.9	12.7	18.5	7.1	
46.0	28.6	31.5	9.9	27.7	33.2	9.2	26.7	35.0	8.4	25.7	37.0	7.7	24.6	39.0	7.0	13.0	18.5	7.2	
48.0	29.5	31.8	10.2	28.6	33.5	9.4	27.6	35.3	8.6	26.5	37.2	7.9	25.4	39.3	7.2	13.4	18.6	7.5	
50.0	30.5	32.1	10.4	29.5	33.8	9.6	28.5	35.6	8.9	27.4	37.5	8.1	14.5	17.8	8.4	13.9	18.7	7.7	

MODEL: YCAL0043EE																	IPLV= 14.5		
AIR TEMPERATURE ON CONDENSER (°F)																			
LCWT (°F)	100.0			105.0			110.0			115.0			120.0			125.0			
	TONS	KW	EER	TONS	KW	EER	TONS	KW	EER	TONS	KW	EER	TONS	KW	EER	TONS	KW	EER	
40.0	33.5	40.9	8.6	32.2	43.6	7.9	30.9	46.5	7.1	29.6	49.7	6.4	28.2	53.1	5.8	14.3	25.5	5.5	
42.0	34.7	41.1	8.9	33.5	43.8	8.1	32.2	46.7	7.4	30.8	49.8	6.7	29.4	53.2	6.0	15.0	25.5	5.8	
44.0	36.0	41.3	9.2	34.7	44.0	8.4	33.4	46.8	7.6	32.0	50.0	6.9	30.6	53.3	6.2	15.6	25.5	6.0	
45.0	36.7	41.4	9.4	35.4	44.1	8.6	34.0	46.9	7.8	32.6	50.0	7.0	31.2	53.4	6.3	15.9	25.5	6.1	
46.0	37.3	41.5	9.5	36.0	44.2	8.7	34.7	47.0	7.9	33.2	50.1	7.2	31.8	53.5	6.5	16.2	25.5	6.3	
48.0	38.7	41.7	9.8	37.4	44.4	9.0	36.0	47.2	8.2	34.5	50.3	7.4	33.0	53.6	6.7	16.9	25.6	6.5	
50.0	40.1	42.0	10.1	38.7	44.6	9.2	37.3	47.5	8.4	35.8	50.5	7.6	34.2	53.8	6.9	17.6	25.6	6.8	

MODEL: YCAL0046EE																	IPLV= 14.7		
AIR TEMPERATURE ON CONDENSER (°F)																			
LCWT (°F)	100.0			105.0			110.0			115.0			120.0			125.0			
	TONS	KW	EER	TONS	KW	EER	TONS	KW	EER	TONS	KW	EER	TONS	KW	EER	TONS	KW	EER	
40.0	35.4	43.0	8.7	34.2	45.7	8.0	32.8	48.6	7.3	31.4	51.7	6.6	30.0	55.1	5.9	15.2	26.4	5.7	
42.0	36.8	43.2	9.0	35.5	45.9	8.3	34.1	48.8	7.5	32.7	51.9	6.8	31.2	55.2	6.2	15.9	26.4	5.9	
44.0	38.2	43.5	9.3	36.8	46.2	8.5	35.4	49.1	7.8	34.0	52.1	7.1	32.4	55.4	6.4	16.5	26.5	6.2	
45.0	38.9	43.6	9.5	37.5	46.3	8.7	36.1	49.2	7.9	34.6	52.3	7.2	33.1	55.6	6.5	16.9	26.5	6.3	
46.0	39.5	43.8	9.6	38.2	46.4	8.8	36.8	49.3	8.0	35.3	52.4	7.3	33.7	55.7	6.6	17.2	26.5	6.4	
48.0	40.9	44.0	9.9	39.6	46.7	9.1	38.1	49.6	8.3	36.6	52.6	7.5	35.0	55.9	6.8	17.9	26.6	6.7	
50.0	42.4	44.3	10.2	41.0	47.0	9.3	39.5	49.8	8.5	37.9	52.9	7.8	36.3	56.2	7.1	18.6	26.7	6.9	

NOTES:

1. kW = Compressor Input Power
2. EER = Chiller EER (includes power from compressors, fans, and the control panels 0.8 kW)
3. LCWT = Leaving Chilled Water Temperature
4. Ratings are based upon 2.4 GPM cooler water per ton and 0.0001 fouling factor
5. Rated in accordance with the latest version of ARI Standard 550/590
6. The shaded points are certified in accordance with the latest version of ARI Standard 550/590

Ratings - R-410A (60Hz - English Units) - continued

MODEL: YCAL0052EE													IPLV = 15.1		
AIR TEMPERATURE ON CONDENSER (°F)															
LCWT (°F)	75.0			80.0			85.0			90.0			95.0		
	TONS	KW	EER	TONS	KW	EER	TONS	KW	EER	TONS	KW	EER	TONS	KW	EER
40.0	47.7	38.0	12.8	46.6	40.1	12.0	45.5	42.3	11.1	44.3	44.7	10.3	43.1	47.2	9.6
42.0	49.4	38.3	13.2	48.3	40.4	12.3	47.1	42.6	11.5	45.9	45.0	10.6	44.7	47.6	9.9
44.0	51.2	38.7	13.5	50.0	40.8	12.6	48.8	43.0	11.8	47.5	45.4	10.9	46.2	47.9	10.2
45.0	52.0	38.9	13.7	50.8	40.9	12.8	49.6	43.2	11.9	48.3	45.5	11.1	47.0	48.1	10.3
46.0	52.9	39.0	13.9	51.7	41.1	13.0	50.5	43.3	12.1	49.2	45.7	11.3	47.8	48.3	10.4
48.0	54.8	39.4	14.2	53.5	41.5	13.3	52.2	43.7	12.4	50.9	46.1	11.6	49.5	48.6	10.7
50.0	56.6	39.8	14.6	55.3	41.9	13.7	54.0	44.1	12.7	52.6	46.5	11.9	51.1	49.0	11.0

MODEL: YCAL0056EE													IPLV = 14.7		
AIR TEMPERATURE ON CONDENSER (°F)															
LCWT (°F)	75.0			80.0			85.0			90.0			95.0		
	TONS	KW	EER	TONS	KW	EER	TONS	KW	EER	TONS	KW	EER	TONS	KW	EER
40.0	58.2	48.2	12.7	56.9	50.7	11.9	55.5	53.3	11.1	54.1	56.2	10.3	52.5	59.3	9.5
42.0	60.2	48.7	13.0	58.9	51.2	12.2	57.5	53.8	11.4	55.9	56.7	10.6	54.3	59.8	9.8
44.0	62.3	49.2	13.4	60.9	51.7	12.5	59.4	54.4	11.7	57.9	57.2	10.9	56.2	60.3	10.1
45.0	63.3	49.5	13.5	61.9	52.0	12.7	60.4	54.6	11.8	58.8	57.5	11.0	57.2	60.6	10.2
46.0	64.4	49.7	13.7	62.9	52.2	12.8	61.4	54.9	12.0	59.8	57.8	11.1	58.1	60.9	10.3
48.0	66.5	50.3	14.0	65.0	52.8	13.1	63.5	55.5	12.2	61.8	58.3	11.4	60.0	61.4	10.6
50.0	68.6	50.9	14.3	67.1	53.4	13.4	65.5	56.1	12.5	63.8	58.9	11.7	62.0	62.0	10.8

MODEL: YCAL0066EE													IPLV = 15.1		
AIR TEMPERATURE ON CONDENSER (°F)															
LCWT (°F)	75.0			80.0			85.0			90.0			95.0		
	TONS	KW	EER	TONS	KW	EER	TONS	KW	EER	TONS	KW	EER	TONS	KW	EER
40.0	68.6	58.0	12.7	67.0	60.8	11.9	65.3	63.9	11.1	63.5	67.2	10.3	61.7	70.8	9.5
42.0	71.0	58.6	13.1	69.3	61.5	12.2	67.6	64.5	11.4	65.8	67.9	10.6	63.9	71.4	9.8
44.0	73.5	59.2	13.4	71.7	62.1	12.5	69.9	65.2	11.7	68.1	68.5	10.9	66.1	72.1	10.1
45.0	74.7	59.6	13.5	73.0	62.4	12.7	71.1	65.6	11.8	69.2	68.9	11.0	67.3	72.5	10.2
46.0	76.0	59.9	13.7	74.2	62.8	12.8	72.3	65.9	11.9	70.4	69.2	11.1	68.4	72.8	10.3
48.0	78.6	60.6	14.0	76.7	63.5	13.1	74.8	66.6	12.2	72.8	70.0	11.4	70.8	73.6	10.6
50.0	81.1	61.3	14.3	79.2	64.2	13.4	77.3	67.4	12.5	75.2	70.8	11.7	73.1	74.3	10.8

NOTES:

1. kW = Compressor Input Power
2. EER = Chiller EER (includes power from compressors, fans, and the control panels 0.8 kW)
3. LCWT = Leaving Chilled Water Temperature
4. Ratings are based upon 2.4 GPM cooler water per ton and 0.0001 fouling factor
5. Rated in accordance with the latest version of ARI Standard 550/590
6. The shaded points are certified in accordance with the latest version of ARI Standard 550/590

MODEL: YCAL0052EE																	IPLV= 15.1		
AIR TEMPERATURE ON CONDENSER (°F)																			
LCWT (°F)	100.0			105.0			110.0			115.0			120.0			125.0			
	TONS	KW	EER	TONS	KW	EER	TONS	KW	EER	TONS	KW	EER	TONS	KW	EER	TONS	KW	EER	
40.0	41.9	49.9	8.9	40.5	52.8	8.2	39.1	55.8	7.5	37.6	59.1	6.9	36.1	62.5	6.3	18.5	30.1	6.0	
42.0	43.4	50.3	9.1	42.0	53.1	8.4	40.5	56.2	7.7	39.0	59.4	7.1	37.4	62.9	6.4	19.3	30.2	6.3	
44.0	44.9	50.6	9.4	43.5	53.5	8.7	42.0	56.5	8.0	40.4	59.8	7.3	38.7	63.2	6.6	20.0	30.4	6.5	
45.0	45.6	50.8	9.5	44.2	53.7	8.8	42.7	56.7	8.1	41.1	60.0	7.4	39.4	63.4	6.7	20.4	30.4	6.6	
46.0	46.4	51.0	9.7	45.0	53.8	8.9	43.4	56.9	8.2	41.8	60.1	7.5	40.1	63.6	6.8	20.8	30.5	6.7	
48.0	48.0	51.3	9.9	46.5	54.2	9.2	44.9	57.3	8.4	43.3	60.5	7.7	41.5	64.0	7.0	21.5	30.6	6.9	
50.0	49.6	51.7	10.2	48.1	54.6	9.4	46.5	57.7	8.7	44.7	60.9	7.9	42.9	64.4	7.2	22.3	30.7	7.2	

MODEL: YCAL0056EE																	IPLV= 14.7		
AIR TEMPERATURE ON CONDENSER (°F)																			
LCWT (°F)	100.0			105.0			110.0			115.0			120.0			125.0			
	TONS	KW	EER	TONS	KW	EER	TONS	KW	EER	TONS	KW	EER	TONS	KW	EER	TONS	KW	EER	
40.0	50.8	62.6	8.8	49.1	66.1	8.1	47.3	69.8	7.4	45.4	73.8	6.8	43.5	78.0	6.2	22.7	37.0	6.2	
42.0	52.6	63.1	9.0	50.9	66.6	8.3	49.0	70.3	7.6	47.1	74.3	7.0	45.1	78.5	6.3	23.6	37.1	6.5	
44.0	54.5	63.6	9.3	52.6	67.1	8.6	50.7	70.8	7.8	48.7	74.8	7.2	25.6	35.3	7.3	24.5	37.3	6.7	
45.0	55.4	63.9	9.4	53.5	67.4	8.7	51.6	71.1	8.0	49.6	75.1	7.3	26.1	35.4	7.4	25.0	37.4	6.8	
46.0	56.3	64.1	9.5	54.4	67.6	8.8	52.5	71.4	8.1	50.4	75.3	7.4	26.5	35.5	7.5	25.4	37.5	6.9	
48.0	58.2	64.7	9.8	56.3	68.2	9.0	54.3	71.9	8.3	52.2	75.9	7.6	27.5	35.7	7.8	26.4	37.7	7.1	
50.0	60.1	65.3	10.0	58.1	68.8	9.2	56.1	72.5	8.5	53.9	76.5	7.8	28.5	35.9	8.0	27.4	37.9	7.4	

MODEL: YCAL0066EE																	IPLV= 15.1		
AIR TEMPERATURE ON CONDENSER (°F)																			
LCWT (°F)	100.0			105.0			110.0			115.0			120.0			125.0			
	TONS	KW	EER	TONS	KW	EER	TONS	KW	EER	TONS	KW	EER	TONS	KW	EER	TONS	KW	EER	
40.0	59.8	74.7	8.8	57.8	78.8	8.1	55.8	83.3	7.4	53.8	88.2	6.8	51.6	93.5	6.2	26.6	44.3	6.3	
42.0	61.9	75.3	9.1	59.9	79.5	8.3	57.9	84.0	7.7	55.7	88.8	7.0	40.1	63.8	6.8	27.7	44.5	6.5	
44.0	64.1	76.0	9.3	62.1	80.2	8.6	59.9	84.6	7.9	57.7	89.5	7.2	30.0	42.2	7.3	28.8	44.7	6.7	
45.0	65.2	76.3	9.4	63.1	80.5	8.7	61.0	85.0	8.0	58.8	89.8	7.3	30.5	42.4	7.5	29.3	44.8	6.8	
46.0	66.4	76.7	9.5	64.2	80.9	8.8	62.0	85.4	8.1	59.8	90.2	7.4	31.1	42.5	7.6	29.9	44.9	6.9	
48.0	68.6	77.5	9.8	66.5	81.6	9.0	64.2	86.1	8.3	61.9	90.9	7.6	32.3	42.8	7.8	31.0	45.2	7.2	
50.0	71.0	78.2	10.0	68.7	82.4	9.3	66.4	86.9	8.5	64.0	91.7	7.8	33.5	43.0	8.1	32.2	45.5	7.4	

NOTES:

1. kW = Compressor Input Power
2. EER = Chiller EER (includes power from compressors, fans, and the control panels 0.8 kW)
3. LCWT = Leaving Chilled Water Temperature
4. Ratings are based upon 2.4 GPM cooler water per ton and 0.0001 fouling factor
5. Rated in accordance with the latest version of ARI Standard 550/590
6. The shaded points are certified in accordance with the latest version of ARI Standard 550/590

Ratings - R-410A (60Hz - SI Units)

MODEL: YCAL0019EE

AIR TEMPERATURE ON CONDENSER (°C)

LCWT (°C)	25.0			30.0			35.0			40.0			45.0			50.0		
	KW	KW	COP	KW	KW	COP	KW	KW	COP	KW	KW	COP	KW	KW	COP	KW	KW	COP
5.0	57.3	14.0	3.8	54.6	15.6	3.3	51.7	17.4	2.8	48.6	19.4	2.4	45.2	21.7	2.0	23.2	10.5	2.0
6.0	59.0	14.1	3.9	56.2	15.7	3.4	53.2	17.5	2.9	50.1	19.5	2.4	46.6	21.8	2.0	24.0	10.5	2.1
7.0	60.7	14.2	4.0	57.9	15.8	3.4	54.8	17.6	3.0	51.6	19.7	2.5	48.1	21.9	2.1	24.8	10.5	2.2
8.0	62.5	14.3	4.1	59.6	15.9	3.5	56.5	17.7	3.0	53.1	19.8	2.6	49.6	22.0	2.2	25.6	10.5	2.2
9.0	64.3	14.5	4.2	61.3	16.1	3.6	58.1	17.9	3.1	54.7	19.9	2.6	51.1	22.2	2.2	26.4	10.6	2.3
10.0	66.2	14.6	4.2	63.1	16.2	3.7	59.8	18.0	3.2	56.3	20.0	2.7	52.6	22.3	2.3	27.3	10.6	2.4
11.0	68.0	14.7	4.3	64.9	16.3	3.7	61.5	18.1	3.2	58.0	20.2	2.7	54.2	22.4	2.3	28.2	10.6	2.4

MODEL: YCAL0022EE

AIR TEMPERATURE ON CONDENSER (°C)

LCWT (°C)	25.0			30.0			35.0			40.0			45.0			50.0		
	KW	KW	COP	KW	KW	COP	KW	KW	COP	KW	KW	COP	KW	KW	COP	KW	KW	COP
5.0	70.4	17.1	3.9	66.6	19.0	3.3	62.5	21.2	2.8	58.1	23.7	2.4	53.6	26.5	2.0	27.7	12.6	2.0
6.0	72.5	17.3	4.0	68.6	19.2	3.4	64.5	21.4	2.9	60.0	23.8	2.4	55.3	26.6	2.0	28.7	12.6	2.1
7.0	74.6	17.4	4.0	70.7	19.3	3.5	66.4	21.5	3.0	61.9	24.0	2.5	57.1	26.8	2.1	29.7	12.7	2.2
8.0	76.7	17.6	4.1	72.8	19.5	3.6	68.4	21.7	3.0	63.8	24.2	2.5	58.9	26.9	2.1	30.7	12.7	2.2
9.0	78.9	17.8	4.2	74.8	19.7	3.6	70.4	21.9	3.1	65.7	24.4	2.6	60.4	27.0	2.1	31.7	12.7	2.3
10.0	81.1	17.9	4.3	77.0	19.9	3.7	72.5	22.1	3.1	67.7	24.6	2.7	62.5	27.1	2.1	32.8	12.8	2.4
11.0	83.3	18.1	4.4	79.1	20.1	3.8	74.6	22.3	3.2	69.7	24.8	2.7	64.6	27.2	2.1	33.8	12.8	2.5

MODEL: YCAL0028EE

AIR TEMPERATURE ON CONDENSER (°C)

LCWT (°C)	25.0			30.0			35.0			40.0			45.0			50.0		
	KW	KW	COP	KW	KW	COP	KW	KW	COP	KW	KW	COP	KW	KW	COP	KW	KW	COP
5.0	94.0	22.5	3.7	89.9	24.7	3.3	85.5	27.2	2.8	80.7	29.9	2.5	75.6	33.1	2.1	69.9	36.6	1.8
6.0	96.9	22.7	3.8	92.7	24.9	3.3	88.1	27.3	2.9	83.2	30.1	2.5	77.9	33.3	2.2	72.2	36.8	1.8
7.0	99.8	22.9	3.9	95.5	25.1	3.4	90.8	27.5	3.0	85.8	30.3	2.6	80.4	33.4	2.2	74.5	36.9	1.9
8.0	102.8	23.1	3.9	98.3	25.3	3.5	93.6	27.7	3.0	88.4	30.5	2.6	82.8	33.6	2.3	76.8	37.1	1.9
9.0	105.8	23.3	4.0	101.2	25.5	3.6	96.3	27.9	3.1	91.0	30.7	2.7	85.3	33.9	2.3	79.1	37.3	2.0
10.0	108.9	23.5	4.1	104.2	25.7	3.6	99.1	28.2	3.2	93.7	30.9	2.8	87.9	34.1	2.4	81.4	37.5	2.1
11.0	112.0	23.8	4.2	107.2	25.9	3.7	102.0	28.4	3.3	96.4	31.2	2.8	90.5	34.3	2.4	84.7	37.7	2.2

NOTES:

1. kW = Compressor Input Power
2. EER = Chiller EER (includes power from compressors, fans, and the control panels 0.8 kW)
3. LCWT = Leaving Chilled Water Temperature
4. Ratings are based upon 2.4 GPM cooler water per ton and 0.0001 fouling factor
5. Rated in accordance with the latest version of ARI Standard 550/590
6. The shaded points are certified in accordance with the latest version of ARI Standard 550/590

MODEL: YCAL0033EE**AIR TEMPERATURE ON CONDENSER (°C)**

LCWT (°C)	25.0			30.0			35.0			40.0			45.0			50.0		
	KW	KW	COP	KW	KW	COP	KW	KW	COP	KW	KW	COP	KW	KW	COP	KW	KW	COP
5.0	105.1	24.3	3.8	100.6	26.6	3.4	95.6	29.3	3.0	90.1	32.2	2.6	84.2	35.6	2.2	42.7	17.7	2.1
6.0	108.3	24.6	3.9	103.6	26.9	3.5	98.5	29.5	3.0	92.9	32.5	2.6	86.9	35.8	2.2	44.2	17.8	2.1
7.0	111.5	24.8	4.0	106.7	27.1	3.6	101.4	29.7	3.1	95.7	32.7	2.7	89.6	36.0	2.3	45.6	17.9	2.2
8.0	114.7	25.0	4.1	109.8	27.3	3.6	104.4	30.0	3.2	98.6	32.9	2.7	92.3	36.2	2.4	47.1	18.0	2.3
9.0	118.0	25.3	4.2	113.0	27.6	3.7	107.5	30.2	3.2	101.5	33.2	2.8	95.0	36.5	2.4	48.6	18.0	2.3
10.0	121.3	25.5	4.3	116.2	27.8	3.8	110.5	30.5	3.3	104.4	33.4	2.9	97.8	36.7	2.5	50.2	18.1	2.4
11.0	124.7	25.8	4.3	119.4	28.1	3.8	113.7	30.7	3.4	107.4	33.7	2.9	100.7	37.0	2.5	51.8	18.2	2.4

MODEL: YCAL0043EE**AIR TEMPERATURE ON CONDENSER (°C)**

LCWT (°C)	25.0			30.0			35.0			40.0			45.0			50.0		
	KW	KW	COP	KW	KW	COP	KW	KW	COP	KW	KW	COP	KW	KW	COP	KW	KW	COP
5.0	137.1	31.5	3.7	131.0	34.6	3.3	124.1	38.5	2.8	116.4	43.1	2.4	108.1	48.4	2.0	99.1	54.5	1.7
6.0	141.3	31.6	3.8	135.2	34.8	3.4	128.2	38.7	2.9	120.4	43.3	2.5	112.0	48.6	2.1	102.8	54.6	1.7
7.0	145.6	31.8	3.9	139.5	35.0	3.4	132.4	38.9	3.0	124.5	43.5	2.5	115.9	48.7	2.1	106.6	54.7	1.8
8.0	150.0	32.0	4.0	143.8	35.2	3.5	136.6	39.1	3.1	128.6	43.7	2.6	119.8	48.9	2.2	110.4	54.9	1.8
9.0	154.5	32.2	4.1	148.2	35.4	3.6	141.0	39.3	3.1	132.8	43.9	2.7	123.9	49.1	2.3	114.2	55.0	1.9
10.0	159.0	32.4	4.2	152.7	35.6	3.7	145.4	39.5	3.2	137.1	44.1	2.8	128.0	49.3	2.3	118.1	55.2	1.9
11.0	163.6	32.6	4.3	157.2	35.8	3.8	149.8	39.7	3.3	141.4	44.3	2.8	132.1	49.5	2.4	122.1	55.4	2.0

MODEL: YCAL0046EE**AIR TEMPERATURE ON CONDENSER (°C)**

LCWT (°C)	25.0			30.0			35.0			40.0			45.0			50.0		
	KW	KW	COP	KW	KW	COP	KW	KW	COP	KW	KW	COP	KW	KW	COP	KW	KW	COP
5.0	145.4	33.2	3.8	138.7	36.6	3.3	131.4	40.6	2.8	123.4	45.3	2.4	114.7	50.6	2.0	105.4	56.5	1.7
6.0	149.9	33.4	3.8	143.2	36.8	3.4	135.8	40.9	2.9	127.6	45.5	2.5	118.8	50.7	2.1	109.3	56.7	1.8
7.0	154.5	33.6	3.9	147.7	37.1	3.5	140.1	41.1	3.0	131.9	45.7	2.6	122.9	51.0	2.2	113.2	56.9	1.8
8.0	159.3	33.9	4.0	152.3	37.3	3.6	144.6	41.3	3.1	136.2	45.9	2.6	127.1	51.2	2.2	117.2	57.1	1.9
9.0	164.0	34.1	4.1	157.0	37.5	3.6	149.1	41.6	3.2	140.6	46.2	2.7	131.3	51.4	2.3	121.7	57.3	2.0
10.0	168.9	34.3	4.2	161.7	37.8	3.7	153.7	41.8	3.2	145.0	46.4	2.8	135.6	51.6	2.4	126.2	57.5	2.1
11.0	173.8	34.6	4.3	166.5	38.0	3.8	158.4	42.1	3.3	149.5	46.7	2.9	139.9	51.9	2.4	130.7	57.7	2.1

NOTES:

1. kW = Compressor Input Power
2. EER = Chiller EER (includes power from compressors, fans, and the control panels 0.8 kW)
3. LCWT = Leaving Chilled Water Temperature
4. Ratings are based upon 2.4 GPM cooler water per ton and 0.0001 fouling factor
5. Rated in accordance with the latest version of ARI Standard 550/590
6. The shaded points are certified in accordance with the latest version of ARI Standard 550/590

Ratings - R-410A (60Hz - SI Units) - continued

MODEL: YCAL0052EE

AIR TEMPERATURE ON CONDENSER (°C)

LCWT (°C)	25.0			30.0			35.0			40.0			45.0			50.0		
	KW	KW	COP	KW	KW	COP	KW	KW	COP	KW	KW	COP	KW	KW	COP	KW	KW	COP
5.0	169.2	39.0	3.7	162.0	42.9	3.3	154.3	47.4	2.9	146.0	52.4	2.5	136.9	57.9	2.1	126.8	64.1	1.8
6.0	174.6	39.3	3.8	167.2	43.2	3.4	159.2	47.7	2.9	150.7	52.7	2.5	141.3	58.2	2.2	131.0	64.4	1.8
7.0	180.1	39.6	3.9	172.4	43.6	3.4	164.2	48.0	3.0	155.4	53.0	2.6	145.8	58.6	2.2	135.2	64.8	1.9
8.0	185.7	39.9	4.0	177.8	43.9	3.5	169.3	48.3	3.1	160.2	53.3	2.7	150.4	58.9	2.3	139.5	65.1	1.9
9.0	191.5	40.3	4.1	183.3	44.2	3.6	174.5	48.7	3.2	165.2	53.7	2.7	155.0	59.2	2.4	143.9	65.4	2.0
10.0	197.3	40.6	4.2	188.8	44.6	3.7	179.8	49.0	3.2	170.2	54.0	2.8	159.8	59.6	2.4	148.3	65.8	2.1
11.0	203.3	41.0	4.3	194.5	44.9	3.8	185.3	49.4	3.3	175.3	54.4	2.9	164.6	59.9	2.5	143.2	66.2	2.2

MODEL: YCAL0056EE

AIR TEMPERATURE ON CONDENSER (°C)

LCWT (°C)	25.0			30.0			35.0			40.0			45.0			50.0		
	KW	KW	COP	KW	KW	COP	KW	KW	COP	KW	KW	COP	KW	KW	COP	KW	KW	COP
5.0	206.4	49.4	3.7	197.6	54.1	3.3	187.8	59.5	2.8	177.0	65.6	2.5	165.4	72.4	2.1	153.6	80.8	1.9
6.0	212.8	49.9	3.8	203.7	54.6	3.3	193.7	60.0	2.9	182.6	66.1	2.5	170.6	72.9	2.1	159.5	81.3	1.9
7.0	219.3	50.3	3.8	210.0	55.1	3.4	199.6	60.5	3.0	188.3	66.5	2.6	176.0	73.3	2.2	165.8	81.7	2.0
8.0	225.8	50.8	3.9	216.3	55.6	3.5	205.7	61.0	3.0	194.1	67.0	2.6	181.5	73.8	2.3	171.3	82.2	2.0
9.0	232.5	51.3	4.0	222.7	56.1	3.6	211.8	61.5	3.1	199.9	67.5	2.7	187.0	74.3	2.3	177.0	82.7	2.1
10.0	239.2	51.9	4.1	229.2	56.6	3.6	218.1	62.0	3.2	205.9	68.1	2.8	192.6	74.9	2.4	182.6	83.2	2.1
11.0	246.1	52.4	4.2	235.8	57.2	3.7	224.4	62.6	3.2	211.9	68.6	2.8	198.3	75.4	2.4	188.3	83.7	2.2

MODEL: YCAL0066EE

AIR TEMPERATURE ON CONDENSER (°C)

LCWT (°C)	25.0			30.0			35.0			40.0			45.0			50.0		
	KW	KW	COP	KW	KW	COP	KW	KW	COP	KW	KW	COP	KW	KW	COP	KW	KW	COP
5.0	243.2	59.4	3.7	232.3	64.9	3.2	220.7	71.1	2.8	208.4	78.3	2.5	195.5	86.5	2.1	182.6	94.7	1.9
6.0	250.8	60.0	3.8	239.6	65.5	3.3	227.7	71.7	2.9	215.2	78.9	2.5	201.9	87.1	2.2	189.1	95.3	1.9
7.0	258.6	60.6	3.8	247.1	66.1	3.4	234.9	72.3	3.0	222.0	79.5	2.6	208.3	87.7	2.2	196.6	95.9	2.0
8.0	266.5	61.2	3.9	254.7	66.7	3.5	242.2	73.0	3.0	228.9	80.2	2.6	214.9	88.4	2.3	203.2	96.5	2.0
9.0	274.5	61.8	4.0	262.4	67.4	3.5	249.6	73.6	3.1	236.0	80.8	2.7	221.7	89.0	2.3	210.0	97.1	2.1
10.0	282.7	62.4	4.1	270.3	68.0	3.6	257.2	74.3	3.2	243.2	81.5	2.8	228.5	89.7	2.4	216.8	97.7	2.1
11.0	291.0	63.1	4.2	278.3	68.7	3.7	264.8	75.1	3.2	250.5	82.3	2.8	235.4	90.4	2.4	223.6	98.3	2.2

NOTES:

1. kW = Compressor Input Power
2. EER = Chiller EER (includes power from compressors, fans, and the control panels 0.8 kW)
3. LCWT = Leaving Chilled Water Temperature
4. Ratings are based upon 2.4 GPM cooler water per ton and 0.0001 fouling factor
5. Rated in accordance with the latest version of ARI Standard 550/590
6. The shaded points are certified in accordance with the latest version of ARI Standard 550/590

INTENTIONALLY LEFT BLANK

Ratings - R-410A (50Hz - English Units)

MODEL: YCAL0019EE **IPLV = 15.5**
AIR TEMPERATURE ON CONDENSER (°F)

LCWT (°F)	75.0			80.0			85.0			90.0			95.0		
	TONS	KW	EER	TONS	KW	EER	TONS	KW	EER	TONS	KW	EER	TONS	KW	EER
40.0	13.7	11.0	14.2	13.3	11.6	13.1	12.9	12.3	12.0	12.5	13.1	11.0	12.1	13.9	10.0
42.0	14.1	11.1	14.6	13.7	11.7	13.4	13.4	12.4	12.3	13.0	13.2	11.3	12.5	14.0	10.3
44.0	14.6	11.2	14.9	14.2	11.8	13.7	13.8	12.6	12.6	13.4	13.3	11.6	13.0	14.2	10.6
45.0	14.8	11.2	15.1	14.4	11.9	13.9	14.0	12.6	12.8	13.6	13.4	11.7	13.2	14.2	10.7
46.0	15.1	11.3	15.2	14.7	12.0	14.0	14.3	12.7	12.9	13.8	13.4	11.8	13.4	14.3	10.8
48.0	15.6	11.4	15.6	15.1	12.1	14.3	14.7	12.8	13.2	14.3	13.6	12.1	13.8	14.4	11.1
50.0	16.0	11.5	15.9	15.6	12.2	14.6	15.2	12.9	13.5	14.7	13.7	12.4	14.3	14.5	11.3

MODEL: YCAL0022EE **IPLV = 17.1**
AIR TEMPERATURE ON CONDENSER (°F)

LCWT (°F)	75.0			80.0			85.0			90.0			95.0		
	TONS	KW	EER	TONS	KW	EER	TONS	KW	EER	TONS	KW	EER	TONS	KW	EER
40.0	16.7	13.5	14.2	16.2	14.3	13.0	15.7	15.3	11.9	15.2	16.3	10.8	14.6	17.3	9.8
42.0	17.2	13.6	14.6	16.8	14.5	13.3	16.2	15.4	12.2	15.7	16.4	11.1	15.1	17.5	10.1
44.0	17.8	13.8	14.9	17.3	14.6	13.7	16.8	15.6	12.5	16.2	16.5	11.4	15.6	17.6	10.3
45.0	18.1	13.8	15.1	17.6	14.7	13.8	17.1	15.6	12.6	16.5	16.6	11.5	15.9	17.7	10.5
46.0	18.4	13.9	15.2	17.9	14.8	14.0	17.3	15.7	12.8	16.8	16.7	11.6	16.2	17.8	10.6
48.0	19.0	14.0	15.6	18.4	14.9	14.3	17.9	15.8	13.1	17.3	16.8	11.9	16.7	17.9	10.8
50.0	19.6	14.2	15.9	19.0	15.1	14.6	18.5	16.0	13.4	17.9	17.0	12.2	17.2	18.1	11.1

MODEL: YCAL0028EE **IPLV = 14.7**
AIR TEMPERATURE ON CONDENSER (°F)

LCWT (°F)	75.0			80.0			85.0			90.0			95.0		
	TONS	KW	EER	TONS	KW	EER	TONS	KW	EER	TONS	KW	EER	TONS	KW	EER
40.0	22.1	17.3	14.0	21.6	18.3	13.0	21.1	19.3	12.0	20.6	20.5	11.1	20.0	21.8	10.2
42.0	22.9	17.4	14.4	22.4	18.4	13.3	21.8	19.5	12.4	21.3	20.6	11.4	20.7	21.9	10.5
44.0	23.6	17.5	14.7	23.1	18.5	13.7	22.6	19.6	12.7	22.0	20.8	11.7	21.4	22.0	10.8
45.0	24.0	17.6	14.9	23.5	18.6	13.9	23.0	19.7	12.9	22.4	20.8	11.9	21.8	22.1	11.0
46.0	24.4	17.7	15.1	23.9	18.7	14.1	23.3	19.7	13.1	22.8	20.9	12.1	22.1	22.1	11.1
48.0	25.2	17.8	15.5	24.7	18.8	14.4	24.1	19.9	13.4	23.5	21.0	12.4	22.9	22.3	11.4
50.0	26.0	18.0	15.8	25.5	19.0	14.8	24.9	20.0	13.7	24.3	21.2	12.7	23.6	22.4	11.7

NOTES:

1. kW = Compressor Input Power
2. EER = Chiller EER (includes power from compressors, fans, and the control panels 0.8 kW)
3. LCWT = Leaving Chilled Water Temperature
4. Ratings are based upon 2.4 GPM cooler water per ton and 0.0001 fouling factor
5. Rated in accordance with the latest version of ARI Standard 550/590
6. The shaded points are certified in accordance with the latest version of ARI Standard 550/590

MODEL: YCAL0019EE **IPLV = 15.5****AIR TEMPERATURE ON CONDENSER (°F)**

LCWT (°F)	100.0			105.0			110.0			115.0			120.0			125.0		
	TONS	KW	EER	TONS	KW	EER	TONS	KW	EER	TONS	KW	EER	TONS	KW	EER	TONS	KW	EER
40.0	11.7	14.8	9.1	11.3	15.8	8.2	10.8	16.9	7.4	10.3	18.0	6.7	5.4	8.3	7.4	5.2	8.9	6.6
42.0	12.1	14.9	9.4	11.7	15.9	8.5	11.2	17.0	7.7	10.7	18.1	6.9	5.7	8.3	7.6	5.4	8.9	6.9
44.0	12.5	15.1	9.6	12.1	16.0	8.7	11.6	17.1	7.9	11.1	18.2	7.1	5.9	8.3	7.9	5.6	8.9	7.1
45.0	12.7	15.1	9.7	12.3	16.1	8.8	11.8	17.1	8.0	11.3	18.3	7.2	6.0	8.4	8.0	5.7	8.9	7.2
46.0	13.0	15.2	9.9	12.5	16.2	9.0	12.0	17.2	8.1	11.5	18.3	7.3	6.1	8.4	8.2	5.8	8.9	7.4
48.0	13.4	15.3	10.1	12.9	16.3	9.2	12.4	17.3	8.3	11.9	18.4	7.5	6.3	8.4	8.4	6.1	9.0	7.6
50.0	13.8	15.4	10.4	13.3	16.4	9.4	12.8	17.4	8.5	12.3	18.6	7.7	6.5	8.4	8.7	6.3	9.0	7.9

MODEL: YCAL0022EE **IPLV = 17.1****AIR TEMPERATURE ON CONDENSER (°F)**

LCWT (°F)	100.0			105.0			110.0			115.0			120.0			125.0		
	TONS	KW	EER	TONS	KW	EER	TONS	KW	EER	TONS	KW	EER	TONS	KW	EER	TONS	KW	EER
40.0	14.1	18.5	8.9	13.5	19.7	8.0	12.9	21.0	7.2	12.2	22.4	6.4	6.5	10.1	7.3	6.2	10.8	6.5
42.0	14.6	18.6	9.1	13.9	19.8	8.2	13.3	21.1	7.4	12.7	22.5	6.6	6.8	10.1	7.6	6.5	10.8	6.8
44.0	15.1	18.7	9.3	14.4	20.0	8.4	13.8	21.3	7.6	13.1	22.6	6.8	7.1	10.2	7.9	6.7	10.9	7.0
45.0	15.3	18.8	9.5	14.7	20.0	8.5	14.0	21.3	7.7	7.5	9.5	8.9	7.2	10.2	8.0	6.8	10.9	7.2
46.0	15.6	18.9	9.6	14.9	20.1	8.7	14.3	21.4	7.8	7.7	9.6	9.1	7.3	10.2	8.1	7.0	10.9	7.3
48.0	16.1	19.0	9.8	15.4	20.3	8.9	14.8	21.6	8.0	7.9	9.6	9.4	7.6	10.2	8.4	7.2	10.9	7.5
50.0	16.6	19.2	10.1	16.0	20.4	9.1	15.3	21.7	8.2	8.2	9.6	9.7	7.9	10.3	8.7	7.5	11.0	7.8

MODEL: YCAL0028EE **IPLV = 14.7****AIR TEMPERATURE ON CONDENSER (°F)**

LCWT (°F)	100.0			105.0			110.0			115.0			120.0			125.0		
	TONS	KW	EER	TONS	KW	EER	TONS	KW	EER	TONS	KW	EER	TONS	KW	EER	TONS	KW	EER
40.0	19.4	23.1	9.4	18.8	24.6	8.6	18.1	26.1	7.8	17.4	27.7	7.1	16.7	29.4	6.5	9.2	15.4	6.5
42.0	20.1	23.2	9.6	19.4	24.7	8.8	18.8	26.2	8.1	18.1	27.8	7.3	17.3	29.5	6.7	9.6	15.4	6.7
44.0	20.8	23.4	9.9	20.1	24.8	9.1	19.4	26.3	8.3	18.7	28.0	7.6	18.0	29.7	6.9	9.9	15.5	6.9
45.0	21.1	23.4	10.1	20.5	24.9	9.2	19.8	26.4	8.4	19.0	28.0	7.7	18.3	29.8	7.0	10.1	15.5	7.0
46.0	21.5	23.5	10.2	20.8	24.9	9.4	20.1	26.5	8.6	19.4	28.1	7.8	18.6	29.8	7.1	10.3	15.5	7.2
48.0	22.2	23.6	10.5	21.5	25.1	9.6	20.8	26.6	8.8	20.0	28.3	8.0	19.3	30.0	7.3	10.7	15.6	7.4
50.0	22.9	23.8	10.8	22.2	25.2	9.9	21.5	26.8	9.1	20.7	28.4	8.3	19.9	30.2	7.5	11.1	15.6	7.6

NOTES:

1. kW = Compressor Input Power
2. EER = Chiller EER (includes power from compressors, fans, and the control panels 0.8 kW)
3. LCWT = Leaving Chilled Water Temperature
4. Ratings are based upon 2.4 GPM cooler water per ton and 0.0001 fouling factor
5. Rated in accordance with the latest version of ARI Standard 550/590
6. The shaded points are certified in accordance with the latest version of ARI Standard 550/590

Ratings - R-410A (50Hz - English Units) - continued

MODEL: YCAL0033EE **IPLV = 15.9**

AIR TEMPERATURE ON CONDENSER (°F)

LCWT (°F)	75.0			80.0			85.0			90.0			95.0		
	TONS	KW	EER	TONS	KW	EER	TONS	KW	EER	TONS	KW	EER	TONS	KW	EER
40.0	24.8	18.8	14.5	24.3	19.9	13.5	23.7	21.0	12.5	23.1	22.3	11.5	22.4	23.7	10.6
42.0	25.7	18.9	14.9	25.1	20.0	13.9	24.5	21.2	12.8	23.9	22.5	11.8	23.2	23.8	10.9
44.0	26.5	19.1	15.3	25.9	20.2	14.2	25.3	21.3	13.2	24.7	22.6	12.2	24.0	24.0	11.2
45.0	27.0	19.2	15.5	26.4	20.2	14.4	25.7	21.4	13.3	25.1	22.7	12.3	24.4	24.1	11.3
46.0	27.4	19.2	15.7	26.8	20.3	14.6	26.2	21.5	13.5	25.5	22.8	12.5	24.8	24.1	11.5
48.0	28.3	19.4	16.0	27.7	20.5	14.9	27.0	21.7	13.9	26.3	22.9	12.8	25.6	24.3	11.8
50.0	29.2	19.6	16.4	28.5	20.7	15.3	27.9	21.8	14.2	27.2	23.1	13.1	26.4	24.5	12.1

MODEL: YCAL0043EE **IPLV = 16.7**

AIR TEMPERATURE ON CONDENSER (°F)

LCWT (°F)	75.0			80.0			85.0			90.0			95.0		
	TONS	KW	EER	TONS	KW	EER	TONS	KW	EER	TONS	KW	EER	TONS	KW	EER
40.0	32.3	24.3	14.1	31.6	25.9	13.0	30.8	27.6	12.0	29.9	29.4	11.0	28.9	31.4	10.0
42.0	33.5	24.4	14.5	32.7	26.0	13.4	31.9	27.7	12.4	31.0	29.6	11.3	30.0	31.5	10.4
44.0	34.6	24.6	14.9	33.9	26.2	13.8	33.0	27.9	12.7	32.1	29.7	11.7	31.2	31.7	10.7
45.0	35.2	24.7	15.1	34.5	26.3	14.0	33.6	27.9	12.9	32.7	29.8	11.9	31.7	31.7	10.9
46.0	35.8	24.8	15.4	35.0	26.3	14.2	34.2	28.0	13.1	33.3	29.8	12.1	32.3	31.8	11.1
48.0	37.0	25.0	15.8	36.2	26.5	14.6	35.4	28.2	13.5	34.4	30.0	12.4	33.4	32.0	11.4
50.0	38.3	25.1	16.2	37.5	26.7	15.0	36.6	28.4	13.9	35.6	30.2	12.8	34.6	32.1	11.7

MODEL: YCAL0046EE **IPLV = 16.8**

AIR TEMPERATURE ON CONDENSER (°F)

LCWT (°F)	75.0			80.0			85.0			90.0			95.0		
	TONS	KW	EER	TONS	KW	EER	TONS	KW	EER	TONS	KW	EER	TONS	KW	EER
40.0	34.2	25.7	14.2	33.4	27.4	13.1	32.5	29.1	12.1	31.6	31.0	11.1	30.6	33.0	10.1
42.0	35.4	25.9	14.6	34.6	27.5	13.5	33.7	29.3	12.4	32.8	31.2	11.4	31.8	33.2	10.5
44.0	36.7	26.1	15.0	35.9	27.7	13.9	34.9	29.4	12.8	34.0	31.3	11.8	32.9	33.3	10.8
45.0	37.4	26.2	15.2	36.5	27.8	14.1	35.6	29.5	13.0	34.6	31.4	12.0	33.5	33.4	11.0
46.0	38.0	26.3	15.5	37.1	27.9	14.3	36.2	29.6	13.2	35.2	31.5	12.2	34.1	33.5	11.1
48.0	39.3	26.5	15.9	38.4	28.1	14.7	37.4	29.8	13.6	36.4	31.7	12.5	35.4	33.7	11.5
50.0	40.6	26.7	16.3	39.7	28.3	15.1	38.7	30.0	14.0	37.7	31.9	12.9	36.6	33.9	11.8

NOTES:

1. kW = Compressor Input Power
2. EER = Chiller EER (includes power from compressors, fans, and the control panels 0.8 kW)
3. LCWT = Leaving Chilled Water Temperature
4. Ratings are based upon 2.4 GPM cooler water per ton and 0.0001 fouling factor
5. Rated in accordance with the latest version of ARI Standard 550/590
6. The shaded points are certified in accordance with the latest version of ARI Standard 550/590

MODEL: YCAL0033EE **IPLV = 15.9****AIR TEMPERATURE ON CONDENSER (°F)**

LCWT (°F)	100.0			105.0			110.0			115.0			120.0			125.0		
	TONS	KW	EER	TONS	KW	EER	TONS	KW	EER	TONS	KW	EER	TONS	KW	EER	TONS	KW	EER
40.0	21.7	25.1	9.7	21.0	26.7	8.9	20.3	28.3	8.1	19.5	30.0	7.4	18.7	31.9	6.7	9.7	15.2	6.9
42.0	22.5	25.3	10.0	21.8	26.9	9.1	21.0	28.5	8.3	20.2	30.2	7.6	19.4	32.0	6.9	10.1	15.2	7.1
44.0	23.3	25.5	10.3	22.5	27.0	9.4	21.7	28.7	8.6	20.9	30.4	7.8	20.1	32.2	7.1	10.4	15.3	7.4
45.0	23.7	25.5	10.4	22.9	27.1	9.5	22.1	28.7	8.7	21.3	30.5	7.9	20.5	32.3	7.2	10.6	15.3	7.5
46.0	24.1	25.6	10.6	23.3	27.2	9.7	22.5	28.8	8.8	21.7	30.6	8.0	20.8	32.4	7.3	10.8	15.3	7.6
48.0	24.9	25.8	10.8	24.1	27.3	9.9	23.3	29.0	9.1	22.4	30.8	8.3	21.5	32.6	7.5	11.2	15.4	7.9
50.0	25.7	26.0	11.1	24.9	27.5	10.2	24.0	29.2	9.3	23.2	31.0	8.5	22.2	32.8	7.7	11.6	15.4	8.1

MODEL: YCAL0043EE **IPLV = 16.7****AIR TEMPERATURE ON CONDENSER (°F)**

LCWT (°F)	100.0			105.0			110.0			115.0			120.0			125.0		
	TONS	KW	EER	TONS	KW	EER	TONS	KW	EER	TONS	KW	EER	TONS	KW	EER	TONS	KW	EER
40.0	27.9	33.5	9.1	26.9	35.8	8.3	25.8	38.3	7.5	24.7	41.0	6.7	23.5	43.9	6.0	22.2	47.1	5.3
42.0	29.0	33.6	9.4	28.0	35.9	8.6	26.8	38.4	7.7	25.7	41.1	7.0	24.4	44.0	6.2	23.2	47.1	5.5
44.0	30.1	33.8	9.8	29.0	36.1	8.9	27.9	38.5	8.0	26.7	41.2	7.2	25.4	44.1	6.5	12.9	21.1	6.4
45.0	30.7	33.8	9.9	29.6	36.1	9.0	28.4	38.6	8.2	27.2	41.2	7.3	26.0	44.1	6.6	13.1	21.1	6.5
46.0	31.3	33.9	10.1	30.2	36.2	9.2	29.0	38.6	8.3	27.8	41.3	7.5	26.5	44.1	6.7	13.4	21.1	6.6
48.0	32.4	34.1	10.4	31.3	36.3	9.5	30.1	38.8	8.6	28.8	41.4	7.7	27.5	44.3	7.0	14.0	21.1	6.9
50.0	33.5	34.2	10.7	32.4	36.5	9.8	31.2	38.9	8.9	29.9	41.5	8.0	28.6	44.4	7.2	14.5	21.2	7.1

MODEL: YCAL0046EE **IPLV = 16.8****AIR TEMPERATURE ON CONDENSER (°F)**

LCWT (°F)	100.0			105.0			110.0			115.0			120.0			125.0		
	TONS	KW	EER	TONS	KW	EER	TONS	KW	EER	TONS	KW	EER	TONS	KW	EER	TONS	KW	EER
40.0	29.6	35.2	9.2	28.5	37.5	8.4	27.3	40.0	7.6	26.1	42.7	6.8	24.9	45.5	6.1	17.8	34.6	5.6
42.0	30.7	35.3	9.6	29.6	37.7	8.7	28.4	40.1	7.9	27.2	42.8	7.1	25.9	45.7	6.4	18.5	34.7	5.9
44.0	31.9	35.5	9.9	30.7	37.8	9.0	29.5	40.3	8.1	28.3	43.0	7.3	27.0	45.8	6.6	13.6	21.9	6.5
45.0	32.5	35.6	10.0	31.3	37.9	9.1	30.1	40.4	8.3	28.8	43.0	7.5	27.5	45.9	6.7	13.9	21.9	6.6
46.0	33.0	35.7	10.2	31.9	38.0	9.3	30.7	40.5	8.4	29.4	43.1	7.6	28.0	46.0	6.8	14.2	21.9	6.8
48.0	34.3	35.9	10.5	33.1	38.2	9.6	31.8	40.7	8.7	30.5	43.3	7.9	29.1	46.2	7.1	14.8	22.0	7.0
50.0	35.5	36.1	10.8	34.3	38.4	9.9	33.0	40.9	9.0	31.7	43.5	8.1	30.2	46.4	7.3	15.4	22.0	7.3

NOTES:

1. kW = Compressor Input Power
2. EER = Chiller EER (includes power from compressors, fans, and the control panels 0.8 kW)
3. LCWT = Leaving Chilled Water Temperature
4. Ratings are based upon 2.4 GPM cooler water per ton and 0.0001 fouling factor
5. Rated in accordance with the latest version of ARI Standard 550/590
6. The shaded points are certified in accordance with the latest version of ARI Standard 550/590

Ratings - R-410A (50Hz - English Units) - continued**MODEL: YCAL0052EE** **IPLV = 16.2****AIR TEMPERATURE ON CONDENSER (°F)**

LCWT (°F)	75.0			80.0			85.0			90.0			95.0		
	TONS	KW	EER	TONS	KW	EER	TONS	KW	EER	TONS	KW	EER	TONS	KW	EER
40.0	39.7	29.8	14.1	38.9	31.6	13.2	38.0	33.5	12.2	37.0	35.5	11.3	36.0	37.7	10.4
42.0	41.1	30.0	14.5	40.2	31.8	13.5	39.3	33.6	12.6	38.4	35.7	11.6	37.3	37.9	10.7
44.0	42.5	30.3	14.9	41.6	32.0	13.9	40.7	33.9	12.9	39.7	35.9	12.0	38.7	38.1	11.1
45.0	43.2	30.4	15.1	42.3	32.1	14.1	41.4	34.0	13.1	40.4	36.0	12.2	39.3	38.2	11.2
46.0	43.9	30.5	15.3	43.0	32.2	14.3	42.1	34.1	13.3	41.1	36.1	12.3	40.0	38.3	11.4
48.0	45.4	30.8	15.7	44.5	32.5	14.7	43.5	34.3	13.7	42.5	36.3	12.7	41.4	38.5	11.7
50.0	46.9	31.1	16.1	46.0	32.7	15.1	45.0	34.6	14.0	43.9	36.6	13.0	42.8	38.8	12.0

MODEL: YCAL0056EE **IPLV = 16.2****AIR TEMPERATURE ON CONDENSER (°F)**

LCWT (°F)	75.0			80.0			85.0			90.0			95.0		
	TONS	KW	EER	TONS	KW	EER	TONS	KW	EER	TONS	KW	EER	TONS	KW	EER
40.0	48.7	38.1	13.9	47.6	40.3	12.9	46.5	42.8	12.0	45.3	45.4	11.0	44.0	48.2	10.2
42.0	50.3	38.4	14.3	49.3	40.6	13.3	48.1	43.1	12.3	46.9	45.7	11.4	45.6	48.5	10.4
44.0	52.1	38.7	14.7	50.9	40.9	13.6	49.8	43.4	12.6	48.5	46.0	11.7	47.2	48.8	10.7
45.0	52.9	38.9	14.9	51.8	41.1	13.8	50.6	43.5	12.8	49.3	46.2	11.8	48.0	49.0	10.9
46.0	53.8	39.0	15.0	52.7	41.3	14.0	51.4	43.7	13.0	50.2	46.3	12.0	48.8	49.1	11.0
48.0	55.6	39.4	15.4	54.4	41.6	14.3	53.2	44.1	13.3	51.8	46.7	12.3	50.4	49.5	11.3
50.0	57.4	39.8	15.8	56.2	42.0	14.7	54.9	44.4	13.6	53.6	47.0	12.6	52.1	49.9	11.6

MODEL: YCAL0066EE **IPLV = 0.0****AIR TEMPERATURE ON CONDENSER (°F)**

LCWT (°F)	75.0			80.0			85.0			90.0			95.0		
	TONS	KW	EER	TONS	KW	EER	TONS	KW	EER	TONS	KW	EER	TONS	KW	EER
40.0	57.7	46.6	13.7	56.3	49.2	12.7	54.9	51.9	11.8	53.4	54.9	10.9	51.8	58.2	10.0
42.0	59.7	47.1	14.1	58.3	49.6	13.1	56.8	52.4	12.1	55.3	55.4	11.2	53.7	58.6	10.3
44.0	61.8	47.5	14.4	60.3	50.1	13.4	58.8	52.8	12.4	57.2	55.8	11.5	0.0	0.0	0.0
45.0	62.8	47.7	14.6	61.3	50.3	13.6	59.8	53.1	12.6	58.2	56.1	11.7	56.6	59.3	10.7
46.0	63.9	48.0	14.8	62.4	50.5	13.8	60.8	53.3	12.8	59.2	56.3	11.8	57.5	59.5	10.9
48.0	66.0	48.5	15.1	64.5	51.0	14.1	62.9	53.8	13.1	61.2	56.8	12.1	59.5	60.0	11.2
50.0	68.2	49.0	15.5	66.6	51.5	14.4	65.0	54.3	13.4	63.3	57.3	12.4	61.5	60.6	11.5

NOTES:

1. kW = Compressor Input Power
2. EER = Chiller EER (includes power from compressors, fans, and the control panels 0.8 kW)
3. LCWT = Leaving Chilled Water Temperature
4. Ratings are based upon 2.4 GPM cooler water per ton and 0.0001 fouling factor
5. Rated in accordance with the latest version of ARI Standard 550/590
6. The shaded points are certified in accordance with the latest version of ARI Standard 550/590

MODEL: YCAL0052EE **IPLV = 16.2**

AIR TEMPERATURE ON CONDENSER (°F)																		
LCWT (°F)	100.0			105.0			110.0			115.0			120.0			125.0		
	TONS	KW	EER	TONS	KW	EER	TONS	KW	EER	TONS	KW	EER	TONS	KW	EER	TONS	KW	EER
40.0	35.0	40.0	9.6	33.9	42.5	8.8	32.7	45.2	8.0	31.5	48.0	7.3	30.2	50.9	6.6	15.4	24.5	6.5
42.0	36.3	40.2	9.9	35.1	42.7	9.0	34.0	45.4	8.3	32.7	48.2	7.5	31.4	51.2	6.8	16.0	24.6	6.7
44.0	37.6	40.4	10.2	36.4	43.0	9.3	35.2	45.6	8.5	33.9	48.5	7.8	32.6	51.4	7.1	16.6	24.6	7.0
45.0	38.2	40.5	10.3	37.0	43.1	9.5	35.8	45.7	8.7	34.5	48.6	7.9	33.2	51.6	7.2	16.9	24.7	7.1
46.0	38.9	40.7	10.5	37.7	43.2	9.6	36.4	45.9	8.8	35.1	48.7	8.0	33.8	51.7	7.3	17.3	24.7	7.2
48.0	40.2	40.9	10.8	39.0	43.4	9.9	37.7	46.1	9.1	36.4	48.9	8.3	35.0	52.0	7.5	17.9	24.8	7.5
50.0	41.6	41.1	11.1	40.3	43.6	10.2	39.0	46.3	9.3	37.7	49.2	8.5	36.2	52.2	7.7	18.6	24.9	7.8

MODEL: YCAL0056EE **IPLV = 16.2**

AIR TEMPERATURE ON CONDENSER (°F)																		
LCWT (°F)	100.0			105.0			110.0			115.0			120.0			125.0		
	TONS	KW	EER	TONS	KW	EER	TONS	KW	EER	TONS	KW	EER	TONS	KW	EER	TONS	KW	EER
40.0	42.7	51.1	9.3	41.3	54.3	8.5	39.9	57.6	7.8	38.3	61.1	7.1	36.7	64.8	6.4	18.9	30.7	6.6
42.0	44.2	51.5	9.6	42.8	54.6	8.8	41.3	58.0	8.0	39.7	61.5	7.3	38.1	65.2	6.6	19.7	30.8	6.8
44.0	45.8	51.8	9.9	44.3	55.0	9.0	42.8	58.4	8.2	41.2	61.9	7.5	39.5	65.6	6.8	20.4	30.9	7.0
45.0	46.6	52.0	10.0	45.1	55.2	9.2	43.5	58.5	8.4	41.9	62.1	7.6	40.2	65.8	6.9	20.8	31.0	7.2
46.0	47.3	52.2	10.1	45.8	55.4	9.3	44.3	58.7	8.5	42.6	62.3	7.7	40.9	66.1	7.0	21.2	31.1	7.3
48.0	49.0	52.5	10.4	47.4	55.7	9.5	45.8	59.1	8.7	44.1	62.7	7.9	22.9	29.4	8.3	22.0	31.2	7.5
50.0	50.6	52.9	10.7	49.0	56.1	9.8	47.3	59.5	9.0	45.6	63.1	8.2	23.8	29.5	8.6	22.8	31.3	7.8

MODEL: YCAL0066EE **IPLV = 0.0**

AIR TEMPERATURE ON CONDENSER (°F)																		
LCWT (°F)	100.0			105.0			110.0			115.0			120.0			125.0		
	TONS	KW	EER	TONS	KW	EER	TONS	KW	EER	TONS	KW	EER	TONS	KW	EER	TONS	KW	EER
40.0	50.2	61.6	9.2	48.6	65.4	8.4	46.9	69.4	7.7	45.1	73.7	7.0	43.3	78.4	6.3	22.2	37.1	6.5
42.0	52.1	62.1	9.5	50.4	65.9	8.7	48.6	69.9	7.9	46.8	74.2	7.2	45.0	78.9	6.5	23.0	37.2	6.7
44.0	53.9	62.6	9.7	52.2	66.3	8.9	50.4	70.4	8.1	48.6	74.7	7.4	34.8	53.5	7.3	24.0	37.4	7.0
45.0	54.9	62.8	9.9	53.1	66.6	9.0	51.3	70.6	8.3	49.5	75.0	7.5	35.5	53.6	7.4	24.4	37.5	7.1
46.0	55.8	63.1	10.0	54.1	66.8	9.2	52.2	70.9	8.4	50.3	75.3	7.6	36.1	53.8	7.5	24.9	37.5	7.2
48.0	57.8	63.6	10.3	55.9	67.4	9.4	54.0	71.4	8.6	52.1	75.8	7.8	37.5	54.1	7.8	25.8	37.7	7.5
50.0	59.7	64.1	10.5	57.8	67.9	9.7	55.9	72.0	8.8	53.9	76.4	8.1	38.9	54.4	8.0	26.8	37.8	7.7

NOTES:

1. kW = Compressor Input Power
2. EER = Chiller EER (includes power from compressors, fans, and the control panels 0.8 kW)
3. LCWT = Leaving Chilled Water Temperature
4. Ratings are based upon 2.4 GPM cooler water per ton and 0.0001 fouling factor
5. Rated in accordance with the latest version of ARI Standard 550/590
6. The shaded points are certified in accordance with the latest version of ARI Standard 550/590

Ratings - R-410A (50Hz - SI Units)

MODEL: YCAL0019EE
AIR TEMPERATURE ON CONDENSER (°C)

LCWT (°C)	25.0			30.0			35.0			40.0			45.0			50.0		
	KW	KW	COP	KW	KW	COP	KW	KW	COP	KW	KW	COP	KW	KW	COP	KW	KW	COP
5.0	48.3	11.3	4.1	45.9	12.5	3.5	43.4	14.0	3.0	40.6	15.7	2.5	37.7	17.6	2.1	19.2	8.5	2.1
6.0	49.8	11.4	4.2	47.3	12.6	3.6	44.7	14.1	3.1	41.9	15.8	2.6	39.0	17.7	2.1	19.8	8.6	2.2
7.0	51.3	11.5	4.3	48.8	12.7	3.7	46.1	14.2	3.1	43.2	15.9	2.6	40.2	17.8	2.2	20.5	8.6	2.2
8.0	52.8	11.6	4.3	50.2	12.9	3.7	47.5	14.3	3.2	44.6	16.0	2.7	41.5	17.9	2.3	21.2	8.6	2.3
9.0	54.3	11.7	4.4	51.6	13.0	3.8	48.8	14.4	3.3	45.9	16.1	2.8	42.8	18.0	2.3	21.9	8.6	2.4
10.0	55.8	11.8	4.5	53.1	13.1	3.9	50.2	14.5	3.3	47.2	16.2	2.8	44.1	18.1	2.4	22.6	8.7	2.5
11.0	57.4	11.9	4.6	54.6	13.2	4.0	51.7	14.7	3.4	48.6	16.3	2.9	45.4	18.2	2.4	23.4	8.7	2.5

MODEL: YCAL0022EE
AIR TEMPERATURE ON CONDENSER (°C)

LCWT (°C)	25.0			30.0			35.0			40.0			45.0			50.0		
	KW	KW	COP	KW	KW	COP	KW	KW	COP	KW	KW	COP	KW	KW	COP	KW	KW	COP
5.0	59.0	13.9	4.1	55.8	15.5	3.5	52.3	17.4	2.9	48.6	19.5	2.4	44.7	21.9	2.0	23.0	10.4	2.1
6.0	60.7	14.0	4.2	57.5	15.7	3.5	53.9	17.5	3.0	50.2	19.6	2.5	46.2	22.0	2.0	23.8	10.4	2.2
7.0	62.5	14.1	4.3	59.2	15.8	3.6	55.6	17.7	3.1	51.7	19.8	2.5	47.6	22.1	2.1	24.6	10.5	2.2
8.0	64.3	14.3	4.3	60.9	15.9	3.7	57.3	17.8	3.1	53.3	19.9	2.6	49.1	22.3	2.2	25.4	10.5	2.3
9.0	66.2	14.4	4.4	62.7	16.1	3.8	58.9	17.9	3.2	54.9	20.0	2.7	50.7	22.4	2.2	26.3	10.5	2.4
10.0	68.0	14.5	4.5	64.5	16.2	3.8	60.7	18.1	3.3	56.6	20.2	2.7	52.2	22.5	2.3	27.2	10.5	2.4
11.0	69.9	14.7	4.6	66.3	16.3	3.9	62.4	18.2	3.3	58.2	20.3	2.8	30.4	9.4	3.0	28.1	10.6	2.5

MODEL: YCAL0028EE
AIR TEMPERATURE ON CONDENSER (°C)

LCWT (°C)	25.0			30.0			35.0			40.0			45.0			50.0		
	KW	KW	COP	KW	KW	COP	KW	KW	COP	KW	KW	COP	KW	KW	COP	KW	KW	COP
5.0	78.4	17.7	4.0	75.2	19.6	3.5	71.5	21.8	3.0	67.6	24.3	2.6	63.4	27.1	2.2	58.8	30.2	1.9
6.0	80.8	17.8	4.1	77.5	19.7	3.6	73.8	21.9	3.1	69.8	24.4	2.7	65.4	27.2	2.3	60.8	30.3	1.9
7.0	83.2	18.0	4.2	79.8	19.8	3.7	76.0	22.1	3.2	71.9	24.6	2.7	67.5	27.3	2.3	62.8	30.4	2.0
8.0	85.7	18.1	4.3	82.2	20.0	3.8	78.3	22.2	3.3	74.2	24.7	2.8	69.6	27.5	2.4	64.8	30.6	2.0
9.0	88.2	18.2	4.4	84.6	20.1	3.9	80.7	22.3	3.4	76.4	24.8	2.9	71.8	27.6	2.5	66.8	30.7	2.1
10.0	90.8	18.4	4.5	87.1	20.2	4.0	83.1	22.4	3.4	78.7	24.9	3.0	74.0	27.7	2.5	68.9	30.9	2.1
11.0	93.4	18.5	4.6	89.6	20.4	4.1	85.5	22.6	3.5	81.0	25.1	3.0	76.2	27.9	2.6	71.1	31.1	2.1

NOTES:

1. kW = Compressor Input Power
2. EER = Chiller EER (includes power from compressors, fans, and the control panels 0.8 kW)
3. LCWT = Leaving Chilled Water Temperature
4. Ratings are based upon 2.4 GPM cooler water per ton and 0.0001 fouling factor
5. Rated in accordance with the latest version of ARI Standard 550/590
6. The shaded points are certified in accordance with the latest version of ARI Standard 550/590

MODEL: YCAL0033EE**AIR TEMPERATURE ON CONDENSER (°C)**

LCWT (°C)	25.0			30.0			35.0			40.0			45.0			50.0		
	KW	KW	COP	KW	KW	COP	KW	KW	COP	KW	KW	COP	KW	KW	COP	KW	KW	COP
5.0	88.1	19.3	4.2	84.3	21.4	3.7	80.2	23.8	3.2	75.8	26.5	2.7	71.0	29.4	2.3	65.9	32.7	1.9
6.0	90.7	19.4	4.3	86.9	21.5	3.7	82.7	23.9	3.2	78.1	26.6	2.8	73.3	29.6	2.3	68.0	32.9	2.0
7.0	93.4	19.5	4.4	89.5	21.6	3.8	85.2	24.0	3.3	80.5	26.7	2.8	75.5	29.8	2.4	68.1	33.0	2.1
8.0	96.1	19.7	4.5	92.1	21.8	3.9	87.7	24.2	3.4	83.0	26.9	2.9	77.9	29.9	2.5	69.4	33.1	2.2
9.0	98.9	19.9	4.6	94.8	21.9	4.0	90.3	24.3	3.5	85.5	27.0	3.0	80.2	30.1	2.5	70.7	33.2	2.3
10.0	101.7	20.0	4.7	97.5	22.1	4.1	93.0	24.5	3.6	88.0	27.2	3.0	82.7	30.2	2.6	71.9	33.3	2.4
11.0	104.6	20.2	4.8	100.3	22.2	4.2	95.6	24.6	3.6	90.6	27.4	3.1	85.1	30.4	2.7	73.3	33.4	2.5

MODEL: YCAL0043EE**AIR TEMPERATURE ON CONDENSER (°C)**

LCWT (°C)	25.0			30.0			35.0			40.0			45.0			50.0		
	KW	KW	COP	KW	KW	COP	KW	KW	COP	KW	KW	COP	KW	KW	COP	KW	KW	COP
5.0	114.7	25.0	4.1	109.5	28.0	3.5	103.7	31.5	3.0	97.2	35.4	2.5	90.1	39.9	2.1	82.5	45.2	1.7
6.0	118.3	25.1	4.2	113.1	28.1	3.6	107.2	31.6	3.1	100.6	35.5	2.6	93.4	40.0	2.2	85.6	45.3	1.8
7.0	122.0	25.3	4.3	116.8	28.3	3.7	110.8	31.7	3.2	104.1	35.6	2.7	96.7	40.1	2.2	88.7	45.4	1.8
8.0	125.8	25.4	4.4	120.4	28.4	3.8	114.4	31.8	3.3	107.6	35.7	2.8	100.1	40.2	2.3	91.9	45.5	1.9
9.0	129.6	25.6	4.5	124.2	28.6	3.9	118.0	32.0	3.4	111.1	35.9	2.8	103.5	40.3	2.4	95.2	45.6	2.0
10.0	133.5	25.8	4.6	128.0	28.7	4.0	121.7	32.1	3.4	114.7	36.0	2.9	107.0	40.5	2.5	98.5	45.7	2.0
11.0	137.4	25.9	4.7	131.9	28.9	4.1	125.5	32.3	3.5	118.3	36.2	3.0	110.5	40.6	2.5	101.9	45.8	2.1

MODEL: YCAL0046EE**AIR TEMPERATURE ON CONDENSER (°C)**

LCWT (°C)	25.0			30.0			35.0			40.0			45.0			50.0		
	KW	KW	COP	KW	KW	COP	KW	KW	COP	KW	KW	COP	KW	KW	COP	KW	KW	COP
5.0	121.3	26.4	4.1	115.7	29.6	3.5	109.6	33.1	3.0	102.9	37.1	2.6	95.5	41.6	2.1	87.4	46.8	1.8
6.0	125.2	26.6	4.2	119.6	29.7	3.6	113.3	33.2	3.1	106.5	37.2	2.6	98.9	41.8	2.2	90.7	46.9	1.8
7.0	129.3	26.8	4.3	123.5	29.9	3.7	117.1	33.4	3.2	110.1	37.4	2.7	102.4	41.9	2.3	94.0	47.1	1.9
8.0	133.3	26.9	4.4	127.4	30.0	3.8	120.9	33.6	3.3	113.8	37.6	2.8	106.0	42.1	2.3	97.4	47.2	1.9
9.0	137.4	27.1	4.5	131.4	30.2	3.9	124.8	33.7	3.4	117.5	37.7	2.9	109.6	42.2	2.4	100.8	47.3	2.0
10.0	141.6	27.3	4.6	135.4	30.4	4.0	128.7	33.9	3.5	121.3	37.9	3.0	113.2	42.4	2.5	104.3	47.4	2.1
11.0	145.8	27.5	4.7	139.6	30.6	4.1	132.7	34.1	3.6	125.1	38.1	3.0	116.9	42.6	2.6	108.5	47.5	2.2

NOTES:

1. kW = Compressor Input Power
2. EER = Chiller EER (includes power from compressors, fans, and the control panels 0.8 kW)
3. LCWT = Leaving Chilled Water Temperature
4. Ratings are based upon 2.4 GPM cooler water per ton and 0.0001 fouling factor
5. Rated in accordance with the latest version of ARI Standard 550/590
6. The shaded points are certified in accordance with the latest version of ARI Standard 550/590

Ratings - R-410A (50Hz - SI Units) - continued

MODEL: YCAL0052EE
AIR TEMPERATURE ON CONDENSER (°C)

LCWT (°C)	25.0			30.0			35.0			40.0			45.0			50.0		
	KW	KW	COP	KW	KW	COP	KW	KW	COP	KW	KW	COP	KW	KW	COP	KW	KW	COP
5.0	140.8	30.6	4.1	135.2	33.9	3.6	129.0	37.8	3.1	122.2	42.1	2.7	114.7	47.0	2.3	106.5	52.3	1.9
6.0	145.2	30.8	4.2	139.5	34.1	3.7	133.2	38.0	3.2	126.1	42.3	2.7	118.5	47.2	2.3	110.2	52.5	2.0
7.0	149.7	31.0	4.3	143.9	34.3	3.8	137.4	38.1	3.3	130.2	42.5	2.8	122.3	47.4	2.4	113.8	52.8	2.0
8.0	154.3	31.2	4.4	148.3	34.5	3.9	141.7	38.3	3.4	134.3	42.7	2.9	126.3	47.6	2.5	117.6	53.0	2.1
9.0	158.9	31.5	4.5	152.9	34.7	4.0	146.0	38.5	3.4	138.5	42.9	3.0	130.3	47.8	2.5	121.4	53.2	2.1
10.0	163.7	31.7	4.6	157.5	34.9	4.1	150.5	38.8	3.5	142.8	43.1	3.0	134.4	48.0	2.6	125.2	53.5	2.2
11.0	168.5	32.0	4.7	162.2	35.2	4.2	155.0	39.0	3.6	147.1	43.3	3.1	138.5	48.3	2.7	129.2	53.7	2.2

MODEL: YCAL0056EE
AIR TEMPERATURE ON CONDENSER (°C)

LCWT (°C)	25.0			30.0			35.0			40.0			45.0			50.0		
	KW	KW	COP	KW	KW	COP	KW	KW	COP	KW	KW	COP	KW	KW	COP	KW	KW	COP
5.0	172.6	39.1	4.0	165.5	43.4	3.5	157.6	48.3	3.0	148.9	53.8	2.6	139.5	59.9	2.2	69.6	29.7	2.1
6.0	177.9	39.4	4.1	170.6	43.7	3.6	162.5	48.6	3.1	153.6	54.1	2.7	144.0	60.2	2.3	72.0	29.8	2.1
7.0	183.3	39.7	4.2	175.9	44.0	3.7	167.6	48.9	3.2	158.5	54.5	2.7	148.6	60.6	2.3	74.5	29.9	2.2
8.0	188.8	40.0	4.3	181.2	44.3	3.8	172.7	49.2	3.3	163.4	54.8	2.8	153.2	60.9	2.4	77.0	30.0	2.3
9.0	194.5	40.3	4.4	186.6	44.6	3.9	177.9	49.5	3.3	168.4	55.1	2.9	158.0	61.3	2.4	79.6	30.1	2.3
10.0	200.2	40.6	4.5	192.2	44.9	3.9	183.3	49.9	3.4	173.5	55.4	2.9	162.8	61.7	2.5	82.3	30.2	2.4
11.0	206.0	41.0	4.6	197.8	45.3	4.0	188.7	50.2	3.5	178.6	55.8	3.0	167.8	62.0	2.6	85.0	30.3	2.5

MODEL: YCAL0066EE
AIR TEMPERATURE ON CONDENSER (°C)

LCWT (°C)	25.0			30.0			35.0			40.0			45.0			50.0		
	KW	KW	COP	KW	KW	COP	KW	KW	COP	KW	KW	COP	KW	KW	COP	KW	KW	COP
5.0	204.4	47.8	4.0	195.3	52.7	3.5	185.6	58.4	3.0	175.2	64.8	2.6	164.2	72.2	2.2	113.8	54.4	2.0
6.0	210.8	48.2	4.1	201.5	53.1	3.5	191.5	58.8	3.1	181.0	65.3	2.6	169.7	72.7	2.2	117.8	54.6	2.0
7.0	217.3	48.6	4.1	207.8	53.5	3.6	197.6	59.2	3.1	186.8	65.7	2.7	175.3	73.1	2.3	121.8	54.9	2.1
8.0	224.0	49.1	4.2	214.2	54.0	3.7	203.7	59.6	3.2	192.6	66.2	2.8	180.9	73.6	2.3	126.0	55.1	2.1
9.0	230.7	49.5	4.3	220.7	54.4	3.8	210.0	60.1	3.3	198.6	66.6	2.8	186.6	74.1	2.4	130.2	55.4	2.2
10.0	237.6	50.0	4.4	227.4	54.9	3.9	216.4	60.6	3.4	204.8	67.1	2.9	192.4	74.6	2.5	134.5	55.7	2.3
11.0	244.6	50.4	4.5	234.2	55.3	4.0	222.9	61.0	3.4	211.0	67.6	3.0	198.4	75.1	2.5	138.9	56.0	2.3

NOTES:

1. kW = Compressor Input Power
2. EER = Chiller EER (includes power from compressors, fans, and the control panels 0.8 kW)
3. LCWT = Leaving Chilled Water Temperature
4. Ratings are based upon 2.4 GPM cooler water per ton and 0.0001 fouling factor
5. Rated in accordance with the latest version of ARI Standard 550/590
6. The shaded points are certified in accordance with the latest version of ARI Standard 550/590

INTENTIONALLY LEFT BLANK

Part Load Ratings - 60 Hz R-410A (English Units)

YCAL0019				
% DISPL.	TONS	KW	AMBIENT (°F)	UNIT EER
100	15.4	17.6	95.0	10.0
50	9.1	6.3	70.2	16.0
IPLV=14.6				

YCAL0022				
% DISPL.	TONS	KW	AMBIENT (°F)	UNIT EER
100	18.7	21.5	95.0	10.0
50	11.5	7.2	72.1	16.9
IPLV=15.5				

YCAL0028				
% DISPL.	TONS	KW	AMBIENT (°F)	UNIT EER
100	25.6	27.5	95.0	10.1
50	15.7	11.7	71.9	14.3
IPLV=13.4				

YCAL0033				
% DISPL.	TONS	KW	AMBIENT (°F)	UNIT EER
100	28.6	29.6	95.0	10.5
50	16.7	11.2	70.0	15.7
IPLV=14.5				

YCAL0043				
% DISPL.	TONS	KW	AMBIENT (°F)	UNIT EER
100	37.2	38.8	95.0	10.1
75	30.0	24.4	83.3	12.0
50	21.1	14.2	69.0	14.9
25	11.5	6.6	55.0	17.3
IPLV=14.5				

YCAL0046				
% DISPL.	TONS	KW	AMBIENT (°F)	UNIT EER
100	39.4	41.0	95.0	10.2
75	31.5	25.2	82.9	12.3
50	22.4	14.9	69.1	15.2
25	11.6	6.5	55.0	17.5
IPLV=14.7				

YCAL0052				
% DISPL.	TONS	KW	AMBIENT (°F)	UNIT EER
100	46.2	47.9	95.0	10.2
75	37.3	30.7	83.4	12.0
50	26.6	17.6	69.5	15.2
25	15.1	7.8	55.0	19.1
IPLV=15.1				

YCAL0056				
% DISPL.	TONS	KW	AMBIENT (°F)	UNIT EER
100	56.2	60.3	95.0	10.1
75	45.5	38.8	83.6	12.0
50	32.2	22.6	69.4	14.9
25	18.0	10.2	55.0	18.1
IPLV=14.7				

YCAL0066				
% DISPL.	TONS	KW	AMBIENT (°F)	UNIT EER
100	66.1	72.1	95.0	10.1
75	52.5	42.2	82.6	12.9
50	37.8	26.6	69.3	15.2
25	18.5	10.3	55.0	18.5
IPLV=15.1				

Part Load Ratings - 50 Hz R-410A (English Units)

YCAL0019				
% DISPL.	TONS	KW	AMBIENT (°F)	UNIT EER
100	13.0	14.2	95.0	10.6
50	7.6	5.1	70.2	17.0
IPLV=15.5				

YCAL0022				
% DISPL.	TONS	KW	AMBIENT (°F)	UNIT EER
100	15.6	17.6	95.0	10.3
50	9.7	5.6	72.0	18.8
IPLV=17.1				

YCAL0028				
% DISPL.	TONS	KW	AMBIENT (°F)	UNIT EER
100	21.4	22.0	95.0	10.8
50	13.1	9.1	71.6	15.8
IPLV=14.7				

YCAL0033				
% DISPL.	TONS	KW	AMBIENT (°F)	UNIT EER
100	24.0	24.0	95.0	11.1
50	13.8	8.7	69.6	17.3
IPLV=15.9				

YCAL0043				
% DISPL.	TONS	KW	AMBIENT (°F)	UNIT EER
100	31.2	31.7	95.0	10.7
75	25.1	19.5	83.3	13.2
50	17.6	10.7	68.8	17.1
25	9.7	4.6	55.0	21.5
IPLV=16.7				

YCAL0046				
% DISPL.	TONS	KW	AMBIENT (°F)	UNIT EER
100	32.9	33.3	95.0	10.8
75	26.2	20.1	82.8	13.5
50	18.6	11.5	68.9	17.0
25	9.7	4.6	55.0	21.7
IPLV=16.8				

YCAL0052				
% DISPL.	TONS	KW	AMBIENT (°F)	UNIT EER
100	38.7	38.1	95.0	11.1
75	31.0	24.0	83.0	13.3
50	21.7	13.7	68.7	16.7
25	12.0	6.3	55.0	19.9
IPLV=16.2				

YCAL0056				
% DISPL.	TONS	KW	AMBIENT (°F)	UNIT EER
100	47.2	48.8	95.0	10.7
75	38.0	30.6	83.3	13.2
50	26.7	17.4	68.9	16.5
25	14.8	7.9	55.0	20.0
IPLV=16.2				

YCAL0066				
% DISPL.	TONS	KW	AMBIENT (°F)	UNIT EER
100	55.6	59.1	95.0	10.6
75	43.9	33.7	82.3	14.0
50	31.2	0	69.0	0
25	15.0	0	55.0	0
IPLV=0				

Physical Data - English & SI

60Hz

Model YCAL00		19	22	28	33	43	46	52	56	66	
Length		109.8	109.8	118.6	118.6	144.8	144.8	148.8	148.8	153.6	
Width		44.7	44.7	44.7	44.7	90.6	90.6	90.6	90.6	90.6	
Height		46.1	46.1	50	50	47.8	47.8	62.6	62.6	62.6	
Nominal Tons		14.5	17.8	24.3	28	34.9	38	45.2	45.2	60.1	
Number of Refrigerant Circuits		1	1	1	1	2	2	2	2	2	
Refrig. Chg, Opt, R-410A (lbs) ckt1/ckt2		25	30	45	50	35/35	40/35	45/45	50/50	65/65	
Oil Charge, gallons ckt1/ckt2		1.8	1.8	1.7	2.2	1.8/1.8	1.8/1.8	1.7/1.7	1.7/1.7	2.3/2.2	
Shipping Weight	Alum. Fin Coils, lbs	1454	1567	1799	2034	2942	2968	3196	3208	4097	
	Copper Fin Coils, lbs	1597	1781	2005	2240	3300	3326	3673	3685	4703	
Operating Weight	Alum. Fin Coils, lbs	1481	1597	1829	2077	2967	3001	3233	3245	4142	
	Copper Fin Coils, lbs	1624	1811	2035	2283	3325	3359	3710	3722	4748	
Nominal Comp. Capacity	Comp. 1	8	10	15	15	10	12	13	15	20	
	Comp. 2	8	10	13	15	10	12	13	15	20	
	Comp. 3	-	-	-	-	-	-	-	-	-	
	Comp. 4	-	-	-	-	10	10	13	15	15	
	Comp. 5	-	-	-	-	10	10	13	15	15	
	Comp. 6	-	-	-	-	-	-	-	-	-	
Condenser	Total Face Area ft ²	34.7	34.7	43.5	43.5	87	87	116	116	128	
	Number of Rows Deep	Ckt. 1	2	3	3	3	2	2	3	3	3
		Ckt. 2	-	-	-	-	2	2	3	3	3
Fins per Inch		17	17	13	13	17	17	17	17	13	
Condenser Fans, Low Sound	Number of Fans	Ckt. 1	2	2	2	2	2	2	2	2	
		Ckt. 2	-	-	-	-	2	2	2	2	2
	Fan Power hp/fan		0.3	0.3	1.2	1.2	1.2	1.2	1.2	1.2	1.2
	Fan RPM		920	920	950	950	950	950	950	950	950
	Total Chiller CFM		10833	10833	20000	20000	39500	39500	43333	43333	43333
Condenser Fans, Ultra Quiet	Number of Fans	Ckt. 1	2	2	2	2	2	2	2	2	
		Ckt. 2	-	-	-	-	2	2	2	2	2
	Fan Power hp/fan		1.2	1.2	1.2	1.2	1.2	1.2	1.2	1.2	1.2
	Fan RPM		698	698	698	698	698	698	698	698	698
	Total Chiller CFM		20000	20000	20000	20000	39500	39500	43333	43333	43333
Evaporator	Water Volume Gallons		1.2	1.6	2.5	3.2	2.7	3.5	3.5	4.1	4.9
	Max Water Side Pressure PSIG		300	300	300	300	300	300	300	300	300
	Max Refrig Side Pressure PSIG		450	450	450	450	450	450	450	450	450
	Min. Chiller Water Flow GPM		10	10	10	10	40	40	60	60	60
	Max. Chiller Water Flow GPM		150	150	150	150	200	200	300	300	300
	Nom. Water Connections Size Inches		2	2	2	2	3	3	3	3	3

50Hz

Model No. YCAL00		19	22	28	33	43	46	52	56	66	
Length		2788.9	2788.9	3012.4	3012.4	3677.9	3677.9	3779.5	3779.5	3901.4	
Width		1135.4	1135.4	1135.4	1135.4	2301.2	2301.2	2301.2	2301.2	2301.2	
Height		1170.9	1170.9	1270	1270	1214.1	1214.1	1590	1590	1590	
Nominal Tons		51	62.6	85.4	98.4	122.7	133.6	158.9	158.9	211.2	
Number of Refrigerant Circuits		1	1	1	1	2	2	2	2	2	
Refrig. Chg, Opt, R-410A (kg) ckt1/ckt2		11.3	13.6	20.4	22.7	15.9/15.9	18.1/15.9	20.4/20.4	22.7/22.7	29.5/29.5	
Oil Charge, gallons ckt1/ckt2		6.8	6.8	6.5	8.3	6.8/6.8	6.8/6.8	6.4/6.4	6.4/6.4	8.7/8.3	
Shipping Weight	Alum. Fin Coils, lbs	659.5	710.8	816	922.6	1334.5	1346.3	1449.7	1455.1	1858.4	
	Copper Fin Coils, lbs	724.4	807.8	909.5	1016	1496.9	1508.6	1666	1671.5	2133.2	
Operating Weight	Alum. Fin Coils, lbs	671.8	724.4	829.6	942.1	1345.8	1361.2	1466.5	1471.9	1878.8	
	Copper Fin Coils, lbs	736.6	821.5	923.1	1035.6	1508.2	1523.6	1682.8	1688.3	2153.7	
Nominal Comp. Capacity	Comp. 1	28.1	35.1	52.7	52.7	35.1	42.2	45.7	52.7	70.3	
	Comp. 2	28.1	35.1	45.7	52.7	35.1	42.2	45.7	52.7	70.3	
	Comp. 3	-	-	-	-	-	-	-	-	-	
	Comp. 4	-	-	-	-	35.1	35.1	45.7	52.7	52.7	
	Comp. 5	-	-	-	-	35.1	35.1	45.7	52.7	52.7	
	Comp. 6	-	-	-	-	-	-	-	-	-	
Condenser	Total Face Area m²		3.2	3.2	4	4	8.1	8.1	10.8	10.8	11.9
	Number of Rows Deep	Ckt. 1	2	3	3	3	2	2	3	3	3
		Ckt. 2	-	-	-	-	2	2	3	3	3
	Fins per Inch		17	17	13	13	17	17	17	17	13
Condenser Fans, Low Sound	Number of Fans	Ckt. 1	2	2	2	2	2	2	2	2	
		Ckt. 2	-	-	-	-	2	2	2	2	2
	Fan Power kW/fan		0.2	0.2	0.9	0.9	0.9	0.9	0.9	0.9	0.9
	Fan RPM		920	920	950	950	950	950	950	950	950
	Total Chiller CFM		5112.6	5112.6	9438.9	9438.9	18641.7	18641.7	20450.7	20450.7	20450.7
Condenser Fans, Ultra Quiet	Number of Fans	Ckt. 1	2	2	2	2	2	2	2	2	
		Ckt. 2	-	-	-	-	2	2	2	2	2
	Fan Power hp/fan		0.9	0.9	0.9	0.9	0.9	0.9	0.9	0.9	0.9
	Fan RPM		698	698	698	698	698	698	698	698	698
	Total Chiller CFM		9438.9	9438.9	9438.9	9438.9	18641.7	18641.7	20450.7	20450.7	20450.7
Evaporator	Water Volume Liters		5.5	7.3	11.4	14.5	12.3	15.9	15.9	18.6	22.3
	Max Water Side Pressure Barg		20.7	20.7	20.7	20.7	20.7	20.7	20.7	20.7	20.7
	Max Refrig Side Pressure Barg		31	31	31	31	31	31	31	31	31
	Min. Chiller Water Flow l/s		0.6	0.6	0.6	0.6	2.5	2.5	3.8	3.8	3.8
	Max. Chiller Water Flow l/s		9.5	9.5	9.5	9.5	12.6	12.6	18.9	18.9	18.9
	Nom. Water Connections Size Inches		2	2	2	2	3	3	3	3	3

Dimensions - YCAL0019 (English)

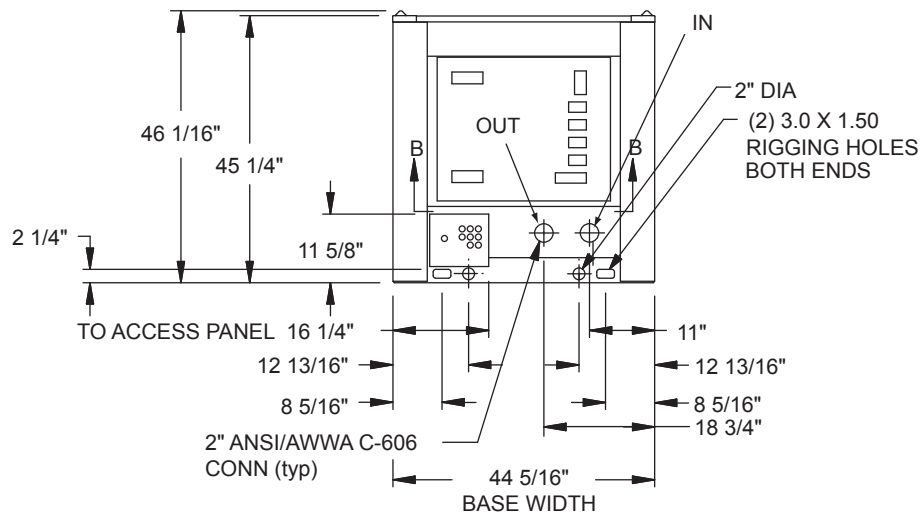
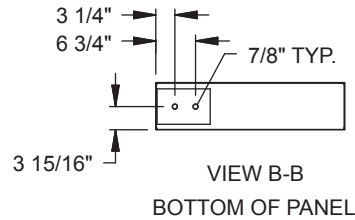

NOTE:

Placement on a level surface of free of obstructions (including snow, for winter operation) or air circulation ensures rated performance, reliable operation, and ease of maintenance. Site restrictions may compromise minimum clearances indicated below, resulting in unpredictable airflow patterns and possible diminished performance. YORK's unit controls will optimize operation without nuisance high-pressure safety cutouts; however, the system designer must consider potential performance degradation. Recommended minimum clearances: front to wall – 6'; rear to wall – 6'; cooler end to wall – 4'0"; coil end to wall - 6'; top – no obstructions allowed; distance between adjacent units – 10'. No more than one adjacent wall may be higher than the unit. 1" nominal deflection isolators (not shown) will increase overall unit height by 6".

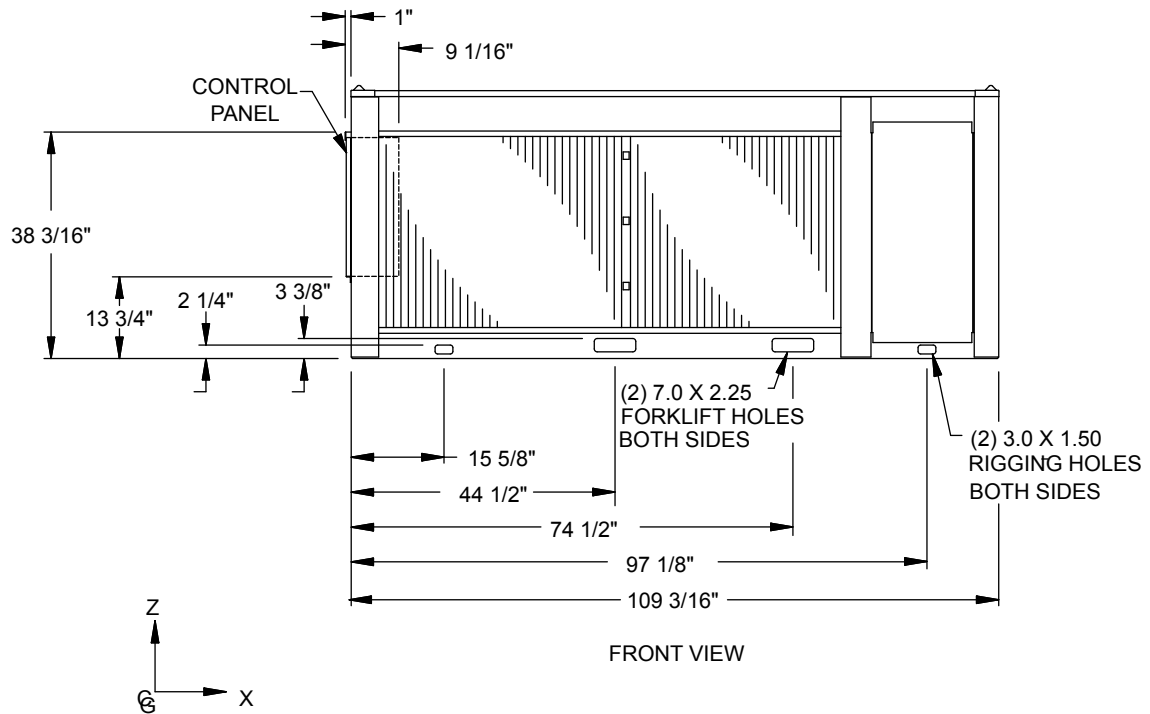
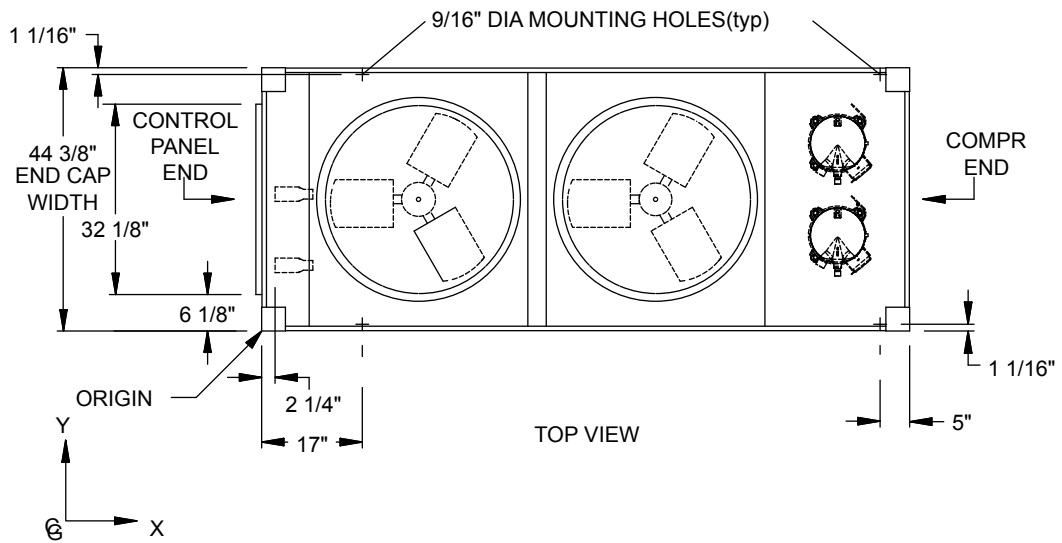

Dimensions - YCAL0022 (English)

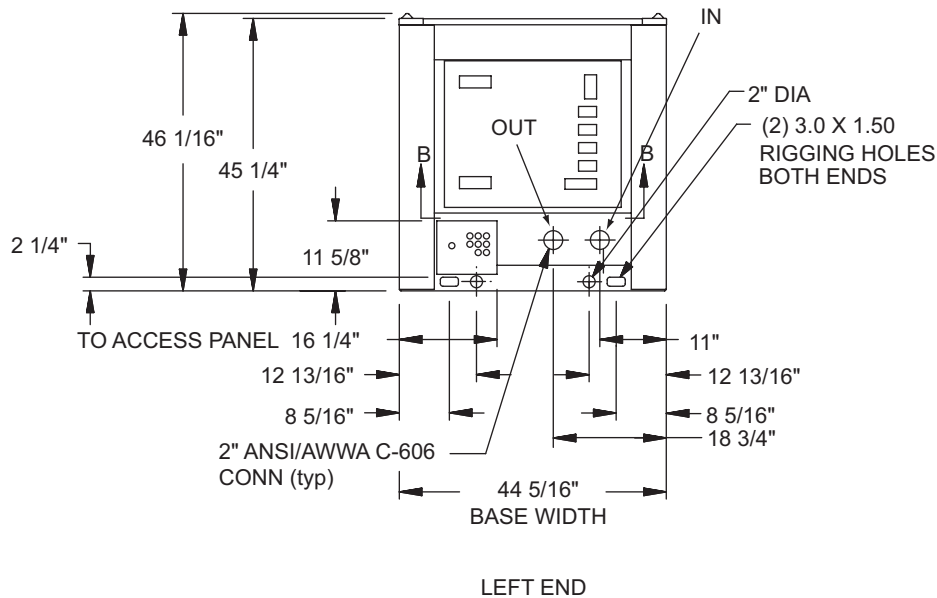
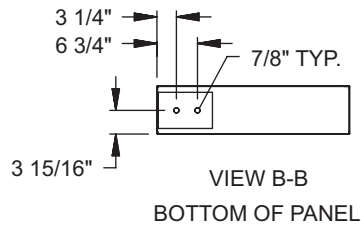

POWER: SINGLE POINT SUPPLY WITH TERMINAL BLOCK

NOTE:

Placement on a level surface of free of obstructions (including snow, for winter operation) or air circulation ensures rated performance, reliable operation, and ease of maintenance. Site restrictions may compromise minimum clearances indicated below, resulting in unpredictable airflow patterns and possible diminished performance. YORK's unit controls will optimize operation without nuisance high-pressure safety cutouts; however, the system designer must consider potential performance degradation. Recommended minimum clearances: front to wall – 6'; rear to wall – 6'; cooler end to wall – 4'0"; coil end to wall - 6'; top – no obstructions allowed; distance between adjacent units – 10'. No more than one adjacent wall may be higher than the unit. 1" nominal deflection isolators (not shown) will increase overall unit height by 6".

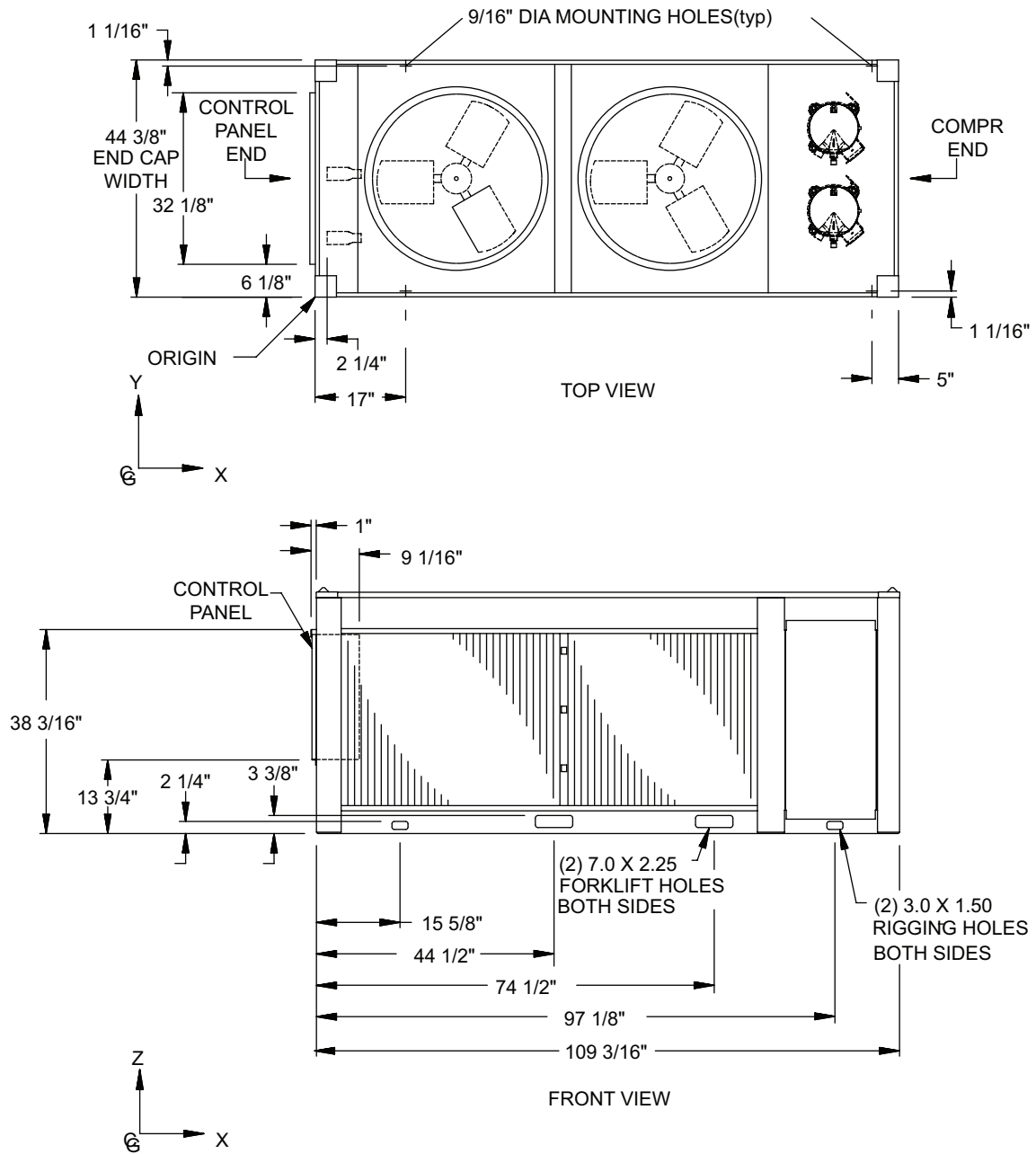

Dimensions - YCAL0028 (English)

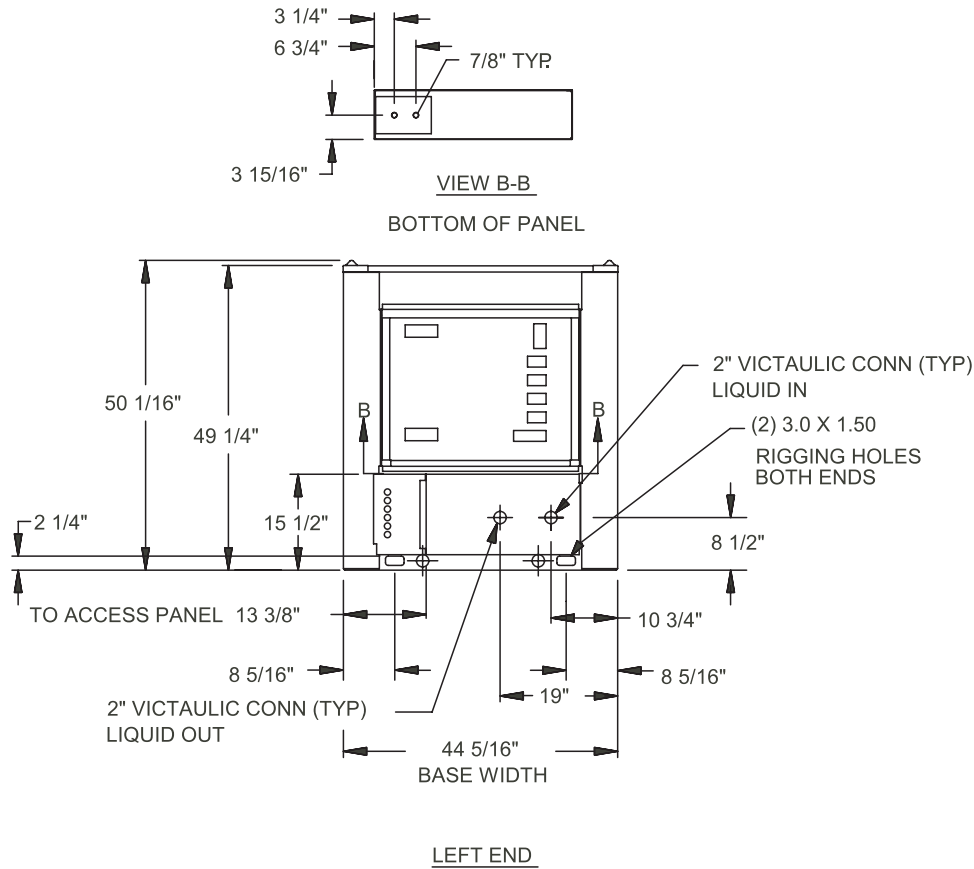

POWER: SINGLE POINT SUPPLY WITH TERMINAL BLOCK

NOTE:

Placement on a level surface of free of obstructions (including snow, for winter operation) or air circulation ensures rated performance, reliable operation, and ease of maintenance. Site restrictions may compromise minimum clearances indicated below, resulting in unpredictable airflow patterns and possible diminished performance. YORK's unit controls will optimize operation without nuisance high-pressure safety cutouts; however, the system designer must consider potential performance degradation. Recommended minimum clearances: front to wall – 6'; rear to wall – 6'; cooler end to wall – 4'0"; coil end to wall - 6'; top – no obstructions allowed; distance between adjacent units – 10'. No more than one adjacent wall may be higher than the unit. 1" nominal deflection isolators (not shown) will increase overall unit height by 6".

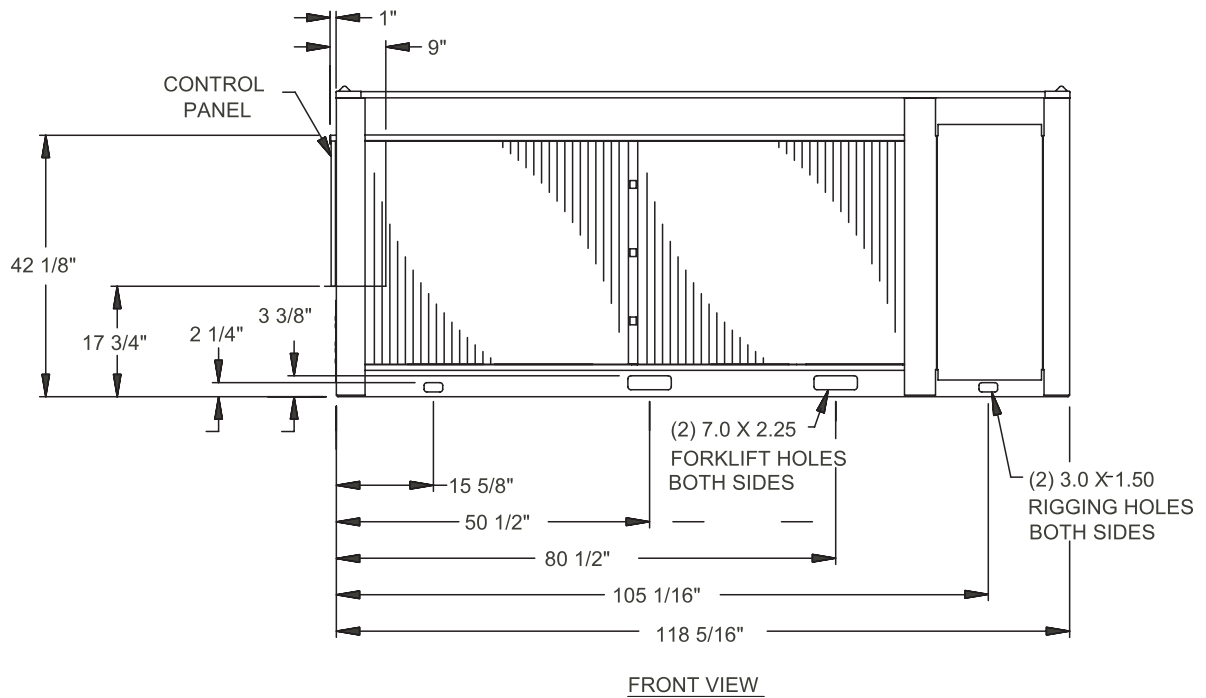
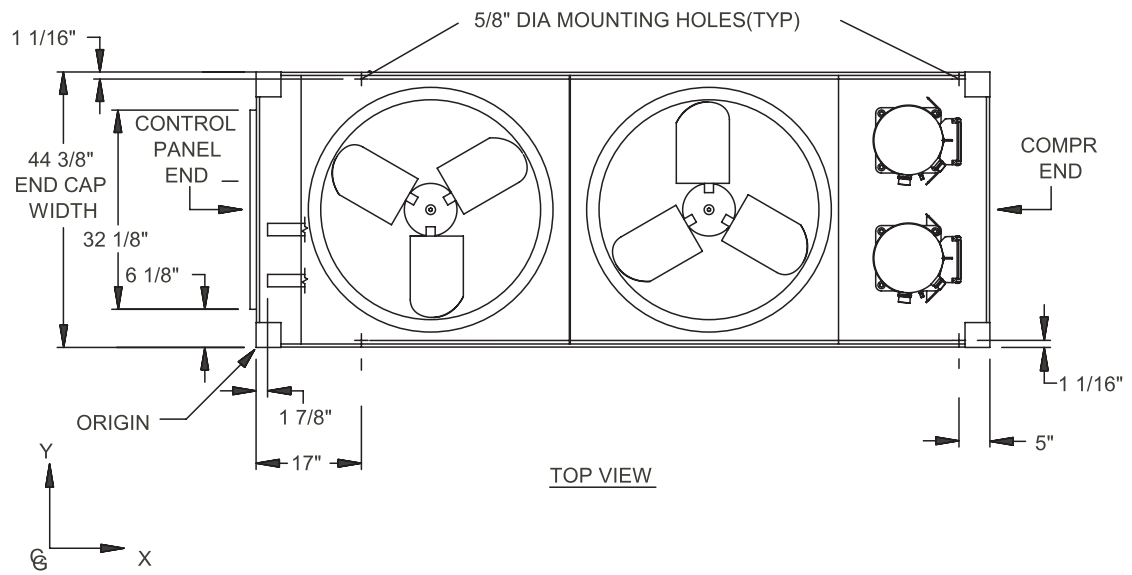

Dimensions - YCAL0033 (English)

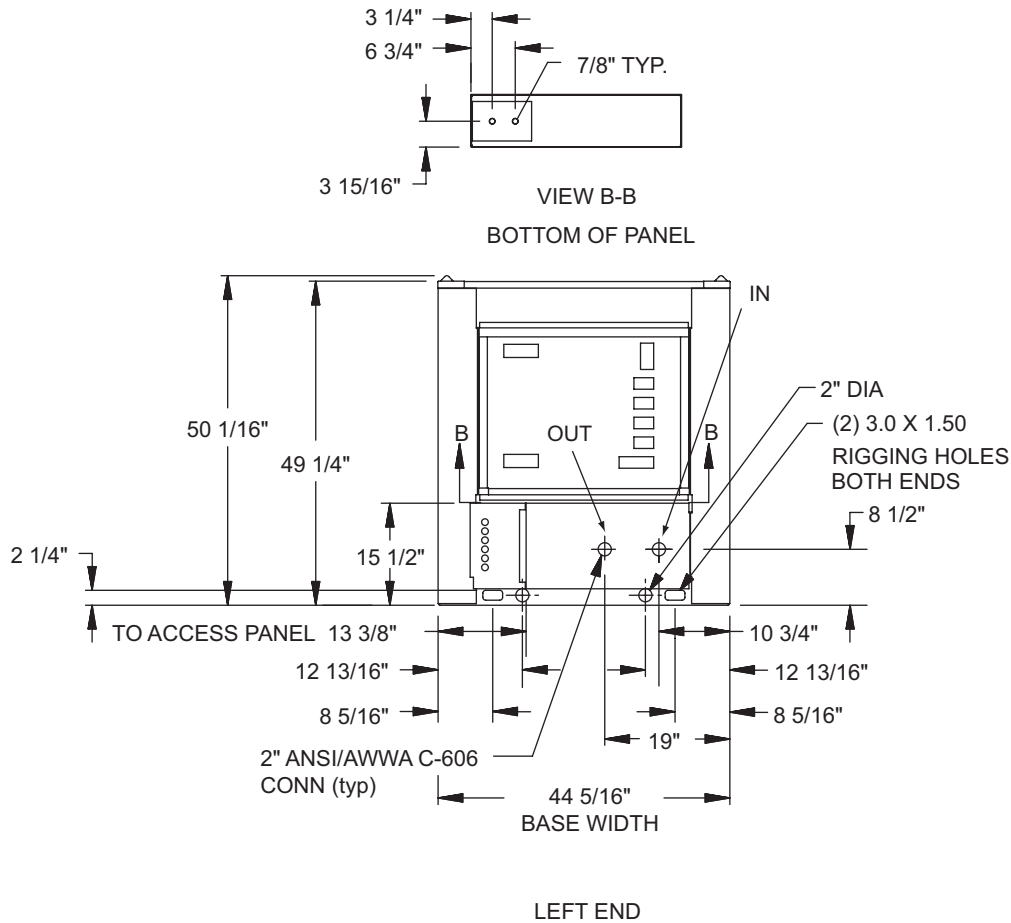

POWER: SINGLE POINT SUPPLY WITH TERMINAL BLOCK

NOTE:

Placement on a level surface of free of obstructions (including snow, for winter operation) or air circulation ensures rated performance, reliable operation, and ease of maintenance. Site restrictions may compromise minimum clearances indicated below, resulting in unpredictable airflow patterns and possible diminished performance. YORK's unit controls will optimize operation without nuisance high-pressure safety cutouts; however, the system designer must consider potential performance degradation. Recommended minimum clearances: front to wall – 6'; rear to wall – 6'; cooler end to wall – 4'0"; coil end to wall - 6'; top – no obstructions allowed; distance between adjacent units – 10'. No more than one adjacent wall may be higher than the unit. 1" nominal deflection isolators (not shown) will increase overall unit height by 6".

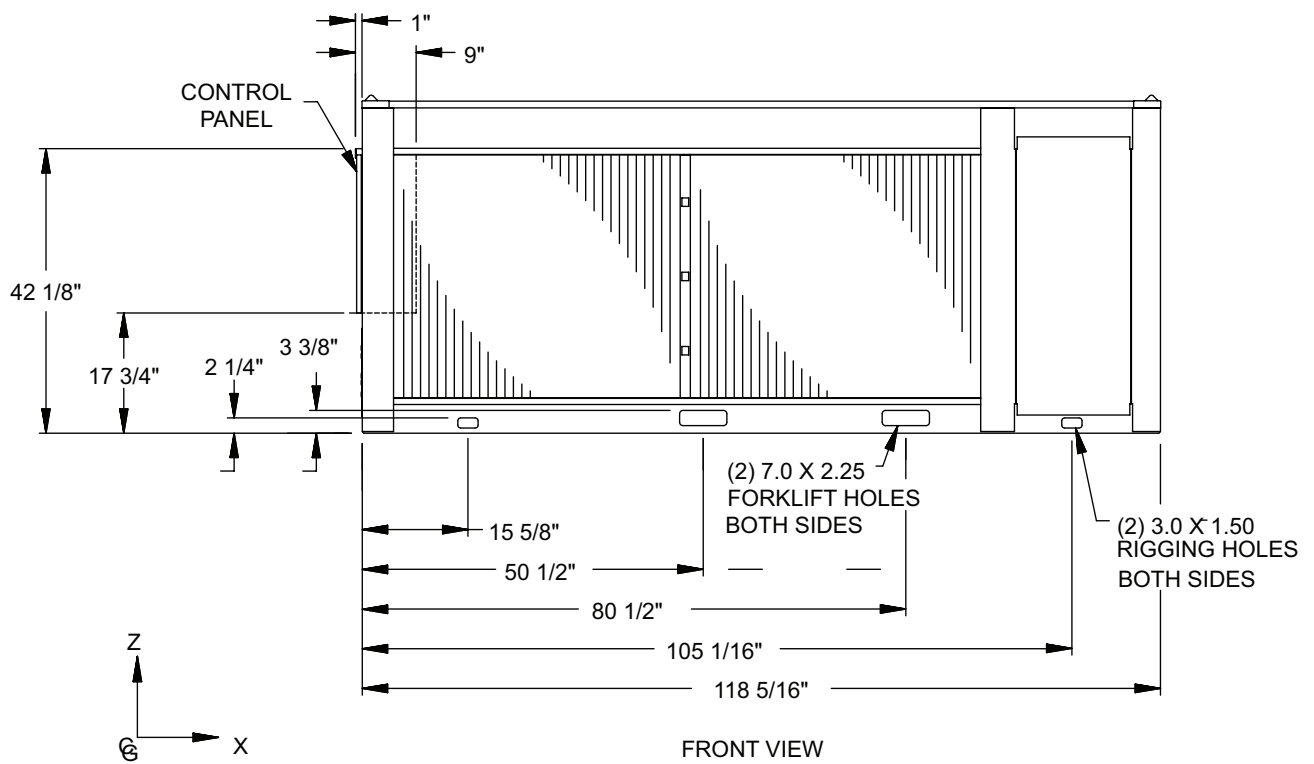
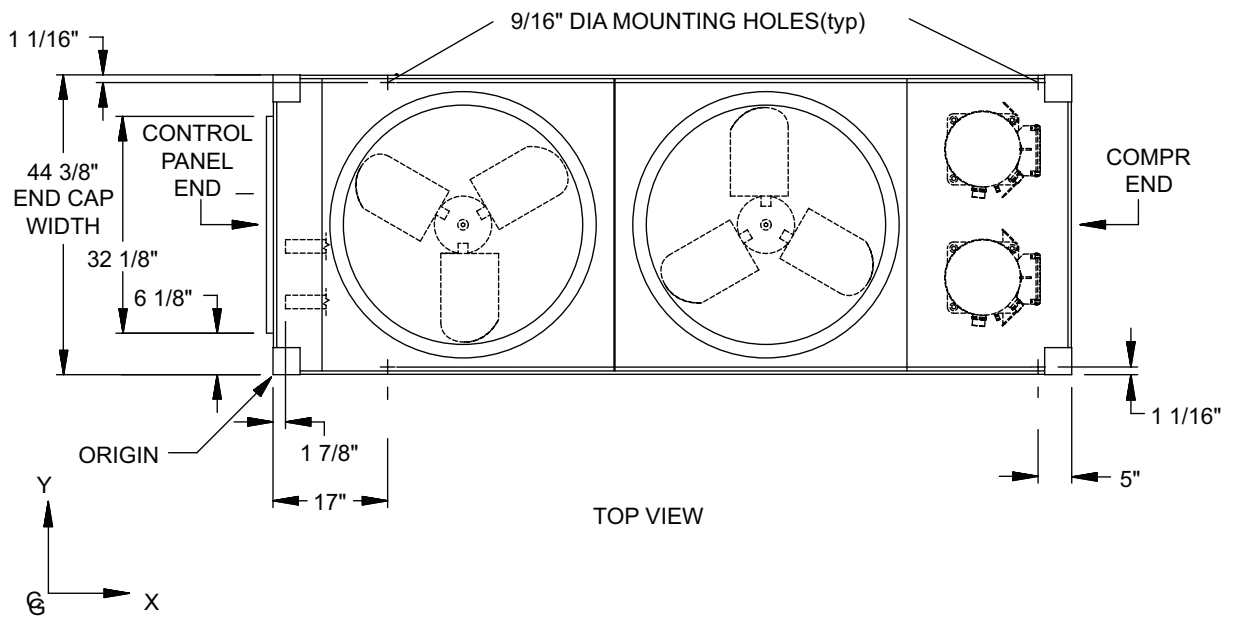

Dimensions - YCAL0043 (English)

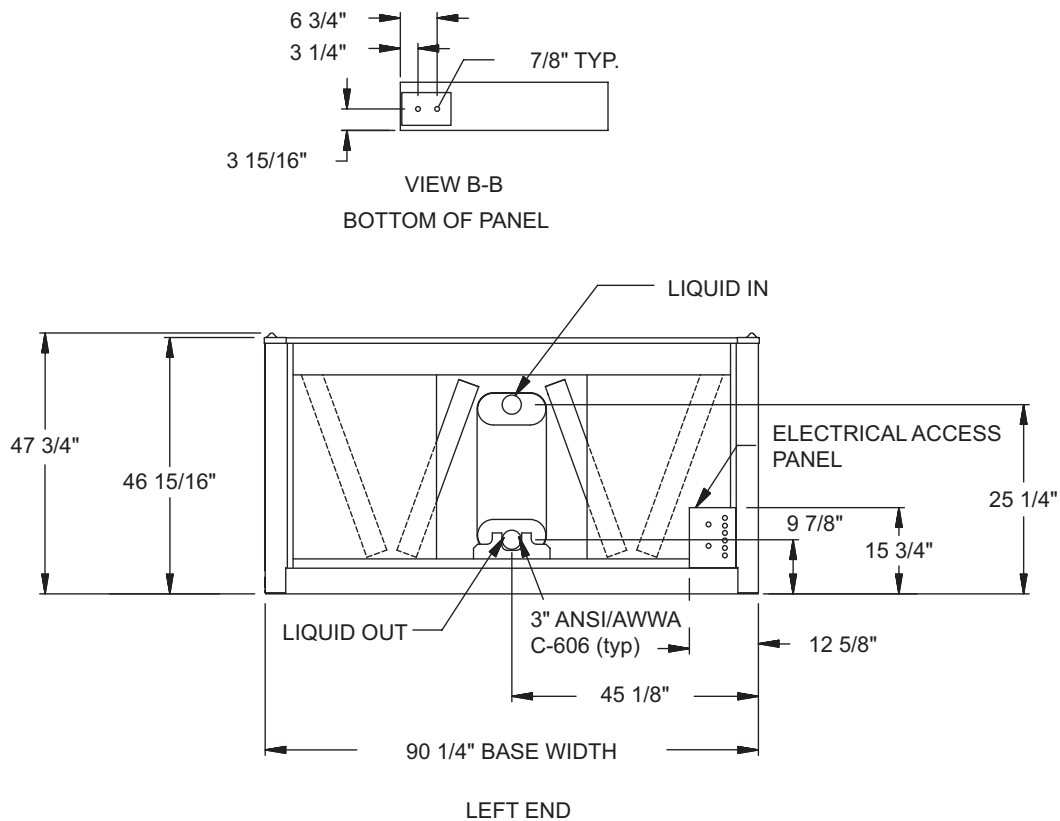
**NOTE:**

Placement on a level surface of free of obstructions (including snow, for winter operation) or air circulation ensures rated performance, reliable operation, and ease of maintenance. Site restrictions may compromise minimum clearances indicated below, resulting in unpredictable airflow patterns and possible diminished performance. YORK's unit controls will optimize operation without nuisance high-pressure safety cutouts; however, the system designer must consider potential performance degradation. Recommended minimum clearances: front to wall – 6'; rear to wall – 6'; cooler end to wall – 4'0"; coil end to wall - 6'; top – no obstructions allowed; distance between adjacent units – 10'. No more than one adjacent wall may be higher than the unit. 1" nominal deflection isolators (not shown) will increase overall unit height by 6".

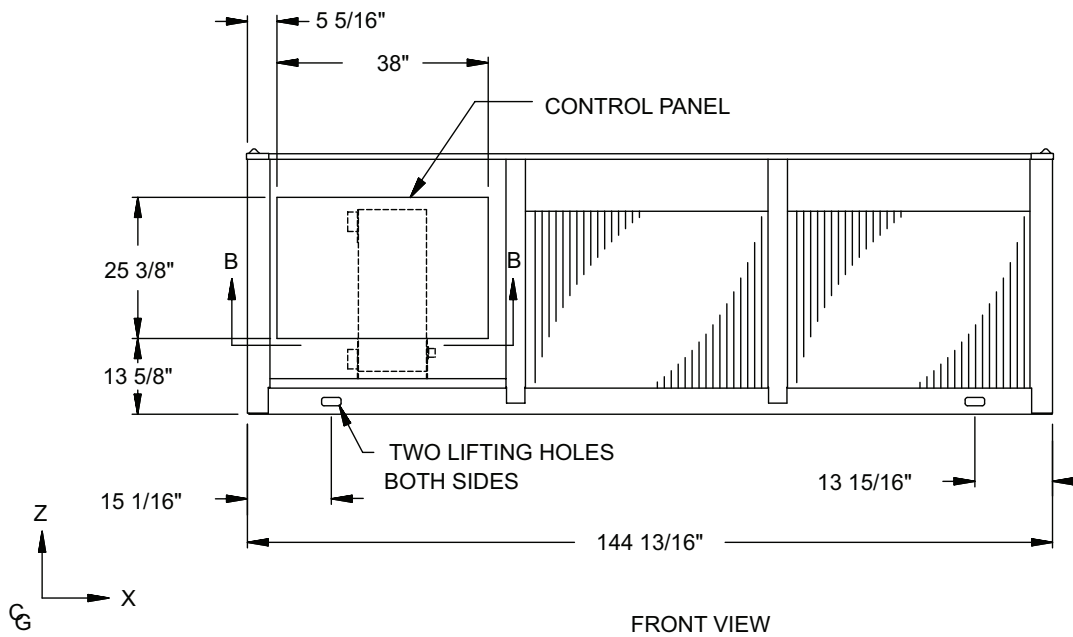
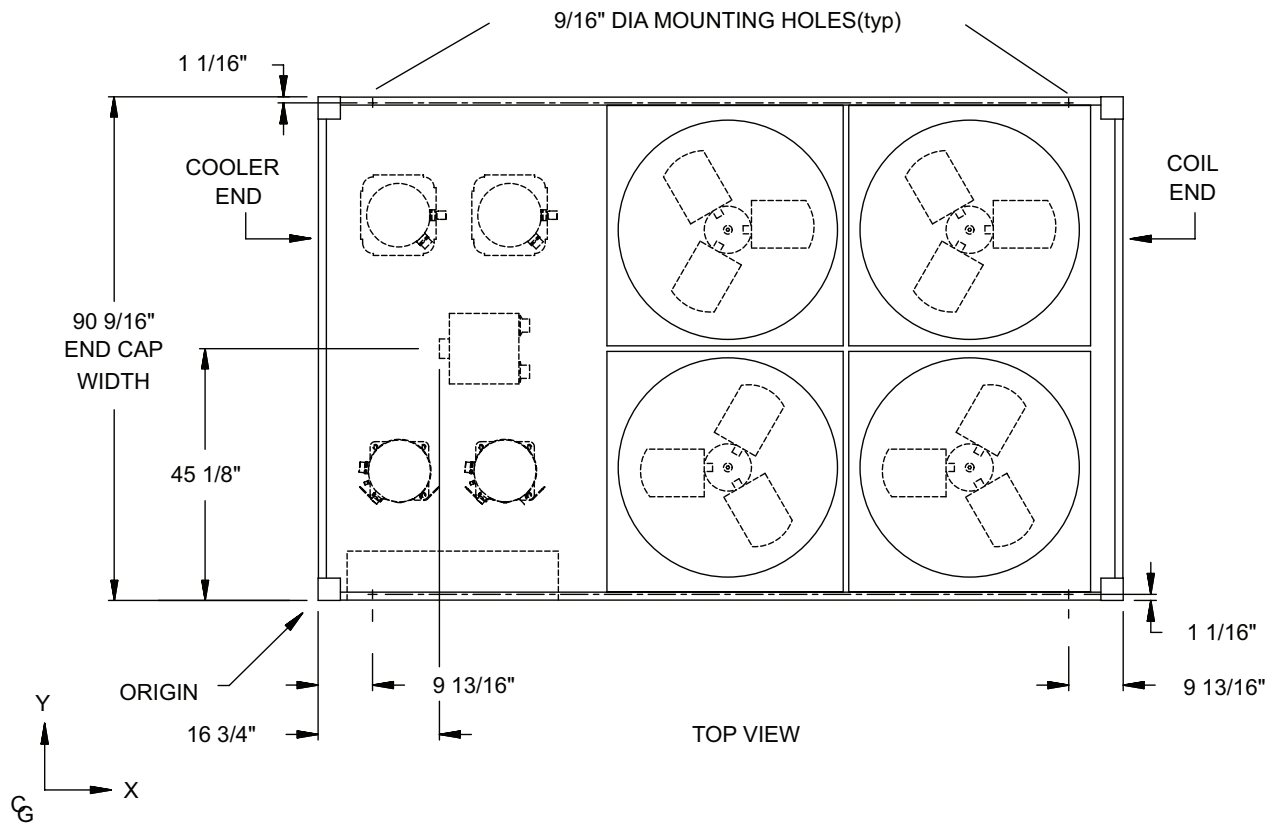

Dimensions - YCAL0046 (English)

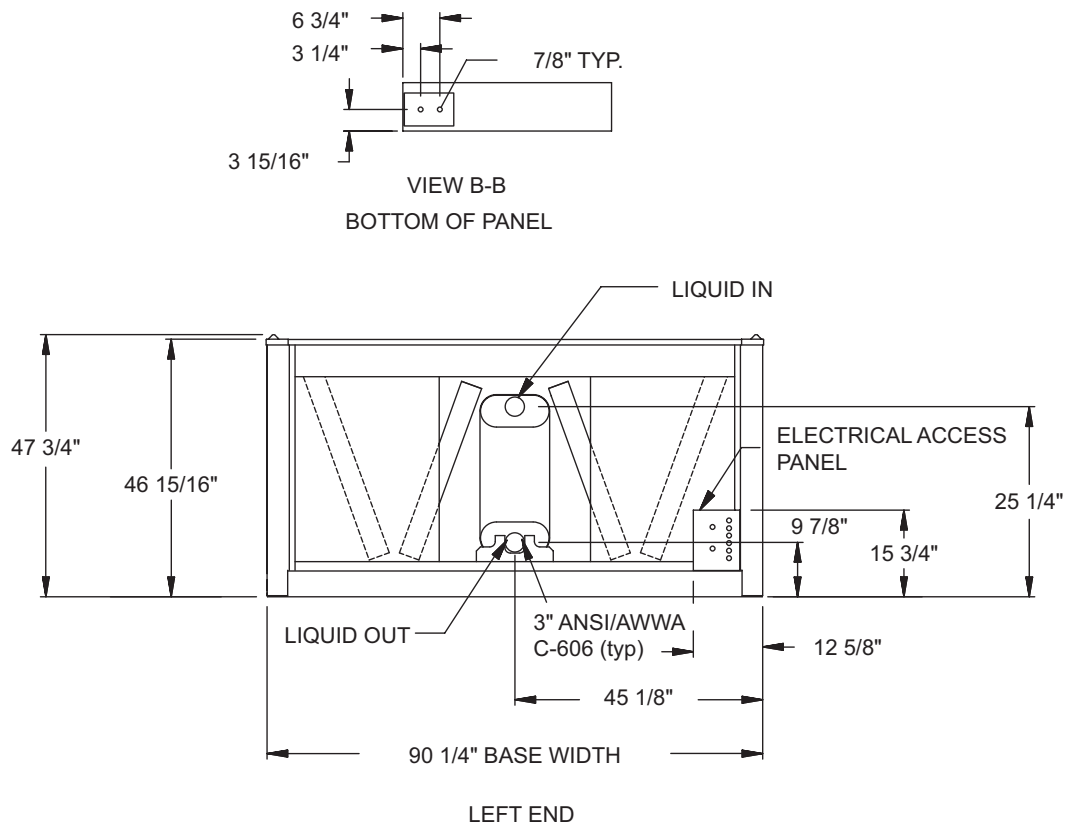

NOTE:

Placement on a level surface of free of obstructions (including snow, for winter operation) or air circulation ensures rated performance, reliable operation, and ease of maintenance. Site restrictions may compromise minimum clearances indicated below, resulting in unpredictable airflow patterns and possible diminished performance. YORK's unit controls will optimize operation without nuisance high-pressure safety cutouts; however, the system designer must consider potential performance degradation. Recommended minimum clearances: front to wall - 6'; rear to wall - 6'; cooler end to wall - 4'0"; coil end to wall - 6'; top - no obstructions allowed; distance between adjacent units - 10'. No more than one adjacent wall may be higher than the unit. 1" nominal deflection isolators (not shown) will increase overall unit height by 6".

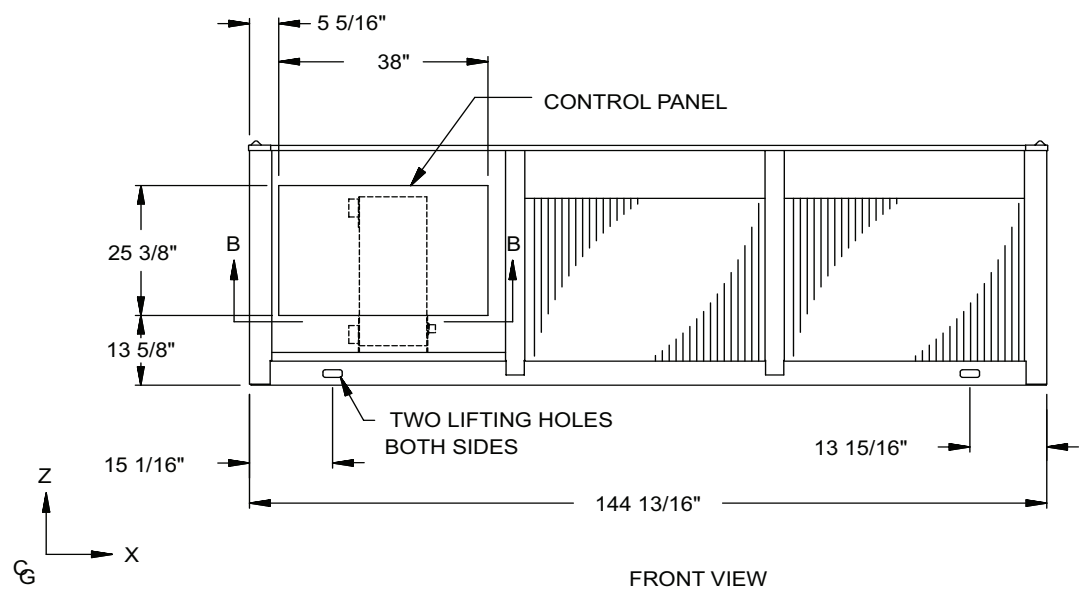
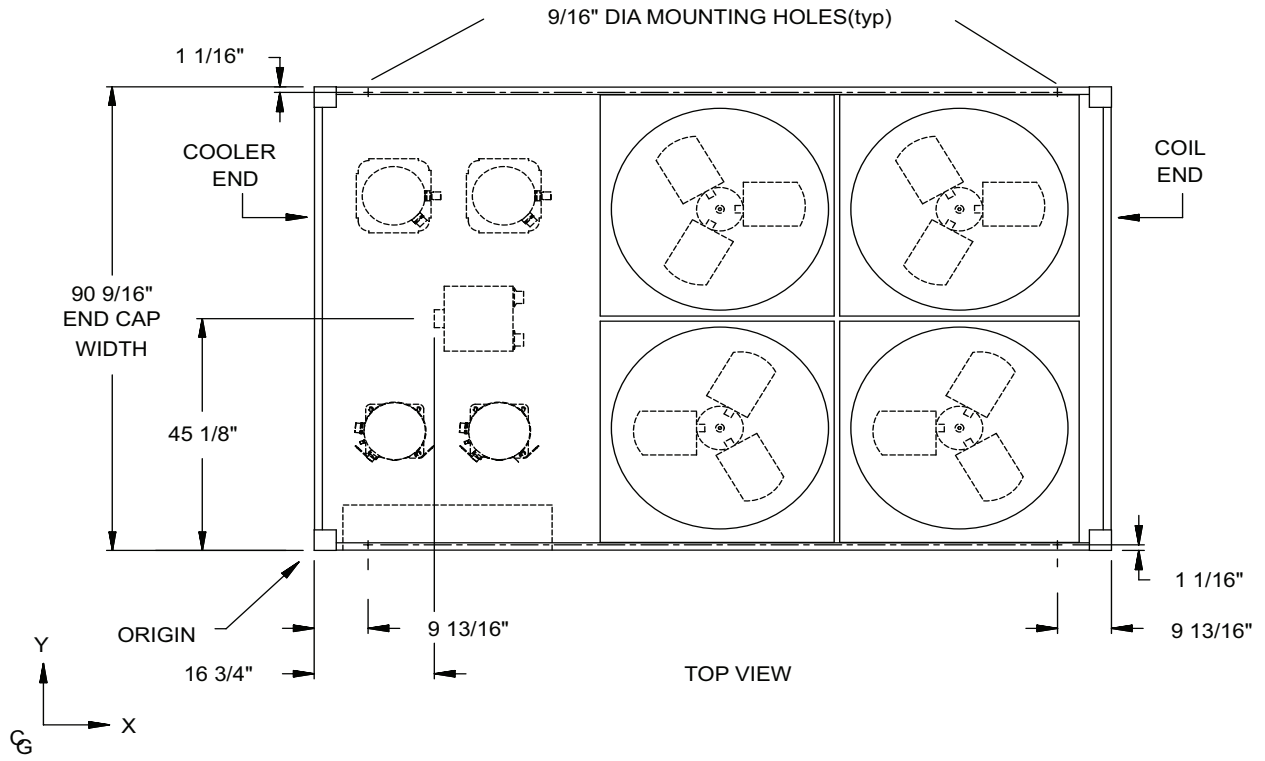

Dimensions - YCAL0052 (English)

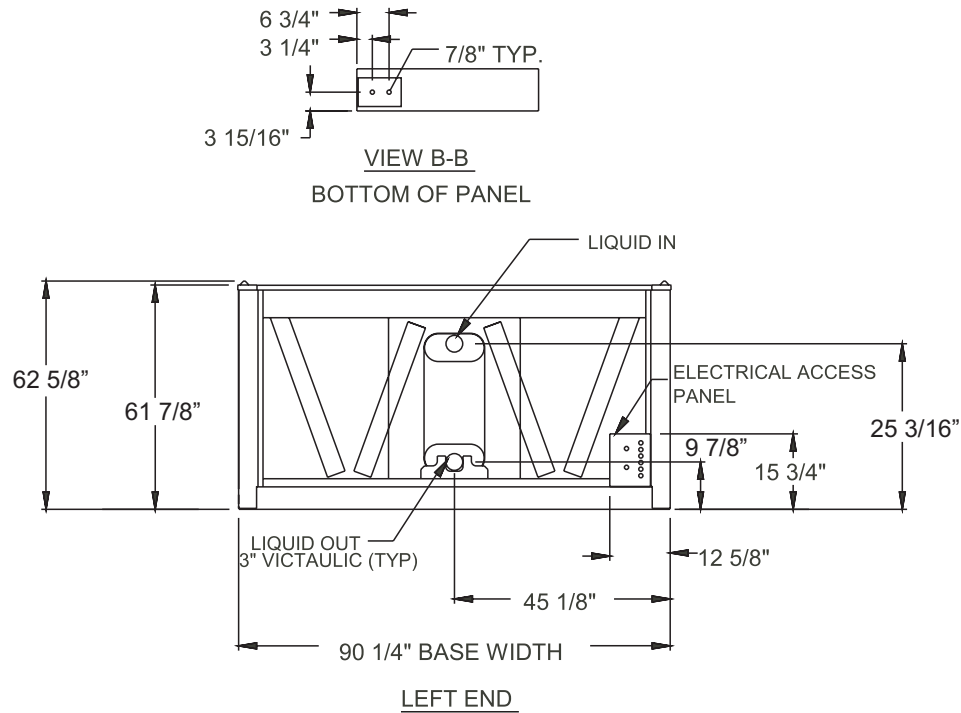

POWER: SINGLE POINT SUPPLY WITH TERMINAL BLOCK

NOTE:

Placement on a level surface of free of obstructions (including snow, for winter operation) or air circulation ensures rated performance, reliable operation, and ease of maintenance. Site restrictions may compromise minimum clearances indicated below, resulting in unpredictable airflow patterns and possible diminished performance. YORK's unit controls will optimize operation without nuisance high-pressure safety cutouts; however, the system designer must consider potential performance degradation. Recommended minimum clearances: front to wall – 6'; rear to wall – 6'; cooler end to wall – 4'0"; coil end to wall - 6'; top – no obstructions allowed; distance between adjacent units – 10'. No more than one adjacent wall may be higher than the unit. 1" nominal deflection isolators (not shown) will increase overall unit height by 6".

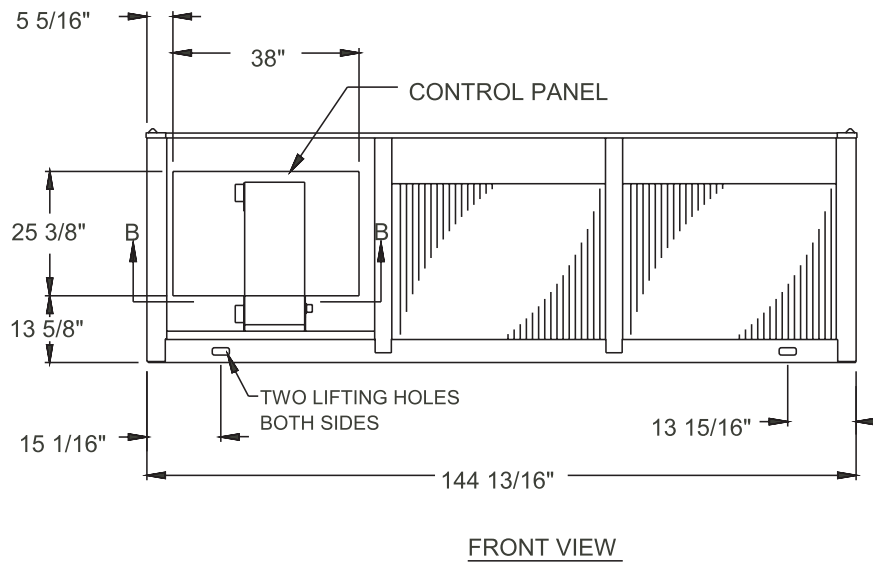
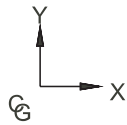
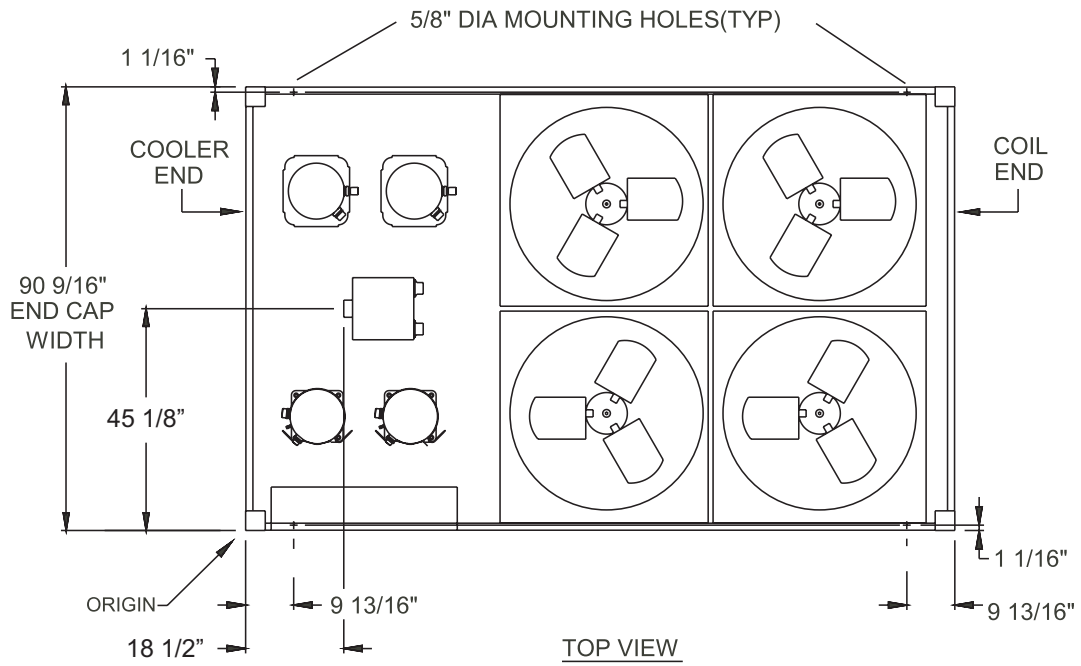

Dimensions - YCAL0056 (English)

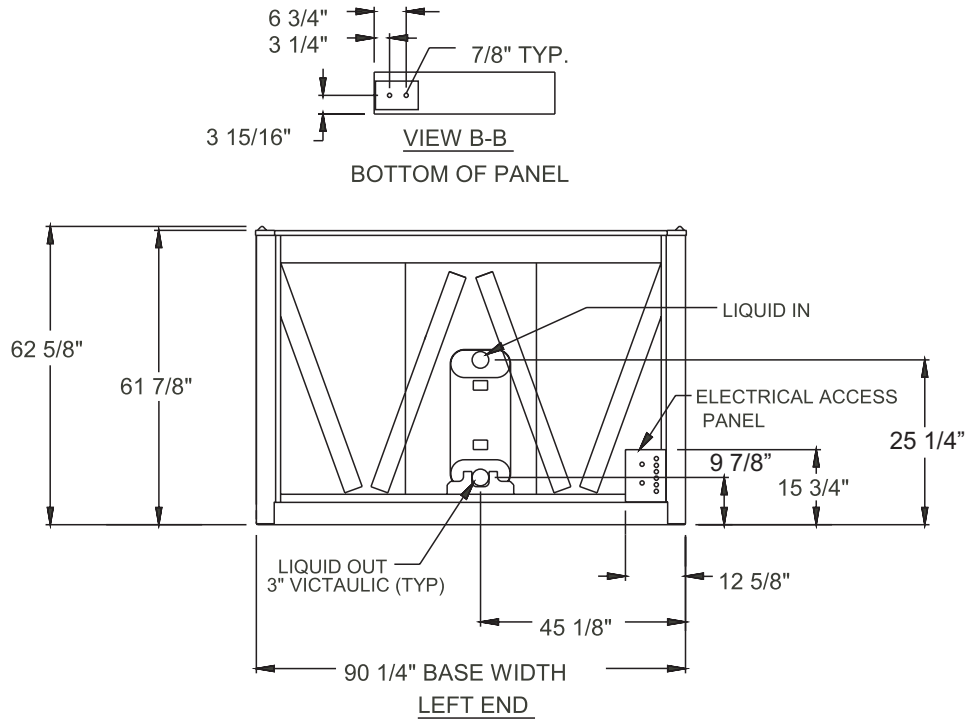

POWER: SINGLE POINT SUPPLY WITH TERMINAL BLOCK

NOTE:

Placement on a level surface of free of obstructions (including snow, for winter operation) or air circulation ensures rated performance, reliable operation, and ease of maintenance. Site restrictions may compromise minimum clearances indicated below, resulting in unpredictable airflow patterns and possible diminished performance. YORK's unit controls will optimize operation without nuisance high-pressure safety cutouts; however, the system designer must consider potential performance degradation. Recommended minimum clearances: front to wall – 6'; rear to wall – 6'; cooler end to wall – 4'0"; coil end to wall - 6'; top – no obstructions allowed; distance between adjacent units – 10'. No more than one adjacent wall may be higher than the unit. 1" nominal deflection isolators (not shown) will increase overall unit height by 6".

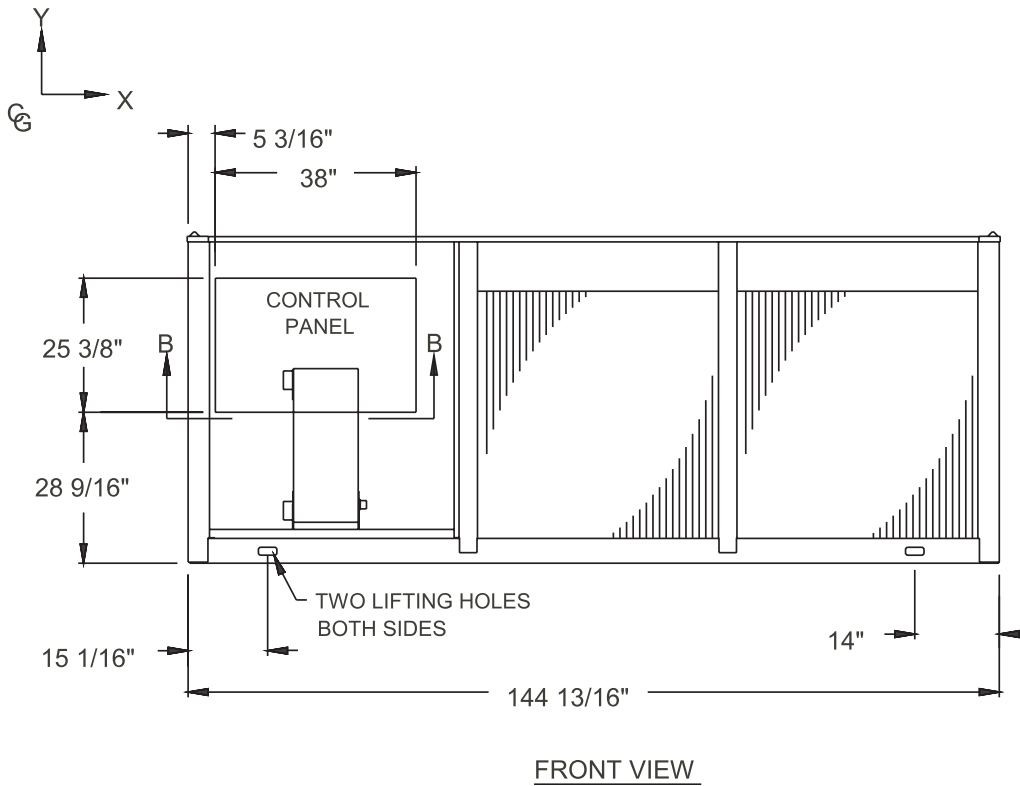
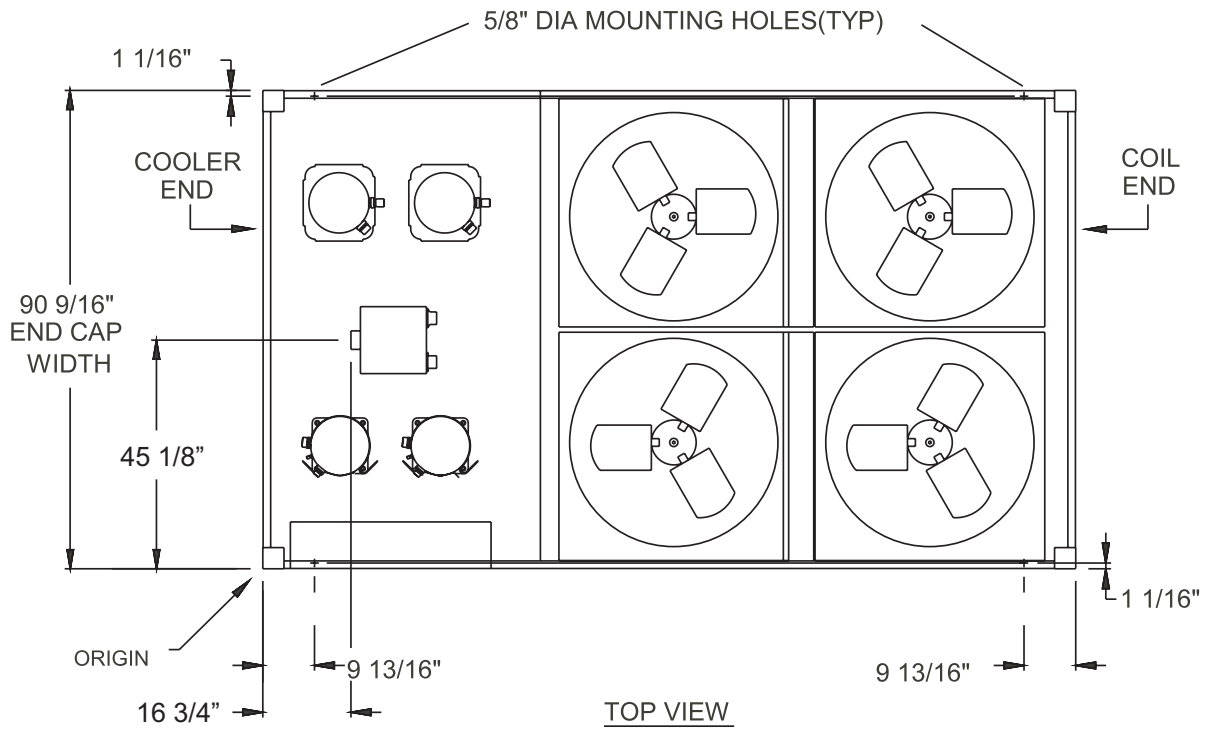

Dimensions - YCAL0066 (English)

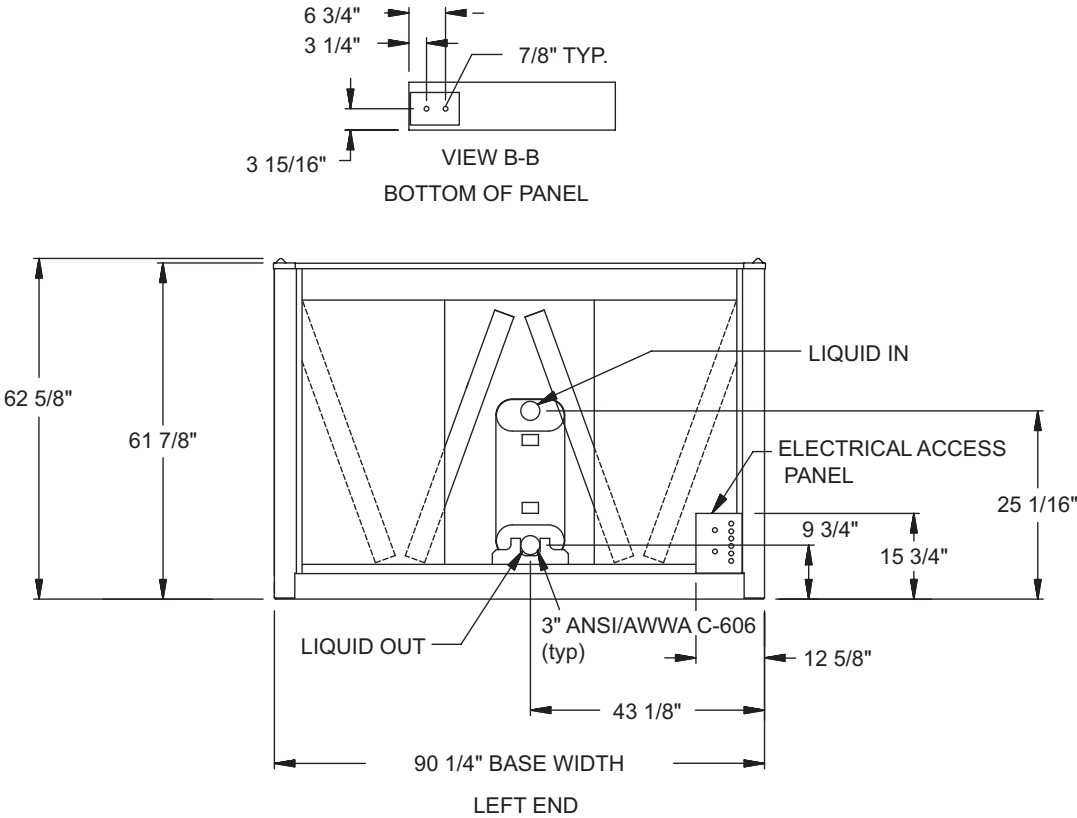

NOTE:

Placement on a level surface of free of obstructions (including snow, for winter operation) or air circulation ensures rated performance, reliable operation, and ease of maintenance. Site restrictions may compromise minimum clearances indicated below, resulting in unpredictable airflow patterns and possible diminished performance. YORK's unit controls will optimize operation without nuisance high-pressure safety cutouts; however, the system designer must consider potential performance degradation. Recommended minimum clearances: front to wall - 6'; rear to wall - 6'; cooler end to wall - 4'0"; coil end to wall - 6'; top - no obstructions allowed; distance between adjacent units - 10'. No more than one adjacent wall may be higher than the unit. 1" nominal deflection isolators (not shown) will increase overall unit height by 6".

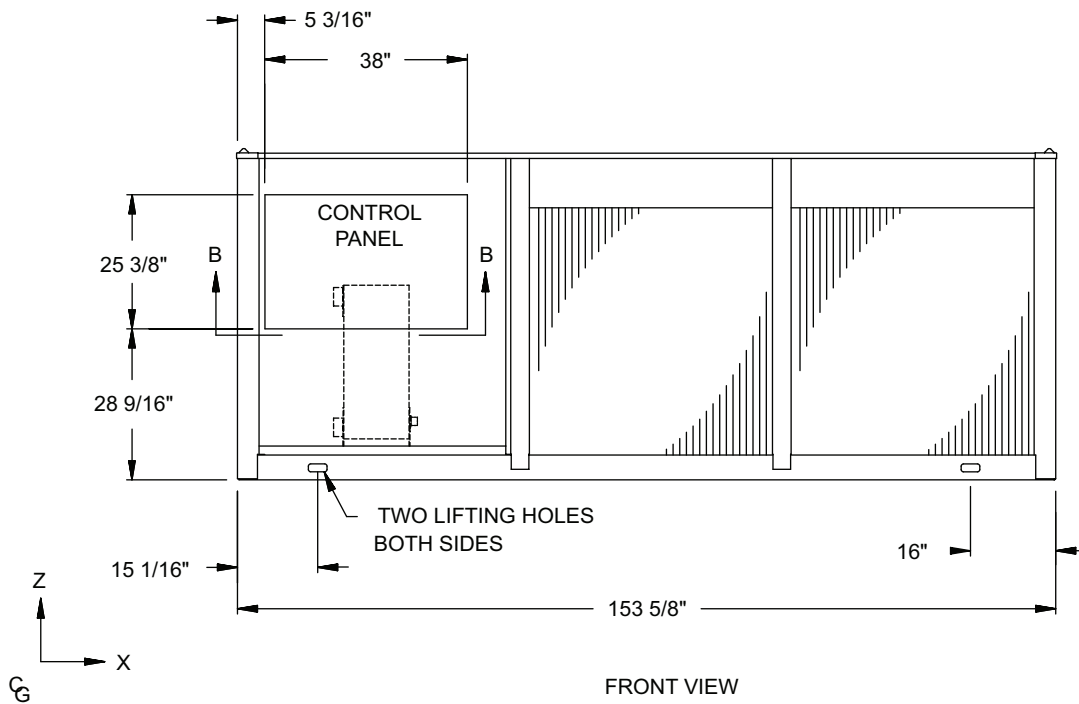
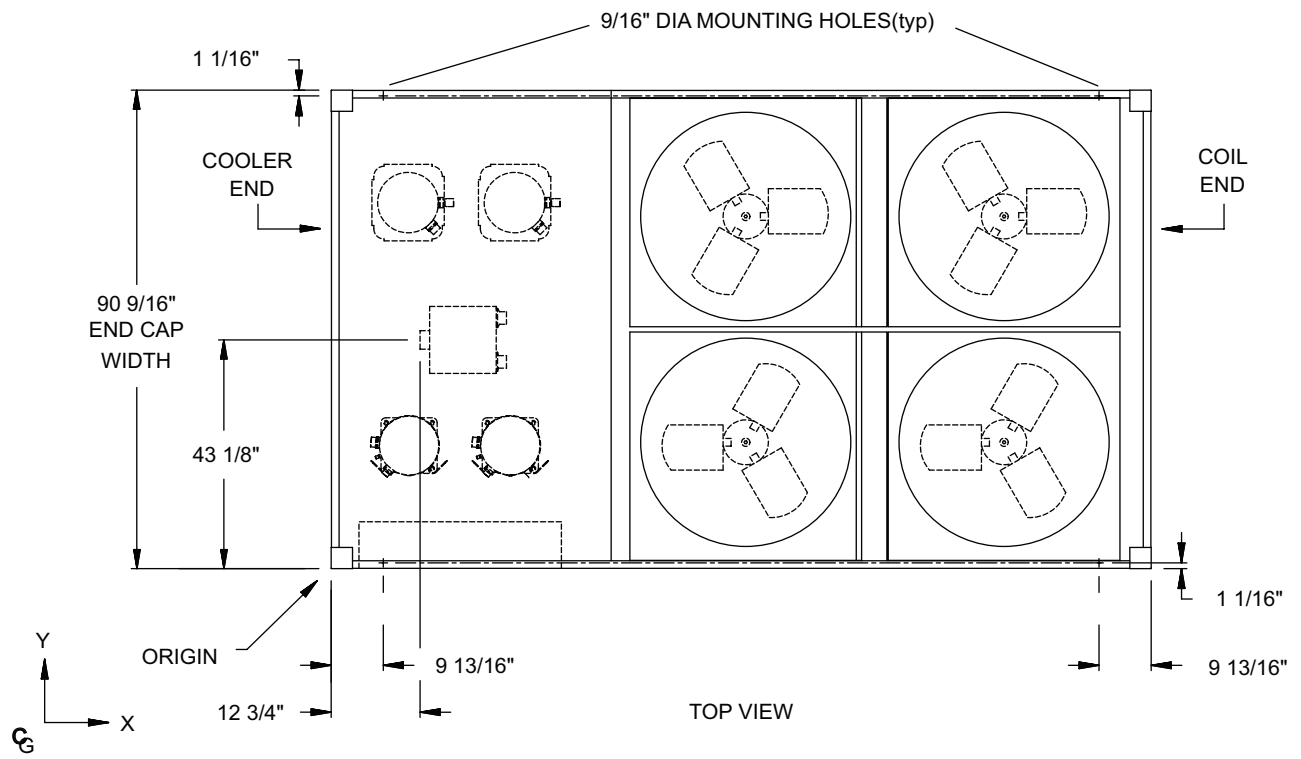

Dimensions - YCAL0019 (SI)

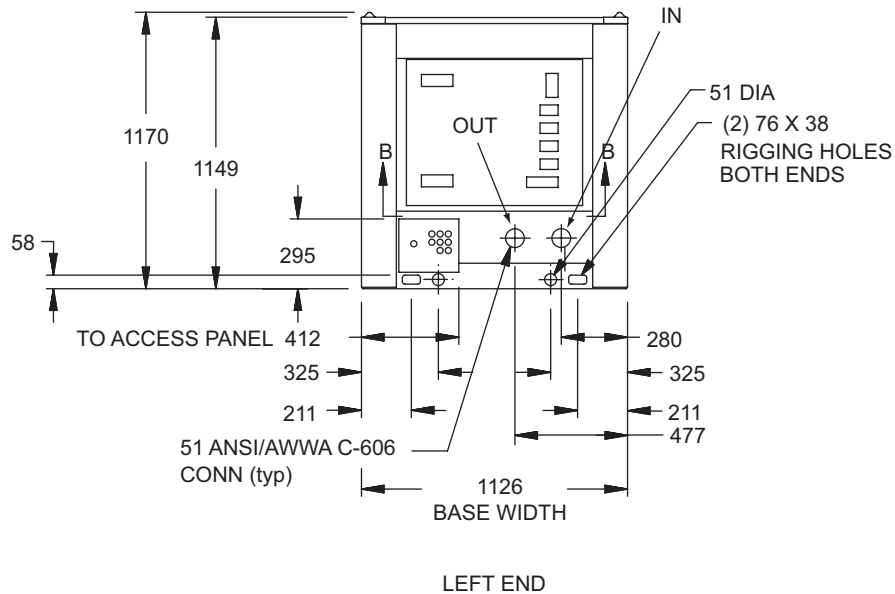
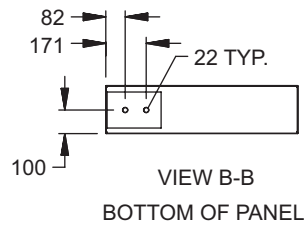

POWER: SINGLE POINT SUPPLY WITH TERMINAL BLOCK

NOTE: All dimensions are in mm unless specified otherwise.

NOTE:

Placement on a level surface of free of obstructions (including snow, for winter operation) or air circulation ensures rated performance, reliable operation, and ease of maintenance. Site restrictions may compromise minimum clearances indicated below, resulting in unpredictable airflow patterns and possible diminished performance. YORK's unit controls will optimize operation without nuisance high-pressure safety cutouts; however, the system designer must consider potential performance degradation. Recommended minimum clearances: front to wall – 2m; rear to wall – 2m; cooler end to wall – 1.2m; coil end to wall – 2m; top – no obstructions allowed; distance between adjacent units – 3m. No more than one adjacent wall may be higher than the unit. 1" nominal deflection isolators (not shown) will increase overall unit height by 152mm.

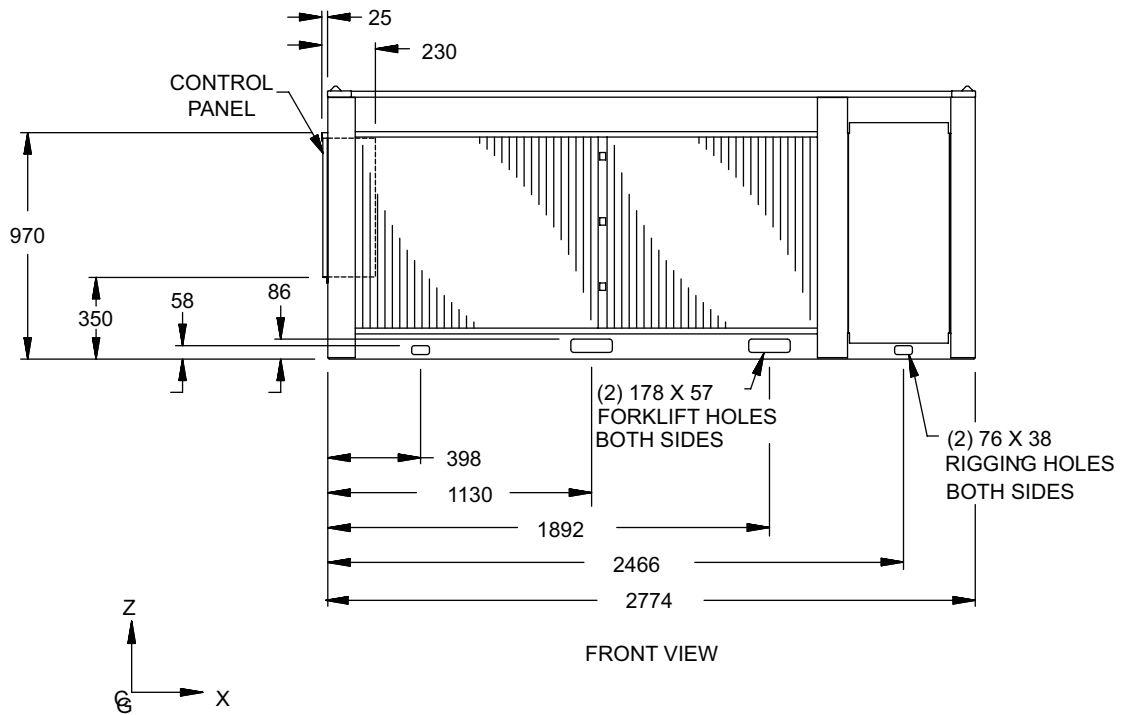
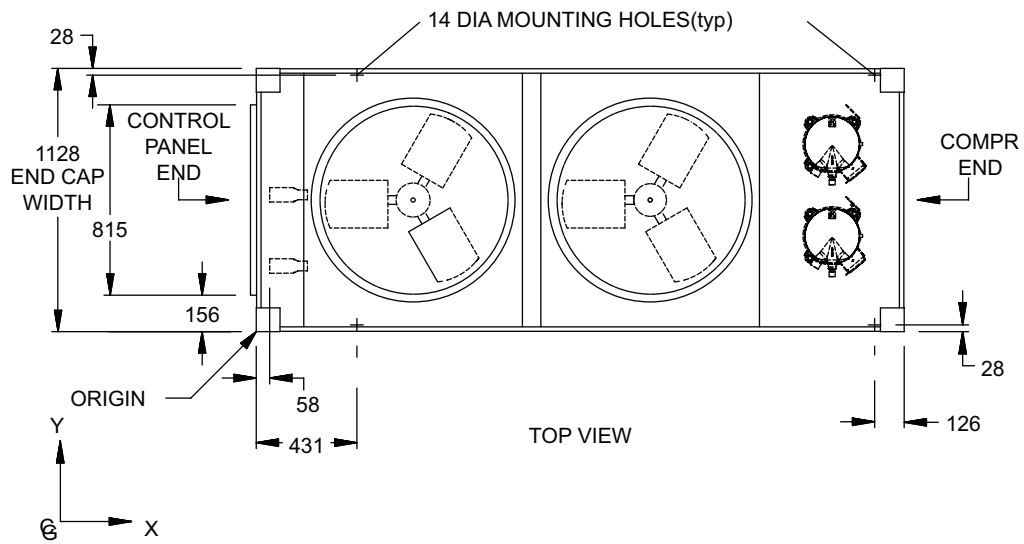

Dimensions - YCAL0022 (SI)

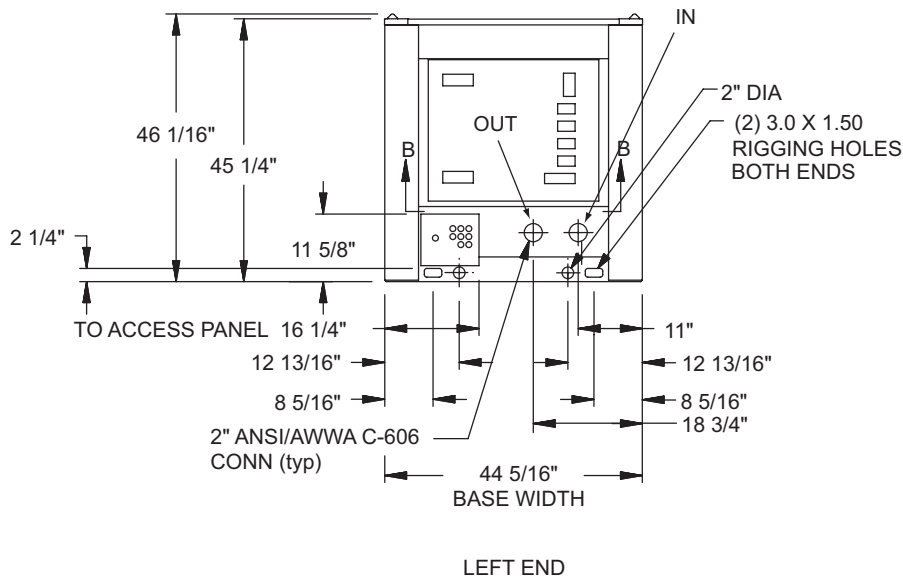
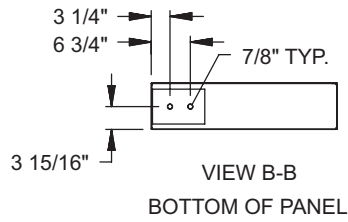

POWER: SINGLE POINT SUPPLY WITH TERMINAL BLOCK

NOTE: All dimensions are in mm unless specified otherwise.

NOTE:

Placement on a level surface of free of obstructions (including snow, for winter operation) or air circulation ensures rated performance, reliable operation, and ease of maintenance. Site restrictions may compromise minimum clearances indicated below, resulting in unpredictable airflow patterns and possible diminished performance. YORK's unit controls will optimize operation without nuisance high-pressure safety cutouts; however, the system designer must consider potential performance degradation. Recommended minimum clearances: front to wall - 2m; rear to wall - 2m; cooler end to wall - 1.2m; coil end to wall - 2m; top - no obstructions allowed; distance between adjacent units - 3m. No more than one adjacent wall may be higher than the unit. 1" nominal deflection isolators (not shown) will increase overall unit height by 152mm.

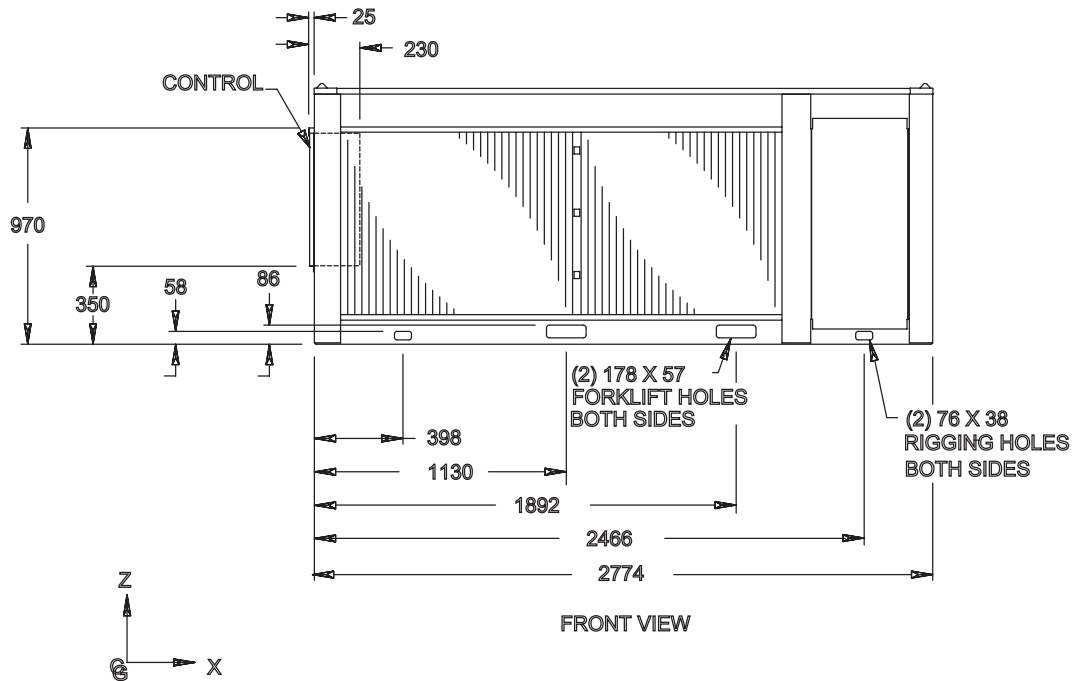
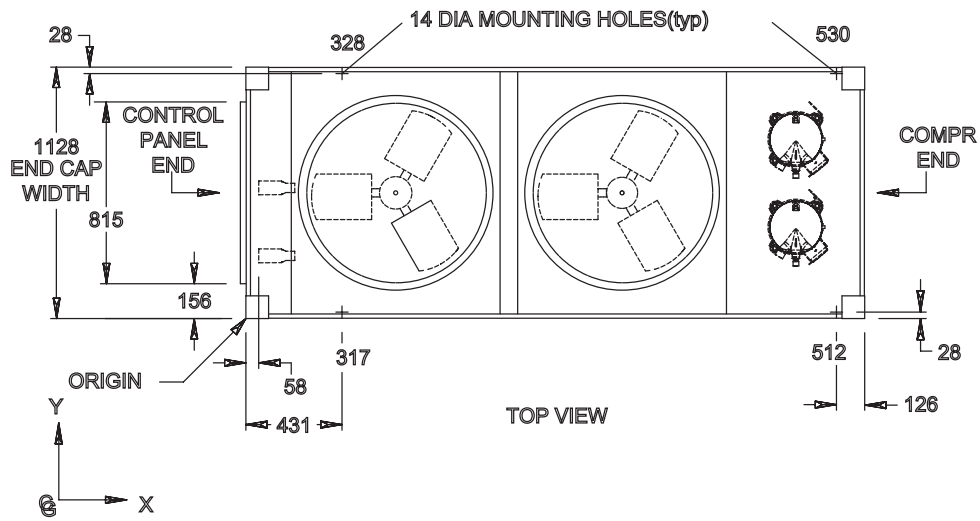

Dimensions - YCAL0028 (SI)

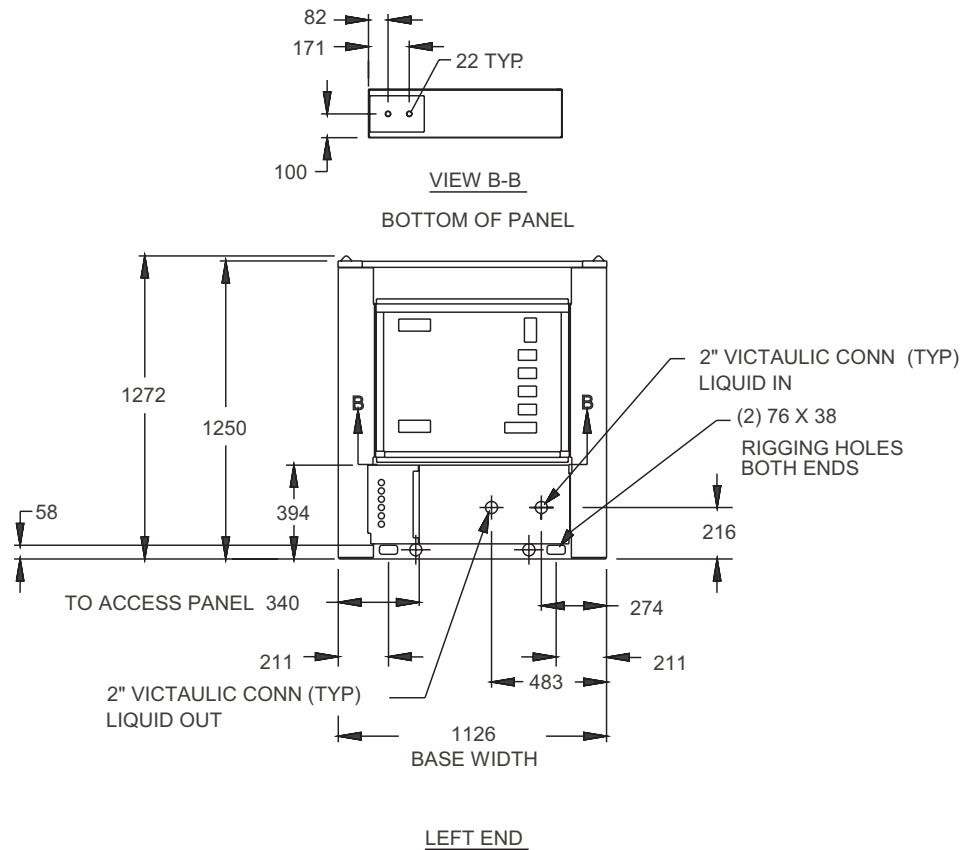

POWER: SINGLE POINT SUPPLY WITH TERMINAL BLOCK

NOTE: All dimensions are in mm unless specified otherwise.

NOTE:

Placement on a level surface of free of obstructions (including snow, for winter operation) or air circulation ensures rated performance, reliable operation, and ease of maintenance. Site restrictions may compromise minimum clearances indicated below, resulting in unpredictable airflow patterns and possible diminished performance. YORK's unit controls will optimize operation without nuisance high-pressure safety cutouts; however, the system designer must consider potential performance degradation. Recommended minimum clearances: front to wall – 2m; rear to wall – 2m; cooler end to wall – 1.2m; coil end to wall - 2m; top – no obstructions allowed; distance between adjacent units – 3m. No more than one adjacent wall may be higher than the unit. 1" nominal deflection isolators (not shown) will increase overall unit height by 152mm.

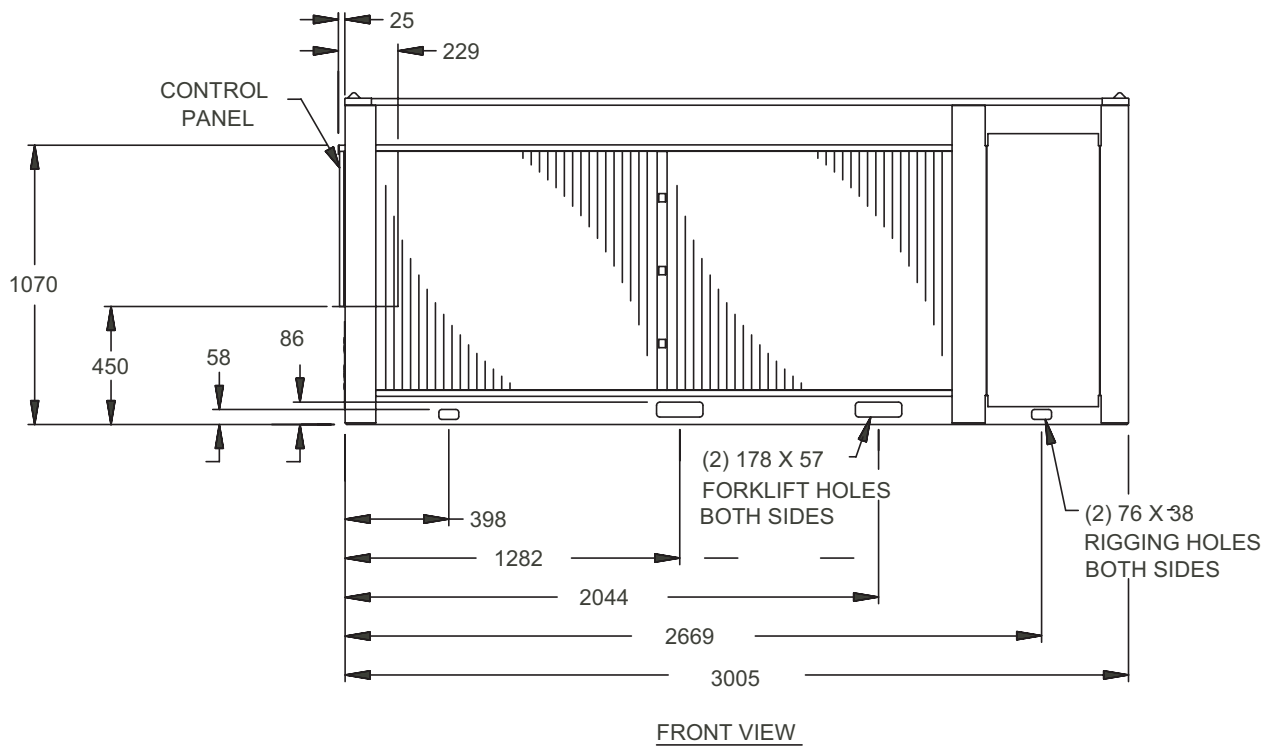
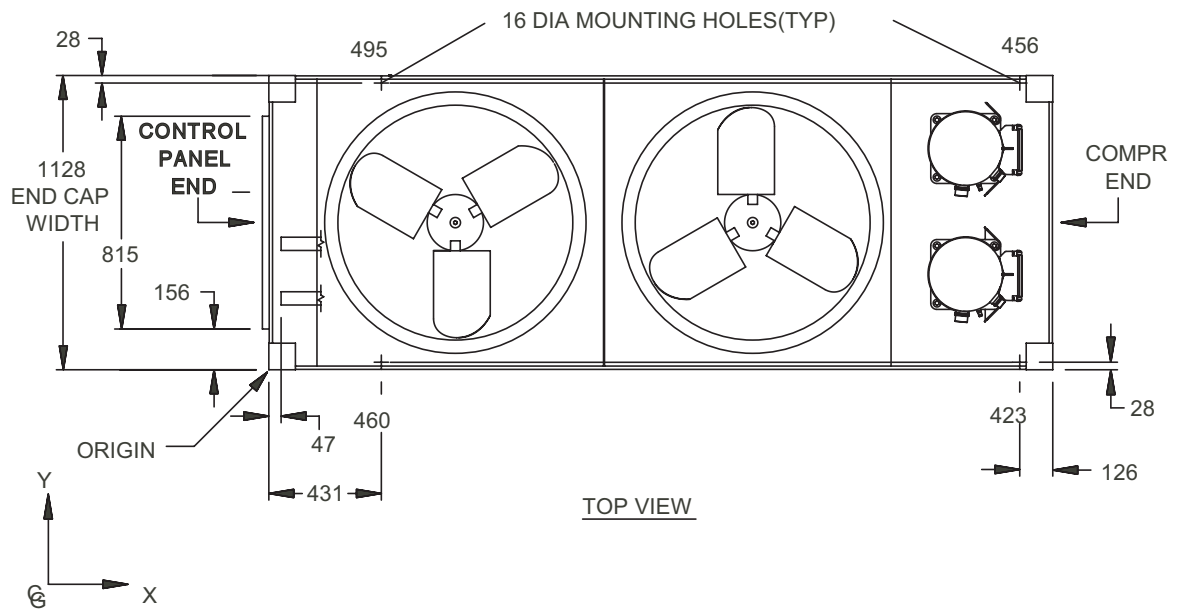

Dimensions - YCAL0033 (SI)

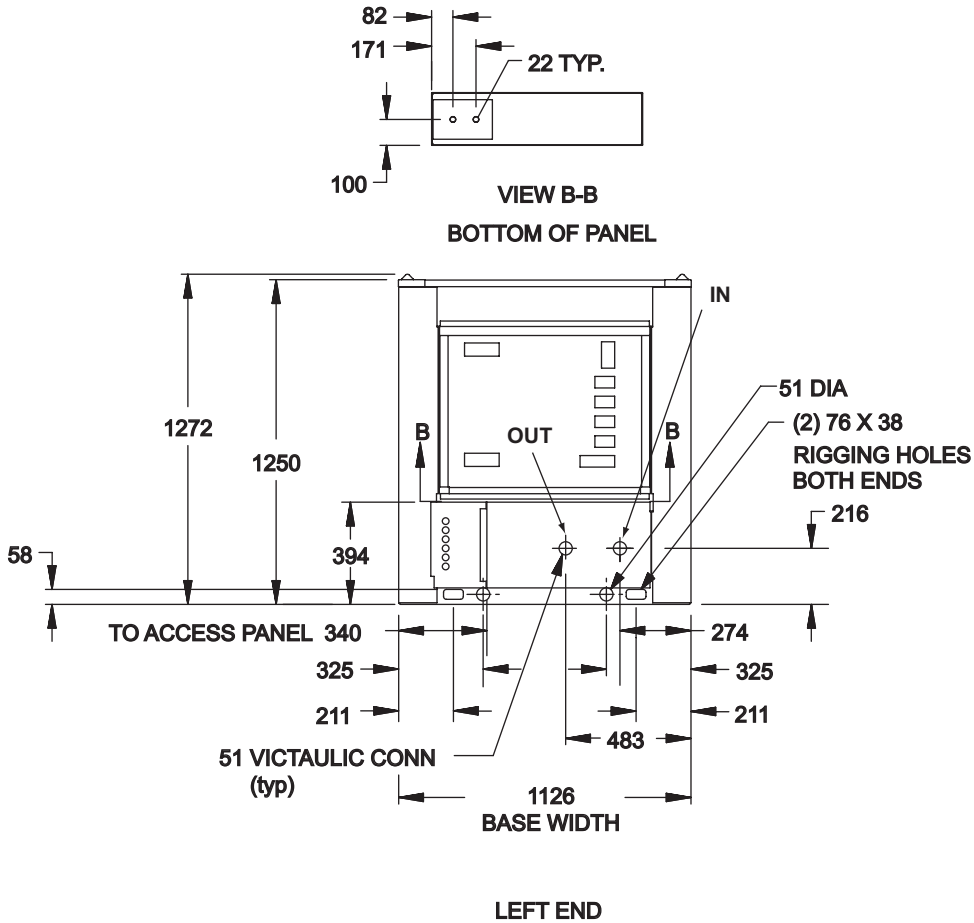

NOTE: All dimensions are in mm unless specified otherwise.

NOTE: Placement on a level surface of free of obstructions (including snow, for winter operation) or air circulation ensures rated performance, reliable operation, and ease of maintenance. Site restrictions may compromise minimum clearances indicated below, resulting in unpredictable airflow patterns and possible diminished performance. YORK's unit controls will optimize operation without nuisance high-pressure safety cutouts; however, the system designer must consider potential performance degradation. Recommended minimum clearances: front to wall - 2m; rear to wall - 2m; cooler end to wall - 1.2m; coil end to wall - 2m; top - no obstructions allowed; distance between adjacent units - 3m. No more than one adjacent wall may be higher than the unit. 1" nominal deflection isolators (not shown) will increase overall unit height by 152mm.

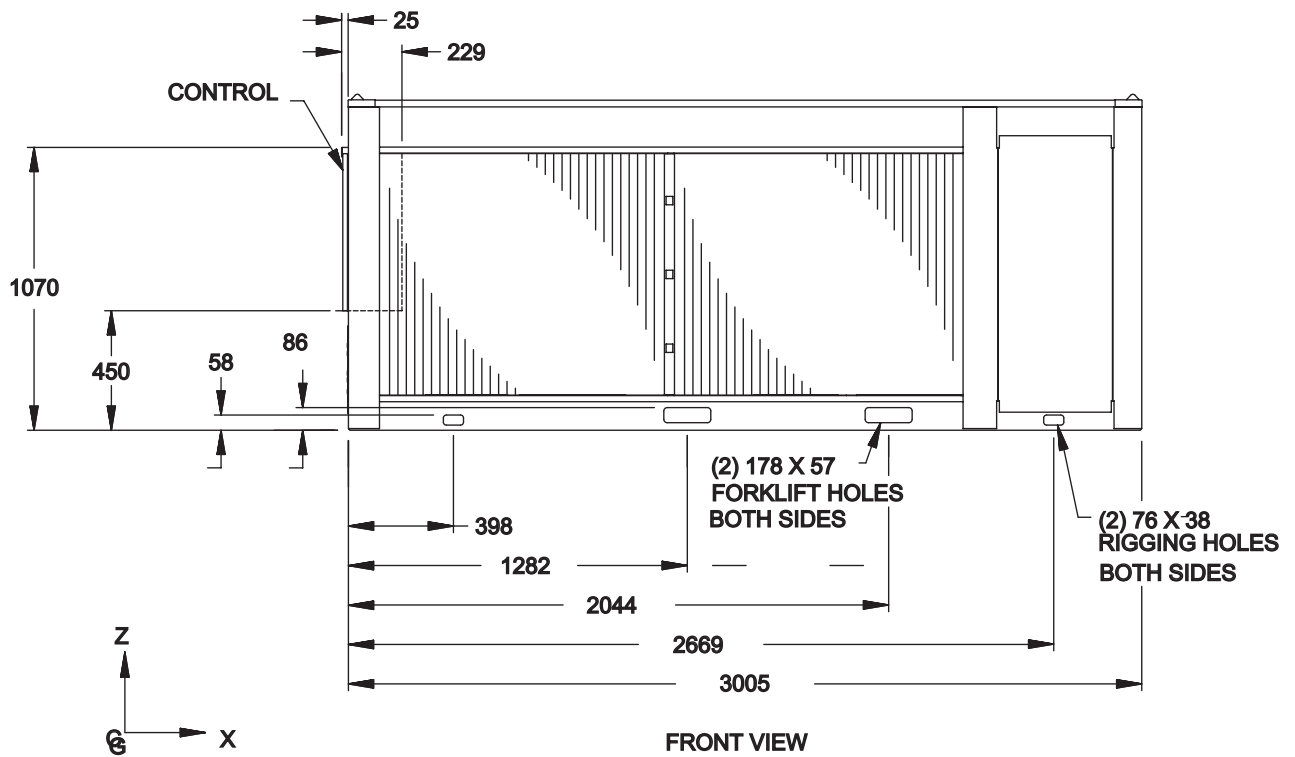
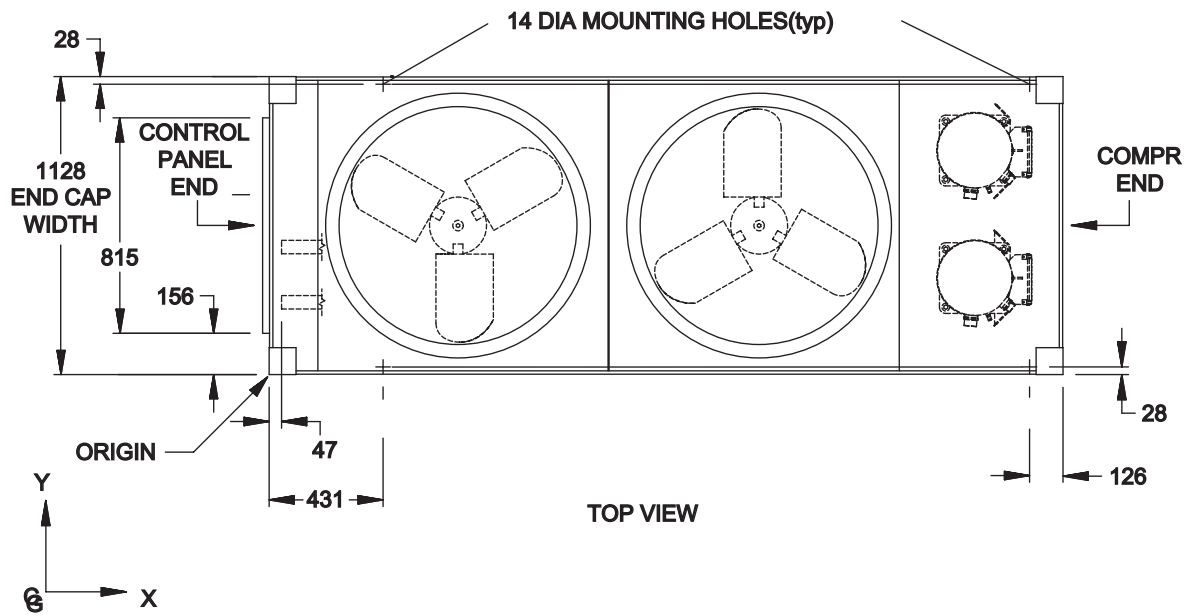

Dimensions - YCAL0043 (SI)

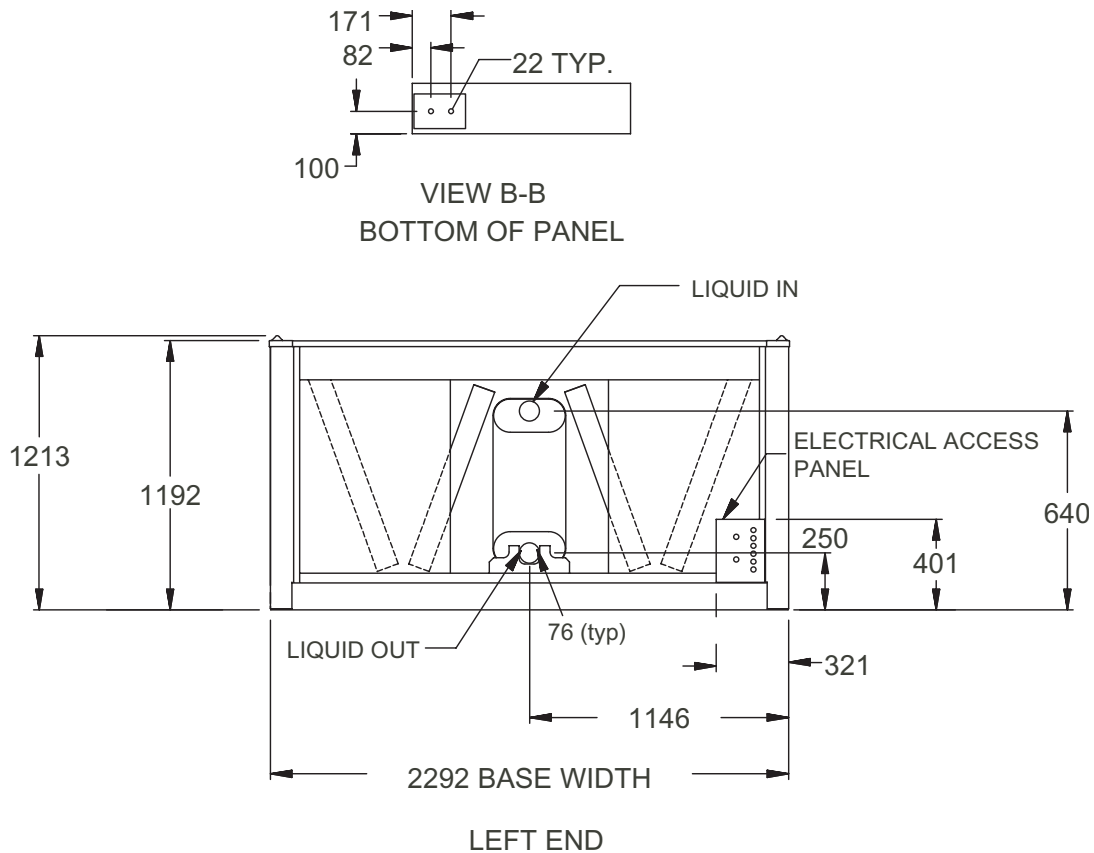

NOTE: All dimensions are in mm unless specified otherwise.

NOTE:

Placement on a level surface of free of obstructions (including snow, for winter operation) or air circulation ensures rated performance, reliable operation, and ease of maintenance. Site restrictions may compromise minimum clearances indicated below, resulting in unpredictable airflow patterns and possible diminished performance. YORK's unit controls will optimize operation without nuisance high-pressure safety cutouts; however, the system designer must consider potential performance degradation. Recommended minimum clearances: front to wall – 2m; rear to wall – 2m; cooler end to wall – 1.2m; coil end to wall – 2m; top – no obstructions allowed; distance between adjacent units – 3m. No more than one adjacent wall may be higher than the unit. 1" nominal deflection isolators (not shown) will increase overall unit height by 152mm.

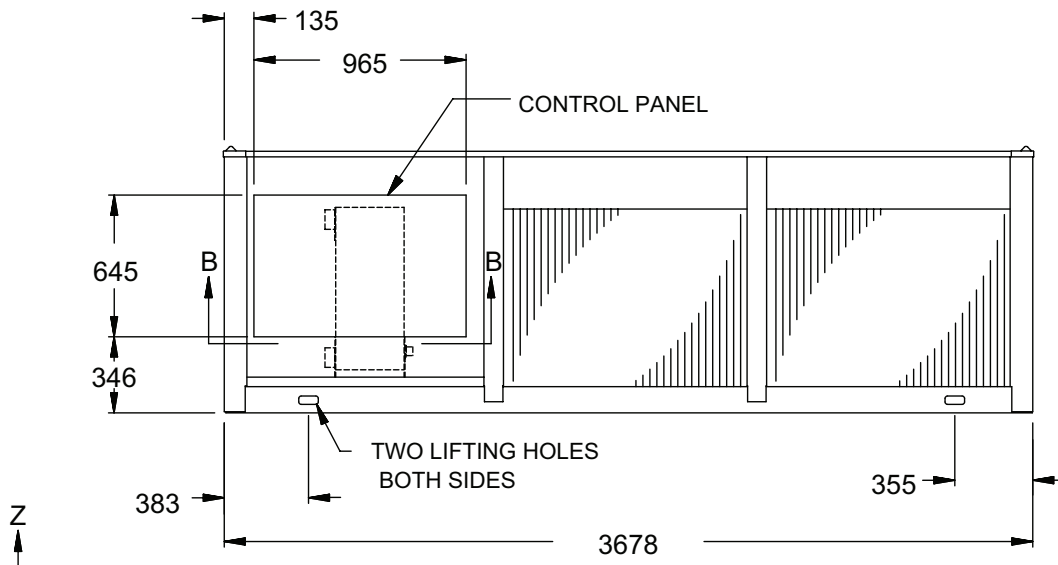
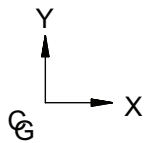
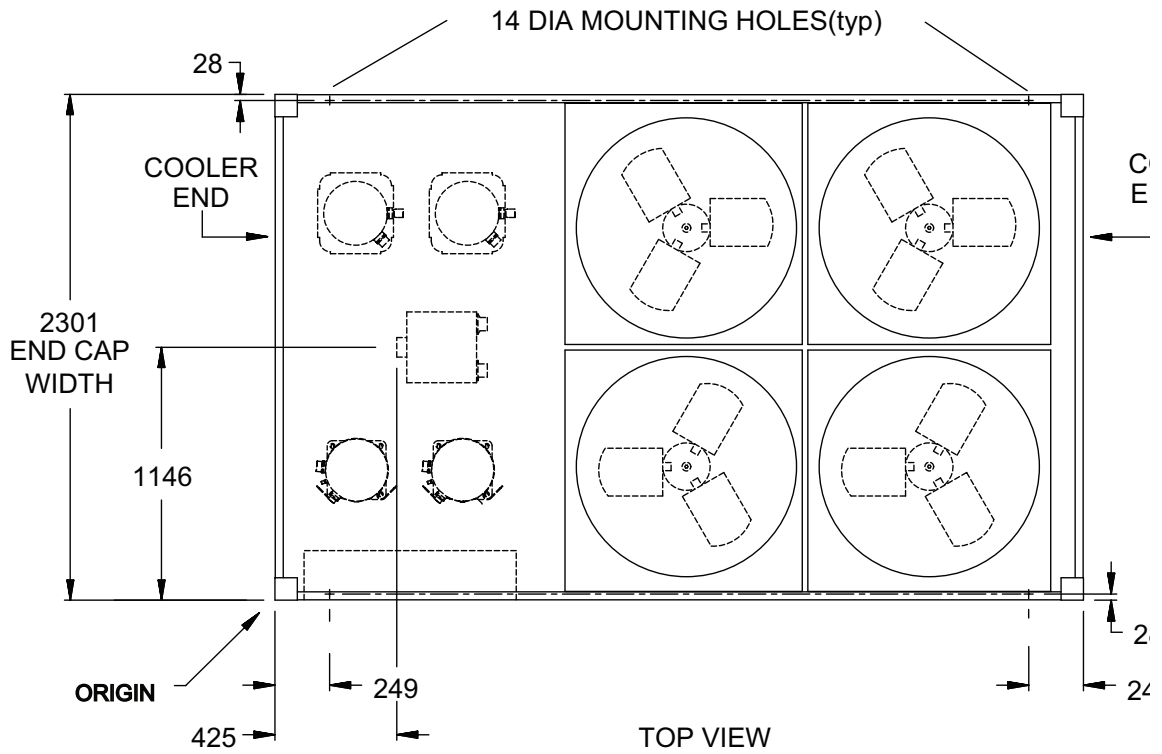

Dimensions - YCAL0046 (SI)

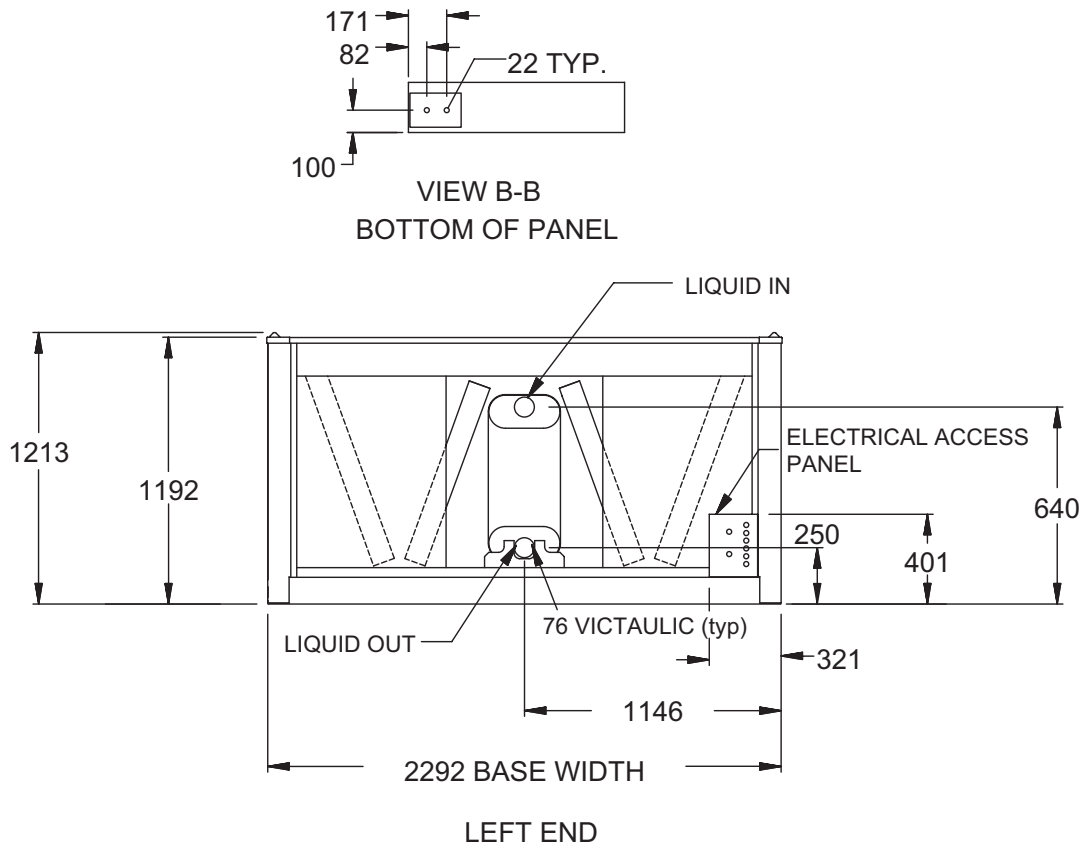

NOTE: All dimensions are in mm unless specified otherwise.

NOTE:

Placement on a level surface of free of obstructions (including snow, for winter operation) or air circulation ensures rated performance, reliable operation, and ease of maintenance. Site restrictions may compromise minimum clearances indicated below, resulting in unpredictable airflow patterns and possible diminished performance. YORK's unit controls will optimize operation without nuisance high-pressure safety cutouts; however, the system designer must consider potential performance degradation. Recommended minimum clearances: front to wall – 2m; rear to wall – 2m; cooler end to wall – 1.2m; coil end to wall - 2m; top – no obstructions allowed; distance between adjacent units – 3m. No more than one adjacent wall may be higher than the unit. 1" nominal deflection isolators (not shown) will increase overall unit height by 152mm.

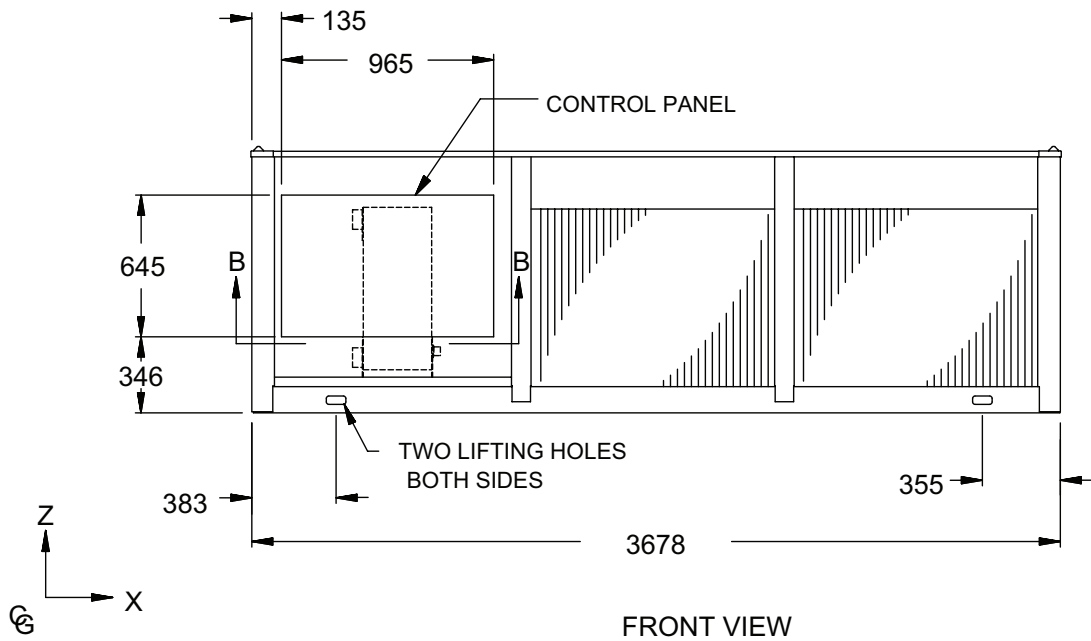
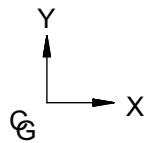
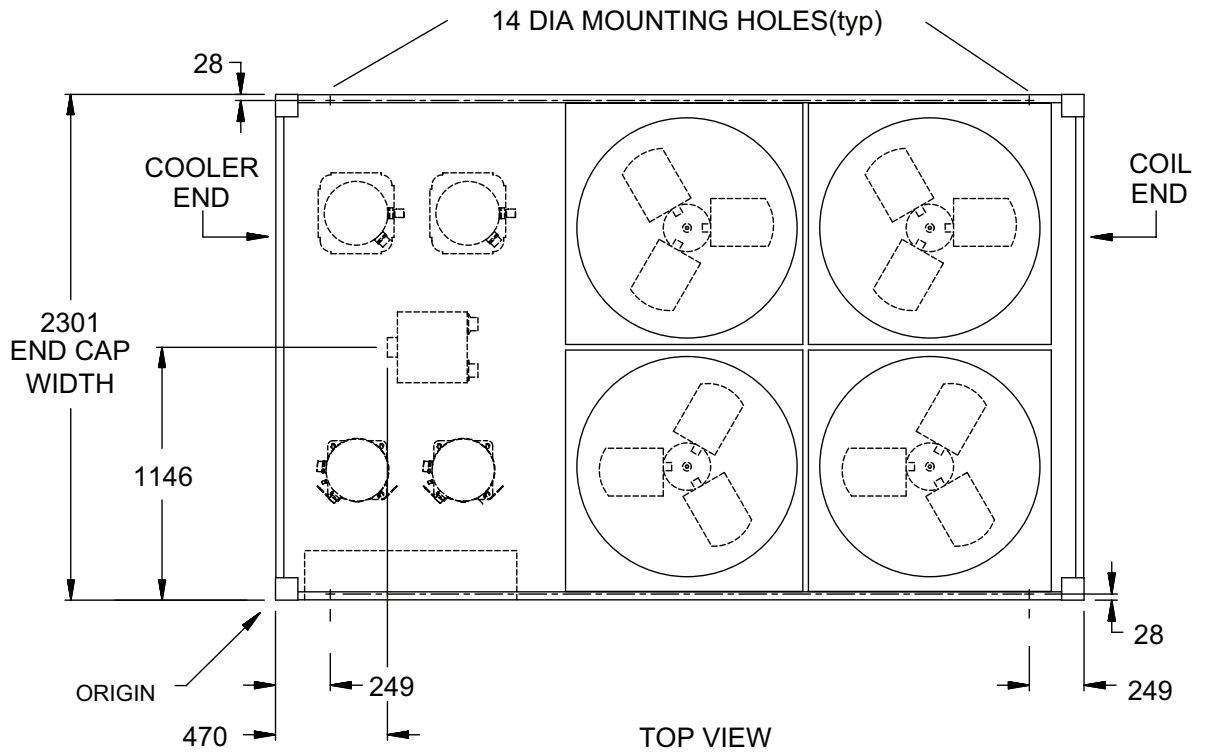

Dimensions - YCAL0052 (SI)

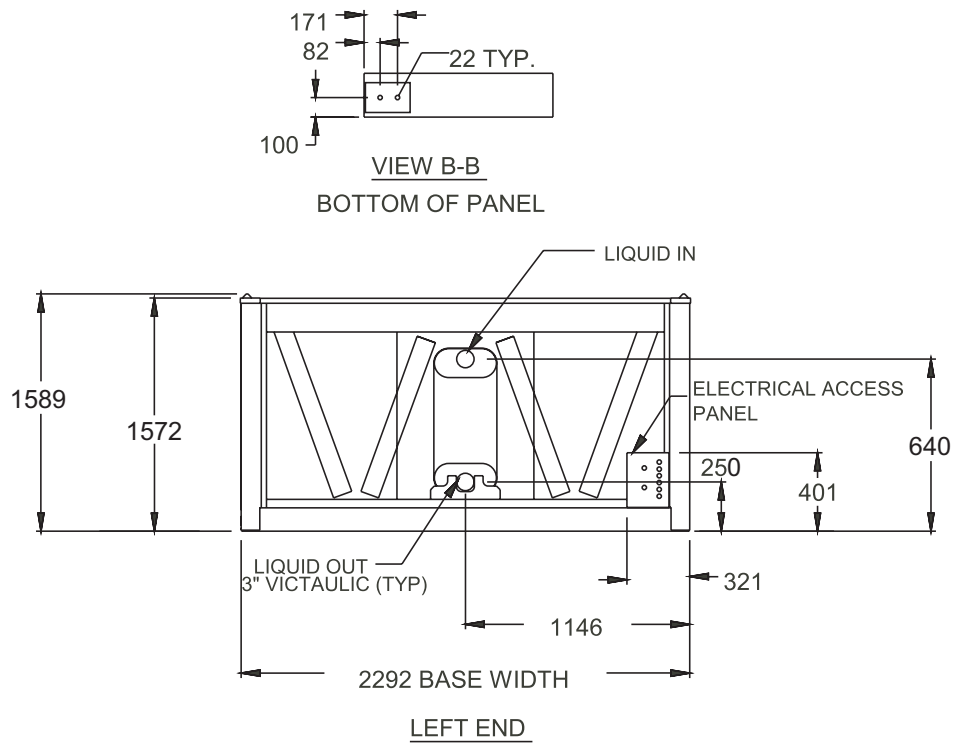

POWER: SINGLE POINT SUPPLY WITH TERMINAL BLOCK

NOTE: All dimensions are in mm unless specified otherwise.

NOTE:

Placement on a level surface of free of obstructions (including snow, for winter operation) or air circulation ensures rated performance, reliable operation, and ease of maintenance. Site restrictions may compromise minimum clearances indicated below, resulting in unpredictable airflow patterns and possible diminished performance. YORK's unit controls will optimize operation without nuisance high-pressure safety cutouts; however, the system designer must consider potential performance degradation. Recommended minimum clearances: front to wall – 2m; rear to wall – 2m; cooler end to wall – 1.2m; coil end to wall - 2m; top – no obstructions allowed; distance between adjacent units – 3m. No more than one adjacent wall may be higher than the unit. 1" nominal deflection isolators (not shown) will increase overall unit height by 152mm.

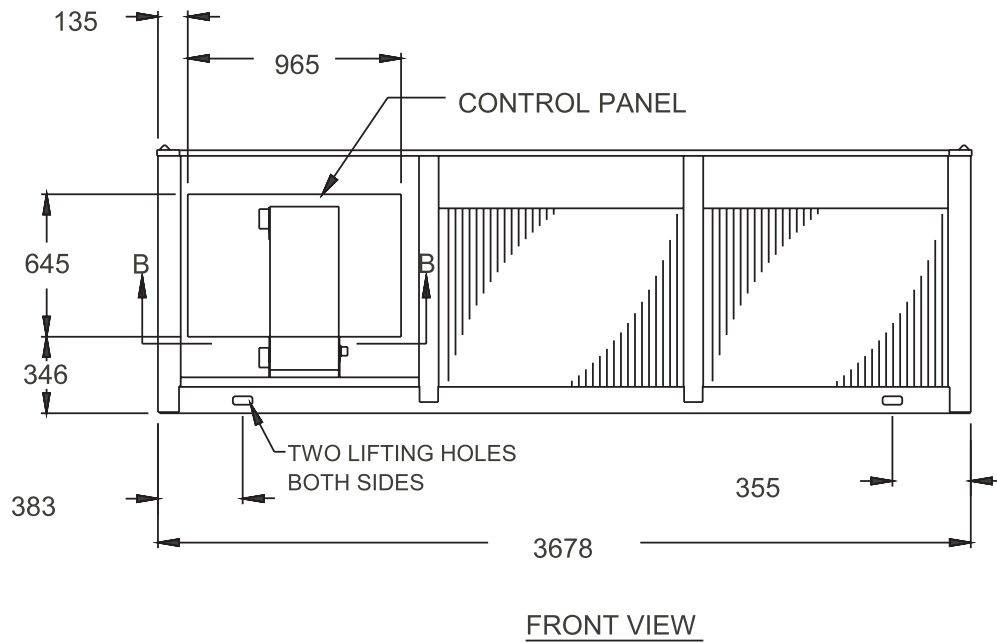
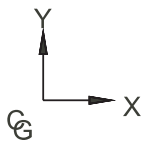
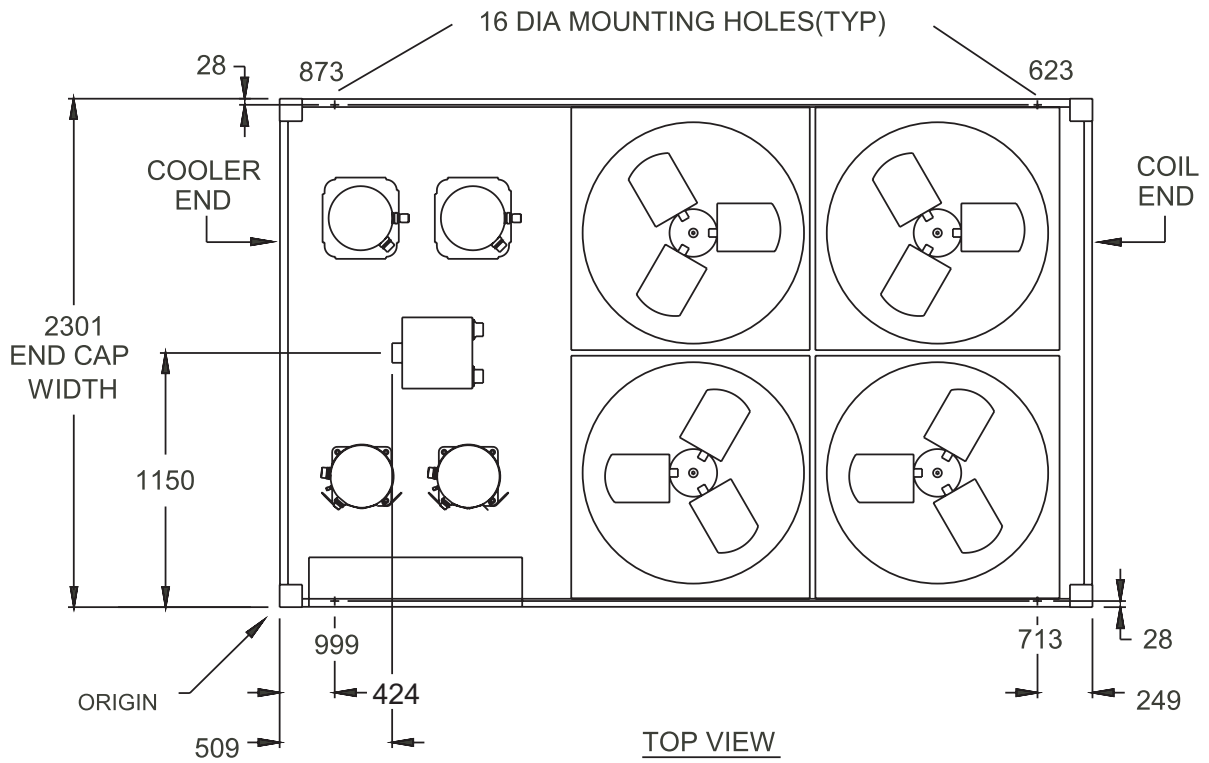

Dimensions - YCAL0056 (SI)

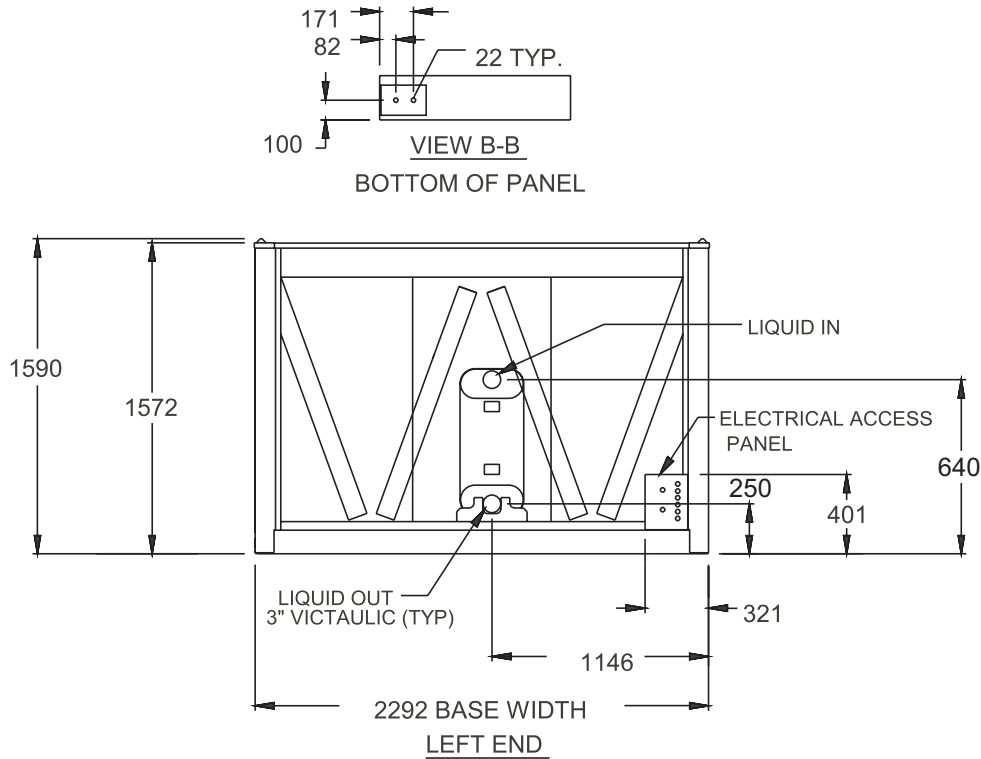

POWER: SINGLE POINT SUPPLY WITH TERMINAL BLOCK

NOTE: All dimensions are in mm unless specified otherwise.

NOTE:

Placement on a level surface of free of obstructions (including snow, for winter operation) or air circulation ensures rated performance, reliable operation, and ease of maintenance. Site restrictions may compromise minimum clearances indicated below, resulting in unpredictable airflow patterns and possible diminished performance. YORK's unit controls will optimize operation without nuisance high-pressure safety cutouts; however, the system designer must consider potential performance degradation. Recommended minimum clearances: front to wall – 2m; rear to wall – 2m; cooler end to wall – 1.2m; coil end to wall - 2m; top – no obstructions allowed; distance between adjacent units – 3m. No more than one adjacent wall may be higher than the unit. 1" nominal deflection isolators (not shown) will increase overall unit height by 152mm.

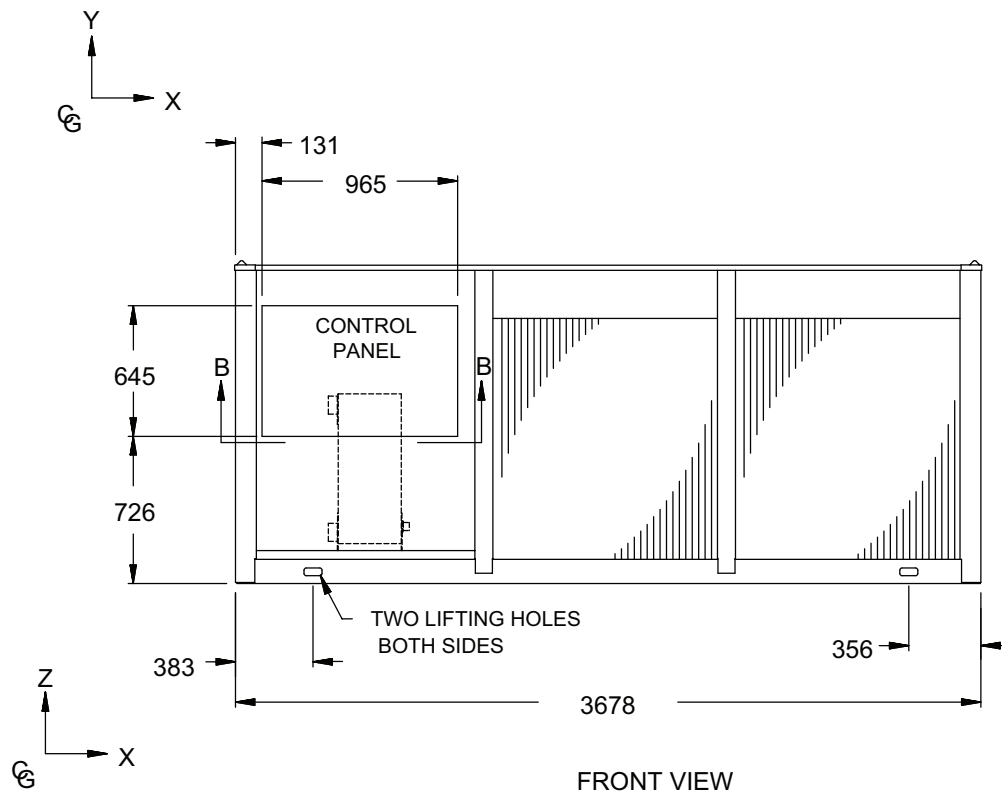
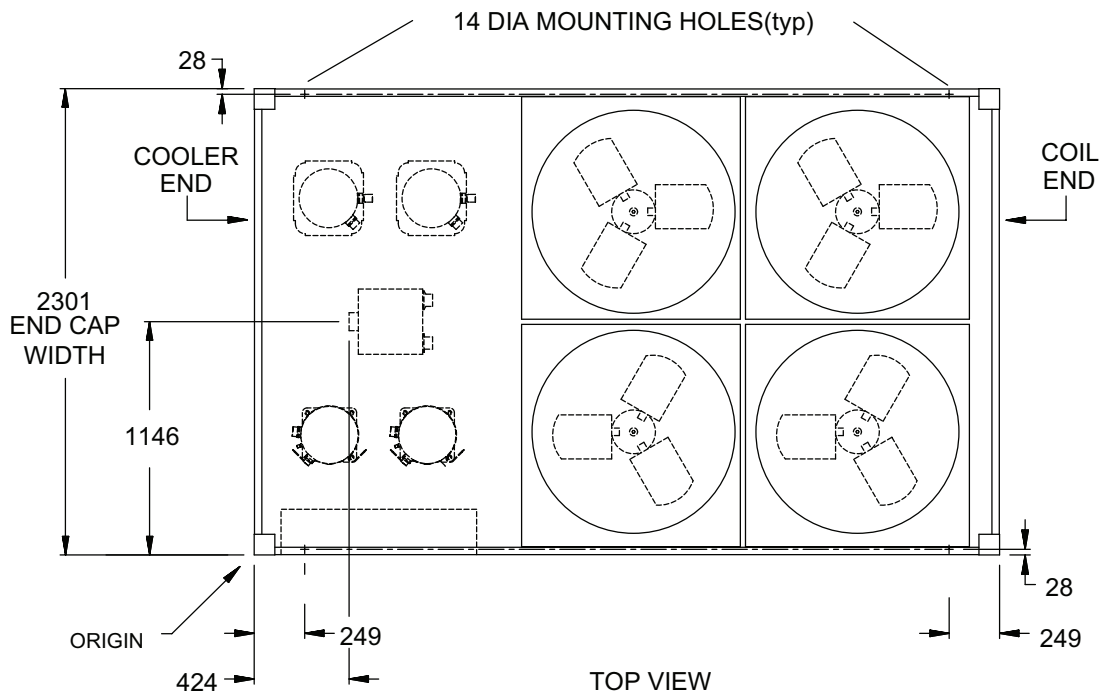

Dimensions - YCAL0066 (SI)

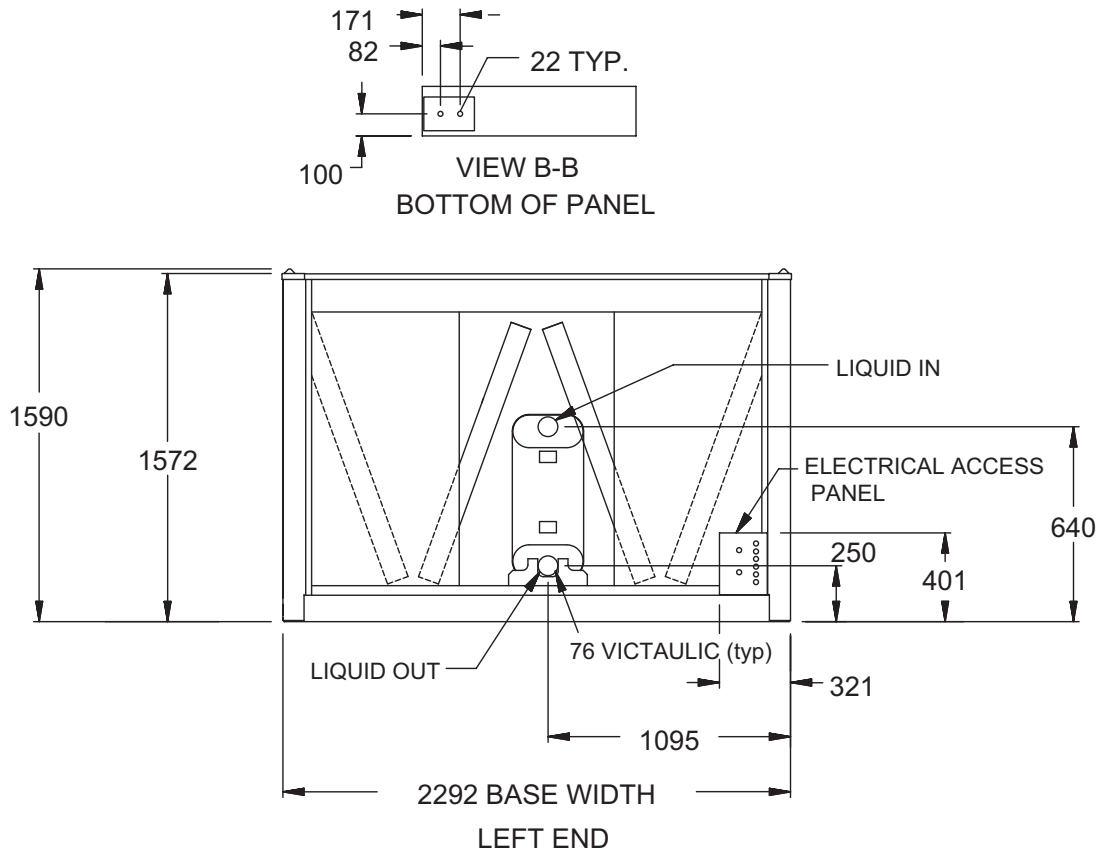

NOTE: All dimensions are in mm unless specified otherwise.

NOTE:

Placement on a level surface of free of obstructions (including snow, for winter operation) or air circulation ensures rated performance, reliable operation, and ease of maintenance. Site restrictions may compromise minimum clearances indicated below, resulting in unpredictable airflow patterns and possible diminished performance. YORK's unit controls will optimize operation without nuisance high-pressure safety cutouts; however, the system designer must consider potential performance degradation. Recommended minimum clearances: front to wall – 2m; rear to wall – 2m; cooler end to wall – 1.2m; coil end to wall - 2m; top – no obstructions allowed; distance between adjacent units – 3m. No more than one adjacent wall may be higher than the unit. 1" nominal deflection isolators (not shown) will increase overall unit height by 152mm.

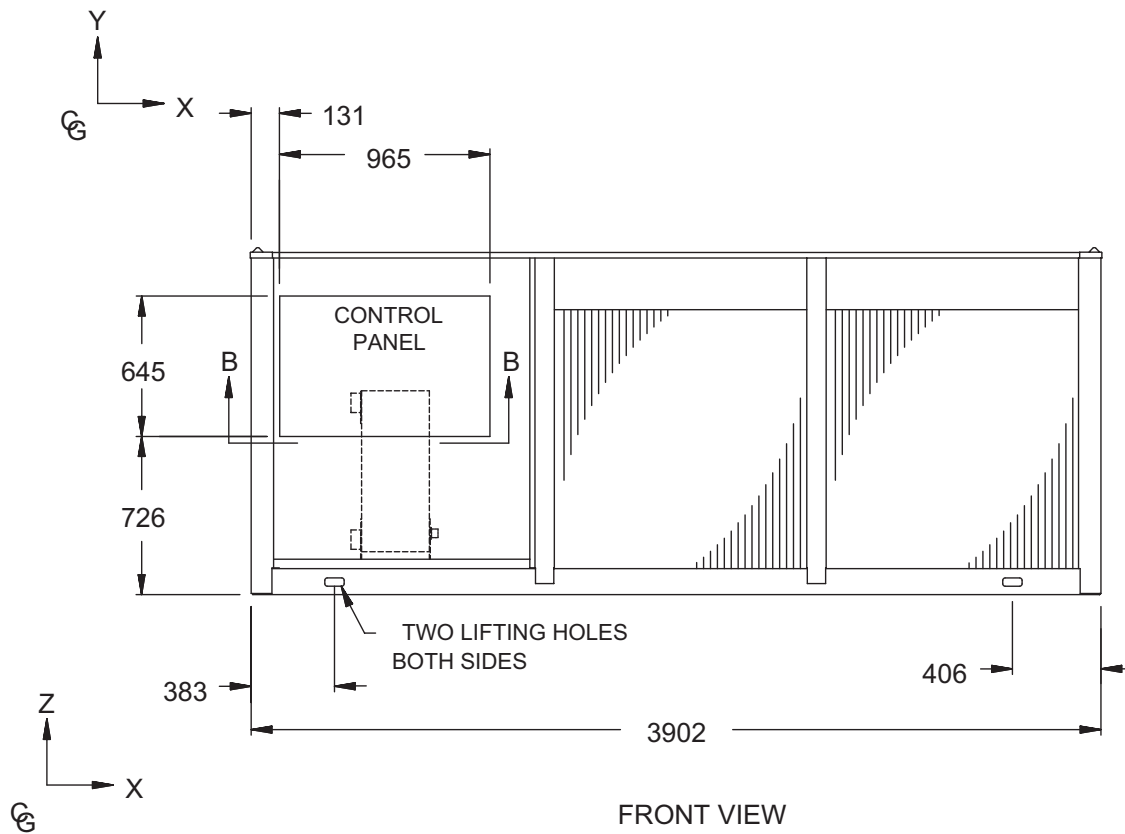
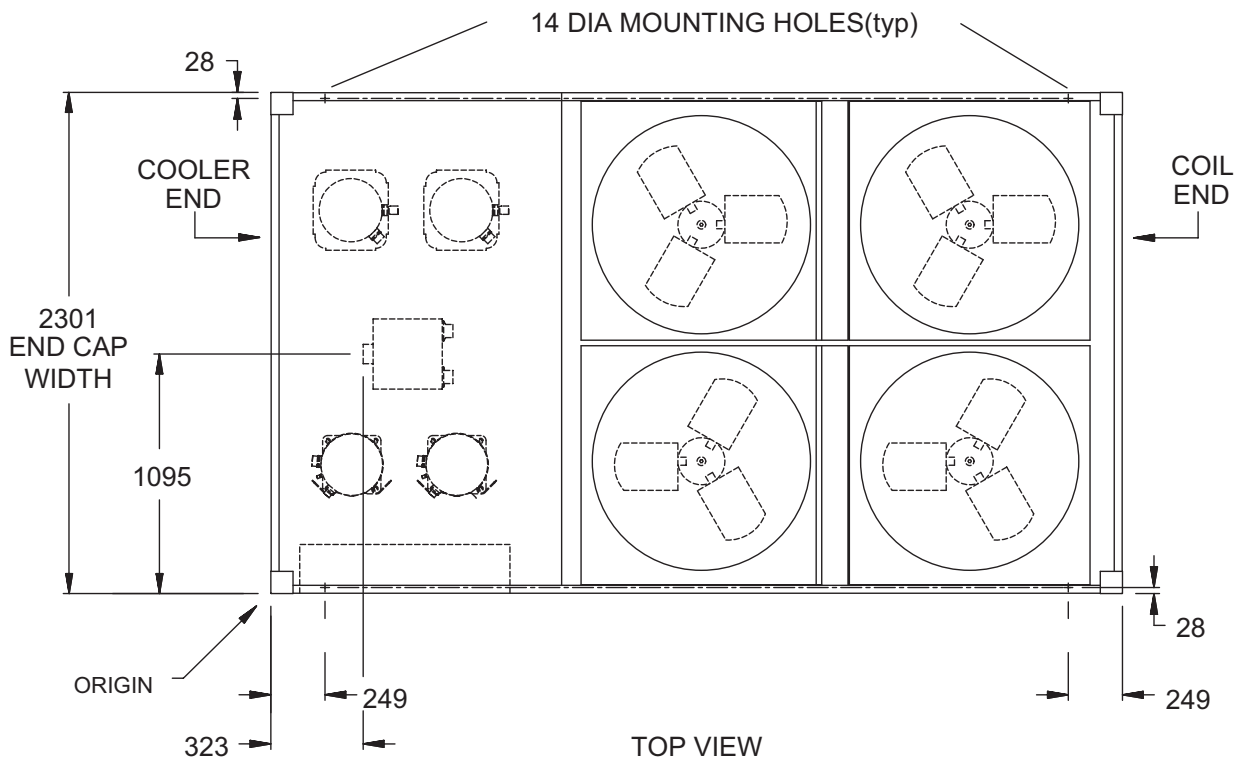

ONE INCH DEFLECTION SPRING ISOLATOR CROSS-REFERENCE

CPX-X-

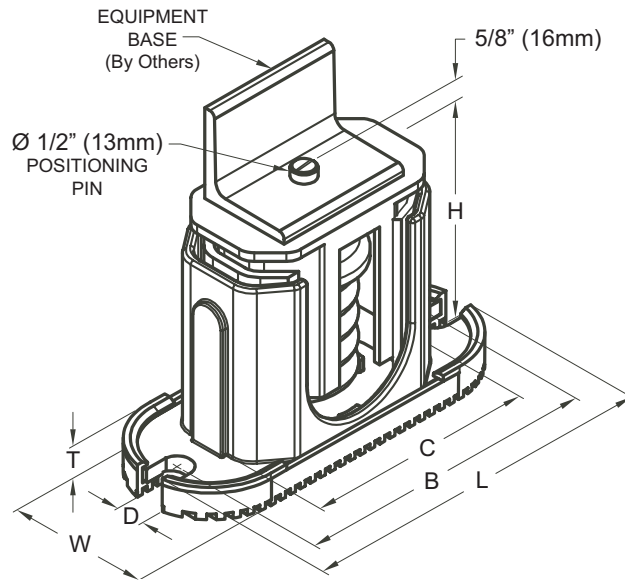

MOUNT TYPE	DIMENSION DATA (INCHES)						
	W	D	L	B	C	T	H
CP	3	5/8	7-3/4	6-1/2	4-3/4	1/2	5-5/8
C2P	3	5/8	10-1/2	9-1/4	7-3/4	9/16	6
SI (mm)							
CP	75	16	197	165	121	13	143
C2P	75	16	267	235	197	14	152

MODEL NUMBER	COLOR CODE	RATED CAPACITY (FOR UNITS WITH ALL LOAD POINTS LESS THAN 1785 LBS (810 KG))	
		(LBS.)	(KG)
CP-1D-510	BLACK	Up thru 434	Up thru 197
CP-1D-900	DARK GREEN	435 thru 765	198 thru 347
CP-1D-1200	GRAY	766 thru 1020	348 thru 463
CP-1D-1360	WHITE	1021 thru 1156	464 thru 524
CP-1D-1785N	GRAY/RED	1157 thru 1785	525 thru 810

MODEL NUMBER	COLOR CODE	RATED CAPACITY (FOR UNITS WITH ANY LOAD POINT ABOVE 1518 LBS (689 KG))	
		(LBS.)	(KG)
C2P-1D-1350	DARK PURPLE	Up thru 1148	Up to 521
C2P-1D-1800	DARK GREEN	1149 thru 1530	522 - 694
C2P-1D-2400	GRAY	1531 thru 2040	695 - 925
C2P-1D-2400	GRAY	1531 thru 2040	695 - 925
C2P-1D-2720	WHITE	2041 thru 2312	926 - 1049
C2P-1D-3570N	GRAY/RED	2313 thru 3570	1050 - 1619

NEOPRENE ISOLATOR CROSS-REFERENCE

RD- 1, 2, and 3 Isolators

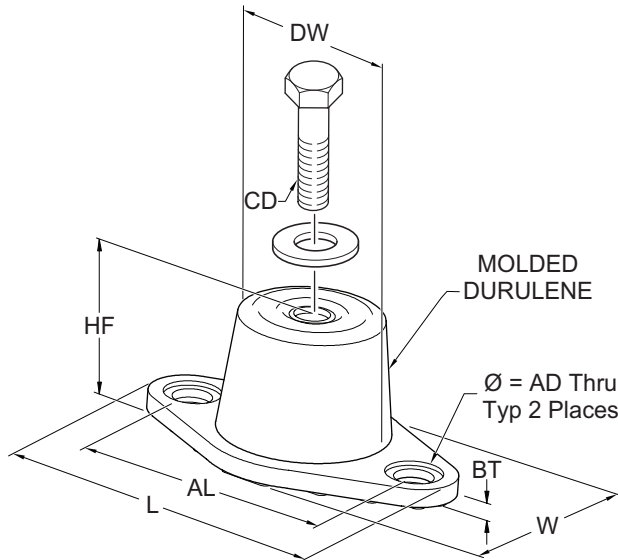

RD-4 Isolators

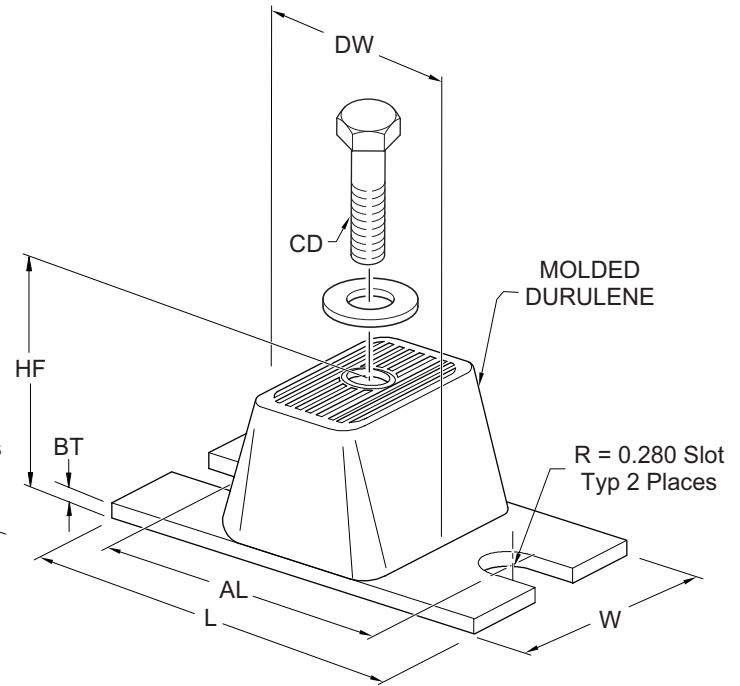

LD17304

MOUNT TYPE	DIMENSION DATA (INCHES)							
	L	W	HF	AL	AD	BT	CD	DW
RD1-WR	3.13	1.75	1.25	2.38	0.34	0.19	5/16-18 UNC X 3/4	1.25
RD2-WR	3.88	2.38	1.75	3	0.34	0.22	3/8-16 UNC X 1	1.75
RD3-WR	5.5	3.38	2.88	4.13	0.56	0.25	1/2-13 UNC X 1	2.5
RD4-WR	6.25	4.63	2.75	5	0.56	0.38	1/2-13 UNC X 1	3
DIMENSION DATA (MM)								
RD1-WR	80	44	32	60	9	5	5/16-18 UNC X 3/4	32
RD2-WR	99	60	44	76	9	6	3/8-16 UNC X 1	44
RD3-WR	140	86	73	105	14	6	1/2-13 UNC X 1	64
RD4-WR	159	118	70	127	14	10	1/2-13 UNC X 1	76

MODEL NUMBER	RATED CAPACITY (LBS)	RATED DEFLECTION (IN)	DURO (± 5)
RD2-Light Blue-WR	35	0.4	30
RD2-Brown-WR	45	0.4	40
RD2-Brick Red-WR	70	0.4	50
RD 2-Lime-WR	120	0.4	60
MODEL NUMBER	RATED CAPACITY (LBS)	RATED DEFLECTION (IN)	DURO (± 5)
RD2-Light Blue-WR	135	0.5	30
RD2-Brown-WR	170	0.5	40
RD2-Brick Red-WR	240	0.5	50
RD 2-Lime-WR	380	0.5	60
RD2 Charcoal-WR	550	0.5	70

MODEL NUMBER	RATED CAPACITY (LBS)	RATED DEFLECTION (IN)	DURO (± 5)
RD3-Brown-WR	250	0.5	40
RD3-Brick Red-WR	525	0.5	50
RD3-Lime-WR	750	0.5	60
RD3-Charcoal-WR	1100	0.5	70
MODEL NUMBER	RATED CAPACITY (LBS)	RATED DEFLECTION (IN)	DURO (± 5)
RD4-Brown-WR	1500	0.5	40
RD4-Brick Red-WR	2250	0.5	50
RD4-Lime-WR	3000	0.5	60
RD4-Charcoal-WR	4000	0.5	70

TWO INCH DEFLECTION, SEISMIC SPRING ISOLATOR CROSS-REFERENCE

Y2RS

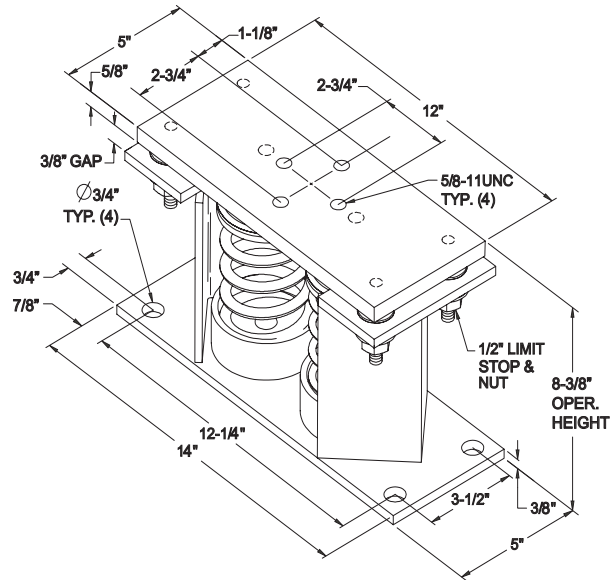

MODEL NUMBER	ISOLATOR COLOR	WEIGHT RANGE (LBS)	WEIGHT RANGE (KGS)
Y2RSI-2D-460	GREEN	Up thru 391	UP TO 177
Y2RSI-2D-710	DARK BROWN	392 thru 604	178 - 274
Y2RSI-2D-870	RED	605 thru 740	275 - 336
Y2RSI-2D-1200N	RED/BLACK	741 thru 1020	337 - 463
Y2RSI-2D-1690	PINK	1021 thru 1437	464 - 652
Y2RSI-2D-2640N	PINK/GRAY	1438 thru 2244	653 - 1018
Y2RSI-2D-2870N	PINK/GRAY/ORANGE	2245 thru 2618	1019 - 1188
Y2RSI-2D-3280N	PINK/GRAY/DK.BROWN	2619 thru 3740	1189 - 1696

INTENTIONALLY LEFT BLANK

Electrical Data - 50 & 60Hz

YCAL0019 - YCAL0066

WIRING WITHOUT PUMP

CHILLER MODEL YCAL	VOLT	HZ	MIN CIRCUIT AMPS MCA	MIN N/F DISC SW MDSW	MIN DUAL ELEM FUSE	MAX DUAL ELEM FUSE MAX CB	SYSTEM # 1						SYSTEM # 2							
							COMPR 1		COMPR 2		FAN		COMPR 1		COMPR 2		FAN			
							RLA	LRA	RLA	LRA	QTY	FLA	LRA	RLA	LRA	RLA	LRA	QTY	FLA	LRA
0019	200	60	101	150	125	125	42.2	250	42.2	250	2	2.6	5.0	-	-	-	-	-	-	
	230	60	94	100	110	125	39.0	250	39.0	250	2	2.6	5.0	-	-	-	-	-	-	
	380	60	54	60	60	70	22.5	155	22.5	155	2	1.6	3.0	-	-	-	-	-	-	
	400	50	45	60	50	60	18.6	114	18.6	114	2	1.3	2.5	-	-	-	-	-	-	
	460	60	45	60	50	60	18.6	114	18.6	114	2	1.3	2.5	-	-	-	-	-	-	
	575	60	36	60	40	50	14.9	100	14.9	100	2	1.0	2.0	-	-	-	-	-	-	
	400	50	45	60	50	60	18.6	114	18.6	114	2	1.3	2.5	-	-	-	-	-	-	
0022	200	60	108	150	125	150	45.4	250	45.4	250	2	2.6	5.0	-	-	-	-	-	-	
	230	60	100	150	125	125	42.0	250	42.0	250	2	2.6	5.0	-	-	-	-	-	-	
	380	60	58	60	70	80	24.2	155	24.2	155	2	1.6	3.0	-	-	-	-	-	-	
	400	50	48	60	60	60	20.0	125	20.0	125	2	1.3	2.5	-	-	-	-	-	-	
	460	60	48	60	60	60	20.0	125	20.0	125	2	1.3	2.5	-	-	-	-	-	-	
	575	60	39	60	45	50	16.0	100	16.0	100	2	1.0	2.0	-	-	-	-	-	-	
	400	50	48	60	60	60	20.0	125	20.0	125	2	1.3	2.5	-	-	-	-	-	-	
0028	200	60	136	150	175	175	51.3	300	55.8	425	2	7.6	44.0	-	-	-	-	-	-	
	230	60	136	150	150	175	51.3	300	55.8	425	2	7.4	19.1	-	-	-	-	-	-	
	380	60	81	100	90	110	26.9	139	36.0	239	2	4.5	23.1	-	-	-	-	-	-	
	460	60	65	100	80	90	23.1	150	26.9	187	2	4.0	19.0	-	-	-	-	-	-	
	575	60	55	60	70	70	19.9	109	23.7	148	2	2.9	15.3	-	-	-	-	-	-	
	400	50	58	100	70	80	21.8	140	23.7	198	2	3.4	17.5	-	-	-	-	-	-	
0033	200	60	151	200	175	200	59.9	425	59.9	425	2	7.6	30.9	-	-	-	-	-	-	
	230	60	140	150	175	175	55.5	425	55.5	425	2	7.4	37.0	-	-	-	-	-	-	
	380	60	81	100	90	110	32.0	239	32.0	239	2	4.5	22.3	-	-	-	-	-	-	
	400	50	68	100	80	90	26.4	198	26.4	198	2	4.0	19.0	-	-	-	-	-	-	
	460	60	67	100	80	90	26.4	187	26.4	187	2	3.4	17.2	-	-	-	-	-	-	
	575	60	54	60	60	70	21.1	148	21.1	148	2	2.9	14.6	-	-	-	-	-	-	
	400	50	68	100	80	90	26.4	198	26.4	198	2	4.0	19.0	-	-	-	-	-	-	
0043	200	60	224	250	250	250	45.4	250	45.4	250	2	7.6	30.9	45.4	250	45.4	250	2	7.6	30.9
	230	60	209	250	225	250	42.0	250	42.0	250	2	7.4	37.0	42.0	250	42.0	250	2	7.4	37.0
	380	60	121	150	150	150	24.2	155	24.2	155	2	4.5	22.3	24.2	155	24.2	155	2	4.5	22.3
	400	50	102	150	110	110	20.0	125	20.0	125	2	4.0	19.0	20.0	125	20.0	125	2	4.0	19.0
	460	60	99	150	110	110	20.0	125	20.0	125	2	3.4	17.2	20.0	125	20.0	125	2	3.4	17.2
	575	60	80	100	90	90	16.0	100	16.0	100	2	2.9	14.6	16.0	100	16.0	100	2	2.9	14.6
	400	50	102	150	110	110	20.0	125	20.0	125	2	4.0	19.0	20.0	125	20.0	125	2	4.0	19.0
0046	200	60	228	250	250	250	47.0	250	47.0	250	2	7.6	30.9	45.4	250	45.4	250	2	7.6	30.9
	230	60	212	250	225	250	43.5	250	43.5	250	2	7.4	37.0	42.0	250	42.0	250	2	7.4	37.0
	380	60	123	150	150	150	25.1	155	25.1	155	2	4.5	22.3	24.2	155	24.2	155	2	4.5	22.3
	400	50	103	150	110	110	20.7	125	20.7	125	2	4.0	19.0	20.0	125	20.0	125	2	4.0	19.0
	460	60	101	150	110	110	20.7	125	20.7	125	2	3.4	17.2	20.0	125	20.0	125	2	3.4	17.2
	575	60	81	100	90	90	16.6	100	16.6	100	2	2.9	14.6	16.0	100	16.0	100	2	2.9	14.6
	400	50	103	150	110	110	20.7	125	20.7	125	2	4.0	19.0	20.0	125	20.0	125	2	4.0	19.0

See Notes on page 85.

MODEL YCAL	VOLT	HZ	MIN CIRCUIT AMPS MCA	MIN N/F DISC SW MDSW	MIN DUAL ELEM FUSE	MAX DUAL ELEM FUSE MAX CB	SYSTEM # 1						SYSTEM # 2							
							COMPR 1		COMPR 2		FAN		COMPR 1		COMPR 2		FAN			
							RLA	LRA	RLA	LRA	QTY	FLA	LRA	RLA	LRA	RLA	LRA	QTY	FLA	LRA
0052	200	60	248	400	300	300	51.3	300	51.3	300	2	7.6	44.0	51.3	300	51.3	300	2	7.6	44.0
	230	60	248	400	300	300	51.3	300	51.3	300	2	7.4	19.1	51.3	300	51.3	300	2	7.4	19.1
	380	60	132	150	150	150	26.9	139	26.9	139	2	4.5	23.1	26.9	139	26.9	139	2	4.5	23.1
	460	60	114	150	125	125	23.1	150	23.1	150	2	4.0	19.0	23.1	150	23.1	150	2	4.0	19.0
	575	60	96	150	110	110	19.9	109	19.9	109	2	2.9	15.3	19.9	109	19.9	109	2	2.9	15.3
	400	50	106	150	125	125	21.8	140	21.8	140	2	3.4	17.5	21.8	140	21.8	140	2	3.4	17.5
0056	200	60	268	400	300	300	55.8	425	55.8	425	2	7.6	44.0	55.8	425	55.8	425	2	7.6	44.0
	230	60	267	400	300	300	55.8	425	55.8	425	2	7.4	19.1	55.8	425	55.8	425	2	7.4	19.1
	380	60	171	200	200	200	36.0	239	36.0	239	2	4.5	23.1	36.0	239	36.0	239	2	4.5	23.1
	460	60	130	150	150	150	26.9	187	26.9	187	2	4.0	19.0	26.9	187	26.9	187	2	4.0	19.0
	575	60	112	150	125	125	23.7	148	23.7	148	2	2.9	15.3	23.7	148	23.7	148	2	2.9	15.3
	400	50	114	150	125	125	23.7	198	23.7	198	2	3.4	17.5	23.7	198	23.7	198	2	3.4	17.5
0066	200	60	324	400	350	400	76.9	505	76.9	505	2	7.6	30.9	59.9	425	59.9	425	2	7.6	30.9
	230	60	301	400	350	350	71.2	505	71.2	505	2	7.4	37.0	55.5	425	55.5	425	2	7.4	37.0
	380	60	175	200	200	200	41.1	280	41.1	280	2	4.5	22.3	32.0	239	32.0	239	2	4.5	22.3
	400	50	146	200	175	175	33.9	225	33.9	225	2	4.0	19.0	26.4	198	26.4	198	2	4.0	19.0
	460	60	143	200	175	175	33.9	225	33.9	225	2	3.4	17.2	26.4	187	26.4	187	2	3.4	17.2
	575	60	115	150	125	125	27.1	180	27.1	180	2	2.9	14.6	21.1	148	21.1	148	2	2.9	14.6
	400	50	146	200	175	175	33.9	225	33.9	225	2	4.0	19.0	26.4	198	26.4	198	2	4.0	19.0

Electrical Notes

UNIT VOLTAGE	UNIT VOLTAGE	CONTROL POWER	MCA NOTE A	OVER CURRENT PROTECTION, SEE NOTE B		NF DISC Sw
				MIN	MAX	
MODELS w/o CONTROL TRANS		115-1-60/50	15A	10A	15A	30 A / 240V
MODELS w/ CONTROL TRANS	-17	200-1-60	15A	10A	15A	30 A / 240V
	-28	230-1-60	15A	10A	15A	30 A / 240V
	-40	380-1-60	15A	10A	15A	30 A / 480V
	-46	460-1-60	15A	10A	15A	30 A / 480V
	-50	380/415-1-60	15A	10A	15A	30A / 415V
	-58	575-1-60	15A	10A	15A	30 A / 600V

A. Minimum #14 AWG, 75°C, Copper Recommended

B. Minimum and Maximum Over Current Protection, Dual Element Fuse or Circuit Breaker

VOLTAGE CODE	UNIT POWER	MIN.	MAX.
-17	200-3-60	180	220
-28	230-3-60	207	253
-40	380/415-3-60	342	440
-46	460-3-60	414	506
-50	380/415-3-50	342	440
-58	575-3-60	517	633

LEGEND

ACR	LINE ACROSS THE LINE START
C.B.	CIRCUIT BREAKER
D.E.	DUAL ELEMENT FUSE
DISC SW	DISCONNECT SWITCH
FACT MOUNT CB	FACTORY MOUNTED CIRCUIT BREAKER
FLA	FULL LOAD AMPS
HZ	HERTZ
MAX	MAXIMUM
MCA	MINIMUM CIRCUIT AMPACITY
MIN	MINIMUM
MIN	NF MINIMUM NON FUSED
RLA	RATED LOAD AMPS
S.P. WIRE	SINGLE POINT WIRING
UNIT MTD SERV SW	UNIT MOUNTED SERVICE (NON-FUSED DISCONNECT SWITCH)
LRA	LOCKED ROTOR AMPS

NOTES:

1. Minimum Circuit Ampacity (MCA) is based on 125% of the rated load amps for the largest motor plus 100% of the rated load amps for all other loads included in the circuit, per N.E.C. Article 430-24. If the optional Factory Mounted Control Transformer is provided, add the following MCA values to the electrical tables for the system providing power to the transformer: -17, add 2.5 amps; -28, add 2.3 amps; -40, add 1.5 amps, -46, add 1.3 amps; -58, add 1 amps.
2. The minimum recommended disconnect switch is based on 115% of the rated load amps for all loads included in the circuit, per N.E.C. Article 440.
3. Minimum fuse size is based upon 150% of the rated load amps for the largest motor plus 100% of the rated load amps for all other loads included in the circuit to avoid nuisance trips at start-up due to lock rotor amps. It is not recommended in applications where brown outs, frequent starting and stopping of the unit, and/or operation at ambient temperatures in excess of 95°F (35°C) is anticipated.
4. Maximum fuse size is based upon 225% of the rated load amps for the largest motor plus 100% of the rated load amps for all other loads included in the circuit, per N.E.C. Article 440-22.
5. Circuit breakers must be UL listed and CSA certified and maximum size is based on 225% of the rated load amps for the largest motor plus 100% of the rated load amps for all other loads included in the circuit. Otherwise, an HACR-type circuit breakers must be used. Maximum HACR circuit breaker rating is based on 225% of the rated load amps for the largest motor plus 100% of the rated load amps for all other loads included in the circuit.
6. The "INCOMING WIRE RANGE" is the minimum and maximum wire size that can be accommodated by the unit wiring lugs. The (2) preceding the wire range indicates the number of termination points available per phase of the wire range specified. Actual wire size and number of wires per phase must be determined based on the National Electrical Code, **using copper connectors only**. Field wiring must also comply with local codes.
7. A ground lug is provided for each compressor system to accommodate a field grounding conductor per N.E.C. Table 250-95. A control-circuit-grounding lug is also supplied.
8. The supplied disconnect is a "Disconnecting Means" as defined in the N.E.C. 100, and is intended for isolating the unit for the available power supply to perform maintenance and troubleshooting. This disconnect is not intended to be a Load Break Device.
9. Field Wiring by others which complies to the National Electrical Code & Local Codes.

Circuit Breaker Calculations

MAX DUAL ELEM FUSE MAX CB (MOP)
 $= 2.25 \times \text{CURRENT OF LARGEST MOTOR} + \sum (\text{REMAINING FLAS OR RLAS})$

FOR THIS NAME PLATE THE FORMULA BELOW WAS USED:
 $= 2.25 * \text{RLACPR1} + \text{RLACPR2} + \text{RLACPR3} + \text{QTY} * \text{RLAFANS} + 0.49 + \text{FLAPUMP}$

THIS FORMULA WILL CALCULATE THE ACTUAL MOP BUT A TABLE IS REFERENCED TO PROVIDE THE APPROPRIATE MOP.

ACTUAL COLUMN A	MINIMUM COLUMN B*	MAXIMUM COLUMN C
0	15	0
15	20	15
20	25	20
25	30	25
30	35	30
35	40	35
40	45	40
45	50	45
50	60	50
60	70	60
70	80	70
80	90	80
90	100	90
100	110	100
110	125	110
125	150	125
150	175	150
175	200	175
200	225	200
225	250	225
250	300	250
300	350	300
350	400	350

USING AN APPROXIMATE MATCH, LOOK UP THE VALUE OF THE CALCULATED ACTUAL MOP IN COLUMN A. FIND THE LARGEST VALUE I.E. LESS THAN OR EQUAL TO THE VALUE IN COLUMN A. ONCE FOUND, THE VALUE IN COLUMN C WHICH SHARES THE SAME ROW IS THE VALUED USED IN THE SYSTEM. E.G. E.G. USING THE SAME EXAMPLE THAT WAS USED TO CALCULATE THE MCA, CALCULATE THE MOP:

ANS. ACTUAL = $2.25 * 20.4 + 20.4 + 0 + 2 * 2.6 + 5.29 = 45.9 + 30.89 = 76.79$ COMPARING AGAINST VALUES IN COLUMN A: $70 < 76.79 < 80$, THEREFORE THE USED MOP FOUND IN COLUMN C IS 70.

(*NOTE: COLUMN B IS USED IF ONE WERE CALCULATING THE MINIMUM DUAL ELEM FUSE WHICH IS NOT RELEVANT TO THIS EXERCISE.)

Power Wiring - Single Circuit

LEGEND

- \triangle = CTBI
- \circ = TBI
- - - = FIELD WIRING
- - - = OPTIONAL WIRING

ELEMENTARY DIAGRAM CONTROL CIRCUIT

035-20964-101
REV. B

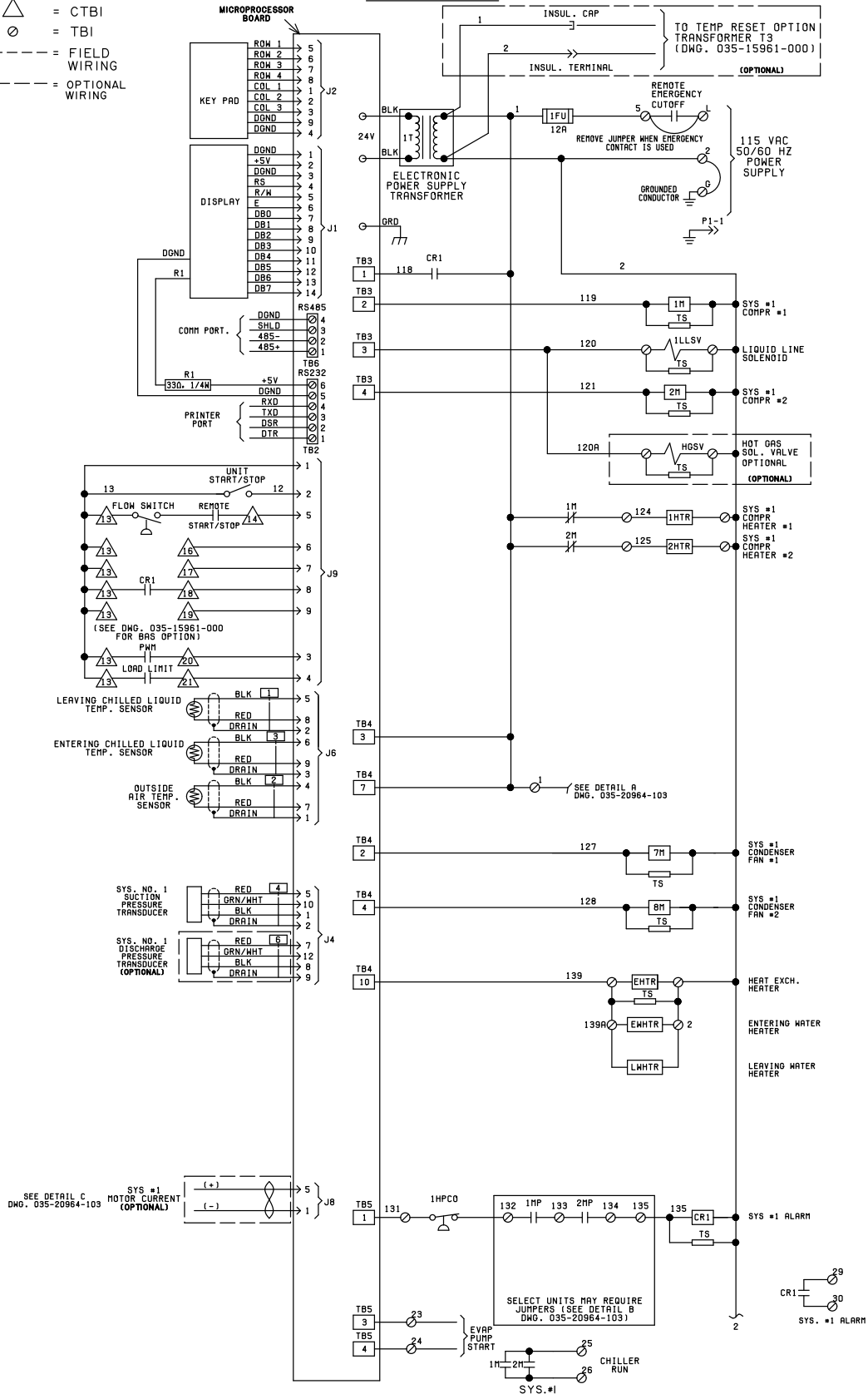

Power Wiring - Single Circuit - continued

ELEMENTARY DIAGRAM

035-20964-102
REV. A

POWER CIRCUIT

SYSTEM #1
FUSED DISCONNECT SW. OR
CIRCUIT BREAKER (BY OTHERS)

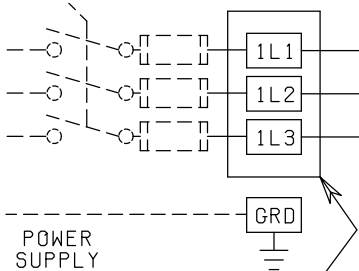

POWER TERMINAL BLOCK
(STANDARD)

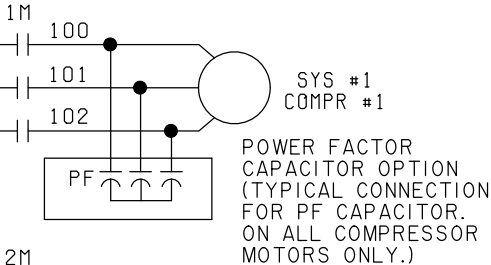

POWER FACTOR
CAPACITOR OPTION
(TYPICAL CONNECTION
FOR PF CAPACITOR.
ON ALL COMPRESSOR
MOTORS ONLY.)

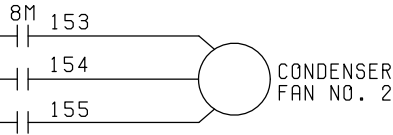
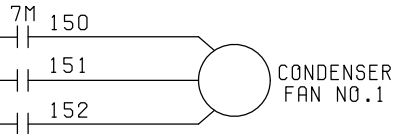
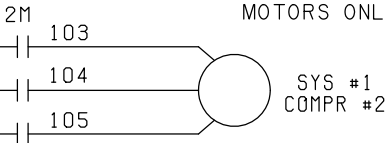

TRANSFORMER KIT
(OPTIONAL)
INCLUDES PRIMARY FUSES

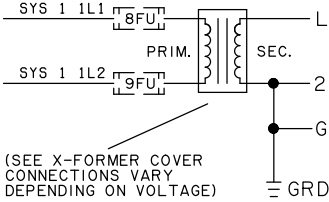

(SEE X-FORMER COVER
CONNECTIONS VARY
DEPENDING ON VOLTAGE)

CB/NF DISC. SW.
(OPTIONAL)

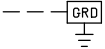

GFI OUTLET
(OPTIONAL)

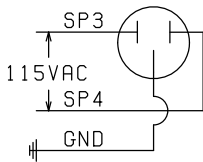

(SUPPLIED BY SEPERATE 120V FEED)

ELEMENTARY DIAGRAM

035-21031-102
REV. A

SYSTEM #1
FUSED DISCONNECT SW. OR
CIRCUIT BREAKER (BY OTHERS)

POWER CIRCUIT

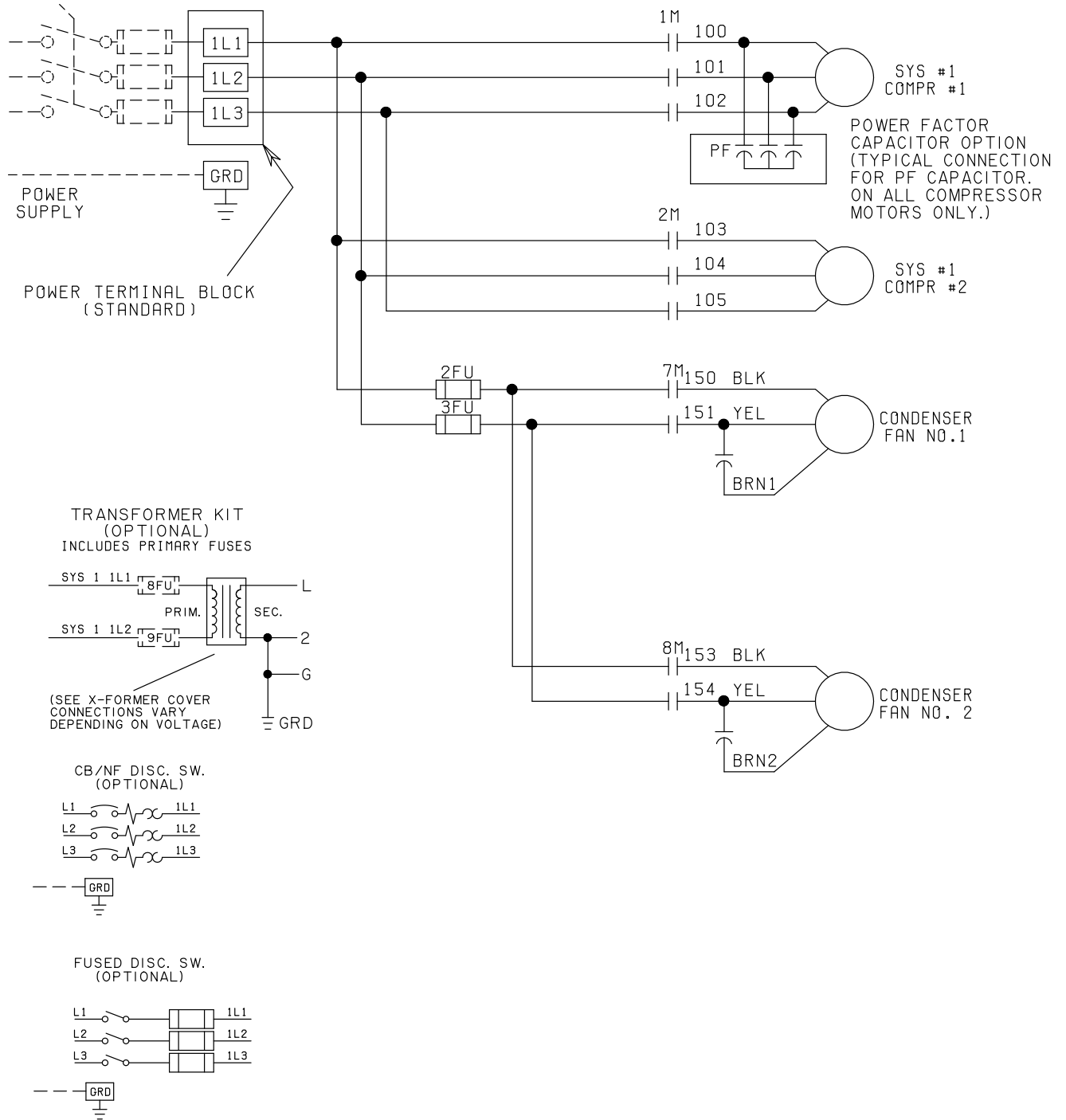

Power Wiring - Single Circuit - continued

035-21031-104
REV. A

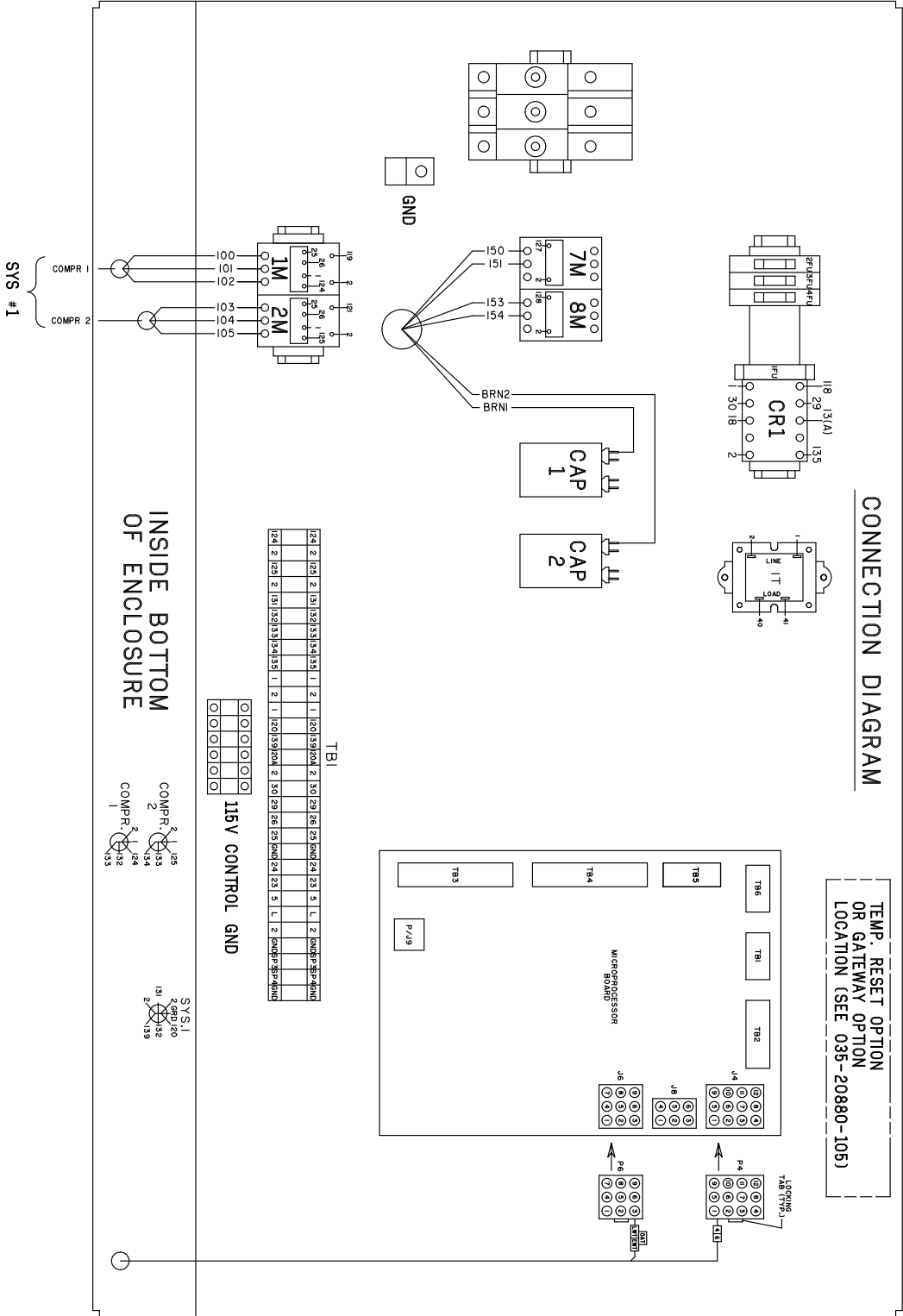

CTB1	
A+	
A	
D	
C	
21	
18	
20	
19	
13	
15	
13	
17	
15	
14	
13	

INSIDE BOTTOM
OF ENCLOSURE

115V CONTROL GND

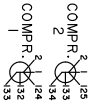

SYS #1

COMP R-1

COMP R-2

Power Wiring - Dual Circuit

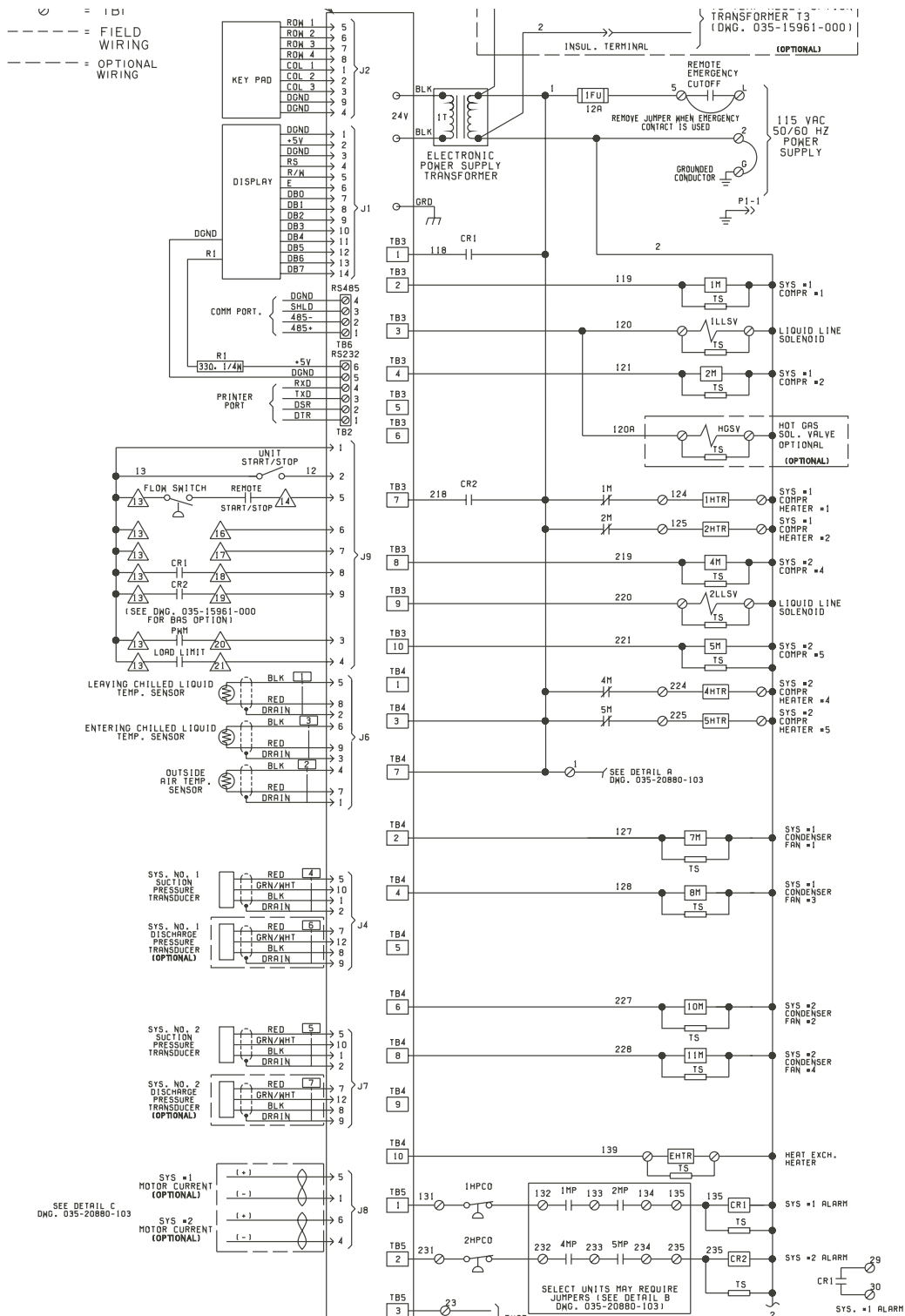

Power Wiring - Dual Circuit - continued

ELEMENTARY DIAGRAM

035-20880-102
REV. A

POWER CIRCUIT

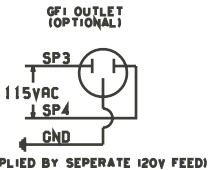
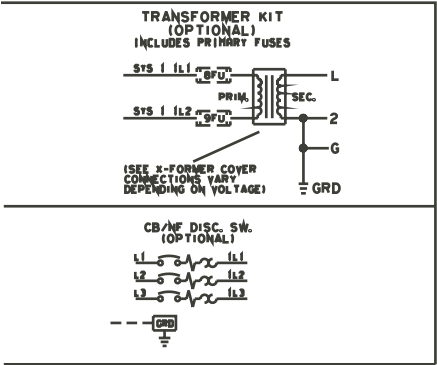
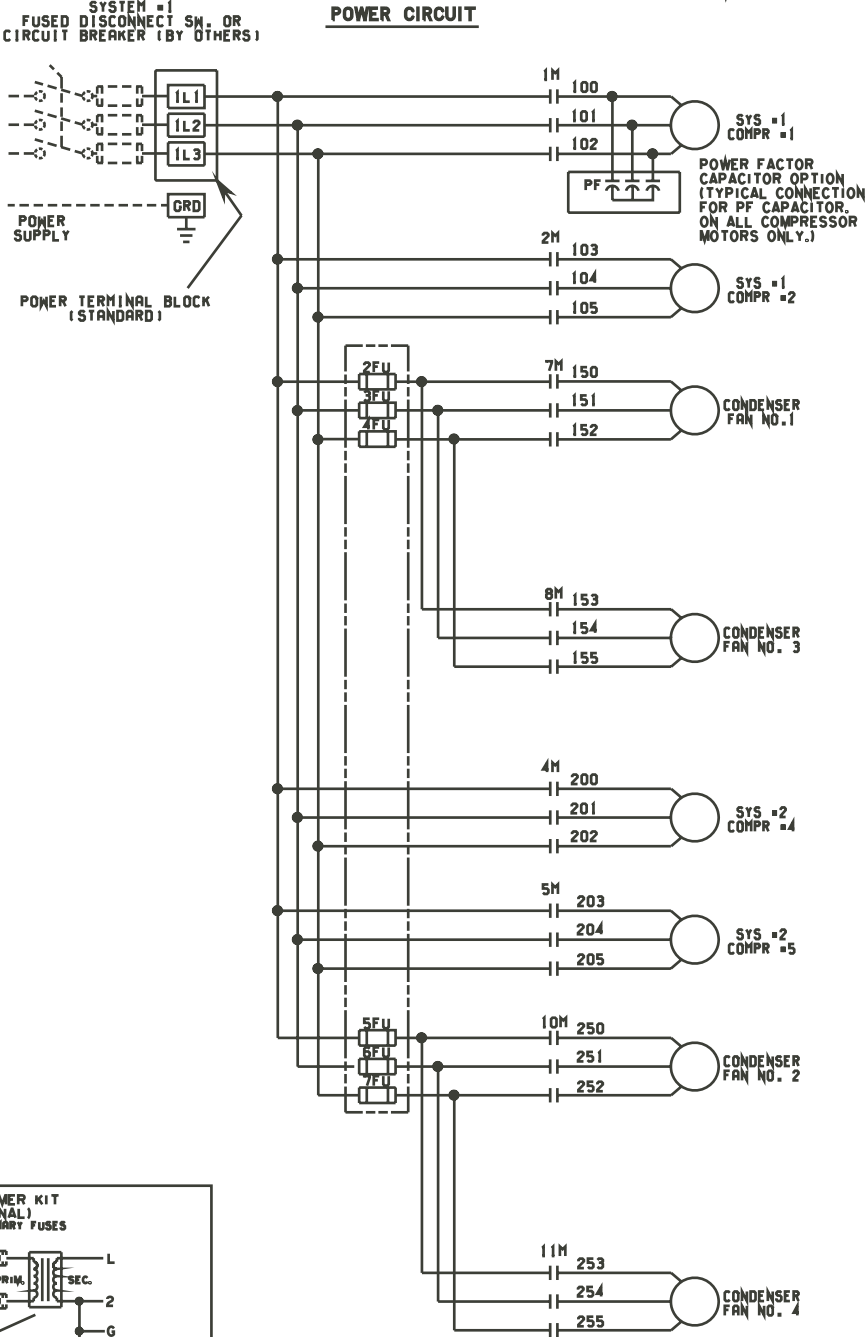

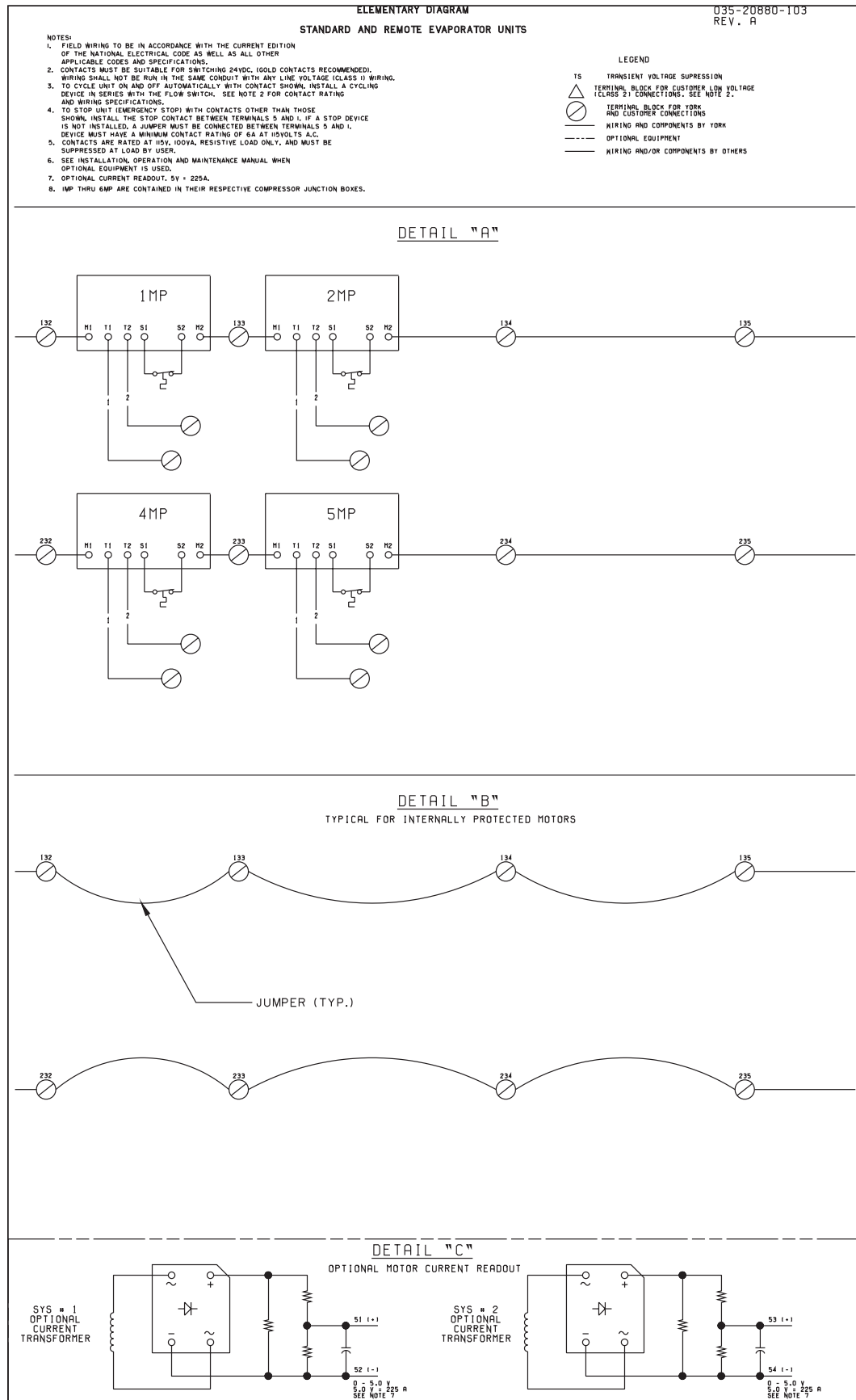

Power Wiring - Dual Circuit - continued

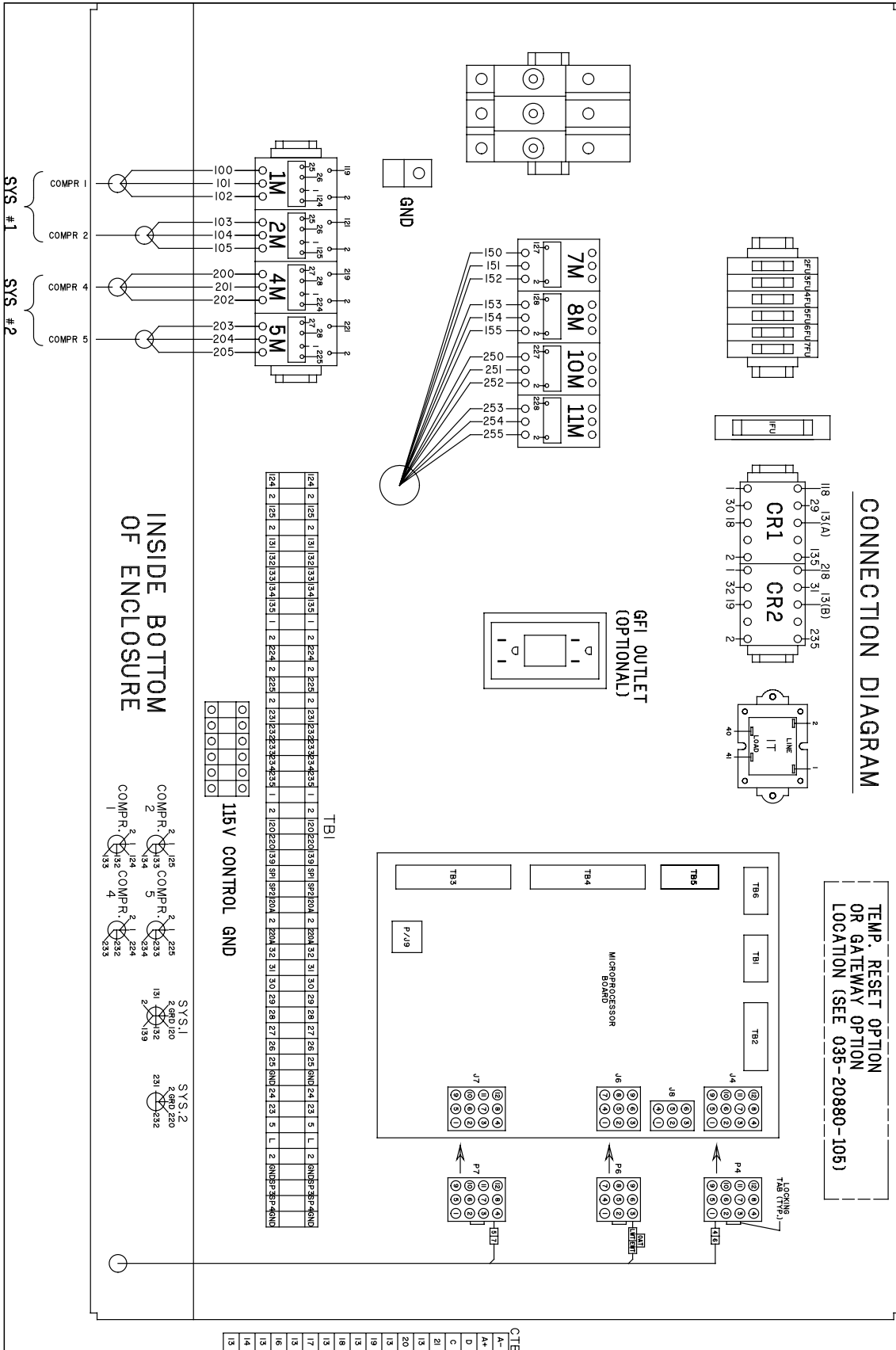

Control Wiring

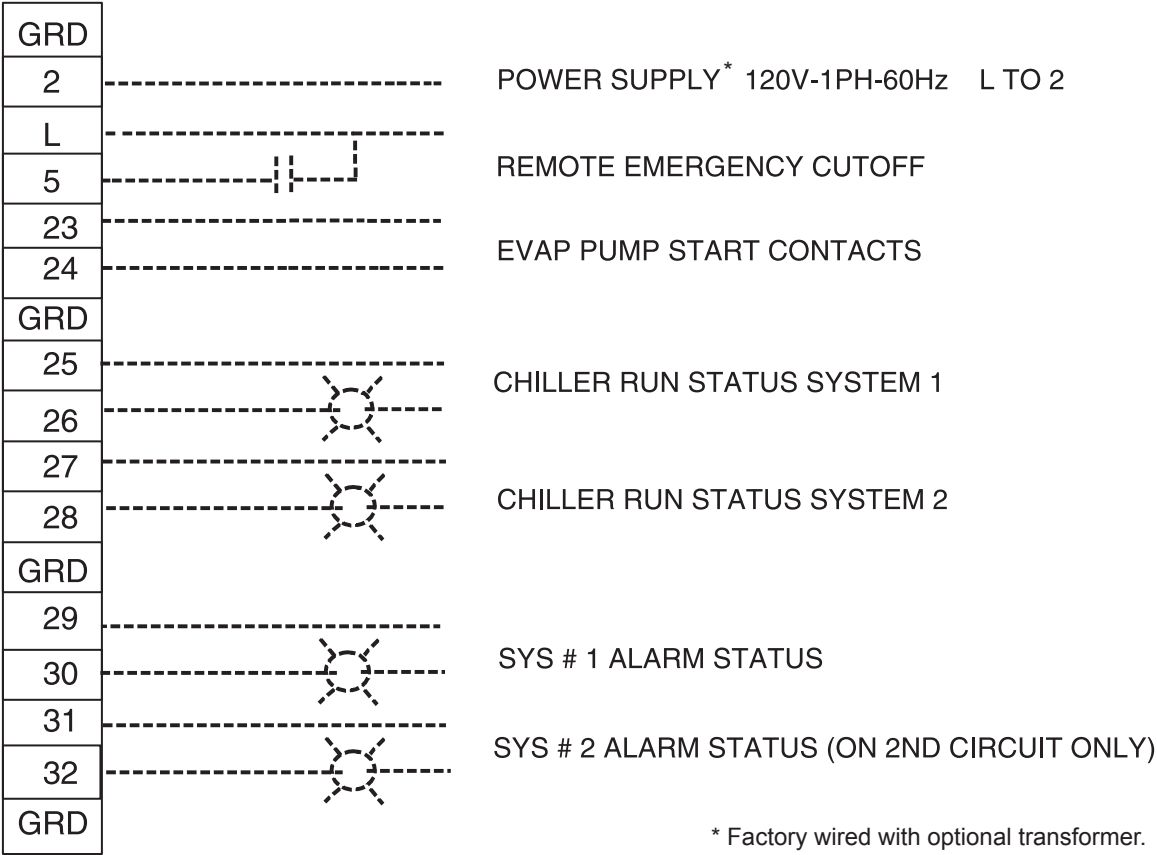
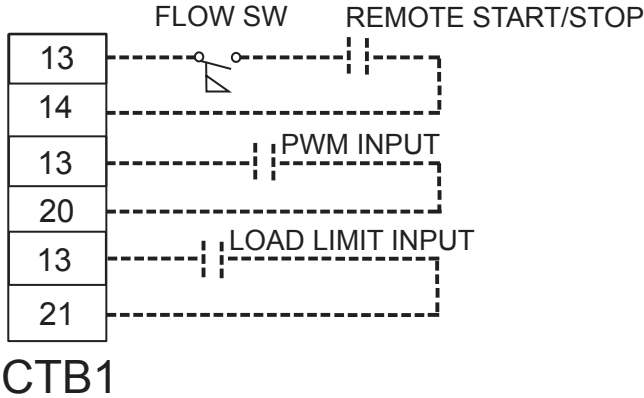

CTB2

FIG. 1 – STANDARD POWER SUPPLY WIRING – (YCAL 0014 - 0080)

Application Data

UNIT LOCATION

The YCAL chillers are designed for outdoor installation. When selecting a site for installation, be guided by the following conditions:

1. For outdoor locations of the unit, select a place having an adequate supply of fresh air for the condenser.
2. Avoid locations beneath windows or between structures where normal operating sounds may be objectionable.
3. Installation sites may be either on a roof, or at ground level. (See FOUNDATION.)
4. The condenser fans are the propeller-type, and are not recommended for use with duct work in the condenser air stream.
5. When it is desirable to surround the unit(s), it is recommended that the screening be able to pass the required chiller CFM without exceeding 0.1" of water external static pressure.
6. Protection against corrosive environments is available by supplying the units with either copper fin, cured epoxy-dipped, or epoxy-coated fins on the condenser coils. The epoxy-dipped or epoxy-coated coils should be offered with any units being installed at the seashore or where salt spray may hit the unit.

In installations where winter operation is intended and snow accumulations are expected, additional height must be provided to ensure normal condenser air flow.

Recommended clearances for units are given in DIMENSIONS. When the available space is less, the unit(s) must be equipped with the discharge pressure transducer option to permit high pressure unloading in the event that air recirculation were to occur.

FOUNDATION

The unit should be mounted on a flat and level foundation, ground or roof, capable of supporting the entire operating weight of the equipment. Operating weights are given in the PHYSICAL DATA tables.

ROOF LOCATIONS – Choose a spot with adequate structural strength to safely support the entire weight of the unit and service personnel. Care must be taken not to damage the roof during installation. If the roof is “bonded”, consult the building contractor or architect for special installation requirements. Roof installations should incorporate the use of spring-type isolators to minimize the transmission

of vibration into the building structure.

GROUND LEVEL INSTALLATIONS – It is important that the units be installed on a substantial base that will not settle, causing strain on the liquid lines and resulting in possible leaks. A one-piece concrete slab with footers extending below the frost line is highly recommended. Additionally, the slab should not be tied to the main building foundation, as noises will telegraph.

Mounting holes (11/16" diameter) are provided in the steel channel for bolting the unit to its foundation. See DIMENSIONS.

For ground level installations, precautions should be taken to protect the unit from tampering by or injury to unauthorized persons. Screws on access panels will prevent casual tampering; however, further safety precautions, such as unit enclosure options, a fenced-in enclosure, or locking devices on the panels may be advisable. Check local authorities for safety regulations.

CHILLED LIQUID PIPING

The chilled liquid piping system should be laid out so that the circulating pump discharges into the cooler. The inlet and outlet cooler liquid connections are given in DIMENSIONS.

Hand stop valves are recommended for use in all lines to facilitate servicing. Drain connections should be provided at all low points to permit complete drainage of the cooler and system piping.

The cooler must be protected by a strainer, preferably of 40 mesh, fitted as close as possible to the liquid inlet connection, and provided with a means of local isolation.

The cooler must not be exposed to flushing velocities or debris released during flushing. It is recommended that a suitably sized bypass and valve arrangement is installed to allow flushing of the piping system. The bypass can be used during maintenance to isolate the heat exchanger without disrupting flow to other units.

Pressure gauge connections are recommended for installation in the inlet and outlet water lines. Gauges are not furnished with the unit and are to be furnished by other suppliers.

The chilled liquid lines that are exposed to outdoor ambients should be wrapped with a supplemental heater cable and covered with insulation. As an alternative, ethylene glycol should be added to protect against freezeup during low ambient periods.

A flow switch is available as an accessory on all units. The flow switch (or its equivalent) must be installed in the leaving water piping of the cooler and must not be

Typical Piping for Brazed-Plate Coolers

Notes:

1. Placement on a level surface free of obstructions (including snow, for winter operation) or air recirculation ensures rated performance, reliable operation and ease of maintenance.
2. Piping and wiring shown is for reference use only

and is not in accordance with any national or local standards.

3. All wiring and piping must comply with applicable local and national codes.
4. All wiring and piping must follow standard piping techniques as discussed in the ASHRAE handbook.
5. A strainer with a mesh size between .5 and 1.5 mm is recommended upstream of the heat exchanger to prevent clogging.

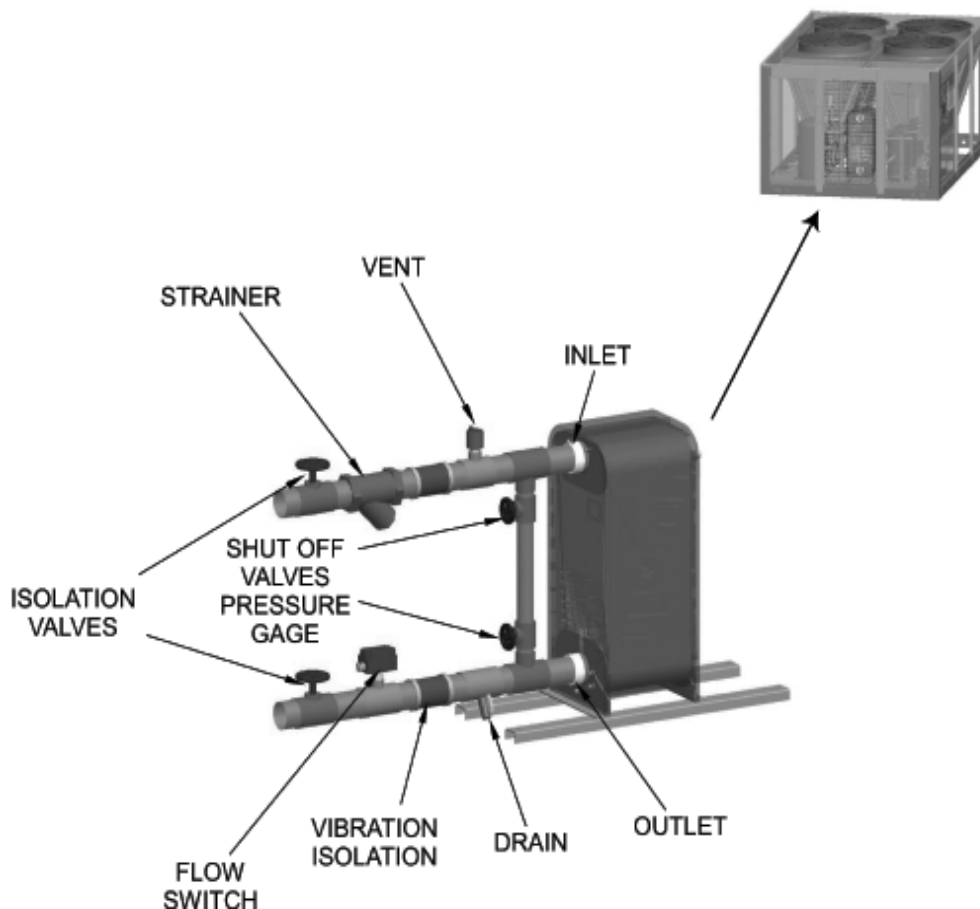

Guide Specifications

PART 1 – GENERAL

1.01 SCOPE

- A. The requirements of the General Conditions, Supplementary Conditions, Division 1, and Drawings apply to all Work herein.
- B. Provide Microprocessor controlled, multiple-scroll compressor, air-cooled, liquid chillers of the scheduled capacities as shown and indicated on the Drawings, including but not limited to:
 1. Chiller package
 2. Electrical power and control connections
 3. Chilled water connections
 4. Change of refrigerant oil (for factory mounted evaporator) or (evaporator shipped separately for field installation and piping by contractor)

1.02 QUALITY ASSURANCE

- A. Products shall be Designed, Tested, Rated and Certified in accordance with, and installed in compliance with applicable sections of the following Standards and Codes:
 1. ANSI/ASHRAE Standard 15 – Safety Code for Mechanical Refrigeration
 2. ASHRAE 90.1– Energy Efficiency compliance.
 3. ANSI/NFPA Standard 70 – National Electrical Code (N.E.C.).
 4. ASME Boiler & Pressure Vessel Code, Section VIII, Division 1.
 5. ARI Standard 550/590 – Positive Displacement Compressors and Air Cooled Rotary Screw Water-Chilling Packages.
 6. Conform to Intertek Testing Services, formerly ETL, for construction of chillers and provide ETL/cETL Listing label.
 7. Manufactured in facility registered to ISO9002.
 8. OSHA - Occupational Safety and Health Act
- B. Factory Test: Chiller shall be pressure-tested, evacuated and fully charged with refrigerant and oil, and shall be factory operational run tested with water flowing through the vessel.

- C. Chiller manufacturer shall have a factory trained and supported service organization that is within a 50 mile radius of the site.
- D. Manufacturer shall Warrant all equipment and material of its manufacture against defects in workmanship and material for a period of one year from date of initial start-up or eighteen (18) months from date of shipment, whichever occurs first.

1.03 DELIVERY AND HANDLING

- A. Unit shall be delivered to job site fully assembled, and charged with refrigerant and oil by the Manufacturer. (Contractor is responsible for providing and installing the refrigerant charge including the charge required for the field installed interconnecting piping. Chiller components shall ship with a dry nitrogen holding charge – Remote Evaporator option).
- B. Unit shall be stored and handled per Manufacturer's instructions.

PART 2 - PRODUCTS

2.01 CHILLER MATERIALS AND COMPONENTS

- A. **General:** Install and commission, as shown on the schedules and plans, factory assembled, charged, and tested air cooled scroll compressor chiller(s) as specified herein. Chiller shall be designed, selected, and constructed using a refrigerant with Flammability rating of "1", as defined by ANSI/ASHRAE STANDARD - 34 Number Designation and Safety Classification of Refrigerants. Chiller shall include, but is not limited to a complete system with a single refrigerant circuit 35 tons (123kW) and below, and not less than two refrigerant circuits above 35 tons (123kW), scroll compressors, direct expansion type evaporator, air-cooled condenser, refrigerant, lubrication system, interconnecting wiring, safety and operating controls including capacity controller, control center, motor starting components, and special features as specified herein or required for safe, automatic operation.
- B. **Cabinet:** External structural members shall be constructed of heavy gauge, galvanized steel coated with baked on powder paint which, when subject to ASTM B117, 1000 hour, 5% salt spray test, yields minimum ASTM 1654 rating of "6". Add Wire Panels of heavy gauge, welded wire-mesh, coated to resist corrosion, to protect condenser coils from incidental damage and restrict unauthorized access to internal components. Factory installed.

2.02 COMPRESSORS

Compressors: Shall be hermetic, scroll-type, including:

1. Compliant design with axial and radial sealing.
2. Refrigerant flow through the compressor with 100% suction cooled motor.
3. Large suction side free volume and oil sump to provide liquid handling capability.
4. Compressor crankcase heaters to provide extra liquid migration protection.
5. Annular discharge check valve and reverse vent assembly to provide low pressure drop, silent shutdown and reverse rotation protection.
6. Initial Oil charge.
7. Oil Level sightglass.
8. Vibration isolator mounts for compressors.
9. Brazed-type connections for fully hermetic refrigerant circuits.

2.03 REFRIGERANT CIRCUIT COMPONENTS

Each refrigerant circuit shall include liquid line shutoff valve with charging port, low side pressure relief device, filter-drier, solenoid valve, sight glass with moisture indicator, expansion valves, and flexible, closed-cell foam insulated suction line. Unit also includes service isolation valves as standard.

2.04 HEAT EXCHANGERS

A. Evaporator:

1. Evaporator shall be brazed-plate stainless steel construction, single or dual circuit heat exchangers capable of refrigerant working pressure of 650 psig (3103 kPa) and liquid side pressure of 150 psig (1034 kPa) (Option for 300 psig [2068 kPa] available.)
2. Evaporator shall be covered in 3/4" (19mm) flexible, closed cell insulation, thermal conductivity of 0.26k (BTU/HR-FT²-°F)/in.) maximum.
3. Cooler shall have thermostatically controlled heaters to protect to -20°F (29°C) ambient in off-cycle.
4. Brazed plate heat exchangers shall be UL listed.

5. Installing contractor must include accommodations in the chilled water piping to allow proper drainage and venting of the heat exchanger. A strainer with a mesh size between 0.5 and 1.5mm (40 mesh) is recommended upstream of the heat exchanger to prevent clogging.

B. Air Cooled Condenser:

1. **Coils:** Internally enhanced, seamless copper tubes, mechanically expanded into aluminum alloy fins with full height collars. Subcooling coil an integral part of condenser. Design working pressure shall be 650 PSIG (45 barg).
2. **Low Noise Fans:** Shall be dynamically and statically balanced, direct drive, propeller type fan, providing vertical air discharge and low sound. Each fan in its own compartment to prevent crossflow during fan cycling. Guards of heavy gauge, PVC (polyvinylchloride) coated or galvanized steel.
3. **Fan Motors:** High efficiency, direct drive, 6 pole, 3 phase, insulation class "F", current protected, Totally Enclosed Air-Over (TEAO), rigid mounted, with double sealed, permanently lubricated, ball bearings.

2.05 CONTROLS

- A. **General:** Automatic start, stop, operating, and protection sequences across the range of scheduled conditions and transients.
- B. **Microprocessor Enclosure:** Rain and dust tight NEMA 3R/12 powder painted steel cabinet with a gasket sealed protective cover.

C. Microprocessor Control Center:

1. Automatic control of compressor start/stop, anti-coincidence and anti-recycle timers, automatic pump-down on shutdown, condenser fans, evaporator pump, evaporator heater, unit alarm contacts, and chiller operation from 0°F to 125°F (-18°C to 52°C) ambient. Automatic reset to normal chiller operation after power failure.
2. Remote water temperature reset via a Pulse Width Modulated (PWM) input signal or up to two steps of demand (load) limiting.
3. Software stored in non-volatile memory, with programmed setpoints retained in lithium battery backed real time clock (RTC) memory for minimum 5 years.

Guide Specifications – continued

4. Forty character liquid crystal display, descriptions in English (or Spanish, French, Italian, or German), numeric data in English (or Metric) units. Sealed keypad with sections for Setpoints, Display/Print, Entry, Unit Options & clock, and On/Off Switch.
5. **Programmable Setpoints (within Manufacturer limits):** display language; chilled liquid temperature setpoint and range, remote reset temperature range, set daily schedule/holiday for start/stop, manual override for servicing, low and high AMBIENT °Cutouts, number of compressors, low liquid temperature cutout, low suction pressure cutout, high discharge pressure cutout, anti-recycle timer (compressor start cycle time), and anti-coincident timer (delay compressor starts).
6. **Display Data:** Return and leaving liquid temperatures, low leaving liquid temperature cutout setting, low ambient temperature cutout setting, outdoor air temperature, English or metric data, suction pressure cutout setting, each system suction pressure, discharge pressure (standard on YCAL0019-0066 models), liquid temperature reset via a Johnson Controls ISN DDCor Building Automation System (by others) via PWM input as standard or a 4-20milliamp or 0-10 VDC input or contact closure with optional BAS interface, anti-recycle timer status for each compressor, anti-coincident system start timer condition, compressor run status, no cooling load condition, day, date and time, daily start/stop times, holiday status, automatic or manual system lead/lag control, lead system definition, compressor starts/operating hours (each), status of hot gas valves, evaporator heater and fan operation, run permissive status, number of compressors running, liquid solenoid valve status, load & unload timer status, water pump status.
7. **System Safeties:** Shall cause individual compressor systems to perform auto shut down; manual reset required after the third trip in 90 minutes. Includes: high discharge pressure, low suction pressure, high pressure switch, and motor protector. Compressor motor protector shall protect against damage due to high input current or thermal overload of windings.
8. **Unit Safeties:** Shall be automatic reset and cause compressors to shut down if low ambient, low leaving chilled liquid temperature, under voltage, and flow switch operation. Contractor shall provide flow switch and wiring per chiller manufacturer requirements.
9. **Alarm Contacts:** Low ambient, low leaving chilled liquid temperature, low voltage, low battery, and (per compressor circuit): high discharge pressure, and low suction pressure.
 - D. Manufacturer shall provide any controls not listed above, necessary for automatic chiller operation. Mechanical Contractor shall provide field control wiring necessary to interface sensors to the chiller control system.

2.06 POWER CONNECTION AND DISTRIBUTION

A. Power Panels:

1. NEMA 3R, powder painted steel cabinets with a gasketed protective cover. Provide main power connection(s), control power connections, compressor and fan motor start contactors, current overloads, and factory wiring.
2. Power supply shall enter unit at a single location, be 3 phase of scheduled voltage, and connect to individual terminal blocks per compressor. Separate disconnecting means and/or external branch circuit protection (by Contractor) required per applicable local or national codes.

- B. Compressor, control and fan motor power wiring shall be fully contained within the unit enclosure, or shall be routed through liquid tight conduit.

2.07 ACCESSORIES AND OPTIONS

Some accessories and options supercede standard product features. Your Johnson Controls representative will be pleased to provide assistance.

- A. Microprocessor controlled, Factory installed Across-the-Line type compressor motor starters as standard.
- B. Outdoor Ambient Temperature Control
 1. **Low Ambient Control:** Permits unit operation to 0°F ambient.
 2. **High AMBIENT Control:** Permits unit operation above 115°F ambient.

C. Power Supply Connections:

1. **Single Point Power Supply:** Single point Terminal Block for field connection and interconnecting wiring to the compressors. Separate external protection must be supplied, by others, in the incoming power wiring, which must comply with the National Electric Code and/or local codes. Standard unit controls to 25°F ambient.
2. **Single Point or Disconnect:** Single or Dual point Non-Fused Disconnect(s) and lockable external handle (in compliance with Article 440-14 of N.E.C.) can be supplied to isolate the unit power voltage for servicing. Separate external fusing must be supplied, by others, in the incoming power wiring, which must comply with the National Electric Code and/or local codes.
3. **Single Point Circuit Breaker:** Single point Terminal Block with Circuit Breaker and lockable external handle (in compliance with Article 440-14 of N.E.C.) can be supplied to isolate power voltage for servicing. Incoming power wiring must comply with the National Electric Code and/or local codes. Single Point Circuit Breakers available on YCAL0019-0066 models.

D. Pressure Transducers and Readout Capability

1. **Discharge Pressure Transducers:** Permits unit to sense and display discharge pressure.

E. **Control Power Transformer:** Converts unit power voltage to 120-1-60 or 120-1-50 for 50Hz (500 VA capacity). Factory- mounting includes primary and secondary wiring between the transformer and the control panel.

F. **Motor Current Module:** Capable of monitoring compressor motor current. Provides extra protection against compressor reverse rotation, phase-loss and phase imbalance. Option consists of one module per electrical system. (Factory-mounted.)

G. **Power Factor Correction Capacitors:** Provided to correct unit compressor factors to a 0.90-0.95.

H. Condenser Coil Environmental Protection:

1. **Pre-Coated:** Epoxy coated aluminum fin stock to guard from corrosive agents and insulate

against galvanic potential. For mild seashore or industrial locations.

2. **Copper Fin:** Provide copper fins in lieu of aluminum.
3. **Post-Coated Dipped:** Dipped-cured coating on condenser coils for seashore and other corrosive applications (with the exception of strong alkalis, oxidizers, and wet bromine, chlorine and fluorine in concentrations greater than 100ppm).

I. Protective Chiller Panels (Factory or Field Mounted)

1. **Louvered Panels (condenser coils only):** Painted steel as per remainder of unit cabinet, over external condenser coil faces.
2. **Wire Panels (full unit):** Heavy gauge, welded wire-mesh, PVC-coated to resist corrosion, to protect condenser coils from incidental damage and restrict unauthorized access to internal components.
3. **Louvered Panels (full unit):** Painted steel as per remainder of unit cabinet, to protect condenser coils from incidental damage, visually screen internal components, and prevent unauthorized access to internal components.
4. **Louvered/Wire Panels:** Louvered steel panels on external condenser coil faces, painted as per remainder of unit cabinet. Heavy gauge, welded wire-mesh, coated to resist corrosion, around base of machine to restrict unauthorized access.

J. **Flow Switch (Field-mounted):** Vapor proof SPDT, NEMA 4X switch (___ 150 PSIG or ___ 300 PSIG), -20°F to 250°F.

K. **Differential Pressure Switch:** Alternative to an above mentioned flow switch. Pretempco model DPS300A-P40PF-82582-5 (300 psi max. working pressure) SPDT 5 amp 125/250VAC switch, Range 3-45 PSIG (0.2-3 barg), deadband 0.5 - 0.8 psi, with 1/4" NPTE Pressure Connections.

L. Evaporator options:

1. Provide 1½" cooler insulation in lieu of standard ¾".
2. Provide DX Cooler with 300 PSIG water-side design working pressure in lieu of standard 150 PSIG.

Guide Specifications – continued

3. Provide Raised Face Flanges for field installation on cooler nozzles and field piping:
 - a. 150 PSIG, welded Flanges.
 - b. 300 PSIG, welded Flanges.

- M. **Service Isolation valves:** Service suction and discharge (ball type) isolation valves are added to unit per system. This option also includes a system high pressure relief valve in compliance with ASHRAE 15. (Factory-mounted.)

- N. **Remote Cooler:** Manufacturer shall provide separately: chiller less evaporator, leaving and return water sensors, and liquid line components (solenoid valves, filter driers, sight glasses, and TXVs), as discrete elements of a complete factory system. Contractor shall be field erect system and provide interconnecting refrigerant piping and wiring in accordance with Manufacturer recommendations, and project plans and schedules. Where not otherwise specified, Contractor provided system piping shall be in accordance with applicable sections of ASHRAE Handbook.

- O. **Hot Gas By-Pass:** Permits continuous, stable operation at capacities below the minimum step of unloading to as low as 5% capacity (depending on both the unit & operating conditions) by introducing an artificial load on the cooler. Hot gas by-pass is installed on only one refrigerant circuit (System #1).

- P. **Microprocessor Membrane Keypad Graphics on in lieu of Standard English:**
 1. French language.
 2. German language.
 3. Spanish language.
 4. Italian language.

- Q. **Thermal Storage:** Leaving chilled liquid setpoint range for charge cycle from 25°F to 20°F minimum, with automatic reset of the leaving brine temperature up to 40°F above the setpoint. (Works with Option T)

- R. **Low Temperature Process Brine:** Leaving chilled liquid setpoint range 20°F to 30°F.

- S. Chicago Code Relief Valves to meet Chicago Code requirements.

- T. **Building Automation System (EMS) Reset Interface:** Chiller to accept 4 to 20mA, 0 to 10 VDC, or discrete contact closure input to reset the leaving chilled liquid temperature.

- U. **Sound Reduction (Factory-mounted):**
 1. Ultra quiet, low speed, reduced noise fans
 2. Compressor Acoustic Sound Blankets

- V. **Vibration Isolation (Field-Mounted):**
 1. Neoprene Pad Isolators.
 2. **1 Inch Deflection Spring Isolators:** Level adjustable, spring and cage type isolators for mounting under the unit base rails.
 3. **2 Inch Deflection Isolators:** Level adjustable, restrained mounts in rugged welded steel housing with vertical and horizontal limit stops. Housings shall be designed to withstand a minimum 1.0g accelerated force in all directions to 2 inches.

PART 3 - EXECUTION**3.01 Installation**

- A. **General:** Rig and Install in full accordance with Manufacturers requirements, Project drawings, and Contract documents.
- B. **Location:** Locate chiller as indicated on drawings, including cleaning and service maintenance clearance per Manufacturer instructions. Adjust and level chiller on support structure. If equipment provided exceeds height of scheduled chiller, installing contractor is responsible for additional costs associated with extending the height of parapet or screening walls/enclosures
- C. **Components:** Installing Contractor shall provide and install all auxiliary devices and accessories for fully operational chiller.
- D. **Electrical:** Coordinate electrical requirements and connections for all power feeds with Electrical Contractor (Division 16).
- E. **Controls:** Coordinate all control requirements and connections with Controls Contractor.
- F. **Finish:** Installing Contractor shall paint damaged and abraded factory finish with touch-up paint matching factory finish.

Printed on recycled paper

Form 150.67-EG1 (713) Supersedes: 150.67-EG1 (1012)

© 2013 Johnson Controls, Inc. P.O. Box 423, Milwaukee, WI 53201 Printed in USA

www.johnsoncontrols.com

