



Product Catalog

Air-Cooled Scroll Chillers
Model CGAM - Made in USA
20-130 Nominal Tons (50 Hz and 60 Hz)





Introduction

Design and manufacturing excellence makes Trane a leader in the air-cooled chiller market place. This tradition of using excellence to meet market demands is illustrated with the new Trane 20-130 ton nominal air-cooled chiller. The introduction of this next-generation chiller is an exciting step forward in energy-efficiency, sound, reliability, ease of serviceability, control precision, application versatility, and operational cost-effectiveness. The new chiller is designed to deliver proven Trane performance based on the redesign of a European model that has been a market leader, plus all the benefits of new heat transfer and fan designs, as well as, low-speed, direct-drive scroll compressors.

Important Design Advances and New Features

- Higher full-load and part-load energy efficiency that exceeds ASHRAE 90.1 and reduces operating costs.
- Significantly lower noise levels than other scroll compressor chillers.
- HFC-410A optimized design.
- Flow switch and water strainer are factory installed in the optimum locations for seamless operation and reduced chiller installation and maintenance time.
- Trane CH530™ with Adaptive Controls™ have improved fan algorithms for more reliable operation at extreme conditions.
- Single chiller time of day scheduling communication for easier control of small jobs.
- Easily integrated with existing BAS via BACnet™ or LonTalk™ communication interface.
- All major service components are close to the unit edge for safe and easy maintenance.
- The chiller is designed for easy serviceability with input from our extended experience in design, testing and field operation.



Table of Contents

Features and Benefits	4
Application Considerations	6
Model Number Descriptions	13
General Data	15
Performance Data	19
Controls	27
Electrical	31
Electrical Connections	36
Dimensions	40
Weights	50
Mechanical Specifications	51
Options	53



Features and Benefits

Reliability

- Years of laboratory testing, including running the chiller at extreme operating conditions, have resulted in optimized compressor and chiller systems reliability by confirming a robust design and verifying quality each step of the way.
- Direct-drive, low-speed scroll compressors with fewer moving parts provide maximum efficiency, high reliability, and low maintenance requirements. Suction gas-cooled motor stays at a uniformly low temperature for long motor life.
- The third generation microprocessor control system provides improved control capabilities with Adaptive Control™ to keep the unit operating even in adverse conditions. Advanced microelectronics protect both the compressor and the motor from typical electrical fault conditions like thermal overload and phase rotation.
- Standard factory-installed water strainer helps prevent system debris from affecting unit flow or heat transfer.
- Flow switch is factory-installed at the optimum location in the piping for reduced chiller installation cost and superior flow sensing, reducing the potential for nuisance trips.
- Exceptionally rigid condenser coil structure is manufactured with hairpin tubes which halves the number of braze joints significantly reducing the potential for leaks.
- Innovative condenser pressure integrated fan control algorithms and variable frequency drive on circuits' lead fans provides more reliable operation at extreme temperature conditions.

Life Cycle Cost-Effectiveness

- Industry leading full- and part-load efficiency
- Electronic expansion valve and high speed suction temperature sensor enables tight chilled water temperature control and low superheat, resulting in more efficient full-load and part-load operation than previously available.
- Partial heat recovery available to save energy on pre-heat or reheat applications.
- Pump package features standard variable speed drive on the pump motors eliminating the need for energy sapping chilled water system triple duty or balancing valves. Additionally, system commissioning and flexibility is greatly enhanced. Chilled water supply reliability is increased with the dual pump design, due to standard failure/recovery functionality.

Application Versatility

- Industrial/low temperature process cooling - Excellent operating temperature range and precise control capabilities enable tight control.
- Ice/thermal storage - Utilities and owners benefit from reduced cooling energy cost. The chiller's dual setpoint control and industry leading ice energy storage efficiency assures reliable operation and superior system efficiency Trane's partnership with CALMAC, brings a proven track record of successful installations across many markets; from churches and schools to sky scrapers and office buildings.
- Partial heat recovery - An optional factory-installed heat exchanger provides hot water for many needs; water preheat and reheat for enhanced system humidity control are just two. This option reduces operating costs associated with boilers/domestic hot water.

Simple, Economical Installation

- Standard sound levels are roughly 5-8 dBA less than the previous Trane air-cooled models, perfect for applying outdoor HVAC equipment in neighborhoods, such as K-12 schools.
- System integration available with LonTalk or BACnet through a single twisted-pair wire for a less expensive translation to an existing building automation system.
- Powder-coated paint provides superior durability, corrosion protection, and is less likely to be damaged while rigging/lifting/installing the chiller.
- Factory commissioned unit-mounted starter reduces overall job cost and improves system reliability by eliminating job site design, installation and labor coordination requirements.

Precision Control

- Easily integrated with existing BAS via BACnet or LonTalk communication interfaces.
- Microprocessor-based Trane CH530 controls monitor and maintain optimal operation of the chiller and its associated sensors, actuators, relays, and switches, all of which are factory-installed and tested prior to shipping.
- Adaptive Control maintains chiller operation under adverse conditions, when many other chillers might simply shut down. Operating conditions that are compensated for include high condensing pressure and low suction pressure.
- Advanced microprocessor controls enable variable primary flow applications providing chilled water temperature control accuracy of $\pm 2^{\circ}\text{F}$ (1.1°C) for flow changes up to 10 percent per minute, plus handling of flow changes up to 30 percent per minute with continuous operation.
- Easy-to-use operator interface displays all operating and safety messages, with complete diagnostics information, on a highly readable panel with a scrolling touch-screen display. Status and diagnostic messages are in plain language - no codes to interpret - and are available in 20 languages.

Improved Serviceability

- All major serviceable components are close to the edge. Service shutoff valves and water strainer are conveniently located to enable easy service.
- Water piping connections are factory piped to the edge of the unit to make installation safer and faster.
- Electronic expansion valve designed so controls can be removed and serviced without refrigerant handling.
- The optional pump package is designed to be serviced in place. The unit structure includes a rigging point for pump servicing, making inspection, cleaning and pump seal changes easier.
- High pressure transducer and temperature sensors mountings enable troubleshooting and replacement without removing refrigerant charge, greatly improving serviceability over the life of the unit.
- Dead front panel construction provides for enhanced service technician safety.



Application Considerations

Certain application constraints should be considered when sizing, selecting and installing Trane CGAM chillers. Unit and system reliability is often dependent upon proper and complete compliance with these considerations. Where the application varies from the guidelines presented, it should be reviewed with your local Trane account manager.

Note: *The terms water and solution are used interchangeably in the following paragraphs.*

Unit Sizing

Unit capacities are listed in the Performance Data section. Intentionally over-sizing a unit to assure adequate capacity is not recommended. Erratic system operation and excessive compressor cycling are often a direct result of an oversized chiller. In addition, an oversized unit is usually more expensive to purchase, install, and operate. If over sizing is desired consider using two smaller units.

Water Treatment

The use of untreated or improperly treated water in chillers may result in scaling, erosion, corrosion, and algae or slime buildup. This will adversely affect heat transfer between the water and system components. Proper water treatment must be determined locally and depends on the type of system and local water characteristics.

Neither salt nor brackish water is recommend for use in Trane air-cooled CGAM chillers. Use of either will lead to a shortened life. Trane encourages the employment of a qualified water treatment specialist, familiar with local water conditions, to assist in the establishment of a proper water treatment program.

Foreign matter in the chilled water system can also increase pressure drop and, consequently, reduce water flow. For this reason it is important to thoroughly flush all water piping to the unit before making the final piping connections to the unit.

The capacities give in the Performance Data section of this catalog are based on water with a fouling factor of 0.0001°F·ft²·h/Btu (in accordance with AHRI 550/590). For capacities at other fouling factors, see Performance Selection Software.

Effect of Altitude on Capacity

Chiller capacities given in the Performance Data section are based upon application at sea level. At elevations substantially above sea level, the decreased air density will decrease condenser capacity and, therefore, unit capacity and efficiency.

Ambient Limitations

Trane chillers are designed for year-round operation over a range of ambient temperatures. The air-cooled model CGAM chiller will operate in ambient temperatures of 32°F to 125°F (0°C to 52°C) for high ambient or 0°F to 125°F (-18°C to 52°C) for wide ambient. Operation down to 0°F requires the use of variable speed fans to modulate and maintain system differential pressure.

The minimum ambient temperatures are based on still conditions (winds not exceeding five mph). Greater wind velocities will result in a drop in head pressure, therefore increasing the minimum starting and operating ambient temperature. The Adaptive Control™ microprocessor will attempt to keep the chiller on-line when high or low ambient conditions exist, making every effort to avoid nuisance trip-outs and provide the maximum allowable tonnage.

Water Flow Limits

The minimum water flow rates are given in the General Data section of this catalog. Evaporator flow rates below the tabulated values will result in laminar flow causing freeze-up problems, scaling, stratification and poor control. The maximum evaporator water flow rate is also given. Flow rates exceeding those listed may result in very high pressure drop across the evaporator.

Flow Rates Out of Range

Many process cooling jobs require flow rates that cannot be met with the minimum and maximum published values within the CGAM evaporator. A simple piping change can alleviate this problem. For example: a plastic injection molding process requires 80 gpm (5.0 l/s) of 50°F (10°C) water and returns that water at 60°F (15.6°C). The selected chiller can operate at these temperatures, but has a minimum flow rate of 106 gpm (6.6 l/s). The system layout in Figure 1 can satisfy the process.

Figure 1. Flow Rate Out of Range Systems Solution

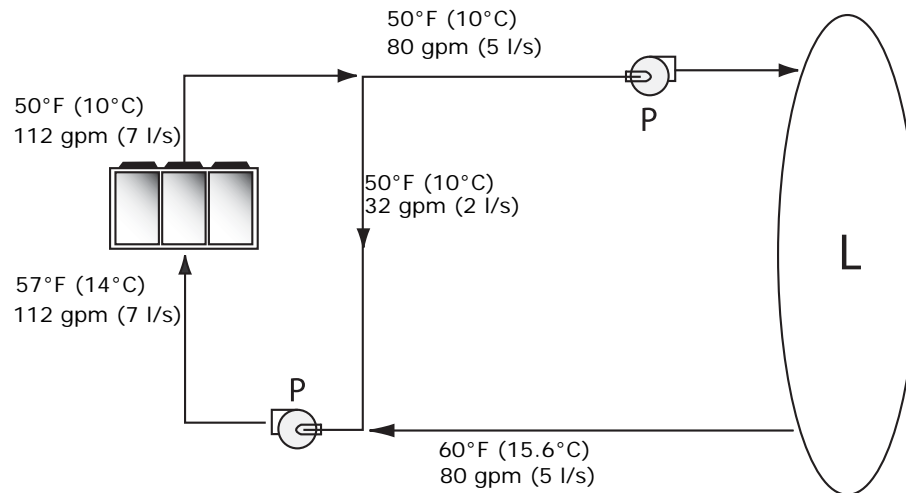

Flow Proving

Trane provides a factory-installed water flow switch monitored by CH530 which protects the chiller from operating in loss of flow conditions.

Variable Flow in the Evaporator

An attractive chilled water system option may be a Variable Primary Flow (VPF) system. VPF systems present building owners with several cost-saving benefits when compared with Primary/Secondary chilled water systems. The most obvious cost savings results from eliminating the constant volume chiller pump(s), which in turn eliminates the related expenses of the associated piping connections (material, labor), and electrical service and switch gear. In addition to the installed cost advantage building owners often cite pump related energy savings as the reasons that prompted them to select a VPF system.

The CGAM has the capability to handle variable evaporator flow without losing leaving water temperature control. The microprocessor and capacity control algorithms are designed to take a 10 percent change in water flow rate per minute while maintaining a $\pm 2^\circ\text{F}$ (1.1°C) leaving water temperature control accuracy. The chiller tolerates up to 30 percent per minute water flow variation as long as the flow is equal or above the minimum flow rate requirement.

With the help of a software analysis tool such as System Analyzer™, DOE-2 or TRACE™, you can determine whether the anticipated energy savings justify the use of variable primary flow in a particular application. Existing constant flow chilled water systems may be relatively easily converted to VPF and benefit greatly from the inherent efficiency advantages.

Water Temperature

Leaving Water Temperature Limits

Trane CGAM chillers have three distinct leaving water categories:

- standard, with a leaving solution range of 42 to 65°F (5.5 to 18°C)
- low temperature process cooling, with leaving solution range of 10 to 65°F (-12 to 18°C)
- ice-making, with leaving solution range of 20 to 65°F (-7 to 18°C)

Since leaving solution temperature below 42°F (5.5°C) results in suction temperature at or below the freezing point of water, a glycol solution is required for all low temperature and ice-making machines. Ice making control includes dual setpoint controls and safeties for ice making and standard cooling capabilities. Consult your local Trane account manager for applications or selections involving low temperature or ice making machines.

The maximum water temperature that can be circulated through the CGAM evaporator when the unit is not operating is 125°F (51.7°C). Evaporator damage may result above this temperature.

Leaving Water Temperature Out of Range

Similar to the flow rate limitations above, many process cooling jobs require temperature ranges that are outside the allowable minimum and maximum operating values for the chiller. Figure 2 below shows a simple example of a mixed water piping arrangement change that can permit reliable chiller operation while meeting such cooling conditions. For example, a laboratory load requires 238 gpm (5 l/s) of water entering the process at 86°F (30°C) and returning at 95°F (35°C). The chiller's maximum leaving chilled water temperature of 65°F (15.6°C) prevents direct supply to the load. In the example shown, both the chiller and process flow rates are equal, however, this is not necessary. For example, if the chiller had a higher flow rate, there would simply be more water bypassing and mixing with warm water returning to the chiller.

Figure 2. Temperature Out of Range System Solution

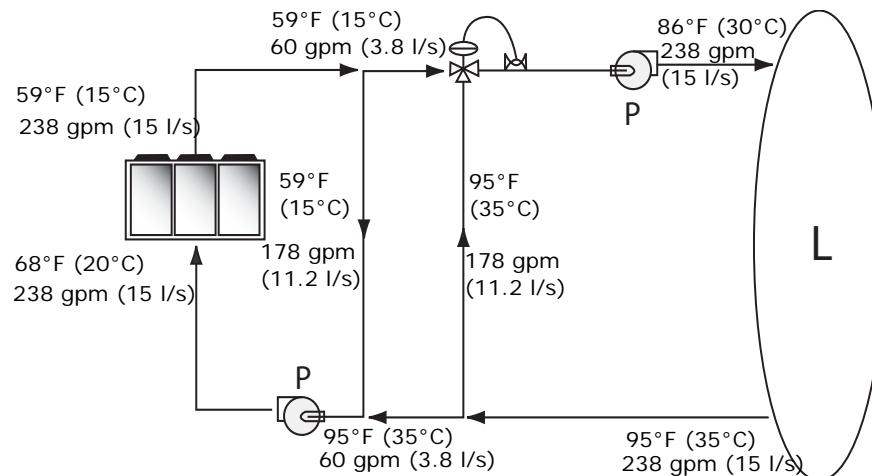

Supply Water Temperature Drop

The cataloged performance data for the Trane CGAM chiller is based on a chilled water temperature drop of 10°F (6°C) for I-P data and 9°F (5°C) for SI data. Full load chilled water temperature drops from 6 to 18°F (3.3 to 10°C) may be used as long as minimum and maximum water temperature and minimum and maximum flow rates are not violated. Temperature drops outside this range at full load conditions are beyond the optimum range for control and may adversely affect the microcomputer's ability to maintain an acceptable supply water temperature range. Furthermore, full load temperature drops of less than 6°F (3.3°C) may result in inadequate refrigerant superheat which is critical to long term efficient and reliable operation. Sufficient superheat is always a primary concern in any refrigerant system and is especially important in a packaged chiller where the evaporator is closely coupled to the compressor.

Typical Water Piping

All building water piping must be flushed prior to making final connections to the chiller. To reduce heat loss and prevent condensation, insulation should be applied. Expansion tanks are also usually required so that chilled water volume changes can be accommodated.

Avoidance of Short Water Loops

Adequate chilled water system water volume is an important system design parameter because it provides for stable chilled water temperature control and helps limit unacceptable short cycling of chiller compressors.

The chiller's temperature control sensor is located in the supply (outlet) water connection or pipe. This location allows the building to act as a buffer to slow the rate of change of the system water temperature. If there is not a sufficient volume of water in the system to provide an adequate buffer, temperature control can suffer, resulting in erratic system operation and excessive compressor cycling.

Typically, a two-minute water loop circulation time is sufficient to prevent short water loop issues. Therefore, as a guideline, ensure the volume of water in the chilled water loop equals or exceeds two times the evaporator flow rate. For systems with a rapidly changing load profile the amount of volume should be increased.

If the installed system volume does not meet the above recommendations, the following items should be given careful consideration to increase the volume of water in the system and, therefore, reduce the rate of change of the return water temperature.

- A volume buffer tank located in the return water piping.
- Larger system supply and return header piping (which also reduces system pressure drop and pump energy use).

Minimum water volume for a process application

If a chiller is attached to an on/off load such as a process load, it may be difficult for the controller to respond quickly enough to the very rapid change in return solution temperature if the system has only the minimum water volume recommended. Such systems may cause chiller low temperature safety trips or in the extreme case evaporator freezing. In this case, it may be necessary to add or increase the size of the mixing tank in the return line.

Multiple Unit Operation

Whenever two or more units are used on one chilled water loop, Trane recommends that their operation be coordinated with a higher level system controller for best system efficiency and reliability. The Trane Tracer system has advanced chilled plant control capabilities designed to provide such operation.

Application Considerations

Ice Storage Operation

An ice storage system uses the chiller to make ice at night when utilities generate electricity more efficiently and charge less for electricity with lower demand and energy charges. The stored ice reduces or even replaces mechanical cooling during the day when utility rates are at their highest. This reduced need for cooling results in significant utility cost savings and source energy savings.

Another advantage of an ice storage system is its ability to eliminate chiller over sizing. A “rightsized” chiller plant with ice storage operates more efficiently with smaller support equipment while lowering the connected load and reducing operating costs. Best of all this system still provides a capacity safety factor and redundancy by building it into the ice storage capacity for practically no cost compared to over sized systems.

The Trane air-cooled chiller is uniquely suited to low temperature applications like ice storage because of the ambient relief experienced at night. Chiller ice making efficiencies are typically similar to or even better than standard cooling daytime efficiencies as a result of night-time dry-bulb ambient relief.

Standard smart control strategies for ice storage systems are another advantage of the CGAM chiller. The dual mode control functionality are integrated right into the chiller. Trane Tracer building management systems can measure demand and receive pricing signals from the utility and decide when to use the stored cooling and when to use the chiller.

Partial Heat Recovery Operation

Partial heat recovery is designed to salvage a portion of the heat that is normally rejected to the atmosphere through the air-cooled condenser coil and put it to beneficial use. With the addition of a heat recovery cycle, heat removed from the building cooling load can be transferred to a preheat application. Keep in mind that the heat recovery cycle is only possible if a cooling load exists to act as a heat source.

To provide a heat recovery cycle, a supplemental heat exchanger is mounted in series to the air-cooled condenser. The supplemental heat exchanger is piped into a preheat circuit. During the heat recovery cycle, the unit operates just as it does in the cooling-only mode except that a portion of the cooling load heat is rejected to the water heating circuit rather than to the air through the air-cooled condenser. Water circulated through the heat recovery heat exchanger by the pumps absorbs cooling load heat from the compressed refrigerant gas discharged by the compressors. The heated water is then used to satisfy heating requirements.

Partial heat recovery can be used in applications where hot water is needed for use in kitchens, lavatories, etc. It is comparatively smaller in size and its heating capacity is not controlled. The partial heat recovery heat exchanger cannot operate alone without a load on the chiller.

The partial heat recovery heat exchanger can get up to 157°F (69.4°C) leaving temperature. For more information see the Performance Selection Program.

Unit Placement

Setting The Unit

A base or foundation is not required if the selected unit location is level and strong enough to support the unit’s operating weight (see “Weights” section of this catalog).

For a detailed discussion of base and foundation construction, refer to the sound engineering bulletin or the unit IOM. Manuals are available through the local Trane office.

HVAC equipment must be located to minimize sound and vibration transmission to the occupied spaces of the building structure it serves. If the equipment must be located in close proximity to a building, it should be placed next to an unoccupied space such as a storage room, mechanical room, etc. It is not recommended to locate the equipment near occupied, sound sensitive areas of the building or near windows. Locating the equipment away from structures will also prevent sound reflection, which can increase sound levels at property lines or other sensitive points.

Isolation and Sound Emission

Structurally transmitted sound can be reduced by elastomeric vibration eliminators. Elastomeric isolators are generally effective in reducing vibratory noise generated by compressors, and therefore, are recommended for sound sensitive installations. An acoustical engineer should always be consulted on critical applications.

Figure 3. Installation Example

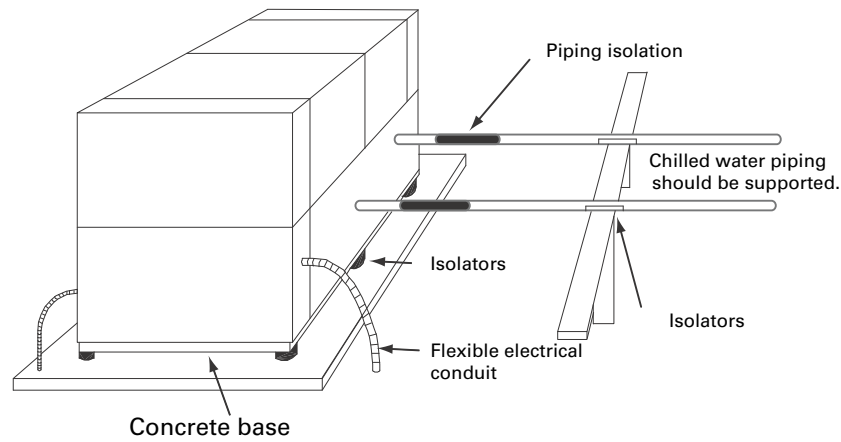

For maximum isolation effect, water lines and electrical conduit should also be isolated. Wall sleeves and rubber isolated piping hangers can be used to reduce the sound transmitted through water piping. To reduce the sound transmitted through electrical conduit, use flexible electrical conduit.

Local codes on sound emissions should always be considered. Since the environment in which a sound source is located affects sound pressure, unit placement must be carefully evaluated. Sound power levels for chillers are available on request.

Servicing

Adequate clearance for evaporator and compressor servicing should be provided. Recommended minimum space envelopes for servicing are located in the dimensional data section and can serve as a guideline for providing adequate clearance. The minimum space envelopes also allow for control panel door swing and routine maintenance requirements. Local code requirements may take precedence.

Application Considerations

Unit Location

General

Unobstructed flow of condenser air is essential to maintain chiller capacity and operating efficiency. When determining unit placement, careful consideration must be given to assure a sufficient flow of air across the condenser heat transfer surface. Two detrimental conditions are possible and must be avoided: warm air recirculation and coil starvation. Air recirculation occurs when discharge air from the condenser fans is recycled back to the condenser coil inlet. Coil starvation occurs when free airflow to the condenser is restricted.

Condenser coils and fan discharge must be kept free of snow or other obstructions to permit adequate airflow for satisfactory unit operation. Debris, trash, supplies, etc., should not be allowed to accumulate in the vicinity of the air-cooled chiller. Supply air movement may draw debris into the condenser coil, blocking spaces between coil fins and causing coil starvation.

Both warm air recirculation and coil starvation cause reductions in unit efficiency and capacity because of the higher head pressures associated with them. The air-cooled CGAM chiller offers an advantage over competitive equipment in these situations. Operation is minimally affected in many restricted air flow situations due to its advanced Adaptive Control™ microprocessor which has the ability to understand the operating environment of the chiller and adapt to it by first optimizing its performance and then staying on line through abnormal conditions. For example, high ambient temperatures combined with a restricted air flow situation will generally not cause the air-cooled model CGAM chiller to shut down. Other chillers would typically shut down on a high pressure nuisance cut-out in these conditions.

Cross winds, those perpendicular to the condenser, tend to aid efficient operation in warmer ambient conditions. However, they tend to be detrimental to operation in lower ambients due to the accompanying loss of adequate head pressure. Special consideration should be given to low ambient units. As a result, it is advisable to protect air-cooled chillers from continuous direct winds exceeding 10 mph (4.5 m/s) in low ambient conditions.

The recommended lateral clearances are depicted in the close spacing engineering bulletin available from your local office.

Provide Sufficient Unit-to-Unit Clearance

Units should be separated from each other by sufficient distance to prevent warm air recirculation or coil starvation. Doubling the recommended single unit air-cooled chiller clearances will generally prove to be adequate.

Walled Enclosure Installations

When the unit is placed in an enclosure or small depression, the top of the surrounding walls should be no higher than the top of the fans. The chiller should be completely open above the fan deck. There should be no roof or structure covering the top of the chiller. Ducting individual fans is not recommended.



Model Number Descriptions

Digit 1-4 – Chiller Model

CGAM = Air-Cooled Scroll Packaged Chiller

Digit 5-7 – Unit Nominal Tonnage

020 = 20 Tons
026 = 26 Tons
030 = 30 Tons
035 = 35 Tons
040 = 40 Tons
052 = 52 Tons
060 = 60 Tons
070 = 70 Tons
080 = 80 Tons
090 = 90 Tons
100 = 100 Tons
110 = 110 Tons
120 = 120 Tons
130 = 130 Tons

Digit 8 – Unit Voltage

A = 208 Volt 60 Hz 3 Phase
B = 230 Volt 60 Hz 3 Phase
D = 380 Volt 60 Hz 3 Phase
E = 400 Volt 50 Hz 3 Phase
F = 460 Volt 60 Hz 3 Phase
G = 575 Volt 60 Hz 3 Phase

Digit 9 – Manufacturing Plant

2 = Pueblo, USA

Digit 10-11 – Design Sequence

A-Z = Factory/ABU Assigned

Digit 12 – Unit Type

2 = High Efficiency/Performance

Digit 13 – Agency Listing

X = No Agency Listing
A = UL Listed to US and Canadian Safety Standard

Digit 14 – Pressure Vessel Code

X = No Pressure Vessel Code

Digit 15 – Unit Application

B = High Ambient (32 to 125°F/0 to 52°C)
D = Wide Ambient (0 to 125°F/-18 to 52°C)

Digit 16 – Refrigerant Isolation Valves

2 = Refrigerant Isolation Valves (Discharge Valve)

Digit 17 – Seismically Rated Unit

A = Not Seismically Rated Unit
B = IBC Seismically Rated Unit
C = OSHPD Seismically Rated Unit

Digit 18 – Freeze Protection (Factory-Installed Only)

1 = With Freeze Protection (External T-Stat Control)

Digit 19 – Insulation

A = Factory Insulation - All Cold Parts
B = Insulation for High Humidity/ Low Evap Temp

Digit 20 – Factory Charge

1 = Full Factory Refrigerant Charge (HFC-410A)
2 = Nitrogen Charge

Digit 21 – Evaporator Application

A = Standard Cooling (42 to 65°F/5.5 to 18°C)
B = Low Temperature Processing (lower than 42°F/5.5°C)
C = Ice-Making - hardwired interface (20 to 65°F/-7 to 18°C)

Digit 22 – Water Connection (Evap)

1 = Grooved Pipe Connection

Digit 23 – Condenser Fin Material

A = Lanced Aluminum Fins
C = Non-Lanced Copper Fins
D = Lanced Aluminum Fins w/ CompleteCoat™

Digit 24 – Condenser Heat Recovery

X = No Heat Recovery
1 = Partial Heat Recovery w/ Fan Control

Digit 25

X

Digit 26 – Starter Type

A = Across the Line Starter/ Direct on Line



Model Number Descriptions

Digit 27 – Incoming Power Line Connection

- 1 = Single Point Power Connection

Digit 28 – Power Line Connection Type

- A = Terminal Block Conn. For Incoming Lines
- C = Circuit Breaker
- D = Circuit Breaker with High Fault Rated Control Panel

Digit 29 – Enclosure Type

- 1 = Water Tight (Per UL 1995 Standard)

Digit 30 – Unit Operator Interface

- A = Dyna-View/English
- C = Dyna-View/Spanish-Mexico
- D = Dyna-View/French
- K = Dyna-View/Portuguese-Brazil
- M = Dyna-View/Thai
- N = Dyna-View/Simplified Chinese
- P = Dyna-View/Traditional Chinese

Digit 31 – Remote Interface (digital comm)

- X = No Remote Digital Communication
- 2 = LonTalk/Tracer Summit Interface
- 3 = Time of Day Scheduling
- 4 = BACNet Interface

Digit 32 – Ext. Chilled/Hot Water and Curr. Demand Limit Setpoint

- X = No Ext. Chilled Water Setpoint
- A = Ext Chilled Water and Demand Limit Setpoint - 4-20mA
- B = Ext Chilled Water and Demand Limit Setpoint - 2-10Vdc

Digit 33 – % Capacity

- X = Without % Capacity
- 1 = With % Capacity

Digit 34 – Programmable Relays

- X = No Programmable Relays
- A = Programmable Relays

Digit 35 – Pump Type

- X = No Pumps and no Contactors
- 8 = Dual High Head Pump

Digit 36 – Pump Flow Control

- X = No Pump Control
- B = Pump Flow Controlled by Variable Speed Drive

Digit 37

- X =

Digit 38 – Short Circuit Rating

- A = Default A Short Circuit Rating
- B = High A Short Circuit Rating

Digit 39 – Installation Accessories

- X = No Installation Accessories
- 1 = Elastomeric Isolators
- 3 = Seismically Rated Isolators

Digit 40 – Water Strainer

- A = With Water Strainer Factory-Installed

Digit 41 – Sound Attenuator Package

- 3 = Super Quiet
- 5 = Comprehensive Acoustic Package

Digit 42 – Appearance Options

- X = No Appearance Options
- A = Architectural Louvered Panels
- B = Half Louvers

Digit 43 – Exterior Finish

- 1 = Standard Paint

Digit 44 – Literature Language

- B = Spanish
- D = English
- E = French

Digit 45 – Phase Reversal Protection

- 1 = Phase Reversal Protection

Digit 46 – Shipping Package

- X = No Skid (Standard)
- A = Unit Containerization Package

Digit 47 – Performance Test Options

- X = No Performance Test
- 2 = 1 Point Test with Report
- 3 = Witness 1 Point Test with Report

Digit 48 – Flow Switch Setpoint

- C = Flow Switch Set Point 15
- F = Flow Switch Set Point 35
- H = Flow Switch Set Point 45
- L = Flow Switch Set Point 60

Digit 49

- X

Digit 50 – Specials

- X = None
- S = Special

Notes:

1. If a digit is not defined it may be held for future use.



General Data

Table 1. General Data - 60 Hz - IP

Size		20	26	30	35	40	52	60	70	80	90	100	110	120	130
Compressor															
Number	#	2	2	2	2	4	4	4	4	4	4	4	4	4	6
Tonnage/circuit ¹		10+10	13+13	15+15	15+20	10+10	13+13	15+15	15+20	20+20	20+25	25+25	25+30	30+30	20+20 +25
Evaporator															
Water storage	(gal)	1.4	2.2	2.2	3.2	2.4	4.1	5.0	7.5	7.0	9.0	10.3	11.5	11.5	12.3
Min. flow	(gpm)	30	38	42	50	57	74	84	100	115	129	145	157	170	184
Max. flow	(gpm)	69	89	100	117	136	176	201	238	275	307	346	375	407	440
Water connection	(in)	2	2.5	2.5	2.5	3	3	3	3	4	4	4	4	4	4
Condenser															
Quantity of coils	#	1	1	1	1	2	2	2	2	4	4	4	4	4	4
Coil length	(in)	91	91	127	127	91	91	127	127	121	121	144	144	144	180
Coil height	(in)	68	68	68	68	68	68	68	68	42	42	42	42	42	42
Number of rows	#	2	2	2	2	2	2	2	2	3	3	3	3	3	3
Fins per foot	(fpf)	192	192	192	192	192	192	192	192	192	192	192	192	192	192
Fan															
Quantity	#	2	2	3	3	4	4	6	6	6	6	8	8	8	10
Diameter	(in)	28.8	28.8	28.8	28.8	28.8	28.8	28.8	28.8	28.8	28.8	28.8	28.8	28.8	28.8
Airflow per fan	(cfm)	9413	9420	9168	9173	9413	9420	9168	9173	9470	9472	9094	9096	9098	9094
Power per motor	(kW)	1.2	1.2	1.2	1.2	1.2	1.2	1.2	1.2	1.2	1.2	1.2	1.2	1.2	1.2
Motor RPM	(rpm)	840	840	840	840	840	840	840	840	840	840	840	840	840	840
Tip speed	(ft/min)	6333	6333	6333	6333	6333	6333	6333	6333	6333	6333	6333	6333	6333	6333
General Unit															
Refrig circuits	#	1	1	1	1	2	2	2	2	2	2	2	2	2	2
Capacity steps	%	50-100	50-100	50-100	43-100	25-50- 75-100	25-50- 75-100	25-50- 75-100	21-43- 71-100	25-50- 75-100	22-44- 72-100	25-50- 75-100	23-45- 73-100	25-50- 75-100	15-31- 46-62- 81-100
Refrig charge/circuit ¹	(lbs)	32	34	48	48	32	32	50.5	48	74	78	81	91.5	86	112
Oil charge/circuit ¹	(gal)	1.7	1.7	3.5	3.5	1.7	1.7	3.5	3.5	3.5	3.5	3.5	3.7	3.8	5.8
Min ambient - wide	(°F)	0	0	0	0	0	0	0	0	0	0	0	0	0	0
Min ambient - high	(°F)							n/a				32	32	32	32
Pump Package															
Avail head pressure ²	(ft H2O)	78.2	77.7	71.1	67.6	67.1	58.6	76.7	63.5	82.0	78.1	69.0	61.9	71.3	62.2
Power	(HP)	5.0	5.0	5.0	5.0	5.0	5.0	7.6	7.6	10.2	10.2	10.2	10.2	15.2	15.2
Expansion tank volume	(gal)	5	5	5	5	5	5	5	5	6	6	6	6	6	6
Partial Heat Recovery															
Water storage/circuit ¹	(gal)	0.02	0.02	0.02	0.03	0.02	0.02	0.02	0.03	0.03	0.04	0.04	0.04	0.06	0.06
Max flow	(gpm)	39	39	39	39	78	78	78	78	127	127	127	127	127	127
Water connection	(in)	1.5	1.5	1.5	1.5	1.5	1.5	1.5	1.5	2.5	2.5	2.5	2.5	2.5	2.5

1. Data shown for circuit one only. The second circuits always matches.

2. Pump available head pressure is based on: 44/54°F evaporator with water, .0001 hr-ft²-°F/Btu, 95°F ambient and 0 ft elevation.



General Data

Table 2. General Data - 60 Hz - SI

Size		20	26	30	35	40	52	60	70	80	90	100	110	120	130	
Compressor																
Number	#	2	2	2	2	4	4	4	4	4	4	4	4	4	4	6
Tonnage/circuit ¹		10+10	13+13	15+15	15+20	10+10	13+13	15+15	15+20	20+20	20+25	25+25	25+30	30+30	20+20+25	
Evaporator																
Water storage	(l)	5.3	8.3	8.3	12.1	9.1	15.5	18.9	28.4	26.5	34.1	39.0	43.5	43.5	46.6	
Min. flow	(l/s)	1.8	2.3	2.6	3.1	3.6	4.6	5.3	6.3	7.2	8.1	9.1	9.9	10.7	11.6	
Max. flow	(l/s)	4.4	5.6	6.3	7.4	8.6	11.1	12.7	15.1	17.4	19.4	21.9	23.7	25.7	27.8	
Water connection	(mm)	50.8	63.5	63.5	63.5	76.2	76.2	76.2	76.2	101.6	101.6	101.6	101.6	101.6	101.6	
Condenser																
Qty of coils	#	1	1	1	1	2	2	2	2	4	4	4	4	4	4	
Coil length	(mm)	2311	2311	3226	3226	2311	2311	3226	3226	3073	3073	3658	3658	3658	4572	
Coil height	(mm)	1727	1727	1727	1727	1727	1727	1727	1727	1067	1067	1067	1067	1067	1067	
Number of rows	#	2	2	2	2	2	2	2	2	3	3	3	3	3	3	
Fins per foot	(fpf)	192	192	192	192	192	192	192	192	192	192	192	192	192	192	
Fan																
Quantity/circuit ¹	#	2	2	3	3	2	2	3	3	2	3	4	4	4		
Diameter	(mm)	732	732	732	732	732	732	732	732	732	732	732	732	732	732	
Airflow per fan	(m ³ /h)	15993	16005	15577	15585	15993	16005	15577	15585	16090	16093	15451	15454	15458	15451	
Power per motor	(kW)	1.2	1.2	1.2	1.2	1.2	1.2	1.2	1.2	1.2	1.2	1.2	1.2	1.2	1.2	
Motor RPM	(rpm)	840	840	840	840	840	840	840	840	840	840	840	840	840	840	
Tip speed	(m/s)	32	32	32	32	32	32	32	32	32	32	32	32	32	32	
General Unit																
Refrig circuits	#	1	1	1	1	2	2	2	2	2	2	2	2	2	2	
Capacity steps	%	50-100	50-100	50-100	43-100	25-50-75-100	25-50-75-100	25-50-75-100	21-43-71-100	25-50-75-100	22-44-72-100	25-50-75-100	23-45-73-100	25-50-75-100	15-31-46-62-81-100	
Refrig charge/circuit ¹	(kg)	14.5	15.4	21.8	21.8	14.5	14.5	22.9	21.8	33.6	35.4	36.7	41.5	39.0	50.8	
Oil charge /circuit ¹	(l)	6.6	6.6	13.4	13.4	6.6	6.6	13.4	13.4	13.4	13.4	13.4	13.9	14.4	22.0	
Min ambient - wide	(°C)	-18	-18	-18	-18	-18	-18	-18	-18	-18	-18	-18	-18	-18	-18	
Min ambient - high	(°C)					n/a						0	0	0	0	
Pump Package																
Avail head pressure ²	(kPa)	233.7	232.3	212.6	202.1	200.6	175.0	229.2	189.7	245.1	233.3	206.3	185.0	213.1	185.8	
Power	(HP)	5.0	5.0	5.0	5.0	5.0	5.0	7.6	7.6	10.2	10.2	10.2	10.2	15.2	15.2	
Expansion tank volume	(l)	18.9	18.9	18.9	18.9	18.9	18.9	18.9	18.9	22.7	22.7	22.7	22.7	22.7	22.7	
Partial Heat Recovery																
Water storage/circuit ¹	(l)	0.07	0.09	0.09	0.11	0.07	0.09	0.09	0.11	0.12	0.16	0.16	0.16	0.21	0.21	
Max flow	(l/s)	2.5	2.5	2.5	2.5	5.0	5.0	5.0	5.0	8.0	8.0	8.0	8.0	8.0	8.0	
Water connection	(mm)	38.1	38.1	38.1	38.1	38.1	38.1	38.1	38.1	63.5	63.5	63.5	63.5	63.5	63.5	

1. Data shown for circuit one only. The second circuit always matches.

2. Pump available head pressure is based on: 6.7/12.2°C evaporator with water, .01761 m²°C/kW, 35°C ambient and 0 m elevation.

Table 3. General Data - 50 Hz - IP

Size		20	26	30	35	40	52	60	70	80	90	100	110	120
Compressor														
Number #		2	2	2	2	4	4	4	4	4	4	4	4	4
Tonnage/circuit ¹		10+10	13+13	15+15	15+20	10+10	13+13	15+15	15+20	20+20	20+25	25+25	25+30	30+30
Evaporator														
Water storage (gal)		1.4	2.2	2.2	3.2	2.4	4.1	5.0	7.5	7.0	9.0	10.3	11.5	11.5
Min. flow (gpm)		25	32	36	41	48	62	71	83	97	109	123	133	142
Max. flow (gpm)		59	75	85	98	115	149	170	199	234	262	296	319	341
Water connection (in)		2	2.5	2.5	2.5	3	3	3	3	4	4	4	4	4
Condenser														
Quantity of coils #		1	1	1	1	2	2	2	2	4	4	4	4	4
Coil length (in)		91	91	127	127	91	91	127	127	121	121	144	144	144
Coil height (in)		68	68	68	68	68	68	68	68	42	42	42	42	42
Number of rows #		2	2	2	2	2	2	2	2	3	3	3	3	3
Fins per foot (fpf)		192	192	192	192	192	192	192	192	192	192	192	192	192
Fan														
Quantity #		2	2	3	3	4	4	6	6	6	6	8	8	8
Diameter (in)		28.8	28.8	28.8	28.8	28.8	28.8	28.8	28.8	28.8	28.8	28.8	28.8	28.8
Airflow/fan (cfm)		7796	7783	7587	7590	7795	7801	7587	7590	7827	7829	7503	7505	7506
Power/motor (kW)		0.8	0.8	0.8	0.8	0.8	0.8	0.8	0.8	0.8	0.8	0.8	0.8	0.8
Motor RPM (rpm)		700	700	700	700	700	700	700	700	700	700	700	700	700
Tip speed (ft/min)		5278	5278	5278	5278	5278	5278	5278	5278	5278	5278	5278	5278	5278
General Unit														
Refrig circuits #		1	1	1	1	2	2	2	2	2	2	2	2	2
Capacity steps %		50-100	50-100	50-100	43-100	25-50-75-100	25-50-75-100	25-50-75-100	21-43-71-100	25-50-75-100	22-44-72-100	25-50-75-100	23-45-73-100	25-50-75-100
Refrig charge/circuit ¹ (lbs)		34	34	48	48	32	32	48	48	74	74	82	86	84
Oil charge/circuit ¹ (gal)		1.7	1.7	3.5	3.5	1.7	1.7	3.5	3.5	3.5	3.5	3.5	3.7	3.8
Min ambient - wide (°F)		0	0	0	0	0	0	0	0	0	0	0	0	0
Min ambient - high (°F)						n/a						32	32	32
Partial Heat Recovery														
Water storage/circuit ¹ (gal)		0.02	0.02	0.02	.02	0.02	0.02	0.02	0.02	0.03	0.03	0.03	0.04	0.04
Max flow (gpm)		39	39	39	39	78	78	78	78	127	127	127	127	127
Water connection (in)		1.5	1.5	1.5	1.5	1.5	1.5	1.5	1.5	2.5	2.5	2.5	2.5	2.5

1. Data shown for circuit one only. The second circuits always matches.



General Data

Table 4. General Data - 50 Hz - SI

Size		20	26	30	35	40	52	60	70	80	90	100	110	120
Compressor														
Number #		2	2	2	2	4	4	4	4	4	4	4	4	4
Tonnage/circuit ¹		10+10	13+13	15+15	15+20	10+10	13+13	15+15	15+20	20+20	20+25	25+25	25+30	30+30
Evaporator														
Water storage (l)		5.3	8.3	8.3	12.1	9.1	15.5	18.9	28.4	26.5	34.1	39.0	43.5	43.5
Min. flow (l/s)		1.6	2.0	2.2	2.6	3.0	3.9	4.4	5.2	6.1	6.8	7.7	8.3	8.9
Max. flow (l/s)		3.7	4.8	5.4	6.2	7.3	9.4	10.8	12.6	14.8	16.5	18.7	20.2	21.6
Water connection (mm)		50.8	63.5	63.5	63.5	76.2	76.2	76.2	76.2	101.6	101.6	101.6	101.6	101.6
Condenser														
Quantity of coils #		1	1	1	1	2	2	2	2	4	4	4	4	4
Coil length (mm)		2311	2311	3226	3226	2311	2311	3226	3226	3073	3073	3658	3658	3658
Coil height (mm)		1727	1727	1727	1727	1727	1727	1727	1727	1067	1067	1067	1067	1067
Number of rows #		2	2	2	2	2	2	2	2	3	3	3	3	3
Fins per foot (fpf)		192	192	192	192	192	192	192	192	192	192	192	192	192
Fan														
Quantity #		2	2	3	3	4	4	6	6	6	6	8	8	8
Diameter (mm)		732	732	732	732	732	732	732	732	732	732	732	732	732
Airflow/fan (m ³ /h)		13245	13223	12890	12895	13244	13254	12890	12895	13298	13302	12748	12751	12753
Power/motor (kW)		0.8	0.8	0.8	0.8	0.8	0.8	0.8	0.8	0.8	0.8	0.8	0.8	0.8
Motor RPM (rpm)		700	700	700	700	700	700	700	700	700	700	700	700	700
Tip speed (m/s)		26.8	26.8	26.8	26.8	26.8	26.8	26.8	26.8	26.8	26.8	26.8	26.8	26.8
General Unit														
Refrig circuits #		1	1	1	1	2	2	2	2	2	2	2	2	2
Capacity steps %		50-100	50-100	50-100	43-100	25-50-75-100	25-50-75-100	25-50-75-100	21-43-71-100	25-50-75-100	22-44-72-100	25-50-75-100	23-45-73-100	25-50-75-100
Refrig charge/circuit ¹ (kg)		15.4	15.4	21.8	21.8	14.5	14.5	21.8	21.8	33.6	33.6	37.2	39.0	38.1
Oil charge/circuit ¹ (l)		6.6	6.6	13.4	13.4	6.6	6.6	13.4	13.4	13.4	13.4	13.4	13.9	14.4
Min ambient - wide (°C)		-18	-18	-18	-18	-18	-18	-18	-18	-18	-18	-18	-18	-18
Min ambient - high (°C)												0	0	0
Partial Heat Recovery														
Water storage/circuit ¹ (l)		0.07	0.07	0.09	0.09	0.07	0.07	0.09	0.09	0.12	0.12	0.12	0.16	0.16
Max flow (l/s)		2.5	2.5	2.5	2.5	5.0	5.0	5.0	5.0	8.0	8.0	8.0	8.0	8.0
Water connection (mm)		38.1	38.1	38.1	38.1	38.1	38.1	38.1	38.1	63.5	63.5	63.5	63.5	63.5

1. Data shown for circuit one only. The second circuit always matches.



Performance Data

Table 5. Performance Data - 60 Hz - I-P units

Evaporator Leaving Temperature (°F)	Condenser Ambient Temperature (°F)												
	Unit Size	85			95			105			115		
		Tons	kW Input	EER	Tons	kW Input	EER	Tons	kW Input	EER	Tons	kW Input	EER
42	20 tons	20.1	20.8	11.6	18.9	22.7	10	17.7	24.7	8.6	16.3	27	7.2
	26 tons	25.9	27.3	11.4	24.3	29.9	9.7	22.5	32.8	8.2	20.7	35.8	6.9
	30 tons	29	30.2	11.5	27.2	33.2	9.9	25.4	36.5	8.3	23.4	40	7
	35 tons	34.1	36	11.4	32	39.5	9.7	29.7	43.4	8.2	27.4	47.6	6.9
	40 tons	39.1	41.6	11.3	36.9	45.4	9.8	34.4	49.6	8.3	31.7	54.2	7
	52 tons	51.3	54.8	11.2	47.9	60	9.6	44.4	65.8	8.1	40.7	71.9	6.8
	60 tons	58.9	60.6	11.7	55.2	66.5	10	51.3	73.1	8.4	47.3	80.1	7.1
	70 tons	70	73	11.5	65.4	80.1	9.8	60.6	87.8	8.3	55.8	96	7
	80 tons	80.5	80.9	11.9	75.6	89.2	10.2	70.3	98.3	8.6	64.8	108.1	7.2
	90 tons	90.3	93.1	11.6	84.5	102.1	9.9	78.4	111.9	8.4	72	122.4	7.1
	100 tons	101.9	103.9	11.8	95.6	113.5	10.1	88.8	124	8.6	81.7	135.3	7.2
	110 tons	110.7	116.2	11.4	103.6	126.9	9.8	96.1	138.4	8.3	88.3	150.8	7
	120 tons	119.9	128.4	11.2	112.1	140.1	9.6	103.8	152.7	8.2	95.2	166.2	6.9
130 tons	130	132.6	11.8	121.9	145.5	10.1	113.3	159.7	8.5	104.3	174.8	7.2	
44	20 tons	20.8	21	11.9	19.6	22.9	10.3	18.3	24.9	8.8	16.9	27.2	7.4
	26 tons	26.8	27.6	11.7	25.1	30.2	10	23.2	33	8.4	21.3	36.1	7.1
	30 tons	30	30.4	11.8	28.2	33.4	10.1	26.3	36.7	8.6	24.3	40.2	7.2
	35 tons	35.3	36.3	11.7	33.1	39.8	10	30.7	43.7	8.4	28.3	47.9	7.1
	40 tons	40.6	42	11.6	38.2	45.8	10	35.6	50	8.6	32.9	54.6	7.2
	52 tons	53	55.4	11.5	49.5	60.6	9.8	45.9	66.3	8.3	42	72.5	7
	60 tons	61	61.1	12	57.2	67.1	10.2	53.1	73.6	8.7	49	80.5	7.3
	70 tons	72.4	73.8	11.8	67.7	80.8	10.1	62.7	88.5	8.5	57.7	96.7	7.2
	80 tons	83.3	81.6	12.2	78.2	89.9	10.4	72.7	99	8.8	67.1	108.8	7.4
	90 tons	93.3	94	11.9	87.4	103	10.2	81	112.8	8.6	74.5	123.2	7.3
	100 tons	105.5	104.8	12.1	98.9	114.4	10.4	91.9	124.9	8.8	84.5	136.1	7.5
	110 tons	114.4	117.3	11.7	107.1	128	10	99.3	139.5	8.5	91.3	151.8	7.2
	120 tons	123.9	129.6	11.5	115.8	141.3	9.8	107.2	154	8.4	98.5	167.4	7.1
130 tons	134.4	133.9	12	126.1	146.8	10.3	117.1	160.9	8.7	107.9	176	7.4	



Performance Data

Table 5. Performance Data - 60 Hz - I-P units

Evaporator Leaving Temperature (°F)	Condenser Ambient Temperature (°F)												
	Unit Size	85			95			105			115		
		Tons	kW Input	EER	Tons	kW Input	EER	Tons	kW Input	EER	Tons	kW Input	EER
46	20 tons	21.5	21.2	12.2	20.3	23.1	10.6	18.9	25.1	9	17.5	27.4	7.6
	26 tons	27.6	27.9	11.9	25.9	30.4	10.2	24	33.3	8.6	22	36.3	7.3
	30 tons	31	30.6	12.2	29.1	33.6	10.4	27.2	36.9	8.8	25.1	40.4	7.5
	35 tons	36.4	36.6	11.9	34.2	40.2	10.2	31.8	44	8.7	29.3	48.2	7.3
	40 tons	42	42.4	11.9	39.6	46.2	10.3	36.9	50.4	8.8	34.1	55	7.4
	52 tons	54.7	56	11.7	51.1	61.2	10	47.4	66.9	8.5	43.4	73	7.1
	60 tons	63.1	61.6	12.3	59.2	67.6	10.5	55	74.1	8.9	50.8	81	7.5
	70 tons	74.8	74.5	12.1	70	81.6	10.3	64.9	89.2	8.7	59.7	97.4	7.4
	80 tons	86.1	82.4	12.5	80.8	90.7	10.7	75.2	99.8	9	69.3	109.6	7.6
	90 tons	96.4	94.9	12.2	90.3	103.9	10.4	83.7	113.7	8.8	77	124.1	7.4
	100 tons	109.1	105.7	12.4	102.3	115.3	10.6	95	125.8	9.1	87.4	137	7.7
	110 tons	118.3	118.4	12	110.7	129.1	10.3	102.6	140.6	8.8	94.4	152.9	7.4
	120 tons	127.9	130.9	11.7	119.6	142.6	10.1	110.7	155.2	8.6	101.7	168.6	7.2
130 tons	138.9	135.1	12.3	130.2	148	10.6	121	162.1	9	111.5	177.2	7.6	
48	20 tons	22.2	21.4	12.5	20.9	23.3	10.8	19.5	25.3	9.3	18	27.6	7.8
	26 tons	28.5	28.1	12.2	26.7	30.7	10.4	24.7	33.6	8.8	22.7	36.6	7.5
	30 tons	32	30.9	12.5	30.1	33.9	10.7	28.1	37.1	9.1	26	40.6	7.7
	35 tons	37.6	37	12.2	35.3	40.5	10.4	32.8	44.4	8.9	30.3	48.5	7.5
	40 tons	43.5	42.9	12.2	41	46.7	10.5	38.2	50.8	9	35.3	55.4	7.6
	52 tons	56.5	56.6	12	52.8	61.8	10.2	48.9	67.5	8.7	44.8	73.5	7.3
	60 tons	65.3	62.2	12.6	61.2	68.1	10.8	56.9	74.6	9.2	52.6	81.5	7.7
	70 tons	77.3	75.3	12.3	72.3	82.3	10.5	67	89.9	8.9	61.7	98	7.6
	80 tons	88.9	83.1	12.8	83.5	91.5	11	77.7	100.6	9.3	71.6	110.3	7.8
	90 tons	99.6	95.8	12.5	93.2	104.8	10.7	86.4	114.6	9	79.5	124.9	7.6
	100 tons	112.7	106.6	12.7	105.7	116.2	10.9	98.1	126.7	9.3	90.4	137.8	7.9
	110 tons	122.1	119.5	12.3	114.3	130.2	10.5	106	141.7	9	97.5	153.9	7.6
	120 tons	132	132.2	12	123.4	143.9	10.3	114.3	156.5	8.8	105	169.7	7.4
130 tons	143.4	136.3	12.6	134.5	149.3	10.8	125	163.3	9.2	115.2	178.4	7.8	

Table 5. Performance Data - 60 Hz - I-P units

Evaporator Leaving Temperature (°F)	Condenser Ambient Temperature (°F)												
	Unit Size	85			95			105			115		
		Tons	kW Input	EER	Tons	kW Input	EER	Tons	kW Input	EER	Tons	kW Input	EER
50	20 tons	23	21.6	12.8	21.6	23.5	11.1	20.2	25.5	9.5	18.6	27.8	8.1
	26 tons	29.4	28.4	12.4	27.5	31	10.6	25.5	33.8	9	23.4	36.8	7.6
	30 tons	33.1	31.1	12.8	31.1	34.1	10.9	29	37.4	9.3	26.8	40.9	7.9
	35 tons	38.8	37.3	12.5	36.4	40.8	10.7	33.9	44.7	9.1	31.3	48.8	7.7
	40 tons	45	43.3	12.5	42.4	47.1	10.8	39.6	51.3	9.3	36.5	55.8	7.9
	52 tons	58.2	57.2	12.2	54.4	62.4	10.5	50.4	68	8.9	46.3	74	7.5
	60 tons	67.4	62.7	12.9	63.3	68.7	11.1	58.9	75.1	9.4	54.4	81.9	8
	70 tons	79.8	76	12.6	74.6	83	10.8	69.2	90.6	9.2	63.8	98.7	7.7
	80 tons	91.8	83.9	13.1	86.2	92.2	11.2	80.2	101.3	9.5	74	111.1	8
	90 tons	102.7	96.7	12.7	96.1	105.7	10.9	89.1	115.5	9.3	82	125.7	7.8
	100 tons	116.3	107.5	13	109.1	117.1	11.2	101.3	127.5	9.5	93.3	138.6	8.1
	110 tons	126	120.7	12.5	117.9	131.3	10.8	109.4	142.7	9.2	100.6	154.9	7.8
	120 tons	136.1	133.5	12.2	127.2	145.2	10.5	117.8	157.7	9	108.3	170.9	7.6
130 tons	148	137.6	12.9	138.7	150.5	11.1	129	164.5	9.4	118.9	179.5	8	

1. Rated in accordance with AHRI Standard 550/590 based on sea level altitude, evaporator fouling factor of 0.00010°F·ft²h/Btu, evaporator temperature drop of 10°F and 380/460/575 voltage.
2. kW input is for compressors only.
3. EER = Energy Efficiency Ratio (Btu/watt-hour). Power inputs include: compressors, condenser fans, and control power.
4. Interpolation between points is permissible. Extrapolation is not permitted.
5. Performance based on TOPSS version 137. Consult Trane representative for performance at temperatures outside of the ranges shown.

Table 6. Part Load Performance - 60 Hz - I-P units

Unit Size	IPLV	100%			75%			50%			25%		
	EER	Tons	kW input	EER	Tons	kW input	EER	Tons	kW input	EER	Tons	kW input	EER
20 tons	14.2	19.6	22.9	10.3	14.7	13.7	12.9	9.8	8.0	14.7	4.9	3.5	16.7
26 tons	15.1	25.1	30.2	10.0	18.8	16.8	13.4	12.5	9.3	16.1	6.3	4.4	17.2
30 tons	15.0	28.2	33.4	10.1	21.1	19.0	13.3	14.1	10.5	16.2	7.1	4.9	17.2
35 tons	15.2	33.1	39.8	10.0	24.8	22.6	13.1	16.5	11.9	16.7	8.3	5.6	17.6
40 tons	13.8	38.2	45.8	10.0	28.7	27.6	12.5	19.1	15.9	14.4	9.6	7.0	16.4
52 tons	15.1	49.5	60.6	9.8	37.2	33.6	13.3	24.8	18.2	16.4	12.4	8.6	17.3
60 tons	15.3	57.2	67.1	10.2	42.9	38.3	13.4	28.6	20.6	16.6	14.3	9.8	17.6
70 tons	15.6	67.7	80.8	10.1	50.8	46.1	13.2	33.8	23.6	17.2	16.9	11.1	18.3
80 tons	15.6	78.2	89.9	10.4	58.6	50.7	13.9	39.1	27.2	17.3	19.5	14.4	16.3
90 tons	15.8	87.4	103.0	10.2	65.5	57.8	13.6	43.7	29.5	17.8	21.8	15.5	16.9
100 tons	15.4	98.9	114.4	10.4	74.2	65.6	13.6	49.5	35.7	16.6	24.7	16.5	18.0
110 tons	15.3	107.1	128.0	10.0	80.3	72.9	13.2	53.6	38.5	16.7	26.8	17.7	18.2
120 tons	15.4	115.8	141.3	9.8	86.8	78.1	13.3	57.9	41.6	16.7	29.0	19.4	17.9
130 tons	16.6	126.1	146.8	10.3	94.5	79.0	14.4	63.0	42.6	17.8	31.5	18.6	20.3

1. IPLV values are rated in accordance with AHRI Standard 550/590.
2. EER and IPLV values include compressors, condenser fans, and control kW.
3. Performance is based on 380/460/575 voltage TOPSS version 137.



Performance Data

Table 7. Performance Data - 60 Hz - SI units

Evaporator Leaving Temperature (°C)	Condenser Ambient Temperature (°C)												
	30			35			40			45			
	Unit Size	kW Cooling	kW Input	COP	kW Cooling	kW Input	COP	kW Cooling	kW Input	COP	kW Cooling	kW Input	COP
7	20 tons	73.13	21.2	3.46	69.27	22.9	3.02	65.05	24.8	2.64	60.83	26.8	2.26
	26 tons	94.23	27.9	3.37	88.6	30.2	2.93	82.98	32.8	2.52	77	35.5	2.17
	30 tons	105.48	30.7	3.43	99.85	33.4	2.99	93.53	36.4	2.58	87.2	39.5	2.2
	35 tons	124.11	36.7	3.37	117.08	39.9	2.93	109.7	43.4	2.52	101.96	47.1	2.17
	40 tons	142.75	42.4	3.37	135.37	45.9	2.96	127.28	49.6	2.55	118.49	53.7	2.2
	52 tons	186.35	56	3.34	175.45	60.7	2.9	163.49	65.9	2.49	151.54	71.3	2.14
	60 tons	214.48	61.8	3.49	202.52	67.2	3.02	189.51	73	2.61	176.5	79.2	2.23
	70 tons	254.56	74.6	3.43	239.79	81	2.96	223.97	87.8	2.55	207.8	95.2	2.2
	80 tons	292.88	82.6	3.54	276.71	90.1	3.08	259.48	98.3	2.64	241.55	107	2.26
	90 tons	328.39	95	3.46	309.41	103.2	2.99	289.02	112	2.58	268.27	121.3	2.23
	100 tons	371.29	105.9	3.51	350.19	114.6	3.05	328.04	124	2.64	304.49	134	2.28
	110 tons	402.58	118.6	3.4	379.38	128.2	2.96	354.41	138.5	2.55	329.1	149.5	2.2
	120 tons	435.63	131	3.31	409.97	141.6	2.9	382.54	152.9	2.49	354.76	164.9	2.14
130 tons	472.9	135.3	3.49	446.18	147	3.05	418.05	159.7	2.61	388.52	173.2	2.26	
9	20 tons	77.7	21.6	3.6	73.48	23.3	3.16	69.27	25.1	2.75	64.34	27.1	2.37
	26 tons	99.5	28.4	3.51	93.88	30.7	3.05	87.55	33.3	2.64	81.22	36	2.26
	30 tons	111.81	31.1	3.6	105.83	33.9	3.13	99.5	36.8	2.69	92.82	39.9	2.31
	35 tons	131.5	37.3	3.51	124.11	40.5	3.05	116.03	44	2.64	108.29	47.6	2.28
	40 tons	152.24	43.2	3.51	144.16	46.7	3.08	135.37	50.4	2.69	126.22	54.5	2.31
	52 tons	197.25	57.1	3.46	185.64	61.8	2.99	173.34	66.9	2.58	160.68	72.3	2.23
	60 tons	228.19	62.7	3.63	215.18	68.1	3.16	201.82	73.9	2.72	188.11	80.1	2.34
	70 tons	270.03	76	3.54	254.21	82.3	3.08	237.68	89.1	2.67	220.8	96.4	2.28
	80 tons	310.81	83.9	3.69	293.59	91.5	3.22	275.3	99.6	2.75	256.32	108.3	2.37
	90 tons	347.73	96.7	3.6	327.69	104.8	3.13	306.24	113.6	2.69	284.44	122.8	2.31
	100 tons	393.79	107.5	3.66	371.64	116.2	3.19	347.73	125.6	2.78	323.47	135.5	2.37
	110 tons	426.49	120.6	3.54	401.88	130.2	3.08	375.51	140.5	2.67	348.79	151.4	2.31
	120 tons	461.3	133.3	3.46	433.87	143.9	3.02	405.04	155.2	2.61	375.86	167	2.26
130 tons	501.03	137.6	3.63	472.9	149.2	3.16	443.02	161.9	2.72	412.08	175.3	2.34	

1. Rated in accordance with AHRI Standard 550/590, based on sea level altitude, evaporator fouling factor of 0.01761 m²-°C/kW, evaporator temperature drop of 5°C and 380/460/575 voltage.
2. COP = Coefficient of Performance. Power inputs include: compressors, condenser fans, and control power.
3. kW input is for compressors only.
4. Interpolation between points is permissible. Extrapolation is not permitted.
5. Performance based on TOPSS version 137. Consult Trane representative for performance at temperatures outside of the ranges shown.

Table 8. Performance Data - 50 Hz - I-P units

Evaporator Leaving Temperature (°F)	Condenser Ambient Temperature (°F)												
	Unit Size	85			95			105			115		
		Tons	kW Input	EER	Tons	kW Input	EER	Tons	kW Input	EER	Tons	kW Input	EER
42	20 tons	17.1	16.4	12.5	16.1	18	10.7	15	19.8	9.1	13.8	21.8	7.6
	26 tons	21.9	21.6	12.1	20.5	23.9	10.3	18.9	26.4	8.6	17.3	29.1	7.1
	30 tons	24.7	24.4	12.2	23.2	26.9	10.4	21.5	29.7	8.7	19.8	32.7	7.3
	35 tons	28.6	28.9	11.9	26.8	32	10.1	24.9	35.4	8.4	22.8	39.1	7
	40 tons	33.1	32.7	12.1	31.1	36	10.4	29	39.6	8.8	26.7	43.5	7.4
	52 tons	43.2	43.3	12	40.3	47.9	10.1	37.2	52.9	8.4	34	58.3	7
	60 tons	49.6	49	12.1	46.4	54	10.3	43.1	59.6	8.7	39.5	65.8	7.2
	70 tons	58.3	58.2	12	54.5	64.3	10.2	50.4	71	8.5	46.1	78.3	7.1
	80 tons	68.1	65.4	12.5	63.8	72.6	10.5	59.2	80.6	8.8	54.4	89.2	7.3
	90 tons	76.6	75.1	12.2	71.6	82.9	10.4	66.2	91.3	8.7	60.6	100.3	7.3
	100 tons	86.6	83.9	12.4	81.1	92.2	10.6	75.1	101.2	8.9	68.8	110.9	7.5
	110 tons	93.7	92	12.2	87.6	101.1	10.4	81.1	110.9	8.8	74.2	121.3	7.3
120 tons	100.2	101.2	11.9	93.6	111.2	10.1	86.5	121.8	8.5	79.2	133.1	7.1	
44	20 tons	17.7	16.6	12.8	16.6	18.2	11	15.5	20	9.3	14.3	21.9	7.8
	26 tons	22.6	21.9	12.4	21.2	24.1	10.5	19.6	26.6	8.8	17.9	29.3	7.3
	30 tons	25.6	24.5	12.5	24	27	10.7	22.3	29.8	9	20.5	32.9	7.5
	35 tons	29.6	29.2	12.2	27.8	32.2	10.3	25.7	35.6	8.7	23.7	39.3	7.2
	40 tons	34.3	33	12.5	32.3	36.3	10.7	30	39.9	9	27.7	43.8	7.6
	52 tons	44.6	43.8	12.2	41.7	48.3	10.3	38.5	53.3	8.7	35.2	58.7	7.2
	60 tons	51.4	49.4	12.5	48.1	54.4	10.6	44.7	60	8.9	41	66.1	7.4
	70 tons	60.4	58.7	12.3	56.4	64.8	10.4	52.2	71.5	8.8	47.8	78.7	7.3
	80 tons	70.5	66	12.8	66.1	73.2	10.8	61.3	81.2	9.1	56.4	89.8	7.5
	90 tons	79.2	75.8	12.5	74	83.6	10.6	68.5	92	8.9	62.7	101	7.5
	100 tons	89.6	84.6	12.7	83.9	92.9	10.8	77.8	101.9	9.2	71.3	111.5	7.7
	110 tons	96.9	92.9	12.5	90.6	101.9	10.7	83.9	111.7	9	76.8	122.1	7.5
120 tons	103.6	102.3	12.2	96.7	112.2	10.3	89.4	122.8	8.7	81.9	134.1	7.3	
46	20 tons	18.3	16.7	13.2	17.2	18.3	11.3	16	20.1	9.6	14.8	22.1	8
	26 tons	23.4	22.1	12.7	21.9	24.3	10.8	20.2	26.8	9	18.5	29.5	7.5
	30 tons	26.5	24.7	12.9	24.8	27.2	11	23.1	30	9.2	21.3	33	7.7
	35 tons	30.6	29.4	12.5	28.7	32.5	10.6	26.6	35.9	8.9	24.5	39.5	7.4
	40 tons	35.6	33.3	12.8	33.4	36.6	11	31.1	40.2	9.3	28.7	44.1	7.8
	52 tons	46.1	44.3	12.5	43.1	48.8	10.6	39.8	53.8	8.9	36.3	59.1	7.4
	60 tons	53.2	49.8	12.8	49.9	54.8	10.9	46.3	60.4	9.2	42.5	66.5	7.7
	70 tons	62.5	59.3	12.6	58.4	65.3	10.7	54	72	9	49.5	79.2	7.5
	80 tons	73	66.6	13.2	68.4	73.8	11.1	63.5	81.7	9.3	58.4	90.3	7.8
	90 tons	81.9	76.5	12.8	76.5	84.3	10.9	70.8	92.7	9.2	64.9	101.6	7.7
	100 tons	92.7	85.3	13	86.8	93.6	11.1	80.5	102.6	9.4	73.8	112.2	7.9
	110 tons	100.2	93.8	12.8	93.7	102.8	10.9	86.7	112.6	9.2	79.4	122.9	7.8
120 tons	107	103.3	12.4	99.9	113.3	10.6	92.4	123.9	8.9	84.7	135	7.5	



Performance Data

Table 8. Performance Data - 50 Hz - I-P units

Evaporator Leaving Temperature (°F)	Condenser Ambient Temperature (°F)												
	Unit Size	85			95			105			115		
		Tons	kW Input	EER	Tons	kW Input	EER	Tons	kW Input	EER	Tons	kW Input	EER
48	20 tons	19	16.9	13.5	17.8	18.5	11.6	16.6	20.3	9.8	15.3	22.2	8.2
	26 tons	24.1	22.3	13	22.6	24.6	11	20.9	27.1	9.2	19.1	29.7	7.7
	30 tons	27.4	24.9	13.2	25.7	27.4	11.3	23.9	30.2	9.5	22	33.2	8
	35 tons	31.7	29.7	12.8	29.7	32.7	10.9	27.5	36.1	9.2	25.3	39.8	7.6
	40 tons	36.9	33.7	13.1	34.6	36.9	11.3	32.3	40.5	9.5	29.7	44.4	8
	52 tons	47.7	44.8	12.8	44.5	49.3	10.8	41.1	54.2	9.1	37.6	59.5	7.6
	60 tons	55.1	50.2	13.2	51.6	55.2	11.2	47.9	60.8	9.5	44.1	66.8	7.9
	70 tons	64.6	59.8	13	60.3	65.9	11	55.8	72.5	9.2	51.2	79.7	7.7
	80 tons	75.5	67.2	13.5	70.7	74.4	11.4	65.6	82.3	9.6	60.4	90.9	8
	90 tons	84.6	77.2	13.2	79.1	85	11.2	73.2	93.4	9.4	67.1	102.3	7.9
	100 tons	95.8	86	13.4	89.8	94.3	11.4	83.2	103.3	9.7	76.3	112.9	8.1
	110 tons	103.5	94.6	13.1	96.7	103.7	11.2	89.5	113.5	9.5	82.1	123.8	8
120 tons	110.4	104.4	12.7	103.1	114.3	10.8	95.3	124.9	9.2	87.4	136	7.7	
50	20 tons	19.6	17	13.8	18.4	18.6	11.8	17.1	20.4	10.1	15.8	22.4	8.5
	26 tons	24.9	22.6	13.2	23.3	24.8	11.2	21.5	27.3	9.5	19.7	29.9	7.9
	30 tons	28.3	25	13.5	26.5	27.6	11.6	24.7	30.3	9.8	22.8	33.4	8.2
	35 tons	32.7	29.9	13.1	30.6	33	11.1	28.4	36.3	9.4	26.2	40	7.9
	40 tons	38.2	34	13.5	35.9	37.3	11.5	33.4	40.9	9.8	30.8	44.8	8.3
	52 tons	49.2	45.3	13	45.9	49.8	11.1	42.4	54.7	9.3	38.8	60	7.8
	60 tons	57	50.6	13.5	53.4	55.6	11.5	49.6	61.2	9.7	45.6	67.2	8.1
	70 tons	66.7	60.4	13.3	62.3	66.4	11.3	57.7	73.1	9.5	53	80.2	7.9
	80 tons	78	67.8	13.8	73	75	11.7	67.8	82.9	9.8	62.4	91.4	8.2
	90 tons	87.3	77.9	13.5	81.6	85.7	11.4	75.5	94.1	9.6	69.3	102.9	8.1
	100 tons	99	86.7	13.7	92.7	95	11.7	85.9	104	9.9	78.9	113.6	8.3
	110 tons	106.8	95.5	13.4	99.8	104.6	11.5	92.4	114.3	9.7	84.8	124.6	8.2
120 tons	113.9	105.5	13	106.3	115.4	11.1	98.3	126	9.4	90.2	137	7.9	

1. Rated in accordance with AHRI Standard 550/590 based on sea level altitude, evaporator fouling factor of 0.00010°F·ft²h/Btu, and evaporator temperature drop of 10°F.
2. kW input is for compressors only.
3. EER = Energy Efficiency Ratio (Btu/watt-hour). Power inputs include: compressors, condenser fans, and control power.
4. Interpolation between points is permissible. Extrapolation is not permitted.
5. Performance based on TOPSS version 137. Consult Trane representative for performance at temperatures outside of the ranges shown.

Table 9. Part Load Performance - 50 Hz - I-P units

Unit Size	IPLV		100%		75%		50%		25%				
	EER	Tons	kW input	EER	Tons	kW input	EER	Tons	kW input	EER	Tons	kW input	EER
20 tons	16.1	16.6	18.2	11.0	12.5	10.6	14.2	8.3	5.8	17.3	4.2	2.7	18.6
26 tons	16.4	21.2	24.1	10.5	15.9	13.2	14.5	10.6	7.1	17.8	5.3	3.4	18.5
30 tons	16.1	24.0	27.0	10.7	18.0	15.4	14.1	12.0	8.1	17.8	6.0	4.2	17.3
35 tons	16.2	27.8	32.2	10.3	20.8	18.2	13.7	13.9	9.2	18.2	6.9	4.8	17.5
40 tons	15.3	32.3	36.3	10.7	24.2	21.3	13.6	16.1	11.9	16.3	8.1	5.4	18.0
52 tons	16.4	41.7	48.3	10.3	31.3	26.3	14.2	20.8	13.9	17.9	10.4	6.7	18.6
60 tons	15.7	48.1	54.4	10.6	36.1	31.1	13.9	24.1	16.9	17.1	12.0	8.3	17.4
70 tons	16.5	56.4	64.8	10.4	42.3	36.7	13.8	28.2	18.2	18.6	14.1	9.3	18.3
80 tons	16.6	66.1	73.2	10.8	49.5	40.5	14.7	33.0	21.3	18.6	16.5	11.8	16.8
90 tons	16.9	74.0	83.6	10.6	55.5	46.2	14.4	37.0	23.1	19.2	18.5	12.7	17.4
100 tons	16.4	83.9	92.9	10.8	63.0	52.5	14.4	42.0	28.2	17.9	21.0	13.4	18.8
110 tons	16.5	90.6	101.9	10.7	68.0	57.4	14.2	45.3	30.0	18.1	22.6	14.2	19.2
120 tons	16.8	96.7	112.2	10.3	72.5	60.8	14.3	48.4	31.3	18.5	24.2	14.7	19.7

1. IPLV values are rated in accordance with AHRI Standard 550/590.
2. EER and IPLV values include compressors, condenser fans, and control kW.
3. Performance is based on 400 voltage 50 Hz TOPSS version 137.



Performance Data

Table 10. Performance Data - 50 Hz - SI units

Evaporator Leaving Temperature (°C)	Condenser Ambient Temperature (°C)												
	Unit Size	30			35			40			45		
		kW Cooling	kW Input	COP	kW Cooling	kW Input	COP	kW Cooling	kW Input	COP	kW Cooling	kW Input	COP
7	20 tons	62.23	16.7	3.72	59.07	18.2	3.22	55.2	19.8	2.78	51.33	21.6	2.37
	26 tons	79.46	22.1	3.6	74.89	24.2	3.1	69.97	26.4	2.64	64.69	28.8	2.23
	30 tons	90.01	24.8	3.63	85.09	27.1	3.13	79.46	29.6	2.69	73.84	32.3	2.28
	35 tons	104.07	29.5	3.51	98.1	32.3	3.05	91.77	35.3	2.61	85.09	38.6	2.2
	40 tons	120.95	33.4	3.6	114.27	36.3	3.13	107.24	39.6	2.69	99.85	43.1	2.31
	52 tons	157.17	44.3	3.54	147.67	48.4	3.05	137.48	52.9	2.61	126.93	57.7	2.2
	60 tons	180.72	50	3.63	170.53	54.5	3.13	159.63	59.5	2.67	148.02	64.9	2.28
	70 tons	212.37	59.4	3.57	199.71	64.9	3.08	186.35	70.9	2.64	172.64	77.4	2.23
	80 tons	248.23	66.8	3.72	233.81	73.3	3.19	218.7	80.5	2.72	203.22	88.1	2.31
	90 tons	278.82	76.7	3.63	261.94	83.7	3.13	244.36	91.3	2.67	226.43	99.3	2.28
	100 tons	315.39	85.5	3.69	297.1	93	3.19	277.76	101.1	2.75	257.02	109.7	2.34
	110 tons	341.05	93.9	3.63	321.01	102.1	3.13	299.21	110.9	2.69	277.06	120.2	2.31
120 tons	364.26	103.4	3.51	342.46	112.4	3.05	319.25	122	2.61	295.34	132	2.23	
9	20 tons	66.1	17	3.9	62.58	18.5	3.4	58.72	20.1	2.93	54.5	21.8	2.49
	26 tons	84.38	22.5	3.75	79.11	24.6	3.22	73.84	26.8	2.75	68.21	29.2	2.34
	30 tons	95.64	25.1	3.81	90.36	27.4	3.31	84.74	29.9	2.84	78.76	32.6	2.4
	35 tons	110.75	30	3.69	104.43	32.7	3.19	97.39	35.7	2.72	90.71	39	2.31
	40 tons	128.69	34	3.78	121.65	36.9	3.31	114.27	40.2	2.84	106.18	43.6	2.43
	52 tons	166.66	45.2	3.69	156.46	49.3	3.16	145.56	53.7	2.72	134.66	58.5	2.31
	60 tons	192.68	50.6	3.81	181.43	55.2	3.28	169.82	60.2	2.81	157.87	65.6	2.4
	70 tons	225.73	60.4	3.75	212.01	65.9	3.22	197.95	71.8	2.75	183.54	78.3	2.34
	80 tons	263.7	67.9	3.9	248.58	74.4	3.34	232.41	81.5	2.84	215.88	89.1	2.43
	90 tons	295.7	77.9	3.78	278.12	85	3.28	259.48	92.5	2.81	240.14	100.5	2.4
	100 tons	335.07	86.8	3.87	315.74	94.3	3.34	294.99	102.4	2.87	273.19	110.9	2.46
	110 tons	361.44	95.5	3.78	340	103.7	3.28	317.49	112.5	2.81	293.94	121.7	2.4
120 tons	385.71	105.4	3.66	362.5	114.3	3.16	337.89	123.8	2.72	312.92	133.8	2.34	

1. Rated in accordance with AHRI Standard 550/590, based on sea level altitude, evaporator fouling factor of 0.01761 m²-°C/kW, and evaporator temperature drop of 5°C.

2. COP = Coefficient of Performance. Power inputs include: compressors, condenser fans, and control power.

3. kW input is for compressors only.

4. Interpolation between points is permissible. Extrapolation is not permitted.

5. Performance based on TOPSS version 137. Consult Trane representative for performance at temperatures outside of the ranges shown.

Controls

LCD Touch-Screen Display with Multi-Language Support

The standard DynaView display provided with the Trane CH530 control panel features an LCD touch-screen that is navigated by file tabs. This is an advanced interface that allows the user to access any important information concerning setpoints, active temperatures, modes, electrical data, pressure, and diagnostics. It uses full text display available in 19 languages.

Display Features Include:

- LCD touch-screen with LED backlighting, for scrolling access to input and output operating information
- Single-screen, folder/tab-style display of all available information on individual components (evaporator, condenser, compressor, etc.)
- Password entry/lockout system to enable or disable display
- Automatic and immediate stop capabilities for standard or immediate manual shutdown
- Fast, easy access to available chiller data in tabbed format, including:
 - Modes of operation, including normal cooling as well as ice making
 - Water temperatures and setpoints
 - Loading and limiting status and setpoints
 - Outdoor air temperature
 - Start/stop differential timers
 - Pump status and override
 - Chilled water reset settings
- Optional external setpoints, including:
 - Chilled water, demand limit, ice building

Reports, listed on a single tabbed screen for easy access, including:

- ASHRAE, containing all guideline 3 report information
- Evaporator, condenser, compressor

Evaporator, condenser, and compressor reports containing all operational information on individual components, including:

- Water temperatures, refrigerant pressures, temperatures, and approach
- Flow switch status, EXV position, compressor starts and run-time

Alarm and diagnostic information, including:

- Flashing alarms with touch-screen button for immediate address of alarm condition
- Scrollable list of last ten active diagnostics
- Specific information on applicable diagnostic from list of over one-hundred
- Automatic or manual resetting diagnostic types

Adaptive Controls

Adaptive Controls directly sense the control variables that govern the operation of the chiller: evaporator pressure and condenser pressure. When any one of these variables approaches a limit condition when damage may occur to the unit or shutdown on a safety, Adaptive Controls takes corrective action to avoid shutdown and keep the chiller operating. This happens through combined actions of compressor and/or fan staging. Whenever possible, the chiller is allowed to continue making chilled water. This keeps cooling capacity available until the problem can be solved. Overall, the safety controls help keep the building or process running and out of trouble.

Stand-Alone Controls

Single chillers installed in applications without a building management system is simple to install and control: only a remote auto/stop for scheduling is required for unit operation. Signals from the chilled-water pump contactor auxiliary, or a flow switch, are wired to the chilled-water flow interlock. Signals from a time clock or some other remote device are wired to the external auto/stop input.

- Auto/Stop - A job-site provided contact closure turns the unit on and off.
- External Interlock - A job-site provided contact opening wired to this input turns the unit off and requires a manual reset of the unit microcomputer. This closure is typically triggered by a job-site provided system such as a fire alarm.

Time of Day Scheduling

Time of day scheduling allows the customer to perform simple chiller scheduling without the need for a building automation system.

This feature allows the user to set ten events in a seven day time period. For each event the user can specify an activation time and the days of the week the event is active. Any available setpoints can be specified for each event, such as the leaving chilled water temperature (standard) and the demand limit setpoint (optional if ordered).

Required features:

- Time of day scheduling (selectable option with chiller)

Additional options that if ordered may be incorporated into the scheduling:

- External chilled water setpoint, external demand limit setpoint
- Ice-making initiation

Hardwire Points

Microcomputer controls allow simple interface with other control systems, such as time clocks, building automation systems, and ice storage systems via hardwire points. This means you have the flexibility to meet job requirements while not having to learn a complicated control system.

Remote devices are wired from the control panel to provide auxiliary control to a building automation system. Inputs and outputs can be communicated via a typical 4–20 mA electrical signal, an equivalent 2–10 Vdc signal, or by utilizing contact closures.

This setup has the same features as a stand-alone water chiller, with the possibility of having additional optional features:

- Ice making control
- External chilled water setpoint, external demand limit setpoint
- Chilled water temperature reset
- Programmable relays - available outputs are: alarm-latching, alarm-auto reset, general alarm, warning, chiller limit mode, compressor running, and Tracer control

BACnet Interface

BACnet interface capabilities are available, with communication link via single twisted-pair wiring to a factory-installed and tested communication board.

Required features:

- BACnet Interface (selectable option with chiller)

BACnet is a data communication protocol for building automation and control networks developed by American Society of Heating, Refrigerating and Air-Conditioning Engineers (ASHRAE).

LonTalk LCI-C Interface

LonTalk (LCI-C) communications capabilities are available, with communication link via single twisted-pair wiring to factory-installed, tested communication board.

Required features:

- LonTalk/Tracer Summit Interface (selectable option with chiller)

LonTalk is a communications protocol developed by the Echelon Corporation. The LonMark association develops control profiles using the LonTalk communication protocol. LonTalk is a unit level communications protocol.

LonTalk Communications Interface for Chillers (LCI-C) provides a generic automation system with the LonMark chiller profile inputs/outputs. In addition to the standard points, Trane provides other commonly used network output variables for greater interoperability with any automation system. The complete reference list of Trane LonTalk points is available on the LonMark web site.

Trane controls or another vendor's system can use the predefined list of points with ease to give the operator a complete picture of how the system is running

Tracer Summit

The chiller plant control capabilities of the Trane Tracer Summit building automation system are unequaled in the industry. Trane's depth of experience in chillers and controls makes us a well-qualified choice for automation of chiller plants using air-cooled CGAM chillers. Our chiller plant automation software is fully pre-engineered and tested.

Required features:

- LonTalk/Tracer Summit Interface (selectable option with chiller)
- Building Control Unit (external device required)

Energy Efficiency

- Sequences starting of chillers to optimize the overall chiller plant energy efficiency
 - Individual chillers operate as base, peak, or swing based on capacity and efficiency
 - Automatically rotates individual chiller operation to equalize runtime and wear between chillers.
 - Evaluates and selects the lowest energy consumption alternative from an overall system perspective.

Regulatory Compliance Documentation

- Gathers information and generates the reports mandated in ASHRAE Guideline 3.

Easy Operation and Maintenance

- Remote monitoring and control
- Displays both current operation conditions and scheduled automated control actions
- Concise reports assist in planning for preventative maintenance and verifying performance
- Alarm notification and diagnostic messages aid in quick and accurate troubleshooting

Tracer SC

The Tracer SC system controller acts as the central coordinator for all individual equipment devices on a Tracer building automation system. The Tracer SC scans all unit controllers to update information and coordinate building control, including building subsystems such as VAV and chiller water systems. With this system option, the full breadth of Trane’s HVAC and controls experience are applied to offer solutions to many facility issues. The LAN allows building operators to manage these varied components as one system from any personal computer with web access. The benefits of this system are:

- Improved usability with automatic data collection, enhanced data logging, easier to create graphics, simpler navigation, pre-programmed scheduling, reporting, and alarm logs.
- Flexible technology allows for system sizes from 30-120 unit controllers with any combination of LonTalk or BACnet unit controllers.
- LEED certification through site commissioning report, energy data collection measurement, optimizing energy performance, and maintaining indoor air quality.

Energy savings programs include: fan pressure optimization, ventilation reset, and chiller plant control (adds and subtracts chillers to meet cooling loads).

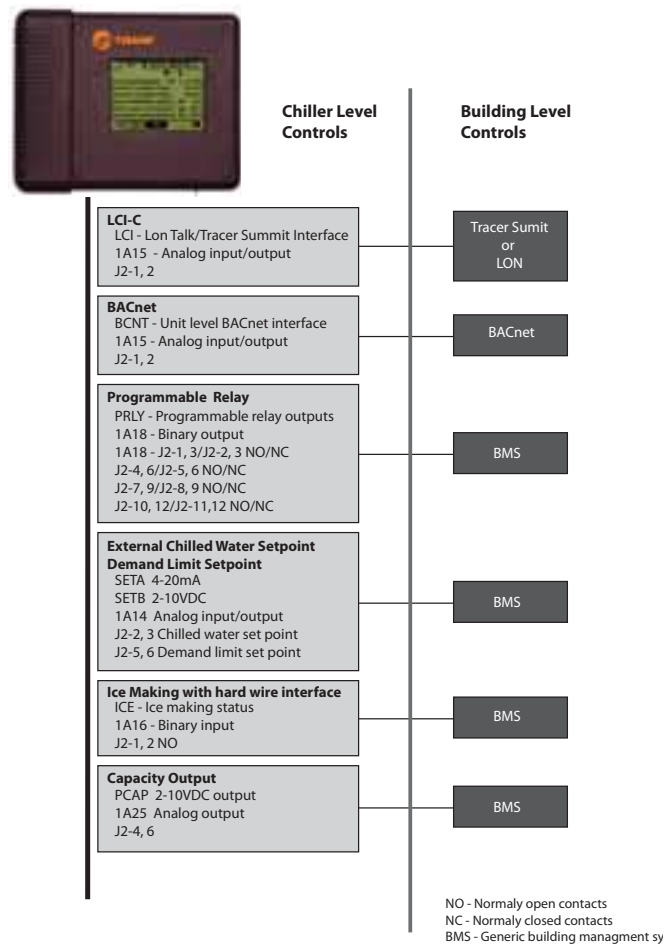



Electrical

Table 11. Electrical Data - 60 Hz

Unit Size	Rated Power	Number Circuits	Qty Comp	Qty Fans	Fan Motor Power (kw)	Cond Fan FLA	Compressor RLA ¹	Compressor LRA ²	No pump		Pump	
									MCA	MOPD	MCA	MOP
20	208/60/3	1	2	2	1	6.2	39-39	267-267	106	125	122	150
	230/60/3	1	2	2	1	6.7	39-39	267-267	106	125	122	150
	380/60/3	1	2	2	1	3.7	22-22	160-160	60	80	n/a	
	460/60/3	1	2	2	1	3.2	19-19	142-142	51	60	64	80
	575/60/3	1	2	2	1	2.6	15-15	103-103	42	50	52	60
26	208/60/3	1	2	2	1	6.2	51-51	315-315	131	175	148	175
	230/60/3	1	2	2	1	6.7	44-44	315-315	117	150	134	175
	380/60/3	1	2	2	1	3.7	26-26	177-177	69	90	n/a	
	460/60/3	1	2	2	1	3.2	21-21	158-158	56	70	69	80
	575/60/3	1	2	2	1	2.6	19-19	126-126	50	60	59	70
30	208/60/3	1	2	3	1	6.2	53-53	320-320	143	175	160	200
	230/60/3	1	2	3	1	6.7	54-54	320-320	146	175	153	200
	380/60/3	1	2	3	1	3.7	31-31	210-210	83	110	n/a	
	460/60/3	1	2	3	1	3.2	26-26	160-160	70	90	83	100
	575/60/3	1	2	3	1	2.6	21-21	135-135	57	70	66	80
35	208/60/3	1	2	3	1	6.2	53-74	320-485	169	225	186	250
	230/60/3	1	2	3	1	6.7	54-67	320-485	162	225	175	225
	380/60/3	1	2	3	1	3.7	31-40	210-260	94	125	n/a	
	460/60/3	1	2	3	1	3.2	26-33	160-215	79	110	92	110
	575/60/3	1	2	3	1	2.6	21-26	135-175	64	90	73	90
40	208/60/3	2	4	4	1	6.2	39-39/39-39	267-267/267-267	197	225	214	250
	230/60/3	2	4	4	1	6.7	39-39/39-39	267-267/267-267	198	225	214	250
	380/60/3	2	4	4	1	3.7	22-22/22-22	160-160/160-160	112	125	n/a	
	460/60/3	2	4	4	1	3.2	19-19/19-19	142-142/142-142	95	110	108	125
	575/60/3	2	4	4	1	2.6	15-15/15-15	103-103/103-103	79	90	89	100
52	208/60/3	2	4	4	1	6.2	51-51/51-51	315-315/315-315	246	250	263	300
	230/60/3	2	4	4	1	6.7	44-44/44-44	315-315/315-315	220	250	237	250
	380/60/3	2	4	4	1	3.7	26-26/26-26	177-177/177-177	129	150	n/a	
	460/60/3	2	4	4	1	3.2	21-21/21-21	158-158/158-158	106	125	119	125
	575/60/3	2	4	4	1	2.6	19-19/19-19	126-126/126-126	93	110	103	110
60	208/60/3	2	4	6	1	6.2	53-53/53-53	320-320/320-320	269	300		
	230/60/3	2	4	6	1	6.7	50-50/50-50	320-320/320-320	259	300	n/a	
	380/60/3	2	4	6	1	3.7	31-31/31-31	210-210/210-210	157	175		
	460/60/3	2	4	6	1	3.2	26-26/26-26	160-160/160-160	132	150	148	150
	575/60/3	2	4	6	1	2.6	21-21/21-21	135-135/135-135	107	125	118	125
70	208/60/3	2	4	6	1	6.2	53-74/74-53	320-485/485-320	316	350		
	230/60/3	2	4	6	1	6.7	50-67/67-50	350-485/485-350	297	350	n/a	
	380/60/3	2	4	6	1	3.7	31-40/40-31	210-260/260-210	177	200		
	460/60/3	2	4	6	1	3.2	26-33/33-26	160-215/215-160	148	175	164	175
	575/60/3	2	4	6	1	2.6	21-26/26-21	135-175/175-135	120	125	131	150



Electrical

Table 11. Electrical Data - 60 Hz

Unit Size	Rated Power	Number Circuits	Qty Comp	Qty Fans	Fan Motor Power (kw)	Cond Fan FLA	Compressor RLA ¹	Compressor LRA ²	No pump		Pump	
									MCA	MOPD	MCA	MOP
80	208/60/3	2	4	6	1	6.2	74-74/74-74	485-485/485-485	358	400	388	450
	230/60/3	2	4	6	1	6.7	67-67/67-67	485-485/485-485	331	350	362	400
	380/60/3	2	4	6	1	3.7	40-40/40-40	260-260/260-260	194	225	n/a	
	460/60/3	2	4	6	1	3.2	33-33/33-33	215-215/215-215	162	175	186	200
	575/60/3	2	4	6	1	2.6	26-26/26-26	175-175/175-175	131	150	150	175
90	208/60/3	2	4	6	1	6.2	74-91/91-74	485-560/560-485	397	450	428	500
	230/60/3	2	4	6	1	6.7	67-85/85-67	485-560/560-485	370	450	401	450
	380/60/3	2	4	6	1	3.7	40-55/55-40	260-310/310-260	227	275	n/a	
	460/60/3	2	4	6	1	3.2	33-42/42-33	215-260/260-215	182	200	206	225
	575/60/3	2	4	6	1	2.6	26-34/34-26	175-210/210-175	149	175	168	200
100	208/60/3	2	4	8	1	6.2	91-91/91-91	560-560/560-560	444	500	475	500
	230/60/3	2	4	8	1	6.7	85-85/85-85	560-560/560-560	418	500	449	500
	380/60/3	2	4	8	1	3.7	55-55/55-55	310-310/310-310	263	300	n/a	
	460/60/3	2	4	8	1	3.2	42-42/42-42	260-260/260-260	206	225	230	250
	575/60/3	2	4	8	1	2.6	34-34/34-34	210-210/210-210	169	200	188	200
110	208/60/3	2	4	8	1	6.2	91-110/110-91	560-680/680-560	485	500	516	600
	230/60/3	2	4	8	1	6.7	85-109/109-85	560-680/680-560	473	500	504	600
	380/60/3	2	4	8	1	3.7	55-60/60-55	310-360/360-310	275	300	n/a	
	460/60/3	2	4	8	1	3.2	42-51/51-42	260-320/320-260	226	250	250	250
	575/60/3	2	4	8	1	2.6	34-39/39-34	210-235/235-210	179	200	198	225
120	208/60/3	2	4	8	1	6.2	110-110/110-110	680-680/680-680	521	600	n/a	
	230/60/3	2	4	8	1	6.7	109-109/109-109	680-680/680-680	522	600	568	600
	380/60/3	2	4	8	1	3.7	60-60/60-60	360-360/360-360	285	300	n/a	
	460/60/3	2	4	8	1	3.2	51-51/51-51	320-320/320-320	244	250	268	300
	575/60/3	2	4	8	1	2.6	39-39/39-39	235-235/235-235	188	225	207	225
130	208/60/3	2	6	10	1	6.2	74-74-91/91-74-74	485-485-560/ 560-485-485	569	600	n/a	
	230/60/3	2	6	10	1	6.7	67-67-85/85-67-67	485-485-560/ 560-485-485	531	600	578	600
	380/60/3	2	6	10	1	3.7	40-40-55/55-40-40	260-260-310/ 310-260-260	321	350	n/a	
	460/60/3	2	6	10	1	3.2	33-33-42/42-33-33	215-215-260/ 260-215-215	261	300	285	300
	575/60/3	2	6	10	1	2.6	26-26-34/34-26-26	175-175-210/ 210-175-175	212	225	231	250

1. RLA - Rated Load Amps - Rated in accordance with UL Standard 1995.
2. LRA - Locked Rotor Amps - Based on full winding starts.
3. MCA - Minimum Circuit Ampacity - 125 percent of largest compressor RLA plus 100 percent of all other loads.
4. MOPD or Max fuse size - 225 percent of the largest compressor RLA plus all other loads.
5. Local codes may take precedence.
6. Voltage Utilization Range: +/- 10% of rated voltage
Rated voltage (use range): 208/60/3 (187.2-228.8), 230/60/3(208-254), 380/60/3 (342-418), 460/60/3 (414-506), 575/60/3 (516-633)
7. One separate 120/60/1, 15 amp customer provided power connection is required to power the heaters.
8. n/a - not available

Table 12. Lug Range Size - 60 Hz

Unit Size	Rated Power	Terminal Blocks	No Pump		Pump		
			Std Fault Ckt Breaker ¹	High Fault Ckt Breaker ¹	Terminal Blocks	Std Fault Ckt Breaker ¹	High Fault Ckt Breaker ¹
20	208/60/3	#6 - 350 MCM	#14 - 1/0	#14 - 1/0	#6 - 350 MCM	#6 - 350 MCM	#6 - 350 MCM
	230/60/3	#6 - 350 MCM	#14 - 1/0	#14 - 1/0	#6 - 350 MCM	#6 - 350 MCM	#6 - 350 MCM
	380/60/3	#6 - 350 MCM	#14 - 1/0	#14 - 1/0		n/a	
	460/60/3	#6 - 350 MCM	#14 - 1/0	#14 - 1/0	#6 - 350 MCM	#14 - 1/0	#14 - 1/0
	575/60/3	#6 - 350 MCM	#14 - 1/0	n/a	#6 - 350 MCM	#14 - 1/0	n/a
26	208/60/3	#6 - 350 MCM	#6 - 350 MCM	#6 - 350 MCM	#6 - 350 MCM	#6 - 350 MCM	#6 - 350 MCM
	230/60/3	#6 - 350 MCM	#6 - 350 MCM	#6 - 350 MCM	#6 - 350 MCM	#6 - 350 MCM	#6 - 350 MCM
	380/60/3	#6 - 350 MCM	#14 - 1/0	#14 - 1/0		n/a	
	460/60/3	#6 - 350 MCM	#14 - 1/0	#14 - 1/0	#6 - 350 MCM	#14 - 1/0	#14 - 1/0
	575/60/3	#6 - 350 MCM	#14 - 1/0	n/a	#6 - 350 MCM	#14 - 1/0	n/a
30	208/60/3	#6 - 350 MCM	#6 - 350 MCM	#6 - 350 MCM	#6 - 350 MCM	#6 - 350 MCM	#6 - 350 MCM
	230/60/3	#6 - 350 MCM	#6 - 350 MCM	#6 - 350 MCM	#6 - 350 MCM	#6 - 350 MCM	#6 - 350 MCM
	380/60/3	#6 - 350 MCM	#14 - 1/0	#14 - 1/0		n/a	
	460/60/3	#6 - 350 MCM	#14 - 1/0	#14 - 1/0	#6 - 350 MCM	#14 - 1/0	#14 - 1/0
	575/60/3	#6 - 350 MCM	#14 - 1/0	n/a	#6 - 350 MCM	#14 - 1/0	n/a
35	208/60/3	#6 - 350 MCM	#6 - 350 MCM	#6 - 350 MCM	#6 - 350 MCM	#6 - 350 MCM	#6 - 350 MCM
	230/60/3	#6 - 350 MCM	#6 - 350 MCM	#6 - 350 MCM	#6 - 350 MCM	#6 - 350 MCM	#6 - 350 MCM
	380/60/3	#6 - 350 MCM	#14 - 1/0	#14 - 1/0		n/a	
	460/60/3	#6 - 350 MCM	#14 - 1/0	#14 - 1/0	#6 - 350 MCM	#14 - 1/0	#14 - 1/0
	575/60/3	#6 - 350 MCM	#14 - 1/0	n/a	#6 - 350 MCM	#14 - 1/0	n/a
40	208/60/3	#4 - 500 MCM	3/0 - 500 MCM ²	3/0 - 500 MCM ²	#4 - 500 MCM	3/0 - 500 MCM ²	3/0 - 500 MCM ²
	230/60/3	#4 - 500 MCM	3/0 - 500 MCM ²	3/0 - 500 MCM ²	#4 - 500 MCM	3/0 - 500 MCM ²	3/0 - 500 MCM ²
	380/60/3	#4 - 500 MCM	#6 - 350 MCM	#6 - 350 MCM		n/a	
	460/60/3	#4 - 500 MCM	#6 - 350 MCM	#6 - 350 MCM	#4 - 500 MCM	#6 - 350 MCM	#6 - 350 MCM
	575/60/3	#4 - 500 MCM	#6 - 350 MCM	n/a	#4 - 500 MCM	#6 - 350 MCM	n/a
52	208/60/3	#4 - 500 MCM	3/0 - 500 MCM ²	3/0 - 500 MCM ²	#4 - 500 MCM	3/0 - 500 MCM ²	3/0 - 500 MCM ²
	230/60/3	#4 - 500 MCM	3/0 - 500 MCM ²	3/0 - 500 MCM ²	#4 - 500 MCM	3/0 - 500 MCM ²	3/0 - 500 MCM ²
	380/60/3	#4 - 500 MCM	#6 - 350 MCM	#6 - 350 MCM		n/a	
	460/60/3	#4 - 500 MCM	#6 - 350 MCM	#6 - 350 MCM	#4 - 500 MCM	#6 - 350 MCM	#6 - 350 MCM
	575/60/3	#4 - 500 MCM	#6 - 350 MCM	n/a	#4 - 500 MCM	#6 - 350 MCM	n/a
60	208/60/3	#4 - 500 MCM	3/0 - 500 MCM ²	3/0 - 500 MCM ²			
	230/60/3	#4 - 500 MCM	3/0 - 500 MCM ²	3/0 - 500 MCM ²		n/a	
	380/60/3	#4 - 500 MCM	#6 - 350 MCM	#6 - 350 MCM			
	460/60/3	#4 - 500 MCM	#6 - 350 MCM	#6 - 350 MCM	#4 - 500 MCM	#6 - 350 MCM	#6 - 350 MCM
	575/60/3	#4 - 500 MCM	#6 - 350 MCM	n/a	#4 - 500 MCM	#6 - 350 MCM	n/a
70	208/60/3	#4 - 500 MCM	3/0 - 500 MCM ²	3/0 - 500 MCM ²			
	230/60/3	#4 - 500 MCM	3/0 - 500 MCM ²	3/0 - 500 MCM ²		n/a	
	380/60/3	#4 - 500 MCM	3/0 - 500 MCM ²	3/0 - 500 MCM ²			
	460/60/3	#4 - 500 MCM	#6 - 350 MCM	#6 - 350 MCM	#4 - 500 MCM	#6 - 350 MCM	#6 - 350 MCM
	575/60/3	#4 - 500 MCM	#6 - 350 MCM	n/a	#4 - 500 MCM	#6 - 350 MCM	n/a



Electrical

Table 12. Lug Range Size - 60 Hz

Unit Size	Rated Power	Terminal Blocks	No Pump		Pump		
			Std Fault Ckt Breaker ¹	High Fault Ckt Breaker ¹	Terminal Blocks	Std Fault Ckt Breaker ¹	High Fault Ckt Breaker ¹
80	208/60/3	#4 - 500 MCM	3/0 - 500 MCM ²	3/0 - 500 MCM ²	#4 - 500 MCM ²	3/0-500 MCM ²	3/0-500 MCM ²
	230/60/3	#4 - 500 MCM	3/0 - 500 MCM ²	3/0 - 500 MCM ²	#4 - 500 MCM ²	3/0-500 MCM ²	3/0-500 MCM ²
	380/60/3	#4 - 500 MCM	3/0 - 500 MCM ²	3/0 - 500 MCM ²		n/a	
	460/60/3	#4 - 500 MCM	#6 - 350 MCM	#6 - 350 MCM	#4 - 500 MCM	3/0-500 MCM ²	3/0-500 MCM ²
	575/60/3	#4 - 500 MCM	#6 - 350 MCM	n/a	#4 - 500 MCM	#6 - 350 MCM	n/a
90	208/60/3	#4 - 500 MCM ²	3/0 - 500 MCM ²	3/0 - 500 MCM ²	#4 - 500 MCM ²	3/0-500 MCM ²	3/0-500 MCM ²
	230/60/3	#4 - 500 MCM ²	3/0 - 500 MCM ²	3/0 - 500 MCM ²	#4 - 500 MCM ²	3/0-500 MCM ²	3/0-500 MCM ²
	380/60/3	#4 - 500 MCM	3/0 - 500 MCM ²	3/0 - 500 MCM ²		n/a	
	460/60/3	#4 - 500 MCM	3/0 - 500 MCM ²	3/0 - 500 MCM ²	#6 - 350 MCM	3/0 - 500 MCM ²	3/0 - 500 MCM ²
	575/60/3	#4 - 500 MCM	#6 - 350 MCM	n/a	#6 - 350 MCM	#6 - 350 MCM	n/a
100	208/60/3	#4 - 500 MCM ²	3/0 - 500 MCM ²	3/0 - 500 MCM ²	#6 - 350 MCM	3/0-500 MCM ²	3/0-500 MCM ²
	230/60/3	#4 - 500 MCM ²	3/0 - 500 MCM ²	3/0 - 500 MCM ²	#6 - 350 MCM	3/0-500 MCM ²	3/0-500 MCM ²
	380/60/3	#4 - 500 MCM	3/0 - 500 MCM ²	3/0 - 500 MCM ²		n/a	
	460/60/3	#4 - 500 MCM	3/0 - 500 MCM ²	3/0 - 500 MCM ²	#6 - 350 MCM	3/0 - 500 MCM ²	3/0 - 500 MCM ²
	575/60/3	#4 - 500 MCM	3/0 - 500 MCM ²	n/a	#6 - 350 MCM	3/0 - 500 MCM ²	n/a
110	208/60/3	#4 - 500 MCM ²	3/0 - 500 MCM ²	3/0 - 500 MCM ²	#6 - 350 MCM	3/0-500 MCM ²	3/0-500 MCM ²
	230/60/3	#4 - 500 MCM ²	3/0 - 500 MCM ²	3/0 - 500 MCM ²	#6 - 350 MCM	3/0-500 MCM ²	3/0-500 MCM ²
	380/60/3	#4 - 500 MCM	3/0 - 500 MCM ²	3/0 - 500 MCM ²		n/a	
	460/60/3	#4 - 500 MCM	3/0 - 500 MCM ²	3/0 - 500 MCM ²	#6 - 350 MCM	3/0 - 500 MCM ²	3/0 - 500 MCM ²
	575/60/3	#4 - 500 MCM	3/0 - 500 MCM ²	n/a	#6 - 350 MCM	3/0 - 500 MCM ²	n/a
120	208/60/3	#4 - 500 MCM ²	3/0 - 500 MCM ²	3/0 - 500 MCM ²		n/a	
	230/60/3	#4 - 500 MCM ²	3/0 - 500 MCM ²	3/0 - 500 MCM ²	#6 - 350 MCM	3/0-500 MCM ²	3/0-500 MCM ²
	380/60/3	#4 - 500 MCM	3/0 - 500 MCM ²	3/0 - 500 MCM ²		n/a	
	460/60/3	#4 - 500 MCM	3/0 - 500 MCM ²	3/0 - 500 MCM ²	#6 - 350 MCM	3/0 - 500 MCM ²	3/0 - 500 MCM ²
	575/60/3	#4 - 500 MCM	3/0 - 500 MCM ²	n/a	#6 - 350 MCM	3/0 - 500 MCM ²	n/a
130	208/60/3	#4 - 500 MCM	3/0 - 500 MCM ²	3/0 - 500 MCM ²		n/a	
	230/60/3	#4 - 500 MCM ²	3/0 - 500 MCM ²	3/0 - 500 MCM ²	#4 - 500 MCM ²	3/0 - 500 MCM ²	3/0 - 500 MCM ²
	380/60/3	#4 - 500 MCM	3/0 - 500 MCM ²	3/0 - 500 MCM ²		n/a	
	460/60/3	#4 - 500 MCM	3/0 - 500 MCM ²	3/0 - 500 MCM ²	#4 - 500 MCM	3/0 - 500 MCM ²	3/0 - 500 MCM ²
	575/60/3	#4 - 500 MCM	3/0 - 500 MCM ²	n/a	#4 - 500 MCM	3/0 - 500 MCM ²	n/a

1. Optional circuit breaker and high fault circuit breaker.
2. Will accept two conduits per phase in this size.
3. Copper wire only, based on nameplate Minimum Circuit Ampacity (MCA).
4. Data shown for circuit one. The second circuit is always the same.
5. n/a - not available

Table 13. Electrical Data - 50Hz

Unit Size	Rated Power	Number Circuits	Qty Comp	Qty Fans	Fan Motor Power (kW)	Cond Fan FLA	Compressor RLA ^{1 2}	Compressor LRA ^{1 3}	MCA	MOPD
20	400/50/3	1	2	2	1	2.4	17-17	142-142	46	60
26	400/50/3	1	2	2	1	2.4	21-21	158-158	55	70
30	400/50/3	1	2	3	1	2.4	27-27	160-160	71	90
35	400/50/3	1	2	3	1	2.4	27-33	160-215	79	110
40	400/50/3	2	4	4	1	2.4	17-17/17-17	142-142/142-142	85	100
52	400/50/3	2	4	4	1	2.4	21-21/21-21	158-158/158-158	102	110
60	400/50/3	2	4	6	1	2.4	27-27/27-27	160-160/160-160	133	150
70	400/50/3	2	4	6	1	2.4	27-33/27-33	160-215/215-160	147	175
80	400/50/3	2	4	6	1	2.4	33-33/33-33	215-215/215-215	160	175
90	400/50/3	2	4	6	1	2.4	33-43/33-43	215-260/260-215	181	200
100	400/50/3	2	4	8	1	2.4	43-43/43-43	260-260/260-260	204	225
110	400/50/3	2	4	8	1	2.4	43-47/43-47	260-320/320-260	214	250
120	400/50/3	2	4	8	1	2.4	47-47/47-47	320-320/320-320	223	250

1. RLA - Rated Load Amps - Rated in accordance with UL Standard 1995.
2. LRA - Locked Rotor Amps - Based on full winding starts.
3. MCA - Minimum Circuit Ampacity - 125 percent of largest compressor RLA plus 100 percent of all other loads.
4. MOPD or Max fuse size - 225 percent of the largest compressor RLA plus all other loads.
5. Local codes may take precedence.
6. Voltage Utilization Range: +/- 10% of rated voltage
Rated voltage (use range): 400/50/3 (360-440)
7. One separate 120/50/1, 15 amp customer provided power connection is required to power the heaters.
8. n/a - not available
9. Pump package not available with 50 Hz units.

Table 14. Lug Size Range - 50 Hz

Unit Size	Rated Power	Terminal Blocks	Std Fault Ckt Breaker ¹	High Fault Ckt Breaker ¹
20	400/50/3	#6 - 350 MCM	#14 - 1/0	#14 - 1/0
26	400/50/3	#6 - 350 MCM	#14 - 1/0	#14 - 1/0
30	400/50/3	#6 - 350 MCM	#14 - 1/0	#14 - 1/0
35	400/50/3	#6 - 350 MCM	#14 - 1/0	#14 - 1/0
40	400/50/3	#4 - 500 MCM	#6 - 350 MCM	#6 - 350 MCM
52	400/50/3	#4 - 500 MCM	#6 - 350 MCM	#6 - 350 MCM
60	400/50/3	#4 - 500 MCM	#6 - 350 MCM	#6 - 350 MCM
70	400/50/3	#4 - 500 MCM	#6 - 350 MCM	#6 - 350 MCM
80	400/50/3	#4 - 500 MCM	#6 - 350 MCM	#6 - 350 MCM
90	400/50/3	#4 - 500 MCM	#6 - 350 MCM	#6 - 350 MCM
100	400/50/3	#4 - 500 MCM	3/0 - 500 MCM ²	3/0 - 500 MCM ²
110	400/50/3	#4 - 500 MCM	3/0 - 500 MCM ²	3/0 - 500 MCM ²
120	400/50/3	#4 - 500 MCM	3/0 - 500 MCM ²	3/0 - 500 MCM ²

1. Optional circuit breaker and high fault circuit breaker.
2. Will accept two conduits per phase in this size.
3. Copper wire only, based on nameplate Minimum Circuit Ampacity (MCA).
4. Data shown for circuit one. The second circuit is always the same.
5. n/a - not available

Electrical Connections

WARNING
HAZARDOUS VOLTAGE!
DISCONNECT ALL ELECTRIC POWER INCLUDING REMOTE DISCONNECTS AND FOLLOW LOCK OUT AND TAG PROCEDURES BEFORE SERVICING. INSURE THAT ALL MOTOR CAPACITORS HAVE DISCHARGED STORED VOLTAGE. UNITS WITH VARIABLE SPEED DRIVE, REFER TO DRIVE INSTRUCTIONS FOR CAPACITOR DISCHARGE.
FAILURE TO DO THE ABOVE COULD RESULT IN DEATH OR SERIOUS INJURY.

AVERTISSEMENT
TENSION DANGEREUSE!
COUPER TOUTES LES TENSIONS ET OUVRIER LES SECTIONNEURS A DISTANCE, PUIS SUIVRE LES PROCEDURES DE VERROUILLAGE ET DES ETIQUETTES AVANT TOUTE INTERVENTION. VERIFIER QUE TOUTS LES CONDENSATEURS DES MOTEURS SONT DECHARGES, DANS LE CAS D'UNITES COMPORTANT DES ENTRAINEMENTS A VITESSE VARIABLE, SE REPORTER AUX INSTRUCTIONS DE L'ENTRAINEMENT POUR DECHARGER LES CONDENSATEURS.
NE PAS RESPECTER CES MESURES DE PRECAUTION PEUT ENTRAENER DES BLESSURES GRAVES POUVANT ETRE MORTELLES.

ADVERTENCIA
¡VOLTAJE PELIGROSO!
DESCONECTE TODA LA ENERGIA ELECTRICA, INCLUIDO LAS DESCONEXIONES REMOTAS Y SIGA LOS PROCEDIMIENTOS DE CERRRE Y ETIQUETADO ANTES DE PROCEDER AL SERVICIO. ASEGURESE DE QUE TODOS LOS CAPACITORES DEL MOTOR HAYAN DESCARGADO EL VOLTAJE ALMACENADO. PARA LAS UNIDADES CON TRANSMISION DE VELOCIDAD VARIABLE, CONSULTE LAS INSTRUCCIONES PARA LA DESCARGA DEL CONDENSADOR.
EL NO REALIZAR LO ANTERIORMENTE INDICADO, PODRIA OCASIONAR LA MUERTE O SERIAS LESIONES PERSONALES.

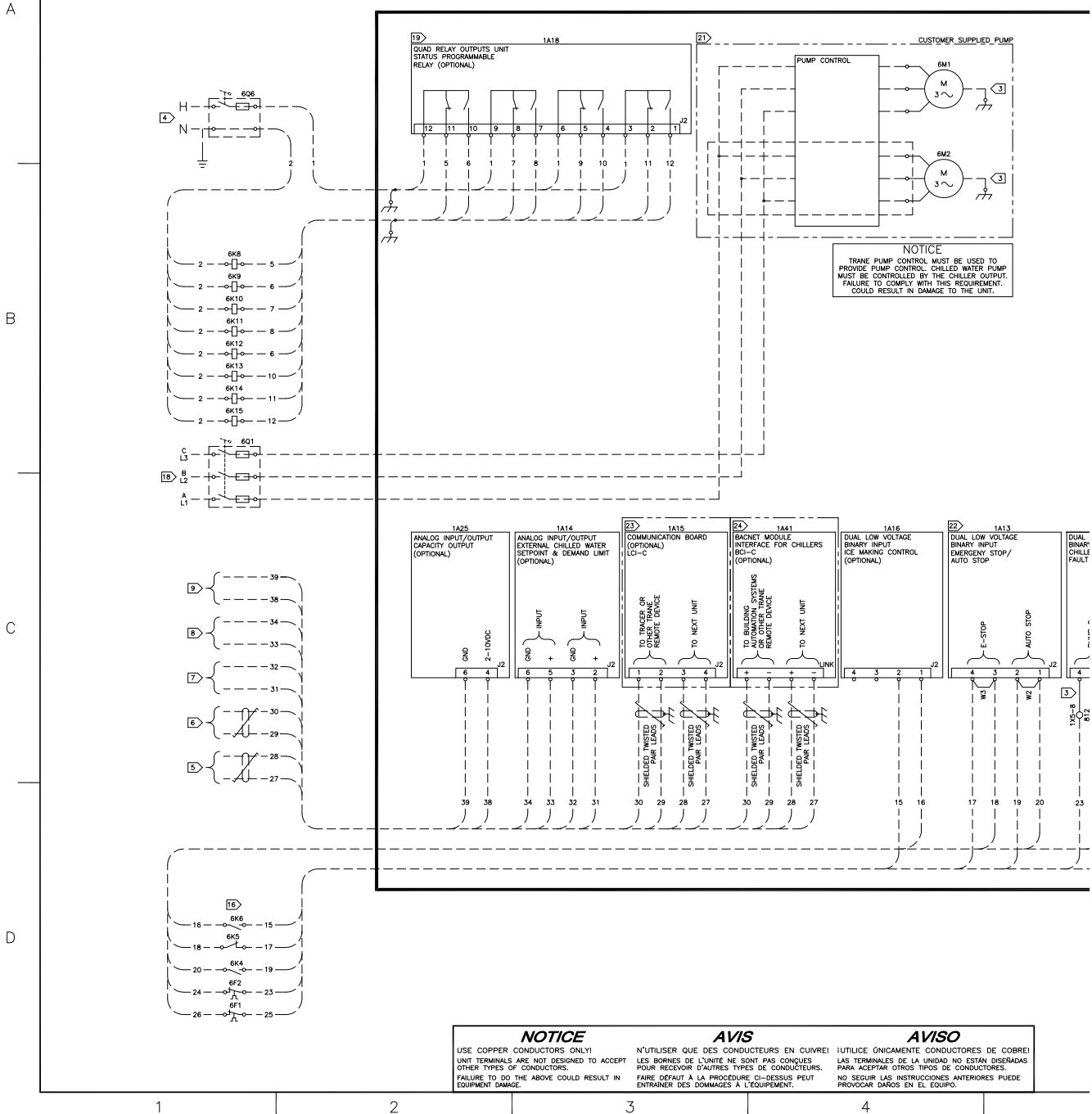

NOTICE
USE COPPER CONDUCTORS ONLY!
UNIT TERMINALS ARE NOT DESIGNED TO ACCEPT OTHER TYPES OF CONDUCTORS.
FAILURE TO DO THE ABOVE COULD RESULT IN EQUIPMENT DAMAGE.

AVIS
N'UTILISER QUE DES CONDUCTEURS EN CUIVRE!
LES BORNES DE L'UNITÉ NE SONT PAS CONÇUES POUR RECEVOIR D'AUTRES TYPES DE CONDUCTEURS.
FAIRE DÉFAUT À LA PROCÉDURE CI-DESSUS PEUT ENTRAÎNER DES DOMMAGES À L'ÉQUIPEMENT.

AVISO
UTILICE ÚNICAMENTE CONDUCTORES DE COBRE!
LAS TERMINALES DE LA UNIDAD NO ESTÁN DISEÑADAS PARA ACEPTAR OTROS TIPOS DE CONDUCTORES.
NO SEGUIR LAS INSTRUCCIONES ANTERIORES PUEDE PROVOCAR DAÑOS EN EL EQUIPO.



Electrical Connections

A	<p>1 SINGLE SOURCE POWER IS PROVIDED AS STANDARD ON THESE PRODUCTS, FIELD CONNECTIONS ARE MADE TO 1X1, OR 1Q2.</p> <p>2 FOR VOLTAGES 200V/60HZ, 220V/50HZ, 380V/60HZ, 460V/60HZ, WIRE 26A SHALL BE CONNECTED TO H2. FOR VOLTAGES 230V/60HZ & 575V/60HZ, WIRE 26A SHALL BE CONNECT TO H3. 400V/50HZ UNIT IS FACTORY WIRED WITH 26A CONNECTED TO H3 – RECONNECT WIRE 26A TO H2 FOR 380V/50HZ, OR H4 FOR 415V/50HZ. H4 IS ONLY AVAILABLE WITH 400V/50HZ PANELS.</p> <p>3 FIELD CONNECTIONS ARE ONLY MADE IN A CUSTOMER PROVIDED PUMP (PTYP=NONE). THESE CONNECTIONS WILL BE MADE BY THE FACTORY WHEN THE PUMP IS PROVIDED BY THE FACTORY (PTYP=DHHP).</p> <p>4 CUSTOMER SUPPLIED POWER 115/60/1 OR 220/50/1 TO POWER RELAYS. MAX. FUSE SIZE IS 20 AMPS. GROUND ALL CUSTOMER SUPPLIED POWER SUPPLIES AS REQUIRED BY APPLICABLE CODES. GREEN GROUND SCREWS ARE PROVIDED IN UNIT CONTROL PANEL.</p> <p>5 WIRED TO NEXT UNIT. 22 AWG SHIELDED COMMUNICATION WIRE EQUIVALENT TO HELIX LF22P0014216 RECOMMENDED. THE SUM TOTAL OF ALL INTERCONNECTED CABLE SEGMENTS NOT TO EXCEED 4500 FEET. CONNECTION TOPOLOGY SHOULD BE DAISY CHAIN. REFER TO BUILDING AUTOMATION SYSTEM (BAS) COMMUNICATION INSTALLATION LITERATURE FOR END OF LINE TERMINATION RESISTOR REQUIREMENTS.</p> <p>6 WIRED TO TRACER OR OTHER TRANE REMOTE DEVICE. 22 AWG SHIELDED COMMUNICATION WIRE EQUIVALENT TO HELIX LF22P0014216 RECOMMENDED. THE SUM TOTAL OF ALL INTERCONNECTED CABLE SEGMENTS NOT TO EXCEED 4500 FEET. CONNECTION TOPOLOGY SHOULD BE DAISY CHAIN. REFER TO BUILDING AUTOMATION SYSTEM (BAS) COMMUNICATION INSTALLATION LITERATURE FOR END OF LINE TERMINATION RESISTOR REQUIREMENTS.</p>
B	<p>7 WIRED TO CUSTOMER CHILLED WATER SET POINT 2–10V OR 4–20mA.</p> <p>8 WIRED TO CUSTOMER EXTERNAL DEMAND LIMIT 2–10V OR 4–20mA.</p> <p>9 WIRED TO CUSTOMER 2–10V OR 4–20mA % CAPACITY ANNUNCIATOR.</p> <p>11. REFER TO CGAM ELECTRICAL SCHEMATIC FOR SPECIFIC ELECTRICAL CONNECTION INFORMATION AND NOTES PERTAINING TO WIRING INSTALLATION.</p> <p>12 ALL UNIT POWER WIRING MUST BE 600 VOLT COPPER CONDUCTORS ONLY AND HAVE A MINIMUM TEMPERATURE INSULATION RATING OF 90 DEGREE C. REFER TO UNIT NAMEPLATE FOR MINIMUM CIRCUIT AMPACITY AND MAXIMUM OVERCURRENT PROTECTION DEVICE. PROVIDE AN EQUIPMENT GROUND IN ACCORDANCE WITH APPLICABLE ELECTRIC CODES. REFER TO WIRE RANGE TABLE FOR LUG SIZES.</p> <p>13. ALL FIELD WIRING MUST BE IN ACCORDANCE WITH NATIONAL ELECTRIC CODE AND LOCAL REQUIREMENTS.</p> <p>14. ALL CUSTOMER CONTROL CIRCUIT WIRING MUST BE COPPER CONDUCTORS ONLY AND HAVE A MINIMUM INSULATION RATING OF 300 VOLTS. EXCEPT AS NOTED, ALL CUSTOMER WIRING CONNECTIONS ARE MADE TO CIRCUIT BOARD MOUNTED BOX LUGS WITH A WIRE RANGE OF 14 TO 18 AWG OR DIN RAIL MOUNTED SPRING FORCE TERMINALS.</p>
C	<p>15 UNIT PROVIDED DRY CONTACTS FOR THE CONDENSER/CHILLED WATER PUMP CONTROL. RELAYS ARE RATED FOR 7.2 AMPS RESISTIVE, 2.88 AMPS PILOT DUTY, OR ½ HP, 7.2 FLA AT 120 VOLTS 60 HZ, CONTACTS ARE RATED FOR 5 AMPS GENERAL PURPOSE DUTY 240 VOLTS.</p> <p>16 CUSTOMER SUPPLIED CONTACTS FOR ALL LOW VOLTAGE CONNECTIONS MUST BE COMPATIBLE WITH DRY CIRCUIT 24 VOLTS DC FOR A 12 mA RESISTIVE LOAD. SILVER OR GOLD PLATED CONTACTS RECOMMENDED.</p> <p>17 FIELD CONNECTIONS ARE ONLY MADE IN A CUSTOMER PROVIDED PUMP. THESE CONNECTIONS WILL BE MADE BY THE FACTORY WHEN THE PUMP IS PROVIDED BY THE FACTORY. CUSTOMER SUPPLIED POWER 115V, 60Hz, 1PH.</p> <p>18 CUSTOMER SUPPLIED 3 PHASE POWER.</p> <p>19 OPTIONAL FIELD ASSIGNED PROGRAMMABLE RELAYS (STAT=PRLY). CLASS 1 FIELD WIRED MODULE, RELAY AT 120V: 7.2A RESISTIVE 2.88A PILOT DUTY, 1/2HP 7.2FLA; AT 240VAC: 5 AMPS GENERAL PURPOSE.</p> <p>20 WIRED TO CUSTOMER 0–10 VDC PUMP SPEED SIGNAL.</p>
D	<p>21 WHEN FACTORY PROVIDED PUMP IS NOT SELECTED. CUSTOMER MUST SUPPLY SUITABLE PUMP SYSTEM. REFER TO PUMP MANUFACTURER FOR WIRING REQUIREMENTS.</p> <p>22 THE CONTACTS FOR AUTO STOP AND EMERGENCY STOP SWITCHES ARE JUMPERED AT THE FACTORY BY JUMPERS W2 & W3 TO ENABLE UNIT OPERATION. IF REMOTE CONTROL IS DESIRED, REMOVED THE JUMPERS AND CONNECT TO THE DESIRED CONTROL CIRCUIT.</p> <p>23 1A15, LCI MODULE USED WHEN (COMM = LCI).</p> <p>24 1A41, BACNET INTERFACE MODULE USED WHEN (COMM = BCNT).</p>
	<p>1</p> <p>2</p> <p>3</p> <p>4</p>

TRANE <small>THIS DRAWING IS PROPRIETARY AND SHALL NOT BE COPIED OR ITS CONTENTS DISCLOSED TO OUTSIDE PARTIES WITHOUT THE WRITTEN CONSENT OF TRANE</small> DRAWN BY: _____ ©TRANE DATE: 12/5/08 REPLACES: _____ REVISION DATE: _____ SIMILIAR TO: _____	2309-2076 SHEET 2 OF 2 REV D
FIELD WIRING DIAGRAM CGAM (NAR) SLANT, V & W UNITS	

REPLACEMENT FUSE TABLE					
FUSE	VOLTAGE	Hz	CLASS	AMPS	NOTES
1F1	ALL	ALL	CC	10	FUSE, COMPRESSOR CRANKCASE HEATER, CIRCUIT 1
1F2	ALL	ALL	CC	10	
1F3	ALL	ALL	CC	10	
1F4	ALL	ALL	CC	10	FUSE, COMPRESSOR CRANKCASE HEATER, CIRCUIT 2
1F5, 1F6	200	60	CC	10	FUSE, CONTROL POWER TRANSFORMER, PRIMARY
	230	60	CC	8	
	380	60	CC	5	
	400	50	CC	5	
	460	60	CC	5	
1F7	575	60	CC	4	THIRD PHASE, PHASE PROTECTION MONITOR
	200	60	CC	10	
	230	60	CC	8	
	380	60	CC	5	
	400	50	CC	5	
1F8, 1F9, 1F10	460	60	CC	5	DUAL POINT, POWER SECOND PHASE, PHASE PROTECTION MONITOR
	575	60	CC	4	
	200	60	CC	10	
	230	60	CC	8	
	380	60	CC	5	
1F11	ALL	ALL	CC	10	FUSE, CONTROL POWER TRANSFORMER, SECONDARY, 115V
1F12 - 1F13	ALL	ALL	CC	6	FUSE, CONTROL POWER TRANSFORMER, SECONDARY, 24V
1F14 - 1F16 1F17 - 1F19	200-460	ALL	CC	30	FUSE, INVERTER, FAN (FAST ACTING EXCEPT 575V)
	575	60	CC	6	
1F38 - 1F40 1F44 - 1F46	ALL	ALL	CC	30	FAST ACTING FUSE, ATM-R-30
1F38 - 1F40 1F41 - 1F43	ALL	ALL	CC	30	FAST ACTING FUSE, USED ONLY ON W UNITS
FACTORY PROVIDED PUMP INVERTER FUSE					
1F32, 1F33, 1F34	200,230	60	CC	30	3.7Kw VSD
	460,575	60	CC	25	5.5 Kw VSD
	200,230	60	J	60	7.5Kw VSD
			CC	30	
	200,230	60	J	60	11Kw VSD
				40	

Dimensions

Figure 4. CGAM 20 and 26 ton

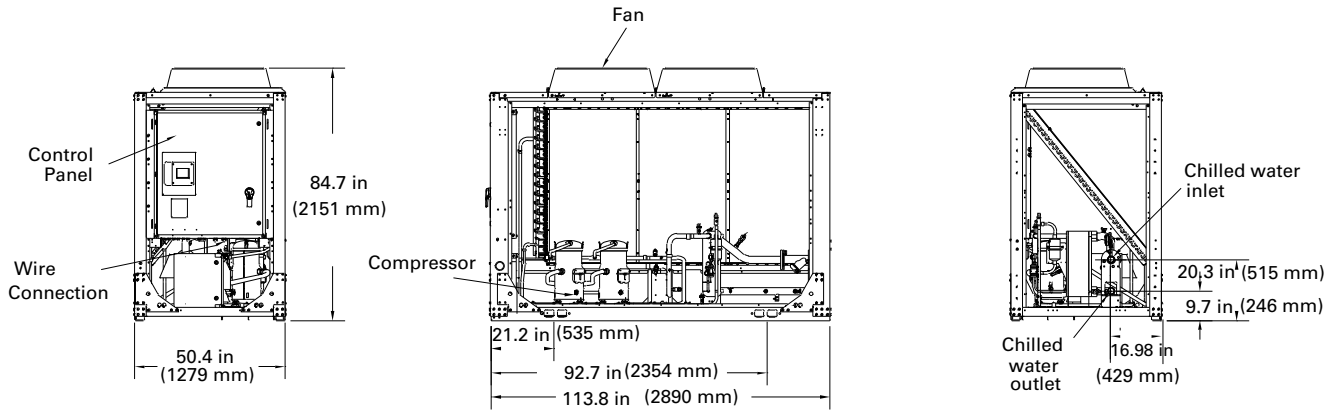

The number of fans shown does not represent the number of fans installed.

Water connections are 1.7 in (44 mm) from the end.

Figure 5. CGAM 20 and 26 ton - service clearances and mounting locations

Service Clearance

The number of fans shown does not represent the number of fans installed.

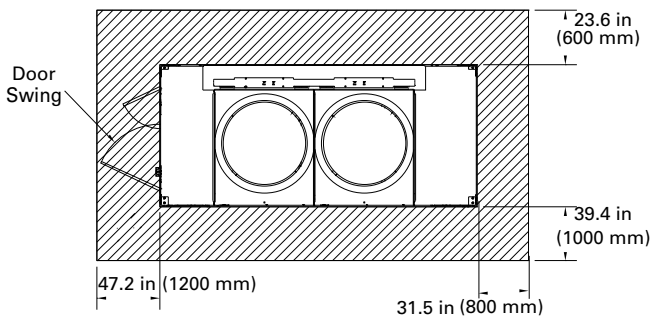

More clearance may be needed for airflow depending on the installation.

Mounting Locations

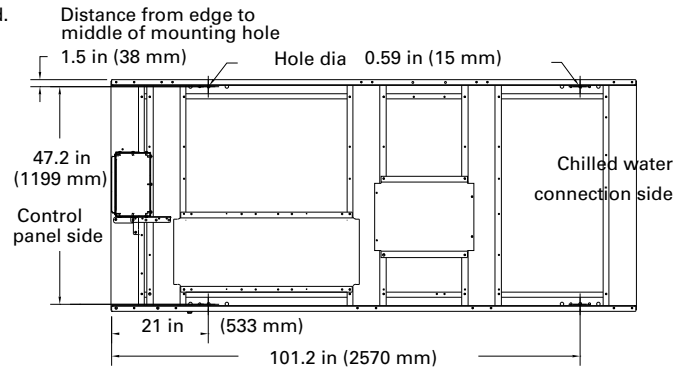

Total of four mounting locations.

Figure 6. CGAM 30 and 35 ton

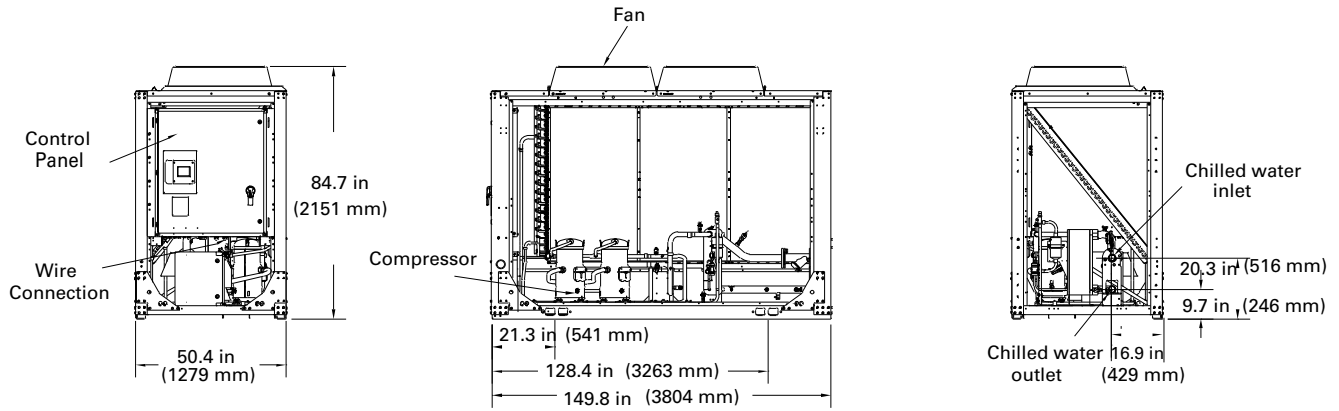

The number of fans shown does not represent the number of fans installed.

Water connections are 1.6 in (40 mm) from unit end.

Figure 7. CGAM 30 and 35 ton - service clearances and mounting locations

Service Clearance

The number of fans shown does not represent the number of fans installed.

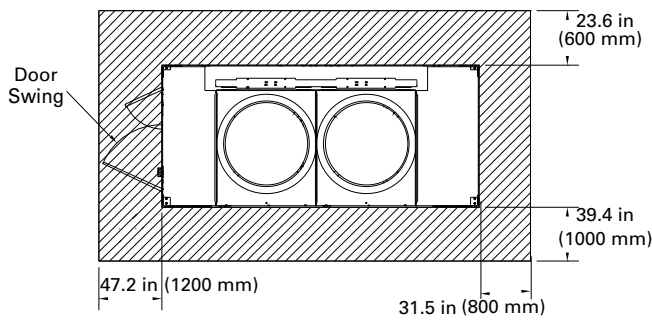

More clearance may be needed for airflow depending on the installation.

Mounting Locations

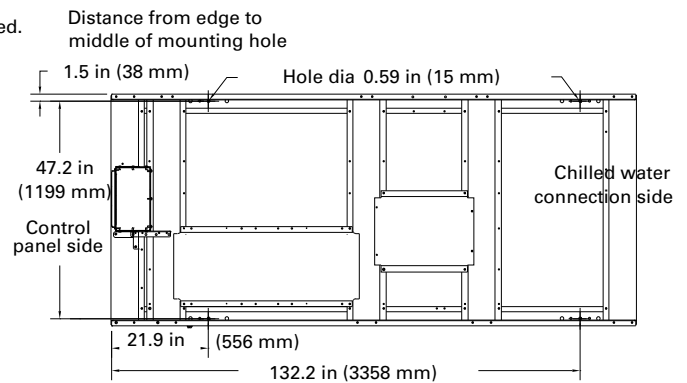

Total of four mounting locations.

Dimensions

Figure 8. CGAM 40 and 52 ton

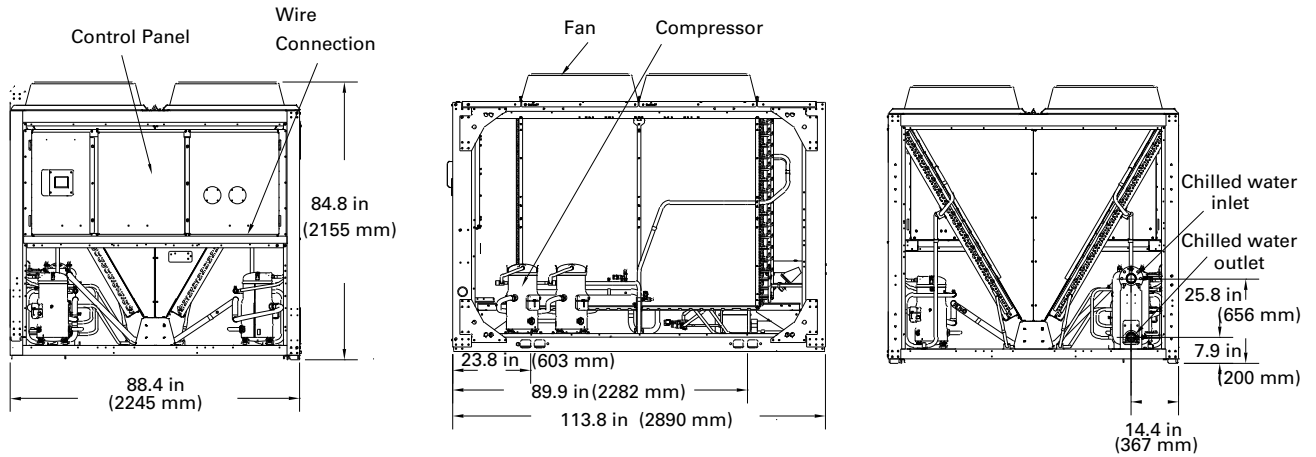

The number of fans shown does not represent the number of fans installed.

Water connections are even with unit end.

Figure 9. CGAM 40 and 52 ton- service clearances and mounting locations

Service Clearance

The number of fans shown does not represent the number of fans installed.

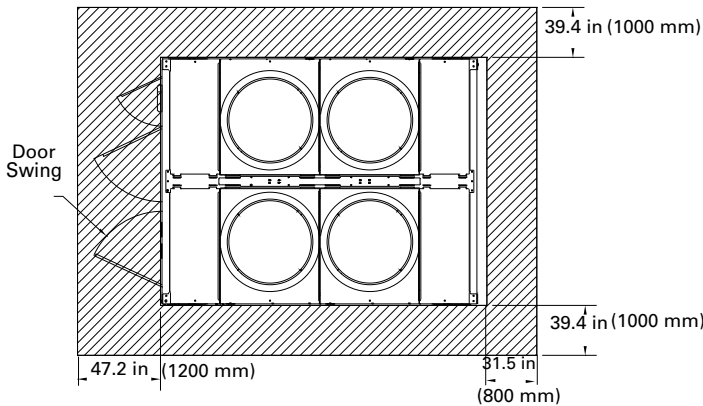

More clearance may be needed for airflow depending on the installation.

Mounting Locations

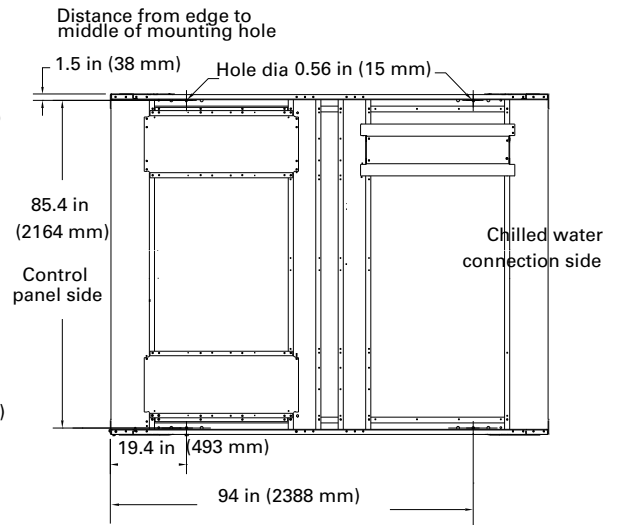

Total of four mounting locations.

Figure 10. CGAM 60 and 70 ton

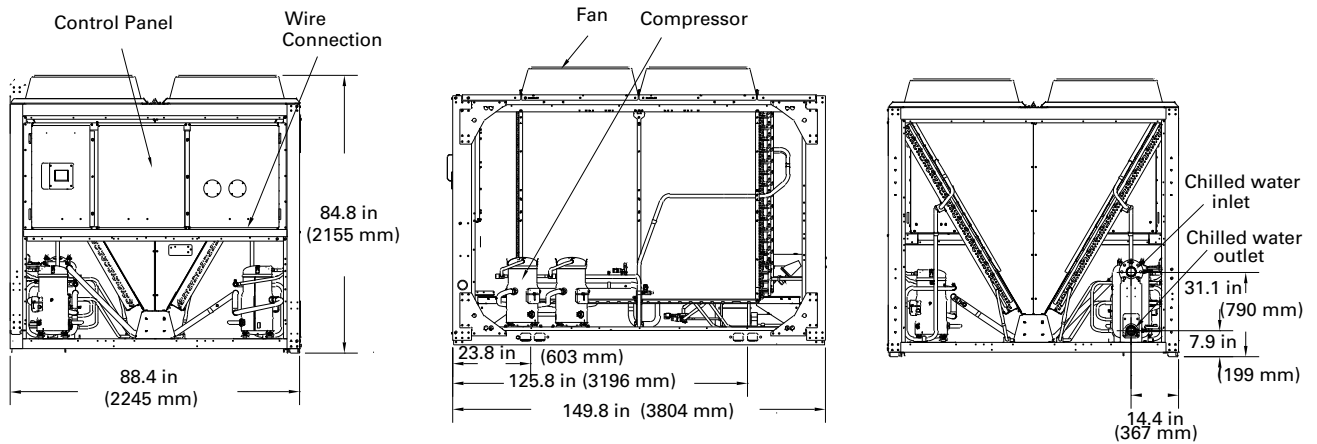

The number of fans shown does not represent the number of fans installed.

Water connections are even with unit end.

Figure 11. CGAM 60 and 70 ton - service clearances and mounting locations

Service Clearance

The number of fans shown does not represent the number of fans installed.

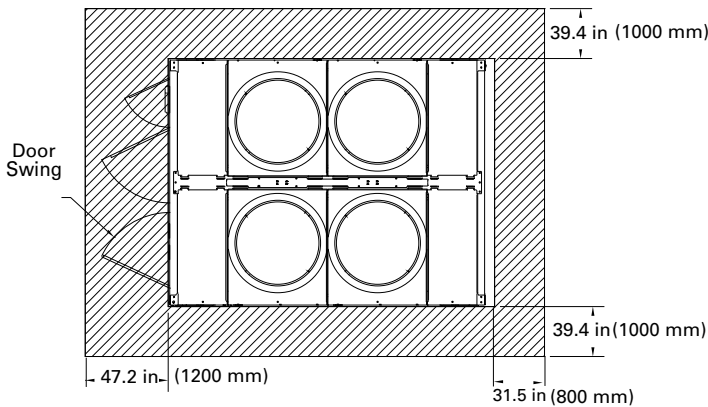

More clearance may be needed for airflow depending on the installation.

Mounting Locations

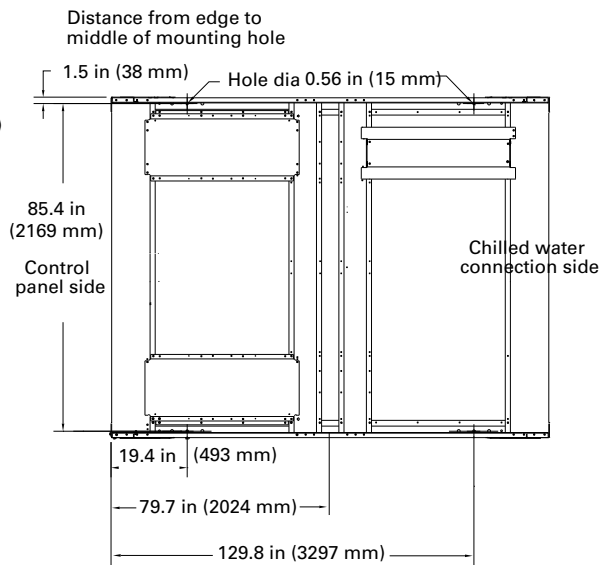

Total of six mounting locations.

Dimensions

Figure 12. CGAM 80 and 90 ton

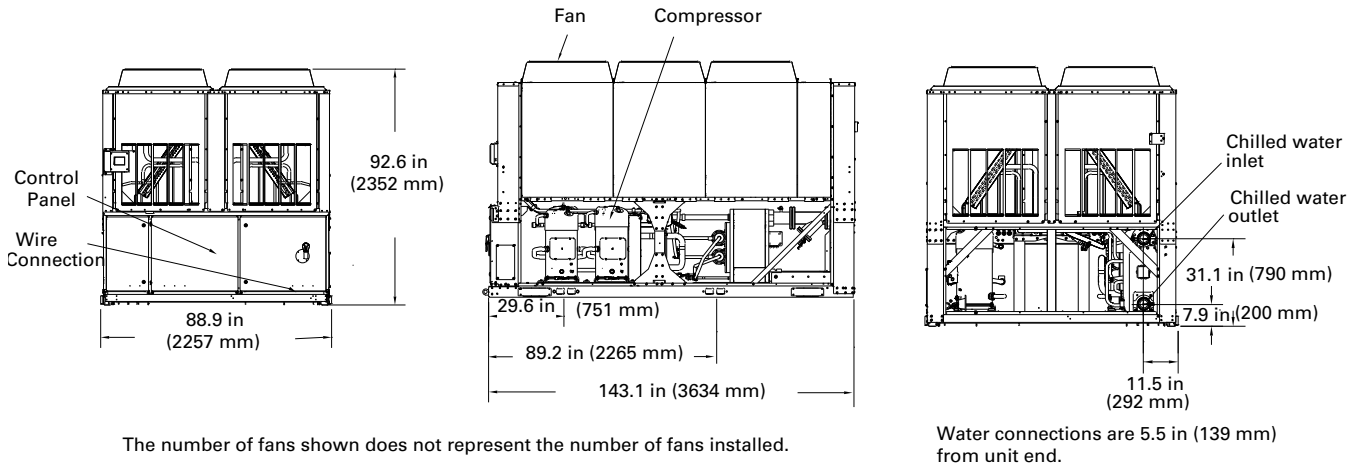
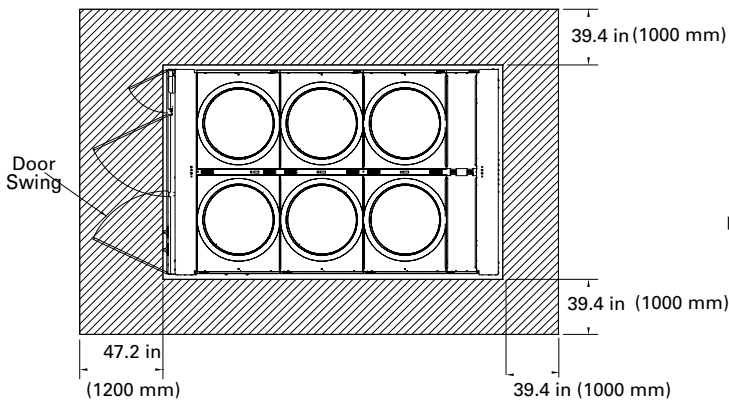

Figure 13. CGAM 80 and 90 ton - service clearances and mounting locations

Service Clearance

The number of fans shown does not represent the number of fans installed.



More clearance may be need for airflow depending on the installation.

Mounting Locations

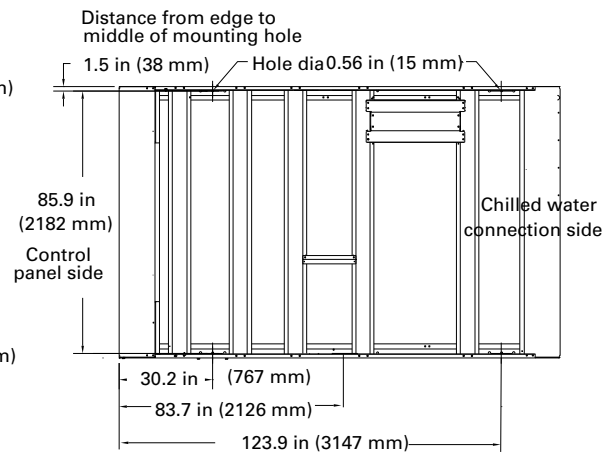

Total of six mounting location.

Figure 14. CGAM 100, 110 and 120 ton

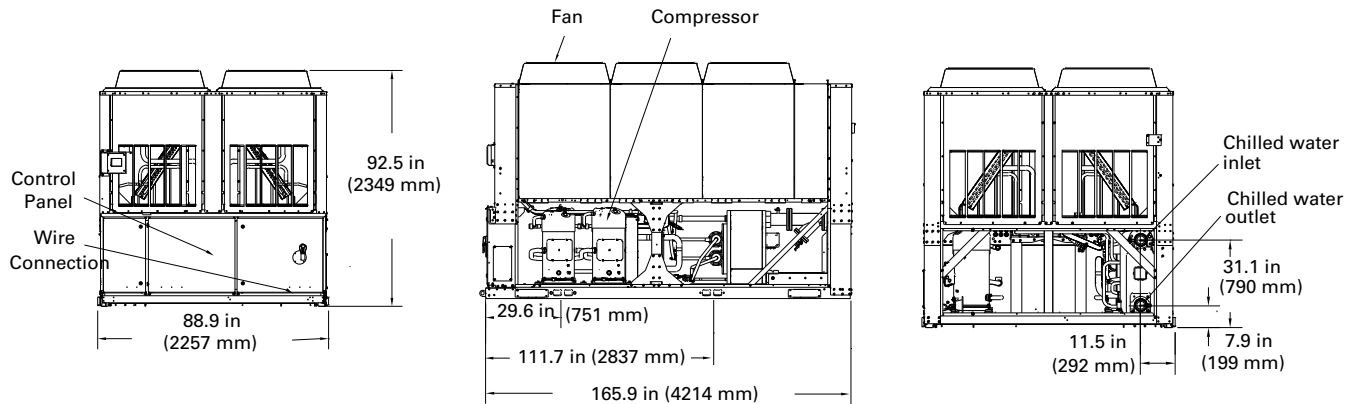

The number of fans shown does not represent the number of fans installed.

Water connections are 5.4 in (139 mm) from unit end.

Figure 15. CGAM 100, 110 and 120 ton- service clearances and mounting locations

Service Clearance

The number of fans shown does not represent the number of fans installed.

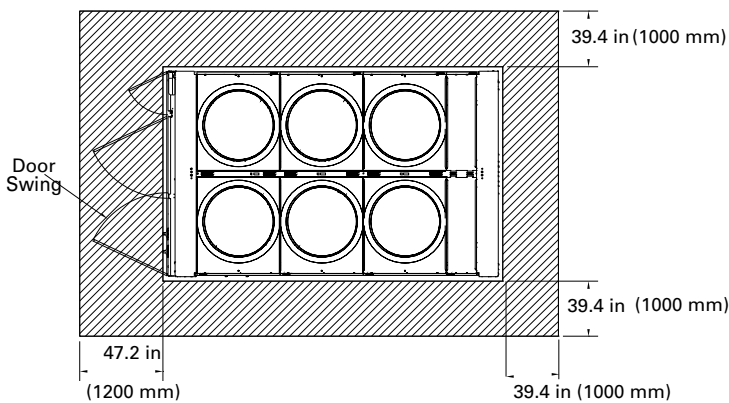

More clearance may be needed for airflow depending on the installation.

Mounting Locations

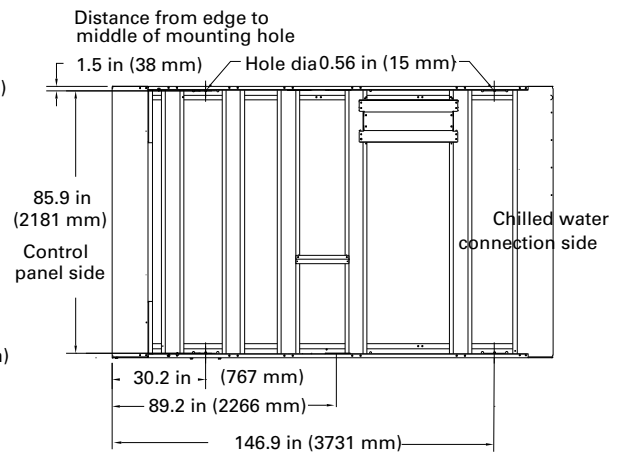

Total of six mounting locations.

Dimensions

Figure 16. CGAM 130 ton

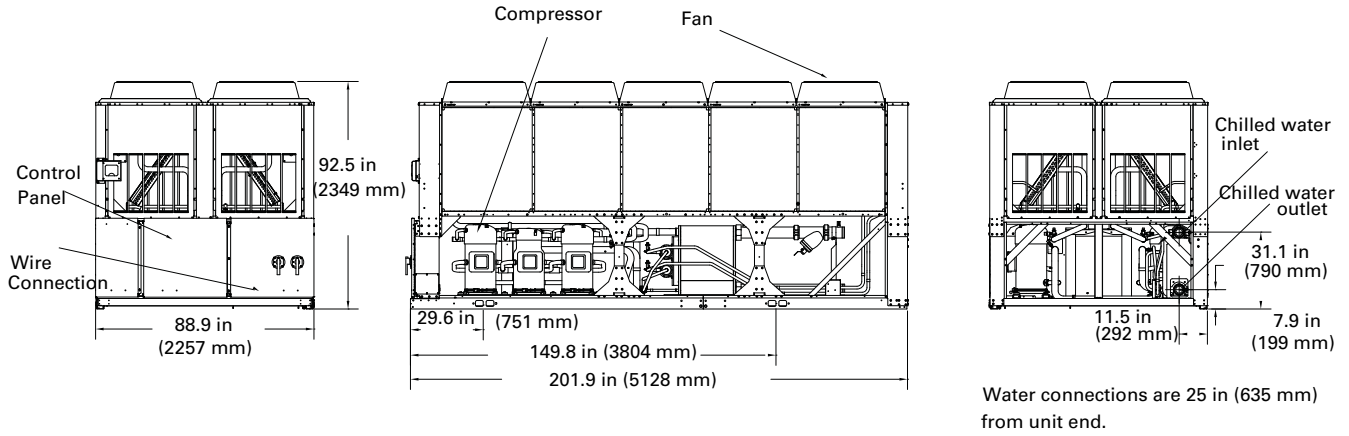

Figure 17. CGAM 130 ton- service clearances and mounting locations

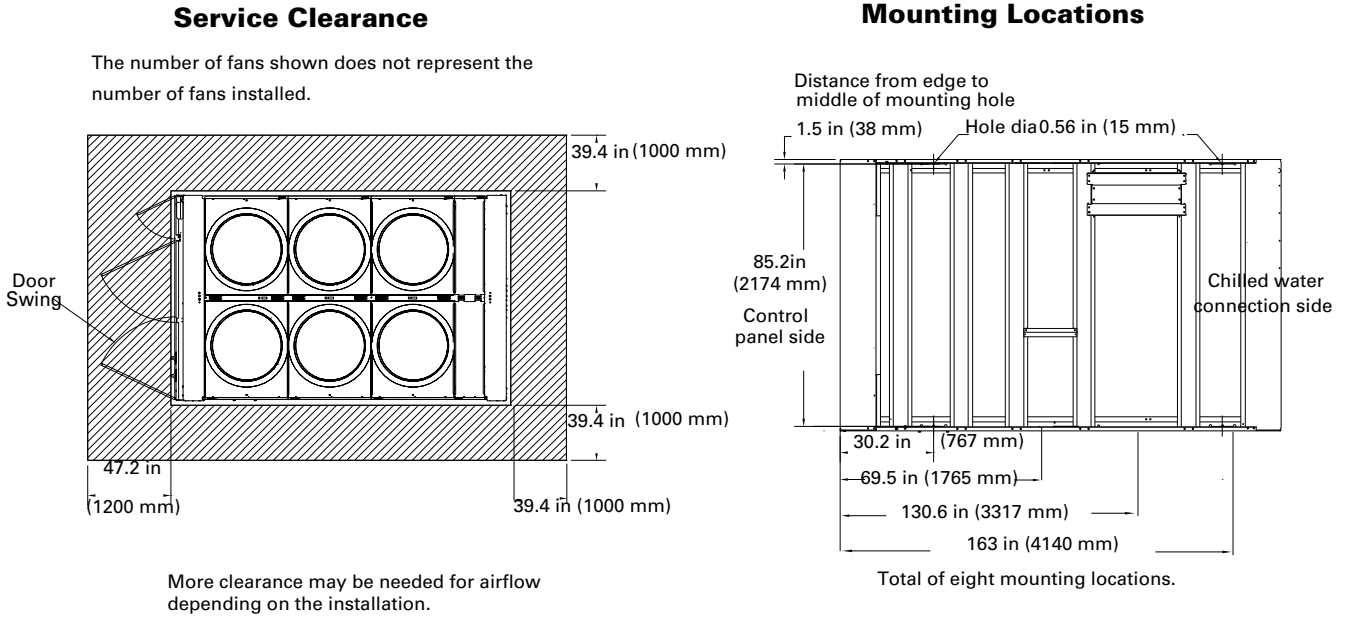
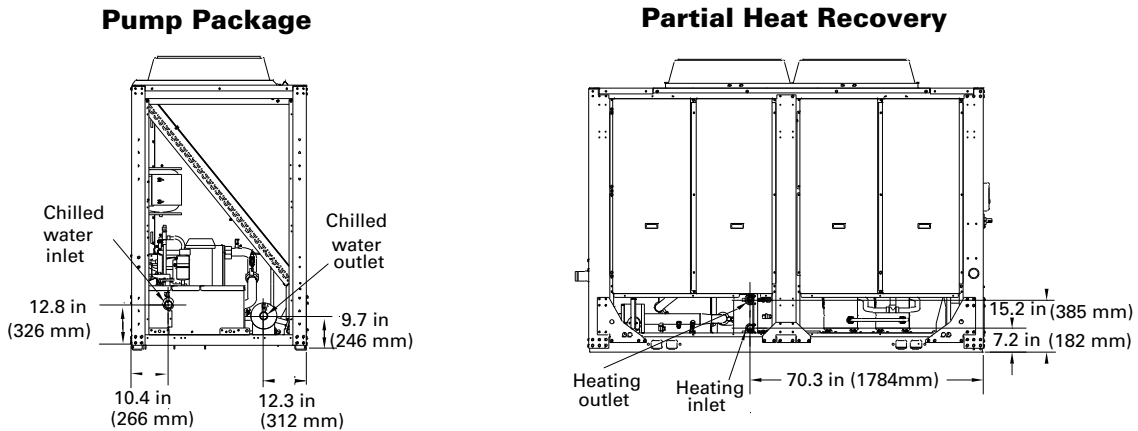

Figure 18. CGAM 20 and 26 ton - pump package, partial heat recovery unit water connections



Water connections are 1.3 in (33 mm) from unit end.

Partial heat recovery connections are even with unit edge.

The chilled water inlet and outlet connections are the same as the standard unit unless pump package is ordered.

Figure 19. CGAM 30 and 35 ton - pump package, partial heat recovery unit water connections

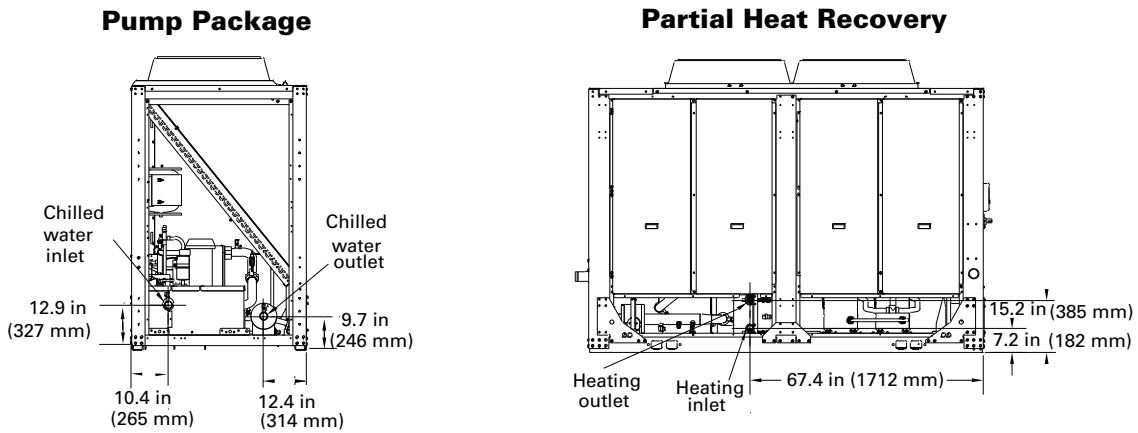

Water connections are 1.3 in (33mm) from unit end.

Partial heat recovery connections are even with unit edge.

The chilled water inlet and outlet connections are the same as the standard unit unless pump package is ordered.

Figure 20. CGAM 40 and 52 ton- pump package, partial heat recovery unit water connections

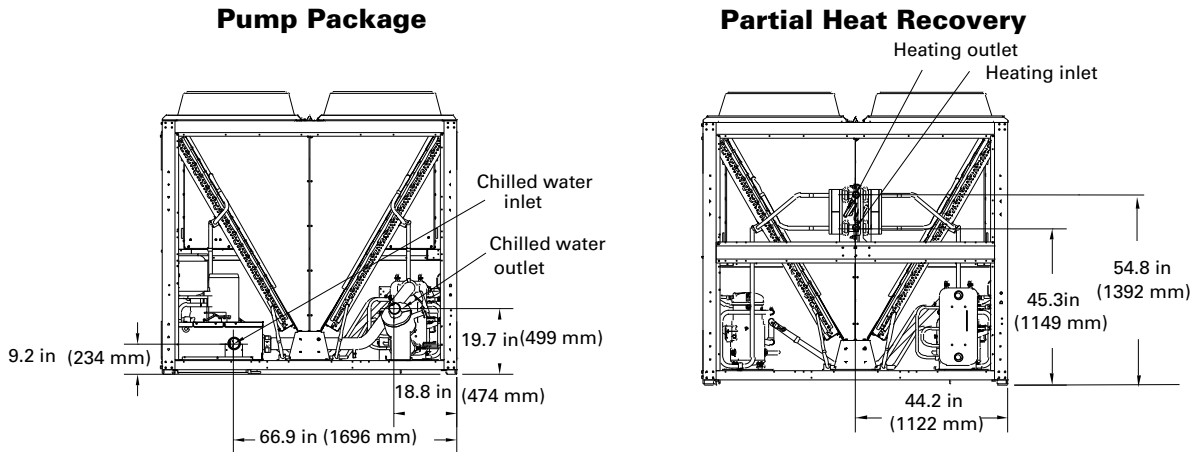

Water outlet connection is even with unit end, inlet is 6.1 in (154 mm) from unit end.

Partial heat recovery connections are even with unit end. The chilled water connections are the same as the standard unit unless pump package is ordered.

Figure 21. CGAM60 and 70 ton- pump package, partial heat recovery unit water connections

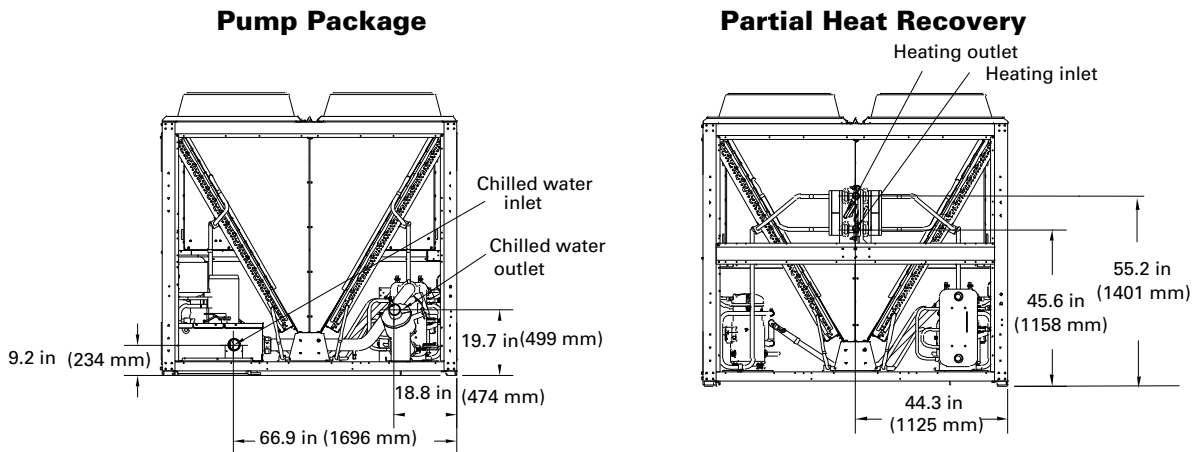

Water outlet connection is even with unit end, inlet is 6.1 in (154 mm) from unit end.

Partial heat recovery connections are even with unit end. The chilled water connections are the same as the standard unit unless pump package is ordered.

Figure 22. CGAM 80-120 ton- pump package, partial heat recovery unit water connections

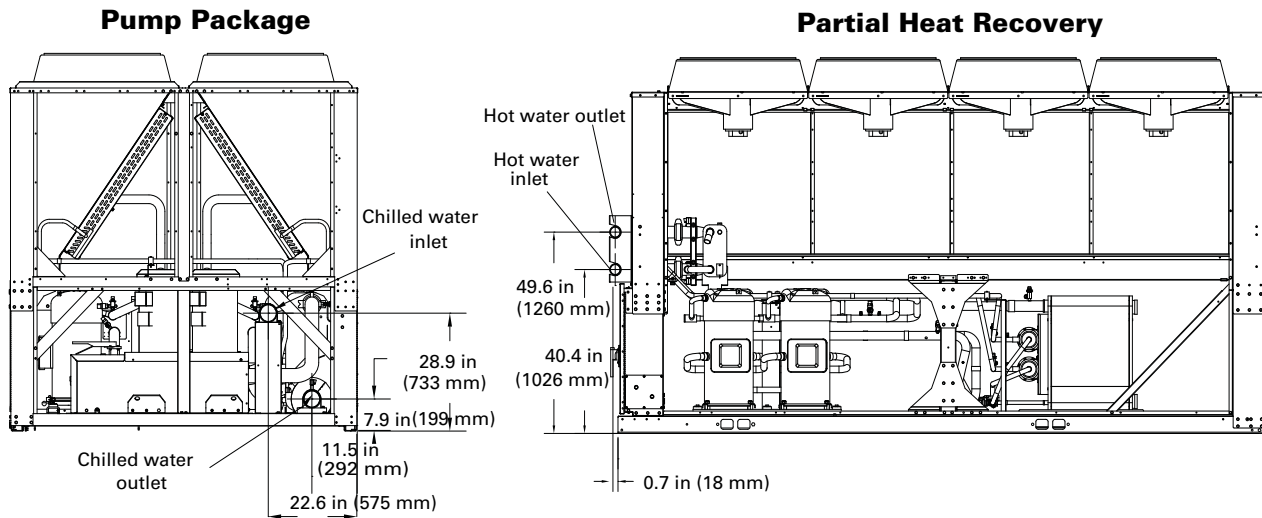

Water connections are 5.9 in (151 mm) from unit end.

Water connections are 1.1 in (28 mm) from unit side.

Figure 23. CGAM 130 ton- pump package, partial heat recovery unit water connections

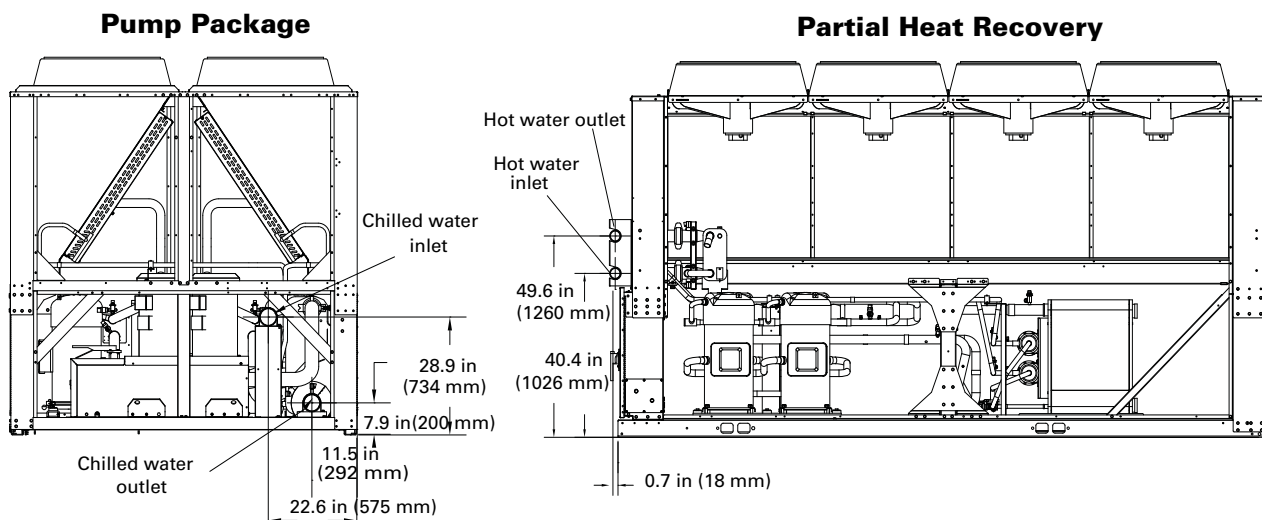

Water outlet connection is 25 in (635 mm) and inlet is 6.3 in (159 mm) from unit end.

Water connections are 1.1" (28 mm) from unit side.

Weights

Weights

Table 15. Weights - 60 Hz

Tons	Without Pump				With Pump				Partial Heat Recovery - add				Copper - add	
	Shipping		Operating		Shipping		Operating		Shipping		Operating		Additional	
	lbs	kg	lbs	kg	lbs	kg	lbs	kg	lbs	kg	lbs	kg	lbs	kg
20	2185	991	2207	1002	2726	1236	2814	1277	39	18	24	11	258	117
26	2249	1020	2278	1034	2790	1265	2891	1311	39	8	31	14	258	117
30	2846	1291	2879	1306	3388	1537	3496	1586	47	21	36	16	360	163
35	2878	1305	2919	1325	3420	1551	3545	1608	47	21	44	20	360	163
40	3666	1663	3696	1677	4285	1944	4382	1988	94	43	34	15	515	234
52	3761	1706	3805	1726	4379	1986	4505	2044	94	43	49	22	515	234
60	4978	2258	5032	2283	5814	2637	5984	2715	111	50	59	27	719	326
70	5045	2289	5119	2323	5881	2668	6092	2764	111	50	80	36	719	326
80	5607	2543	5691	2582	6486	2942	6788	3080	170	77	90	41	1270	576
90	5859	2658	5959	2704	6738	3056	7073	3209	170	77	109	49	1270	576
100	6646	3015	6757	3066	7549	3424	7907	3587	178	81	120	54	1511	686
110	6724	3050	6844	3105	7627	3460	8003	3631	178	81	129	59	1511	686
120	6762	3067	6882	3122	8018	3637	8393	3808	178	81	131	60	1511	686
130	7753	3517	7898	3583	9006	4085	9427	4277	178	81	156	71	1889	857

1. Weights based on aluminum fins, refrigerant charge, isolators, circuit breaker and louvers.

2. Base unit weights are shown above on the left side for units without a pump package and units with a pump package. The partial heat recovery and copper weights are in addition to the base unit weights.

Table 16. Weights - 50 Hz

Tons	Base Unit				Partial Heat Recovery - add				Copper	
	Shipping Weight		Operating Weight		Shipping Weight		Operating Weight		Additional	
	lbs	kg	lbs	kg	lbs	kg	lbs	kg	lbs	kg
20	2187	992	2209	1002	39	18	24	11	258	117
26	2249	1020	2278	1034	39	18	31	14	258	117
30	2845	1291	2879	1306	47	21	36	16	360	163
35	2877	1305	2919	1325	47	21	44	20	360	163
40	3665	1663	3696	1677	94	43	34	15	515	234
52	3760	1706	3805	1726	94	43	48	22	515	234
60	4977	2258	5032	2283	111	50	59	27	719	326
70	5044	2289	5119	2323	111	50	79	36	719	326
80	5606	2543	5691	2582	170	77	90	41	1270	576
90	5857	2657	5958	2703	170	77	107	49	1270	576
100	6628	3007	6741	3059	178	81	118	54	1511	686
110	6711	3045	6833	3100	178	81	129	59	1511	686
120	6756	3065	6878	3121	178	81	129	59	1511	686

1. Weights based on aluminum fins, refrigerant charge, isolators, circuit breaker and louvers.

2. The partial heat recovery and copper weights are in addition to the base unit weights.

Mechanical Specifications

General

Units are constructed of galvanized steel frame with galvanized steel panels and access doors. Component surfaces are finished with a powder-coated paint. Each unit ships with full operating charges of refrigerant and oil.

Compressor and Motor

The unit is equipped with two or more hermetic, direct-drive, 3600 rpm 60 Hz (3000 rpm 50 Hz) suction gas-cooled scroll compressors. The simple design has only three major moving parts and a completely enclosed compression chamber which leads to increased efficiency. Overload protection is included. The compressor includes: centrifugal oil pump, oil level sight glass and oil charging valve. Each compressor will have compressor heaters installed and properly sized to minimize the amount of liquid refrigerant present in the oil sump during off cycles.

Unit-Mounted Starter

The control panel is designed per UL 1995. The starter is an across-the-line configuration, factory-mounted and fully pre-wired to the compressor motor and control panel. A factory-installed, factory-wired 820 VA control power transformer provides all unit control power (120 Vac secondary) and Trane CH530 module power (24 Vac secondary). Power line connection type is standard with a terminal block.

Evaporator

Braze plate heat exchanger is made of stainless steel with copper as the braze material. It is designed to withstand a refrigerant side working pressure of 430 psig (29.6 bars) and a waterside working pressure of 150 psig (10.5 bars). Evaporator is tested at 1.1 times maximum allowable refrigerant side working pressure and 1.5 times maximum allowable water side working pressure. It has one water pass. Immersion heaters protect the evaporator to an ambient of -20°F (-29°C).

The evaporator is covered with factory-installed 0.75 inch (19.05 mm) Armaflex II or equal (k=0.28) insulation. Foam insulation is used on the suction line. Water pipe extensions with insulation go from the evaporator to the edge of the unit.

Condenser

Air-cooled condenser coils have aluminum fins mechanically bonded to internally-finned copper tubing. The condenser coil has an integral subcooling circuit. The maximum allowable working pressure of the condenser is 650 psig (44.8 bars). Condensers are factory proof and leak tested at 715 psig (49.3 bars).

Direct-drive vertical discharge condenser fans are balanced. Three-phase condenser fan motors with permanently lubricated ball bearings and external thermal overload protection are provided.

Units start and operate from 0°F to 125°F (-18°C to 52°C) for wide ambient. Wide ambient allows operation down to 0°F which is accomplished by a variable speed fan on each circuit that modulates to maintain system differential pressure.

Refrigerant Circuit and Capacity Modulation

The 20-35 ton units have single refrigerant circuits. The 40-130 ton units have dual refrigerant circuits. Each refrigerant circuit has Trane scroll compressors piped in parallel with a passive oil management system. A passive oil management system maintains proper oil levels within compressors and has no moving parts. Each refrigerant circuit includes filter drier, electronic expansion valve, and liquid line and discharge service valves.

Capacity modulation is achieved by turning compressors on and off. The 20-35 ton units have two capacity stages. The 40-120 ton units have four capacity stages. The 130 ton unit has six capacity stages.



Mechanical Specifications

Unit Controls (Trane CH530)

The microprocessor-based control panel is factory-installed and factory-tested. The control system is powered by a pre-wired control power transformer, and will turn on and off compressors to meet the load. Microprocessor-based chilled water reset based on return water is standard.

The Trane CH530 microprocessor automatically acts to prevent unit shutdown due to abnormal operating conditions associated with low evaporator refrigerant temperature and high condensing temperature. If an abnormal operating condition continues and the protective limit is reached, the machine will shut down.

The panel includes machine protection for the following conditions:

- Low evaporator refrigerant temperature and pressure
- High condenser refrigerant pressure
- Critical sensor or detection circuit faults
- High compressor discharge temperature (with low temp evaporator)
- Lost communication between modules
- Electrical distribution faults: phase loss, phase reversal or over temperature protection
- External and local emergency stop
- Loss of evaporator water flow

When a fault is detected, the control system conducts more than 100 diagnostic checks and displays results. The display will identify the fault, indicate date, time, and operating mode at time of occurrence, and provide type of reset required and a help message.

Clear Language Display Panel

Factory-mounted to the control panel door, the operator interface has an LCD touch-screen display for operator input and information output. This interface provides access to the following information: evaporator report, condenser report, compressor report, ASHRAE Guideline 3 report, operator settings, service settings, service tests, and diagnostics. All diagnostics and messages are displayed in "clear language."

Data contained in available reports includes:

- Water and air temperatures
- Refrigerant pressures and temperatures
- Flow switch status
- EXV position
- Compressor starts and run-time

All necessary settings and setpoints are programmed into the microprocessor-based controller via the operator interface. The controller is capable of receiving signals simultaneously from a variety of control sources, in any combination, and priority order of control sources can be programmed. The control source with priority determines active setpoints via the signal it sends to the control panel. Control sources may be:

- Local operator interface (standard)
- Hard-wired 4-20 mA or 2-10 Vdc signal from an external source (interface optional; control source not supplied)
- Time of day scheduling (optional capability available from local operator interface)
- LonTalk LCI-C (interface optional; control source not supplied)
- BACNet (interface optional; control source not supplied)
- Trane Tracer Summit system (interface optional; control source not supplied)

Quality Assurance

The quality management system applied by Trane has been subject to independent third-party assessment and approval to ISO 9001-2008. The products described in this catalog are designed, manufactured and tested in accordance with the approved system requirements described in the Trane Quality Manual.

Options

Application Options

Ice-Making with Hardwired Interface

Unit controls are factory set to handle ice-making for thermal storage application. An additional temperature sensor, at the compressor discharge, enables full load operation of the chiller with entering evaporator fluid temperature between 20°F (-7°C) and 65°F (18°C) with glycol.

High Ambient

The unit starts and operates from 32°F to 125°F (0°C to 52°C).

Low-Temperature Processing

An additional temperature sensor, at the compressor discharge, enables leaving evaporator fluid temperature between 10°F (-12.2°C) and 42°F (5.5°C) with glycol.

Partial Heat Recovery with Fan Control

A supplemental brazed plate heat exchanger is mounted in series to the condenser coil. Connecting piping and inlet and outlet water sensors are included. CH530 controls display heat recovery inlet and outlet water temperatures and controls the fans. The heat rejection to the partial heat recovery heat exchanger is not controlled. Flow and temperature variations through the partial heat recovery heat exchanger will vary. The partial heat recovery heat exchanger is typically used to preheat water before it enters a boiler or other water heating process.

Dual High Head Pump Package

Pump package includes: two high head pumps, VFD, expansion vessels, drainage valves, shut-off valves at entering and leaving connections.

The pump package is single point power integrated into the chiller unit power with a separate factory wired control panel. The control of the pump is integrated into the chiller controller. The CH530 displays evaporator pump starts and run-times. Freeze protection down to an ambient of -20°F (-29°C) is included as standard. The cold parts of the pump package will also be insulated.

Designed with one redundant pump, the chiller controls both pumps through a lead/lag and failure/recovery functionality.

A variable speed drive is installed in an additional panel to control the pump. The inverter is adjusted upon start up to balance the system flow and head requirements. The purpose is to save on wasted pump energy caused by a traditional balancing valve.

Electrical Options:**Circuit Breaker**

A molded case standard interrupting capacity circuit breaker, factory pre-wired with terminal block power connections and equipped with a lockable external operator handle, is available to disconnect the chiller from main power.

Circuit Breaker with High Fault Rated Control Panel

A molded case high interrupting capacity circuit breaker, factory pre-wired with terminal block power connections and equipped with a lockable external operator handle, is available to disconnect the chiller from main power.

Short Circuit Rating

Short circuit rating of 5 kA or up to 65 kA is available.

Control Options:**BACNet Interface**

Allows user to easily interface with BACNet via a single twisted-pair wiring to a factory-installed and tested communication board.

LonTalk/Tracer Summit Interface

LonTalk (LCI-C) or Tracer Summit communications capabilities are available with communication link via single twisted-pair wiring to factory-installed and tested communication board. This option will support the functionality required to obtain Lon Mark certification.

Time of Day Scheduling

Time of day scheduling capabilities are available for scheduling single chiller applications through Trane CH530 panel (without the need for building automation system - BAS). This feature allows the user to set up to ten events in a seven day time period.

External Chilled Water and Demand Limit Setpoint

Controls, sensors, and safeties allow reset of chilled water temperature, based on temperature signal, during periods of low outdoor air temperature (chilled water reset based on return chilled water temperature is standard). The demand limit setpoint is communicated to a factory-installed and tested communication board through a 2-10 Vdc or 4-20 mA signal.

Percent Capacity

Output the number of compressors that are operating as an analog 2-10 Vdc or 4-20 mA signal.

Programmable Relays

Predefined, factory-installed, programmable relays allow the operation to select four relay outputs. Available outputs are: Alarm-Latching, Alarm-Auto Reset, General Alarm, Warning, Chiller Limit Mode, Compressor Running, and Tracer Control.

Other Options

Architectural Louvered Panels

Louvered panels cover the complete condensing coil and service area beneath the condenser.

Half Louvers

Louvered panels cover the condenser coil only. Available on the 80-130 ton units only.

Comprehensive Acoustic Package

This option includes acoustical treatment for compressor.

Condenser Coil - CompleteCoat

Condenser coils are made of aluminum fins (plate fins) mechanically bonded to internally finned copper tubes. The condenser box is then submerged in an epoxy polymer bath where an electrostatic charge is used to uniformly deposit the epoxy onto the coil. This option resists bi-metallic corrosion and allows for operation in coastal environments.

Condenser Coil - Copper

Condenser coils are made of non-slit copper fins (plate fins) mechanically bonded to internally finned copper tubes. Copper fins and copper tubes reduce material deterioration due to galvanic corrosion.

Isolators

Molded elastomeric isolators sized to reduce vibration transmission to the supporting structure when the unit is installed. Isolators ship with the chiller.

Isolators - Seismically Rated

Spring isolators are designed and tested to control the motion of the chiller during a seismic event.

Insulation for High Humidity

The evaporator is covered with factory-installed 1.25 inch (31.8 mm) Armaflex II or equal (k=0.28) insulation. Foam insulation is used on the suction line.

Nitrogen Charge

Unit is shipped with oil and a nitrogen charge in lieu of refrigerant.

Performance Test

Performance tests are available to certify chiller performance before shipment.

Seismically Rated Unit - IBC

Unit is built and certified for seismic applications in accordance with the following International Building Code (IBC) releases 2000, 2003, 2006 and 2009.

Seismically Rated Unit - OSHPD

Unit is built and certified for seismic applications in accordance with OSHPD.



Trane optimizes the performance of homes and buildings around the world. A business of Ingersoll Rand, the leader in creating and sustaining safe, comfortable and energy efficient environments, Trane offers a broad portfolio of advanced controls and HVAC systems, comprehensive building services, and parts. For more information, visit www.Trane.com.

Trane has a policy of continuous product and product data improvement and reserves the right to change design and specifications without notice.

© 2012 Trane All rights reserved
CG-PRC017-EN 13 Jan 2012
Supersedes CG-PRC017-EN (01 Jun 2011)

We are committed to using environmentally
conscious print practices that reduce waste.

