

COOLING TOWERS

AT | UT | USS Advanced Technology (AT) Series

The Industry's Smartest Induced Draft, Counterflow Cooling Towers



ENGINEERING DATA



*Mark owned by the Cooling Technology Institute

Advanced Technology Series

AT | UT | USS

Engineering Data & Dimensions

Nomenclature

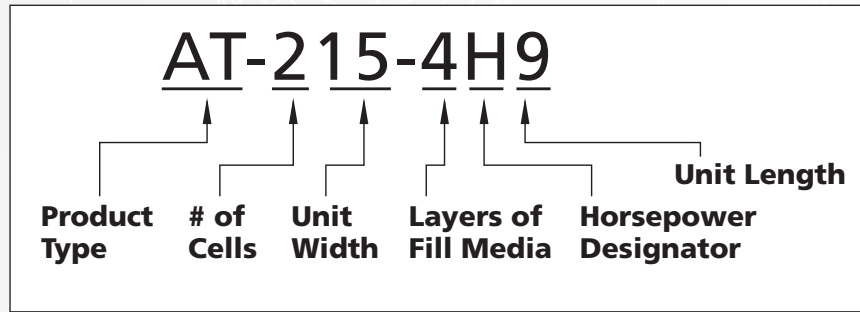

Product Type

AT – Indicates an Advanced Technology (AT) tower

UT – An AT tower with a super low sound fan

USS - An AT tower with stainless steel construction, 304, 316 or a combination. A USS tower may also include a Super Low Sound Fan.

of Cells

Determined by the number of inlet connections, can be 1, 2, 3, or 4

Unit Width

The total width of the unit in feet, all cells included. The value is rounded up to the next whole number.

Layers of Fill Media

Determined by the number of 1 foot tall fill layers. Can be 2, 3, 4 or 5.

Horsepower Designator

Determined by the horsepower per fan motor. Available from E = 2 Hp to R = 100 Hp.

Unit Length

The total length of the unit in feet, all cells included. The value is rounded up to the next whole number.

123-3/8"

26"

17-3/8"

4"

157-1/4"

161-1/2"

162-1/2"

167-1/4"

(3) 3 MPT MAKE-UP

(3) 4 MPT OVERFLOW

(3) 4 MPT DRAIN

5-1/8"

15' 8-7/8"

1-3/8"

42' 8"

Table of Contents

Nomenclature	1
---------------------------	----------

Engineering & Dimension Data	3-68
---	-------------

AT/USS 14-2E4 to 14-3G6	3
AT/USS 14-2E9 to 14-3G12	4
AT/UT/USS 17-2G9 to 17-4K9	5
AT/UT/USS 214-2G9 to 214-4K9	6
AT/UT/USS 17-2H12 to 17-4L12	7
AT/UT/USS 27-2H24 to 27-4L24	8
AT/UT/USS 214-2H12 to 214-4L12	9
AT/UT/USS 17-2G18 to 17-4K18	10
AT/UT/USS 27-2G36 to 27-4K36	11
AT/UT/USS 214-2G18 to 214-4K18	12
AT/UT/USS 19-2F6 to 19-4J6	13
AT/UT/USS 26-2F17 to 26-4J17	14
AT/UT/USS 212-2F9 to 212-4J9	15
AT/UT/USS 19-2F8 to 19-4J8	16
AT/UT/USS 28-2F17 to 28-4J17	17
AT/UT/USS 215-2F9 to 215-4J9	18
AT/UT/USS 19-2G9 to 19-4K9	19
AT/UT/USS 29-2G18 to 29-4K18	20
AT/UT/USS 217-2G9 to 217-4K9	21
AT/UT/USS 19-2G11 to 19-4L11	22
AT/UT/USS 29-2G21 to 29-4L21	23
AT/UT/USS 217-2G11 to 217-4L11	24
AT/UT/USS 19-2H12 to 19-4M12	25
AT/UT/USS 217-2H12 to 217-4M12	26
AT/UT/USS 29-2H24 to 29-4M24	27
AT/UT/USS 39-2H36 to 39-4M36	28
AT/UT/USS 19-2H14 to 19-4M14	29
AT/UT/USS 217-2H14 to 217-4M14	30
AT/UT/USS 29-2H28 to 29-4M28	31
AT/UT/USS 39-2H42 to 39-4M42	32
AT/UT/USS 110-2I12 to 110-4N12	33
AT/UT/USS 220-2I12 to 220-4N12	34
AT/UT/USS 210-2I24 to 210-4N24	35
AT/UT/USS 310-2I36 to 310-4N36	36
AT/UT/USS 110-2I18 to 110-4N18	37
AT/UT/USS 220-2I18 to 220-4N18	38
AT/UT/USS 210-2I36 to 210-4N36	39

AT/UT/USS 112-2I12 to 112-4N12	40
AT/UT/USS 212-2I24 to 212-4N24	41
AT/UT/USS 312-2I36 to 312-4N36	42
AT/UT/USS 424-2I24 to 424-4N24	43
AT/UT/USS 112-2I14 to 112-4N14	44
AT/UT/USS 212-2I28 to 212-4N28	45
AT/UT/USS 312-2I42 to 312-4N42	46
AT/UT/USS 424-2I28 to 424-4N28	47
AT/UT/USS 112-2J18 to 112-4P18	48
AT/UT/USS 224-2J18 to 224-4P18	49
AT/UT/USS 212-2J36 to 212-4P36	50
AT/UT/USS 312-2J54 to 312-4P54	51
AT/UT/USS 424-2J36 to 424-4P36	52
AT/UT/USS 112-2K20 to 112-4P20	53
AT/UT/USS 224-2K20 to 224-4P20	54
AT/UT/USS 212-2K40 to 212-4P40	55
AT/UT/USS 312-2K60 to 312-4P60	56
AT/UT/USS 424-2K40 to 424-4P40	57
AT/UT/USS 114-2K24 to 114-4R24	58
AT/UT/USS 228-2K24 to 228-4R24	59
AT/UT/USS 214-2K48 to 214-4R48	60
AT/UT/USS 314-2K72 to 314-4Q72	61
AT/UT/USS 428-2K48 to 428-4R48	62
AT/UT/USS 114-5K26 to 114-5O26	63
AT/UT/USS 228-5K26 to 228-5O26	64
AT/UT/USS 214-5K52 to 214-5O52	65
AT/UT/USS 314-5K78 to 314-5O78	66
AT/UT/USS 428-5K52 to 428-5O52	67
AT/UT/USS 456-5K26 to 456-5O26	68

Remote Sump Applications	69
---------------------------------------	-----------

Electric Basin Heaters	70
-------------------------------------	-----------

Low Sound Solutions	71
----------------------------------	-----------

Structural Steel Support	72
---------------------------------------	-----------

AT/UT/USS 14-2E4 to 314-5O78	72
------------------------------------	----

AT/UT/USS 212-2G9 to 428-5O52	73
-------------------------------------	----

AT/UT/USS 342-5K26 to 342-5O26	74
--------------------------------------	----

AT/UT/USS 456-5K26 to 456-5O26	74
--------------------------------------	----

Applications	75
---------------------------	-----------

Sample Mechanical Specification	76-77
--	--------------

Models: AT/USS 14-2E4 to 14-3G6

One-Cell Cooling Towers

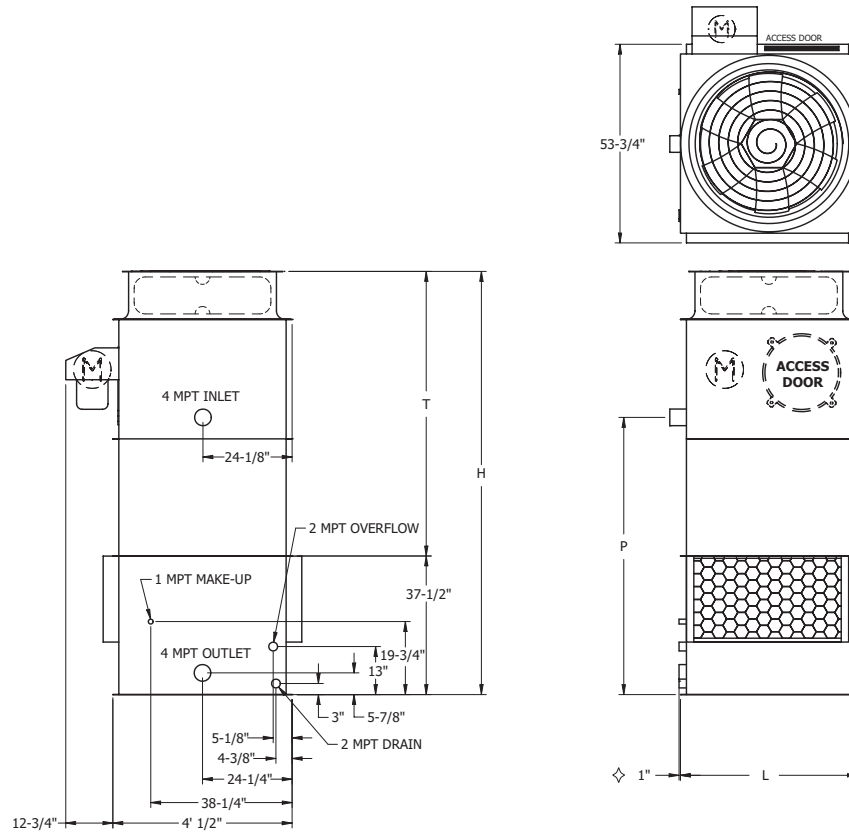

Model No.	Nominal Tonnage	WEIGHTS (LBS)			Fan Motor (HP)	Air Flow (CFM)	DIMENSIONS			
		Shipping	Operating	Heaviest Section†			H†	T†	P	L
AT 14-2E4	33	1,080	1,710	730	2	9,600	9' 6-1/2"	6' 5"	6' 3"	3' 11-7/8"
AT 14-2F4	39	1,130	1,760	780	3	10,900	9' 6-1/2"	6' 5"	6' 3"	3' 11-7/8"
AT 14-3E4	37	1,160	1,790	810	2	9,500	10' 6-1/2"	7' 5"	7' 3"	3' 11-7/8"
AT 14-3F4	43	1,210	1,840	860	3	10,700	10' 6-1/2"	7' 5"	7' 3"	3' 11-7/8"
AT 14-2F6	57	1,390	2,410	950	3	15,300	9' 6-1/2"	6' 5"	6' 3"	5' 11-7/8"
AT 14-2G6	67	1,410	2,430	970	5	18,000	9' 6-1/2"	6' 5"	6' 3"	5' 11-7/8"
AT 14-3F6	64	1,490	2,510	1,050	3	15,100	10' 6-1/2"	7' 5"	7' 3"	5' 11-7/8"
AT 14-3G6	74	1,510	2,530	1,070	5	17,700	10' 6-1/2"	7' 5"	7' 3"	5' 11-7/8"

- NOTE: (1) An adequately sized bleed line must be installed in the cooling tower system to prevent build-up of impurities in the recirculated water.
 (2) Do not use catalog drawings for certified prints. Dimensions and weights are subject to change.
 (3) Adequate spacing must be allowed for access to the cooling tower. Refer to EVAPCO's Equipment Layout Manual.
 (4) Nominal Tonnage is based on 3 gpm per ton at 95 degree entering water temperature, 85 degree leaving water temperature, and 78 degree wet-bulb temperature.

◇ Outlet connection extends beyond bottom flange.
 † Height includes fan guard which ships factory mounted.

◆ Heaviest section is upper section.

Models: AT/USS 14-2E9 to 14-3G12

One-Cell Cooling Towers

*14-2E9 to 14-3F9
(1) 4" Inlet
(1) 4" Outlet

*14-2F12 to 14-3G12
(1) 6" Inlet
(1) 6" Outlet

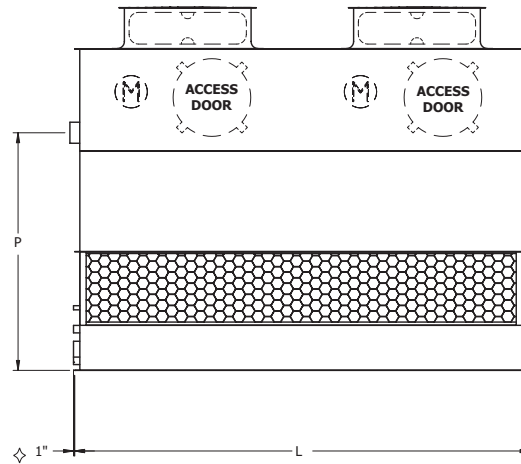
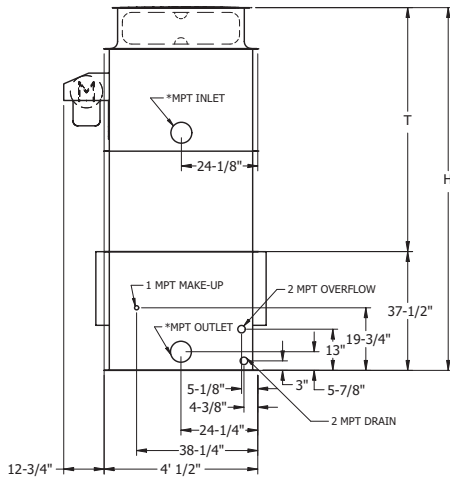
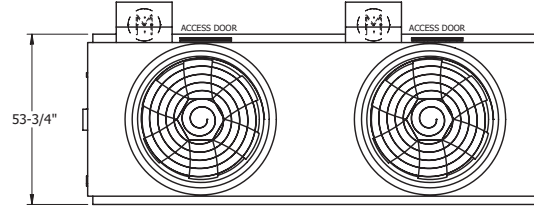

Model No.	Nominal Tonnage	WEIGHTS (LBS)			Fan Motor (HP)	Air Flow (CFM)	Dimensions			
		Shipping	Operating	Heaviest Section†			H†	T†	P	L
AT 14-2E9	76	2,000	3,550	1,380	(2) 2	21,200	9' 6-1/2"	6' 5"	6' 3"	8' 11-1/2"
AT 14-2F9	90	2,100	3,650	1,480	(2) 3	24,100	9' 6-1/2"	6' 5"	6' 3"	8' 11-1/2"
AT 14-3E9	86	2,160	3,710	1,540	(2) 2	20,800	10' 6-1/2"	7' 5"	7' 3"	8' 11-1/2"
AT 14-3F9	100	2,260	3,810	1,640	(2) 3	23,600	10' 6-1/2"	7' 5"	7' 3"	8' 11-1/2"
AT 14-2F12	115	2,530	4,650	1,770	(2) 3	31,000	9' 6-1/2"	6' 5"	6' 3"	11' 11-3/4"
AT 14-2G12	137	2,570	4,690	1,810	(2) 5	36,400	9' 6-1/2"	6' 5"	6' 3"	11' 11-3/4"
AT 14-3F12	129	2,730	4,850	1,970	(2) 3	30,400	10' 6-1/2"	7' 5"	7' 3"	11' 11-3/4"
AT 14-3G12	150	2,770	4,890	2,010	(2) 5	35,700	10' 6-1/2"	7' 5"	7' 3"	11' 11-3/4"

- NOTE: (1) An adequately sized bleed line must be installed in the cooling tower system to prevent build-up of impurities in the recirculated water.
 (2) Do not use catalog drawings for certified prints. Dimensions and weights are subject to change.
 (3) Adequate spacing must be allowed for access to the cooling tower. Refer to EVAPCO's Equipment Layout Manual.
 (4) Nominal Tonnage is based on 3 gpm per ton at 95 degree entering water temperature, 85 degree leaving water temperature, and 78 degree wet-bulb temperature.

◇ Outlet connection extends beyond bottom flange.
 † Height includes fan guard which ships factory mounted.

◆ Heaviest section is upper section.

Models: AT/UT/USS 17-2G9 to 17-4K9

One-Cell Cooling Towers

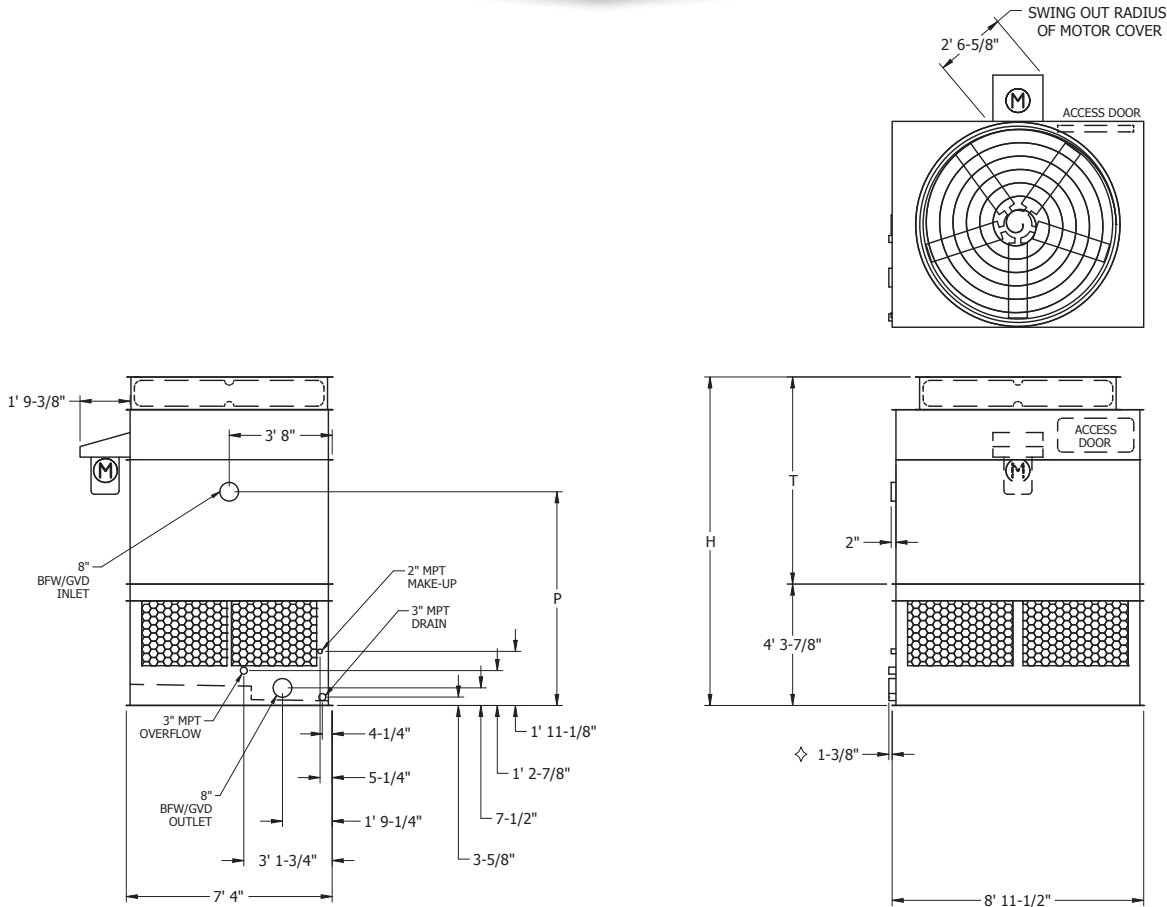

Model No.	Nominal Tonnage	WEIGHTS (LBS)			Fan Motor (HP)	Air Flow (CFM)	DIMENSIONS		
		Shipping	Operating	Heaviest Section†			H†	T†	P
AT 17-2G9	113	3,920	6,430	2,560	5	32,100	11' 8-3/8"	7' 4-1/2"	7' 7-3/8"
AT 17-2H9	135	3,960	6,470	2,600	7.5	36,500	11' 8-3/8"	7' 4-1/2"	7' 7-3/8"
AT 17-2I9	149	3,990	6,500	2,630	10	40,100	11' 8-3/8"	7' 4-1/2"	7' 7-3/8"
AT 17-2J9	171	4,060	6,570	2,700	15	45,600	11' 8-3/8"	7' 4-1/2"	7' 7-3/8"
AT 17-3G9	129	4,180	6,690	2,820	5	31,600	12' 8-3/8"	8' 4-1/2"	8' 7-3/8"
AT 17-3H9	152	4,220	6,730	2,860	7.5	36,000	12' 8-3/8"	8' 4-1/2"	8' 7-3/8"
AT 17-3I9	168	4,250	6,760	2,890	10	39,400	12' 8-3/8"	8' 4-1/2"	8' 7-3/8"
AT 17-3J9	193	4,320	6,830	2,960	15	44,700	12' 8-3/8"	8' 4-1/2"	8' 7-3/8"
AT 17-3K9	213	4,370	6,880	3,010	20	48,900	12' 8-3/8"	8' 4-1/2"	8' 7-3/8"
AT 17-4G9	143	4,440	6,950	3,080	5	31,100	13' 8-3/8"	9' 4-1/2"	9' 7-3/8"
AT 17-4H9	164	4,480	6,990	3,120	7.5	35,300	13' 8-3/8"	9' 4-1/2"	9' 7-3/8"
AT 17-4I9	179	4,510	7,020	3,150	10	38,700	13' 8-3/8"	9' 4-1/2"	9' 7-3/8"
AT 17-4J9	202	4,580	7,090	3,220	15	44,000	13' 8-3/8"	9' 4-1/2"	9' 7-3/8"
AT 17-4K9	220	4,630	7,140	3,270	20	48,100	13' 8-3/8"	9' 4-1/2"	9' 7-3/8"
SLSF Addition		130	130	130			1' 6"	1' 6"	

- NOTE: (1) An adequately sized bleed line must be installed in the cooling tower system to prevent build-up of impurities in the recirculated water.
 (2) Do not use catalog drawings for certified prints. Dimensions and weights are subject to change.
 (3) Adequate spacing must be allowed for access to the cooling tower. Refer to EVAPCO's Equipment Layout Manual.
 (4) Nominal Tonnage is based on 3 gpm per ton at 95 degree entering water temperature, 85 degree leaving water temperature, and 78 degree wet-bulb temperature.

◇ Outlet connection extends beyond bottom flange.
 † Height includes fan guard which ships factory mounted.

◆ Heaviest section is upper section.

Models: AT/UT/USS 214-2G9 to 214-4K9

Two-Cell Cooling Towers

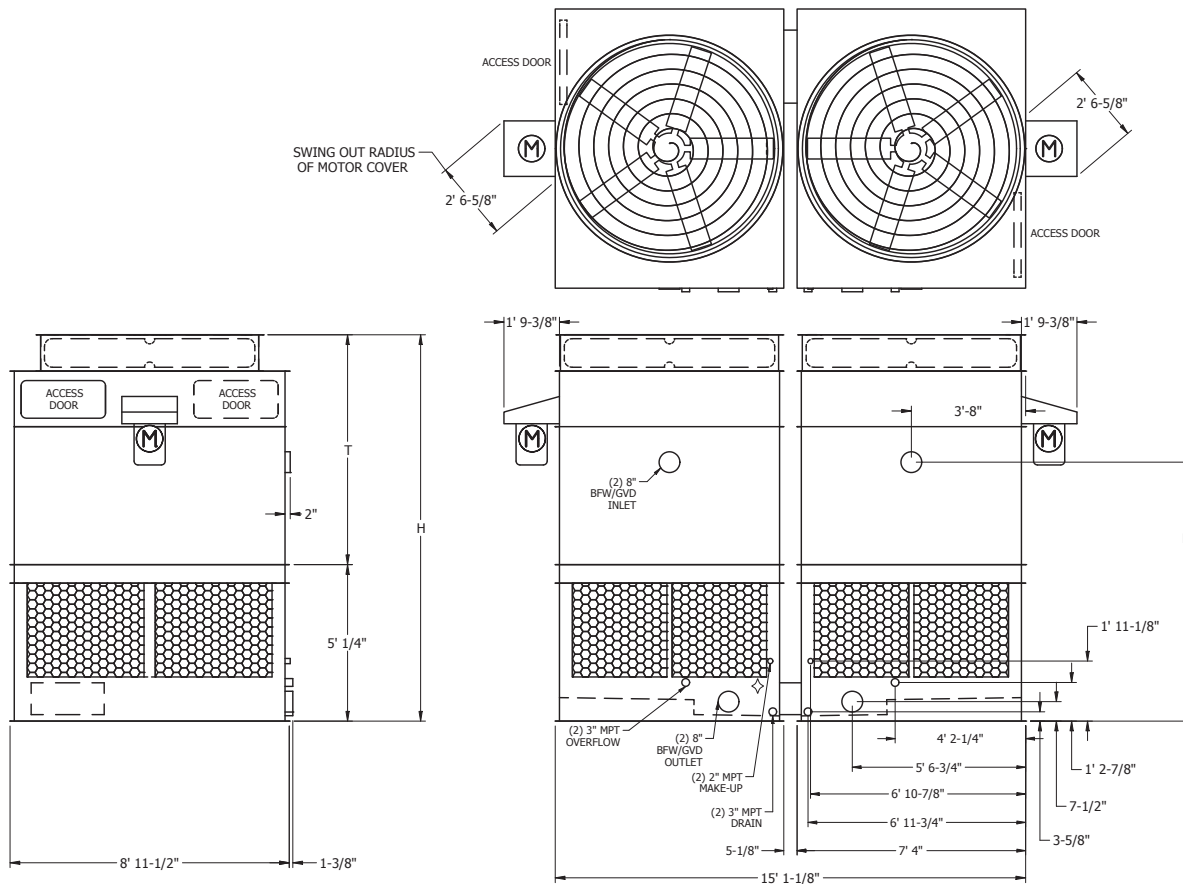

Model No.	Nominal Tonnage	WEIGHTS (LBS)			Fan Motor (HP)	Air Flow (CFM)	DIMENSIONS		
		Shipping	Operating	Heaviest Section†			H†	T†	P
AT 214-2G9	225	7,980	11,700	2,560	(2) 5	63,700	12' 4-3/4"	7' 4-1/2"	8' 3-3/4"
AT 214-2H9	269	8,060	11,780	2,600	(2) 7.5	72,400	12' 4-3/4"	7' 4-1/2"	8' 3-3/4"
AT 214-2I9	298	8,120	11,840	2,630	(2) 10	79,400	12' 4-3/4"	7' 4-1/2"	8' 3-3/4"
AT 214-2J9	342	8,260	11,980	2,700	(2) 15	90,300	12' 4-3/4"	7' 4-1/2"	8' 3-3/4"
AT 214-3G9	259	8,500	12,220	2,820	(2) 5	62,700	13' 4-3/4"	8' 4-1/2"	9' 3-3/4"
AT 214-3H9	303	8,580	12,300	2,860	(2) 7.5	71,300	13' 4-3/4"	8' 4-1/2"	9' 3-3/4"
AT 214-3I9	336	8,640	12,360	2,890	(2) 10	78,000	13' 4-3/4"	8' 4-1/2"	9' 3-3/4"
AT 214-3J9	385	8,780	12,500	2,960	(2) 15	88,600	13' 4-3/4"	8' 4-1/2"	9' 3-3/4"
AT 214-3K9	426	8,880	12,600	3,010	(2) 20	96,900	13' 4-3/4"	8' 4-1/2"	9' 3-3/4"
AT 214-4G9	287	9,020	12,740	3,080	(2) 5	61,600	14' 4-3/4"	9' 4-1/2"	10' 3-3/4"
AT 214-4H9	328	9,100	12,820	3,120	(2) 7.5	70,000	14' 4-3/4"	9' 4-1/2"	10' 3-3/4"
AT 214-4I9	358	9,160	12,880	3,150	(2) 10	76,700	14' 4-3/4"	9' 4-1/2"	10' 3-3/4"
AT 214-4J9	404	9,300	13,020	3,220	(2) 15	87,100	14' 4-3/4"	9' 4-1/2"	10' 3-3/4"
AT 214-4K9	441	9,400	13,120	3,270	(2) 20	95,300	14' 4-3/4"	9' 4-1/2"	10' 3-3/4"
SLSF Addition		260	260	130			1' 6"	1' 6"	

- NOTE: (1) An adequately sized bleed line must be installed in the cooling tower system to prevent build-up of impurities in the recirculated water.
 (2) Do not use catalog drawings for certified prints. Dimensions and weights are subject to change.
 (3) Adequate spacing must be allowed for access to the cooling tower. Refer to EVAPCO's Equipment Layout Manual.
 (4) Nominal Tonnage is based on 3 gpm per ton at 95 degree entering water temperature, 85 degree leaving water temperature, and 78 degree wet-bulb temperature.

◇ Outlet connection extends beyond bottom flange.
 † Height includes fan guard which ships factory mounted.

◆ Heaviest section is upper section.

Models: AT/UT/USS 17-2H12 to 17-4L12

One-Cell Cooling Towers

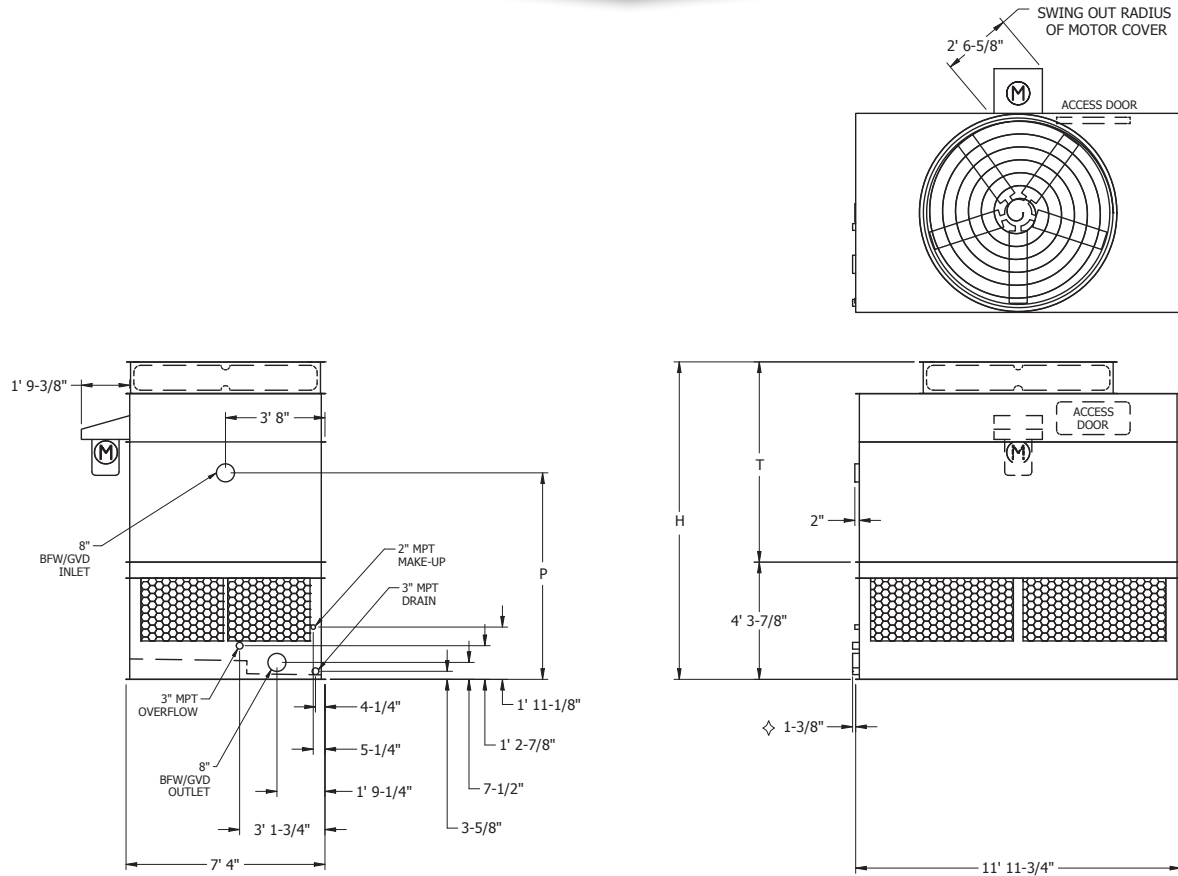

Model No.	Nominal Tonnage	WEIGHTS (LBS)			Fan Motor (HP)	Air Flow (CFM)	DIMENSIONS		
		Shipping	Operating	Heaviest Section†			H†	T†	P
AT 17-2H12	164	4,730	8,090	3,080	7.5	46,000	11' 8-3/8"	7' 4-1/2"	7' 7-3/8"
AT 17-2I12	180	4,760	8,120	3,110	10	50,500	11' 8-3/8"	7' 4-1/2"	7' 7-3/8"
AT 17-2J12	208	4,830	8,190	3,180	15	57,500	11' 8-3/8"	7' 4-1/2"	7' 7-3/8"
AT 17-2K12	229	4,880	8,240	3,230	20	63,000	11' 8-3/8"	7' 4-1/2"	7' 7-3/8"
AT 17-3H12	184	5,060	8,420	3,410	7.5	45,400	12' 8-3/8"	8' 4-1/2"	8' 7-3/8"
AT 17-3I12	203	5,090	8,450	3,440	10	49,700	12' 8-3/8"	8' 4-1/2"	8' 7-3/8"
AT 17-3J12	234	5,160	8,520	3,510	15	56,400	12' 8-3/8"	8' 4-1/2"	8' 7-3/8"
AT 17-3K12	258	5,210	8,570	3,560	20	61,700	12' 8-3/8"	8' 4-1/2"	8' 7-3/8"
AT 17-3L12	279	5,240	8,600	3,590	25	66,200	12' 8-3/8"	8' 4-1/2"	8' 7-3/8"
AT 17-4H12	201	5,390	8,750	3,740	7.5	44,600	13' 8-3/8"	9' 4-1/2"	9' 7-3/8"
AT 17-4I12	220	5,420	8,780	3,770	10	48,800	13' 8-3/8"	9' 4-1/2"	9' 7-3/8"
AT 17-4J12	249	5,490	8,850	3,840	15	55,500	13' 8-3/8"	9' 4-1/2"	9' 7-3/8"
AT 17-4K12	271	5,540	8,900	3,890	20	60,700	13' 8-3/8"	9' 4-1/2"	9' 7-3/8"
AT 17-4L12	290	5,570	8,930	3,920	25	65,100	13' 8-3/8"	9' 4-1/2"	9' 7-3/8"
SLSF Addition		130	130	130			1' 6"	1' 6"	

- NOTE: (1) An adequately sized bleed line must be installed in the cooling tower system to prevent build-up of impurities in the recirculated water.
 (2) Do not use catalog drawings for certified prints. Dimensions and weights are subject to change.
 (3) Adequate spacing must be allowed for access to the cooling tower. Refer to EVAPCO's Equipment Layout Manual.
 (4) Nominal Tonnage is based on 3 gpm per ton at 95 degree entering water temperature, 85 degree leaving water temperature, and 78 degree wet-bulb temperature.

◇ Outlet connection extends beyond bottom flange.
 † Height includes fan guard which ships factory mounted.

◆ Heaviest section is upper section.

Models: AT/UT/USS 27-2H24 to 27-4L24

One-Cell Cooling Towers

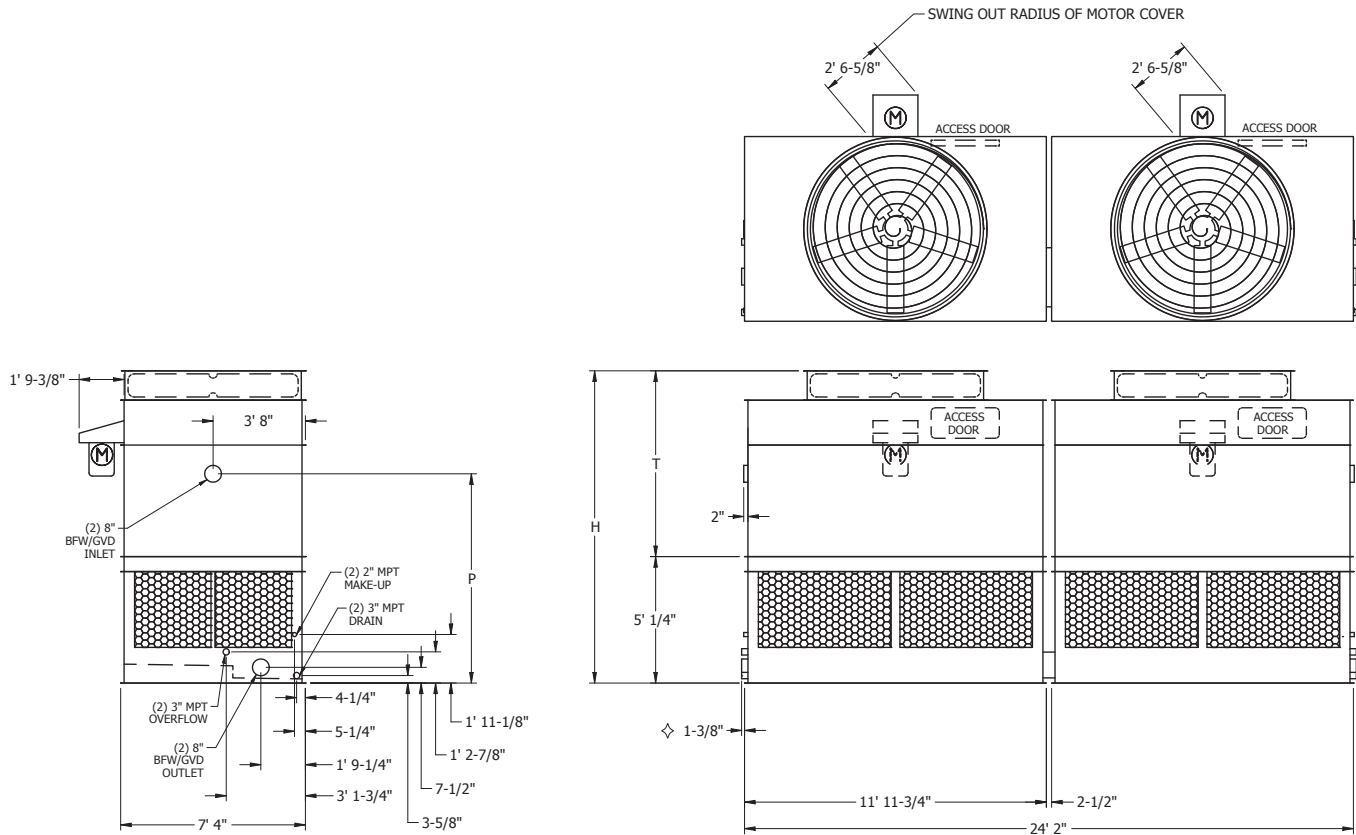

Model No.	Nominal Tonnage	WEIGHTS (LBS)			Fan Motor (HP)	Air Flow (CFM)	DIMENSIONS		
		Shipping	Operating	Heaviest Section†			H†	T†	P
AT 27-2H24	323	9,740	14,710	3,080	(2) 7.5	91,700	12' 4-3/4"	7' 4-1/2"	8' 3-3/4"
AT 27-2J24	356	9,800	14,770	3,110	(2) 10	100,600	12' 4-3/4"	7' 4-1/2"	8' 3-3/4"
AT 27-2K24	410	9,940	14,910	3,180	(2) 15	114,400	12' 4-3/4"	7' 4-1/2"	8' 3-3/4"
AT 27-2L24	453	10,040	15,010	3,230	(2) 20	125,400	12' 4-3/4"	7' 4-1/2"	8' 3-3/4"
AT 27-3H24	363	10,400	15,370	3,410	(2) 7.5	90,400	13' 4-3/4"	8' 4-1/2"	9' 3-3/4"
AT 27-3J24	402	10,460	15,430	3,440	(2) 10	99,000	13' 4-3/4"	8' 4-1/2"	9' 3-3/4"
AT 27-3K24	463	10,600	15,570	3,510	(2) 15	112,400	13' 4-3/4"	8' 4-1/2"	9' 3-3/4"
AT 27-3L24	511	10,700	15,670	3,560	(2) 20	123,000	13' 4-3/4"	8' 4-1/2"	9' 3-3/4"
AT 27-4H24	398	11,060	16,030	3,740	(2) 7.5	88,700	14' 4-3/4"	9' 4-1/2"	10' 3-3/4"
AT 27-4J24	436	11,120	16,090	3,770	(2) 10	97,200	14' 4-3/4"	9' 4-1/2"	10' 3-3/4"
AT 27-4K24	492	11,260	16,230	3,840	(2) 15	110,500	14' 4-3/4"	9' 4-1/2"	10' 3-3/4"
AT 27-4L24	574	11,360	16,330	3,890	(2) 20	121,000	14' 4-3/4"	9' 4-1/2"	10' 3-3/4"
SLSF Addition		260	260	130			1' 6"	1' 6"	

- NOTE: (1) An adequately sized bleed line must be installed in the cooling tower system to prevent build-up of impurities in the recirculated water.
 (2) Do not use catalog drawings for certified prints. Dimensions and weights are subject to change.
 (3) Adequate spacing must be allowed for access to the cooling tower. Refer to EVAPCO's Equipment Layout Manual.
 (4) Nominal Tonnage is based on 3 gpm per ton at 95 degree entering water temperature, 85 degree leaving water temperature, and 78 degree wet-bulb temperature.

◇ Outlet connection extends beyond bottom flange.
 † Height includes fan guard which ships factory mounted.

◆ Heaviest section is upper section.

Models: AT/UT/USS 214-2H12 to 214-4L12

Two-Cell Cooling Towers

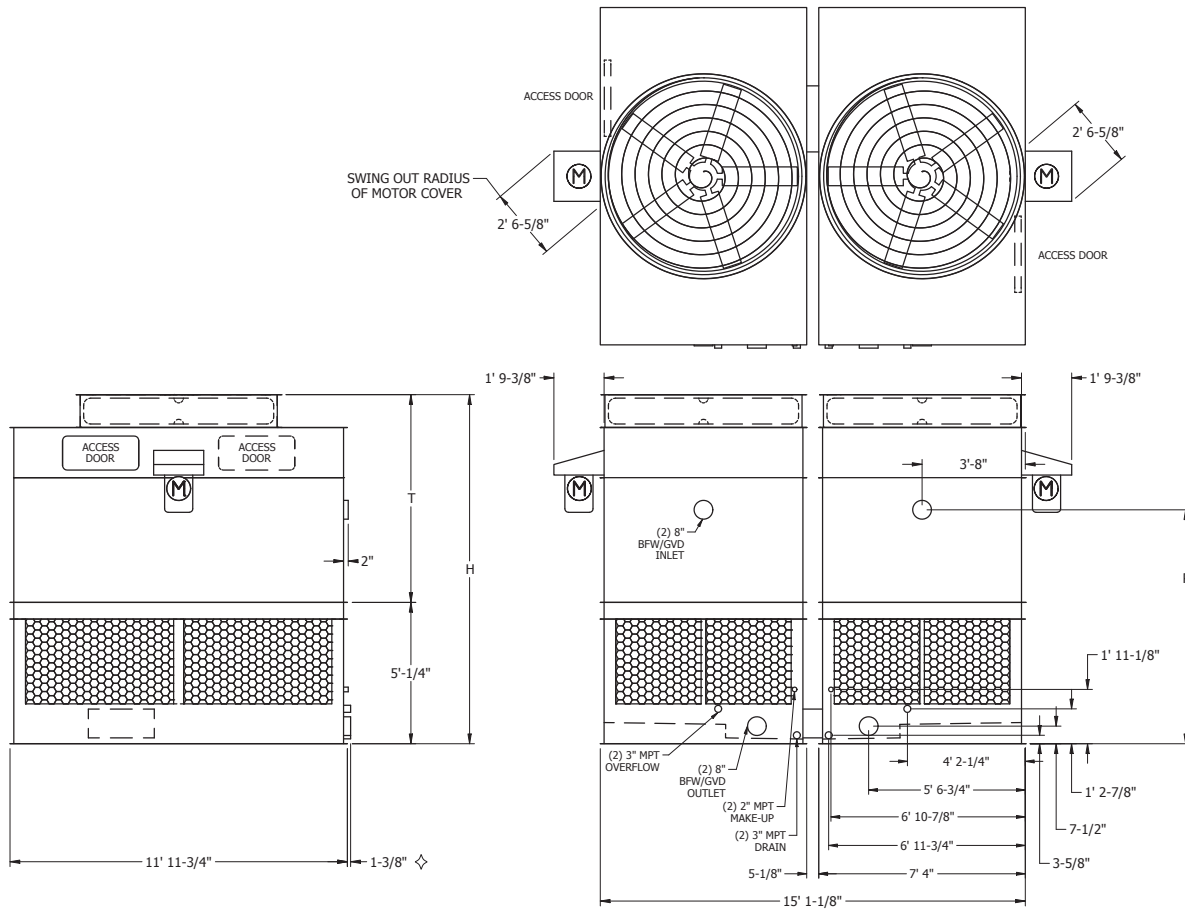

Model No.	Nominal Tonnage	WEIGHTS (LBS)			Fan Motor (HP)	Air Flow (CFM)	DIMENSIONS		
		Shipping	Operating	Heaviest Section†			H†	T†	P
AT 214-2H12	317	9,660	14,630	3,080	(2) 7.5	90,300	12' 4-3/4"	7' 4-1/2"	8' 3-3/4"
AT 214-2H12	350	9,720	14,690	3,110	(2) 10	99,100	12' 4-3/4"	7' 4-1/2"	8' 3-3/4"
AT 214-2J12	404	9,860	14,830	3,180	(2) 15	112,800	12' 4-3/4"	7' 4-1/2"	8' 3-3/4"
AT 214-2K12	446	9,960	14,930	3,230	(2) 20	123,600	12' 4-3/4"	7' 4-1/2"	8' 3-3/4"
AT 214-3H12	358	10,320	15,290	3,410	(2) 7.5	89,000	13' 4-3/4"	8' 4-1/2"	9' 3-3/4"
AT 214-3H12	396	10,380	15,350	3,440	(2) 10	97,500	13' 4-3/4"	8' 4-1/2"	9' 3-3/4"
AT 214-3J12	456	10,520	15,490	3,510	(2) 15	110,800	13' 4-3/4"	8' 4-1/2"	9' 3-3/4"
AT 214-3K12	504	10,620	15,590	3,560	(2) 20	121,200	13' 4-3/4"	8' 4-1/2"	9' 3-3/4"
AT 214-3L12	545	10,680	15,650	3,590	(2) 25	129,900	13' 4-3/4"	8' 4-1/2"	9' 3-3/4"
AT 214-4H12	393	10,980	15,950	3,740	(2) 7.5	87,400	14' 4-3/4"	9' 4-1/2"	10' 3-3/4"
AT 214-4H12	430	11,040	16,010	3,770	(2) 10	95,800	14' 4-3/4"	9' 4-1/2"	10' 3-3/4"
AT 214-4J12	486	11,180	16,150	3,840	(2) 15	108,900	14' 4-3/4"	9' 4-1/2"	10' 3-3/4"
AT 214-4K12	530	11,280	16,250	3,890	(2) 20	119,200	14' 4-3/4"	9' 4-1/2"	10' 3-3/4"
AT 214-4L12	567	11,340	16,310	3,920	(2) 25	127,900	14' 4-3/4"	9' 4-1/2"	10' 3-3/4"
SLSF Addition		260	260	130			1' 6"	1' 6"	

- NOTE: (1) An adequately sized bleed line must be installed in the cooling tower system to prevent build-up of impurities in the recirculated water.
 (2) Do not use catalog drawings for certified prints. Dimensions and weights are subject to change.
 (3) Adequate spacing must be allowed for access to the cooling tower. Refer to EVAPCO's Equipment Layout Manual.
 (4) Nominal Tonnage is based on 3 gpm per ton at 95 degree entering water temperature, 85 degree leaving water temperature, and 78 degree wet-bulb temperature.

◇ Outlet connection extends beyond bottom flange.
 † Height includes fan guard which ships factory mounted.

◆ Heaviest section is upper section.

Models: AT/UT/USS 17-2G18 to 17-4K18

One-Cell Cooling Towers

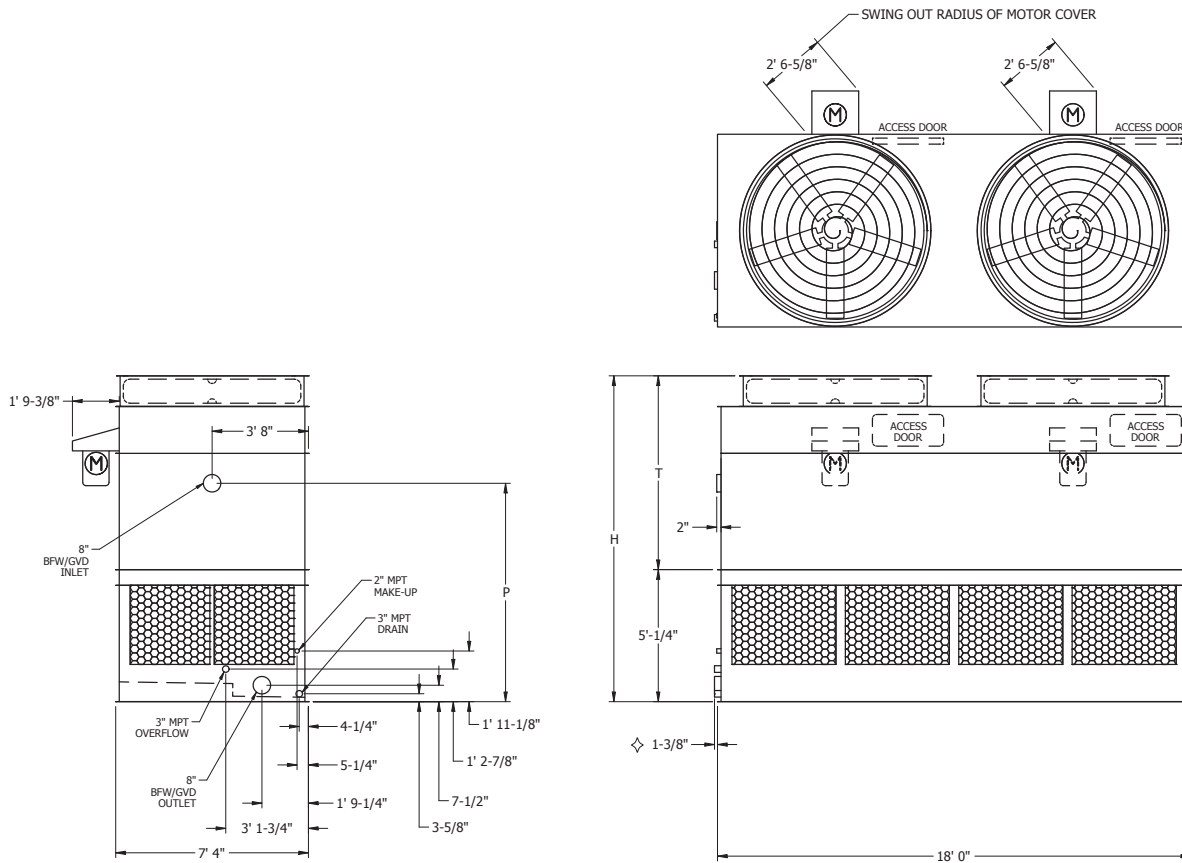

Model No.	Nominal Tonnage	WEIGHTS (LBS)			Fan Motor (HP)	Air Flow (CFM)	DIMENSIONS		
		Shipping	Operating	Heaviest Section†			H†	T†	P
AT 17-2G18	228	7,430	12,560	4,800	5	64,900	12' 4-3/4"	7' 4-1/2"	8' 3-3/4"
AT 17-2H18	272	7,510	12,640	4,880	7.5	73,800	12' 4-3/4"	7' 4-1/2"	8' 3-3/4"
AT 17-2I18	301	7,570	12,700	4,940	10	80,900	12' 4-3/4"	7' 4-1/2"	8' 3-3/4"
AT 17-2J18	346	7,710	12,840	5,080	15	92,100	12' 4-3/4"	7' 4-1/2"	8' 3-3/4"
AT 17-3G18	261	7,910	13,040	5,280	5	63,900	13' 4-3/4"	8' 4-1/2"	9' 3-3/4"
AT 17-3H18	306	7,990	13,120	5,360	7.5	72,700	13' 4-3/4"	8' 4-1/2"	9' 3-3/4"
AT 17-3I18	339	8,050	13,180	5,420	10	79,500	13' 4-3/4"	8' 4-1/2"	9' 3-3/4"
AT 17-3J18	389	8,190	13,320	5,560	15	90,300	13' 4-3/4"	8' 4-1/2"	9' 3-3/4"
AT 17-3K18	430	8,290	13,420	5,660	20	98,800	13' 4-3/4"	8' 4-1/2"	9' 3-3/4"
AT 17-4G18	289	8,380	13,510	5,750	5	62,800	14' 4-3/4"	9' 4-1/2"	10' 3-3/4"
AT 17-4H18	332	8,460	13,590	5,830	7.5	71,400	14' 4-3/4"	9' 4-1/2"	10' 3-3/4"
AT 17-4I18	362	8,520	13,650	5,890	10	78,200	14' 4-3/4"	9' 4-1/2"	10' 3-3/4"
AT 17-4J18	408	8,660	13,790	6,030	15	88,800	14' 4-3/4"	9' 4-1/2"	10' 3-3/4"
AT 17-4K18	445	8,760	13,890	6,130	20	97,200	14' 4-3/4"	9' 4-1/2"	10' 3-3/4"
SLSF Addition		260	260	130			1' 6"	1' 6"	

- NOTE: (1) An adequately sized bleed line must be installed in the cooling tower system to prevent build-up of impurities in the recirculated water.
 (2) Do not use catalog drawings for certified prints. Dimensions and weights are subject to change.
 (3) Adequate spacing must be allowed for access to the cooling tower. Refer to EVAPCO's Equipment Layout Manual.
 (4) Nominal Tonnage is based on 3 gpm per ton at 95 degree entering water temperature, 85 degree leaving water temperature, and 78 degree wet-bulb temperature.

◇ Outlet connection extends beyond bottom flange.
 † Height includes fan guard which ships factory mounted.

◆ Heaviest section is upper section.

Models: AT/UT/USS 27-2G36 to 27-4K36

Two-Cell Cooling Towers

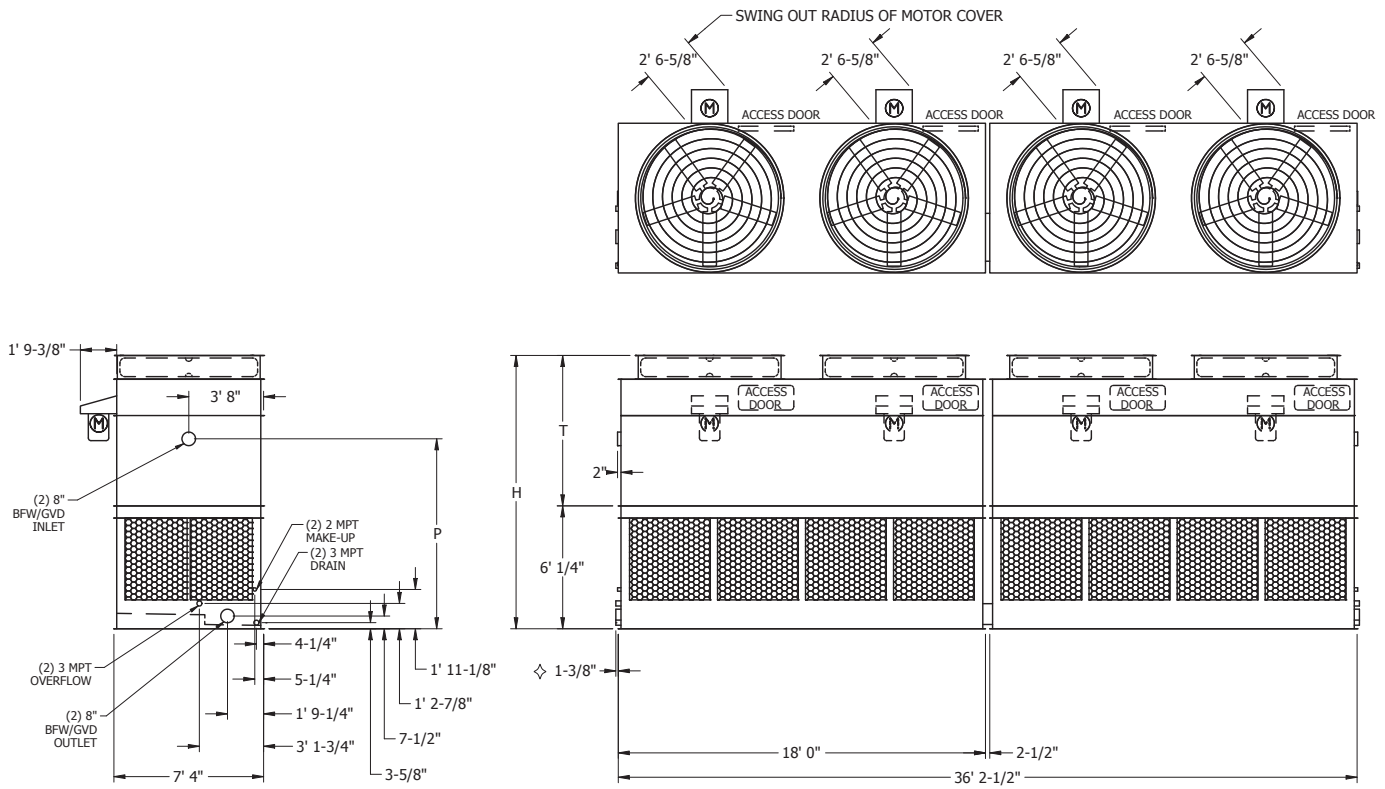

Model No.	Nominal Tonnage	WEIGHTS (LBS)			Fan Motor (HP)	Air Flow (CFM)	DIMENSIONS		
		Shipping	Operating	Heaviest Section†			H†	T†	P
AT 27-2G36	444	15,080	22,680	4,800	(4) 5	132,800	13' 4-3/4"	7' 4-1/2"	9' 3-3/4"
AT 27-2H36	531	15,240	22,840	4,880	(4) 7.5	151,000	13' 4-3/4"	7' 4-1/2"	9' 3-3/4"
AT 27-2I36	588	15,360	22,960	4,940	(4) 10	165,500	13' 4-3/4"	7' 4-1/2"	9' 3-3/4"
AT 27-2J36	676	15,640	23,240	5,080	(4) 15	188,300	13' 4-3/4"	7' 4-1/2"	9' 3-3/4"
AT 27-3G36	511	16,040	23,640	5,280	(4) 5	130,700	14' 4-3/4"	8' 4-1/2"	10' 3-3/4"
AT 27-3H36	600	16,200	23,800	5,360	(4) 7.5	148,700	14' 4-3/4"	8' 4-1/2"	10' 3-3/4"
AT 27-3I36	664	16,320	23,920	5,420	(4) 10	162,700	14' 4-3/4"	8' 4-1/2"	10' 3-3/4"
AT 27-3J36	763	16,600	24,200	5,560	(4) 15	184,700	14' 4-3/4"	8' 4-1/2"	10' 3-3/4"
AT 27-3K36	844	16,800	24,400	5,660	(4) 20	202,100	14' 4-3/4"	8' 4-1/2"	10' 3-3/4"
AT 27-4G36	568	16,980	24,580	5,750	(4) 5	128,400	15' 4-3/4"	9' 4-1/2"	11' 3-3/4"
AT 27-4H36	651	17,140	24,740	5,830	(4) 7.5	146,000	15' 4-3/4"	9' 4-1/2"	11' 3-3/4"
AT 27-4I36	710	17,260	24,860	5,890	(4) 10	159,900	15' 4-3/4"	9' 4-1/2"	11' 3-3/4"
AT 27-4J36	802	17,540	25,140	6,030	(4) 15	181,700	15' 4-3/4"	9' 4-1/2"	11' 3-3/4"
AT 27-4K36	875	17,740	25,340	6,130	(4) 20	198,800	15' 4-3/4"	9' 4-1/2"	11' 3-3/4"
SLSF Addition		390	390	130			1' 6"	1' 6"	

- NOTE: (1) An adequately sized bleed line must be installed in the cooling tower system to prevent build-up of impurities in the recirculated water.
 (2) Do not use catalog drawings for certified prints. Dimensions and weights are subject to change.
 (3) Adequate spacing must be allowed for access to the cooling tower. Refer to EVAPCO's Equipment Layout Manual.
 (4) Nominal Tonnage is based on 3 gpm per ton at 95 degree entering water temperature, 85 degree leaving water temperature, and 78 degree wet-bulb temperature.

◇ Outlet connection extends beyond bottom flange.
 † Height includes fan guard which ships factory mounted.

◆ Heaviest section is upper section.

Models: AT/UT/USS 214-2G18 to 214-4K18

Two-Cell Cooling Towers

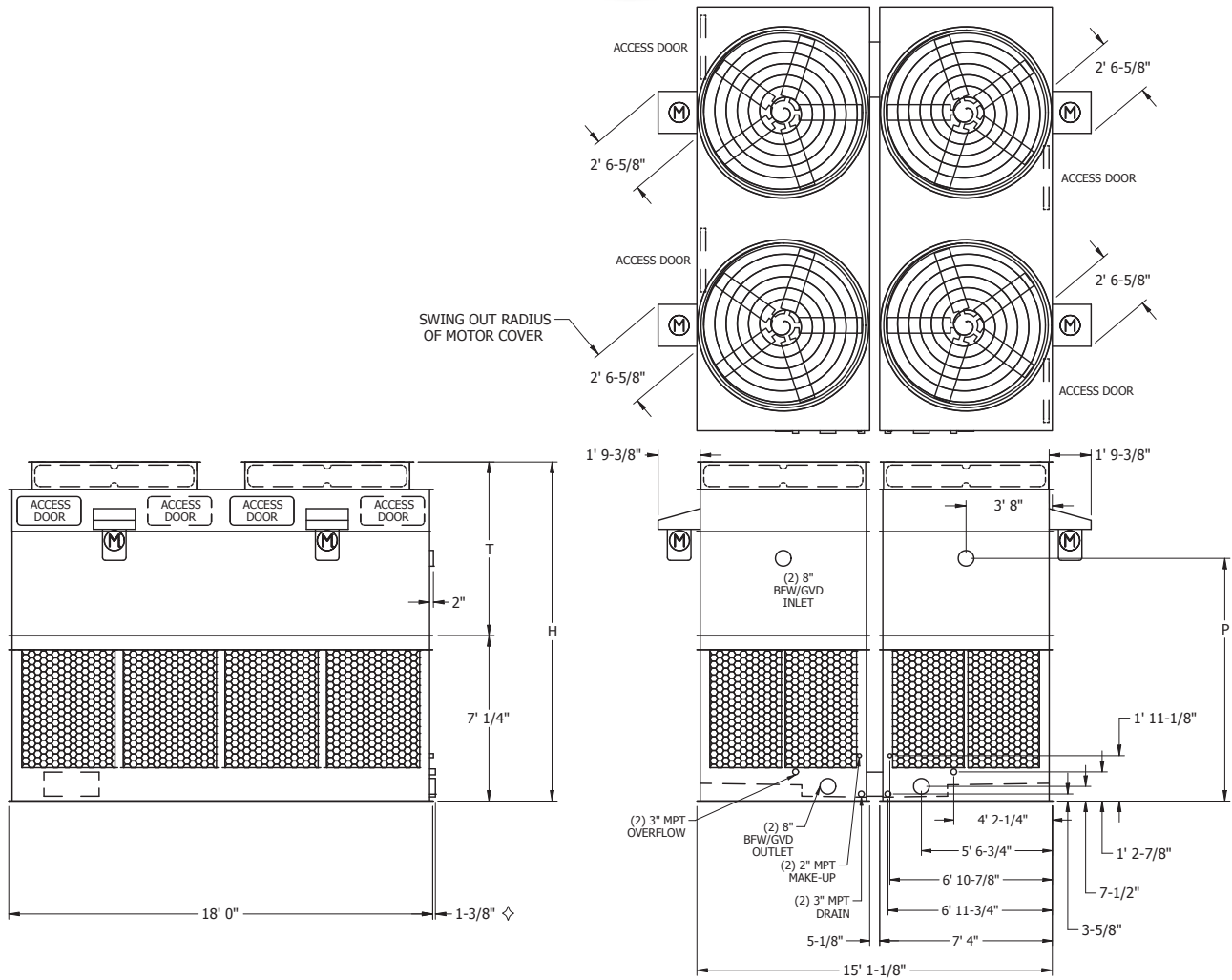

Model No.	Nominal Tonnage	WEIGHTS (LBS)			Fan Motor (HP)	Air Flow (CFM)	DIMENSIONS		
		Shipping	Operating	Heaviest Section†			H†	T†	P
AT 214-2G18	441	15,620	23,220	4,800	(4) 5	132,300	14' 4-3/4"	7' 4-1/2"	10' 3-3/4"
AT 214-2H18	528	15,780	23,380	4,880	(4) 7.5	150,500	14' 4-3/4"	7' 4-1/2"	10' 3-3/4"
AT 214-2I18	585	15,900	23,500	4,940	(4) 10	164,900	14' 4-3/4"	7' 4-1/2"	10' 3-3/4"
AT 214-2J18	673	16,180	23,780	5,080	(4) 15	187,600	14' 4-3/4"	7' 4-1/2"	10' 3-3/4"
AT 214-3G18	508	16,580	24,180	5,280	(4) 5	130,300	15' 4-3/4"	8' 4-1/2"	11' 3-3/4"
AT 214-3H18	597	16,740	24,340	5,360	(4) 7.5	148,100	15' 4-3/4"	8' 4-1/2"	11' 3-3/4"
AT 214-3I18	661	16,860	24,460	5,420	(4) 10	162,100	15' 4-3/4"	8' 4-1/2"	11' 3-3/4"
AT 214-3J18	760	17,140	24,740	5,560	(4) 15	184,000	15' 4-3/4"	8' 4-1/2"	11' 3-3/4"
AT 214-3K18	840	17,340	24,940	5,660	(4) 20	201,400	15' 4-3/4"	8' 4-1/2"	11' 3-3/4"
AT 214-4G18	565	17,520	25,120	5,750	(4) 5	127,900	16' 4-3/4"	9' 4-1/2"	12' 3-3/4"
AT 214-4H18	648	17,680	25,280	5,830	(4) 7.5	145,500	16' 4-3/4"	9' 4-1/2"	12' 3-3/4"
AT 214-4I18	707	17,800	25,400	5,890	(4) 10	159,400	16' 4-3/4"	9' 4-1/2"	12' 3-3/4"
AT 214-4J18	799	18,080	25,680	6,030	(4) 15	181,100	16' 4-3/4"	9' 4-1/2"	12' 3-3/4"
AT 214-4K18	871	18,280	25,880	6,130	(4) 20	198,100	16' 4-3/4"	9' 4-1/2"	12' 3-3/4"
SLSF Addition		520	520	130			1' 6"	1' 6"	

- NOTE: (1) An adequately sized bleed line must be installed in the cooling tower system to prevent build-up of impurities in the recirculated water.
 (2) Do not use catalog drawings for certified prints. Dimensions and weights are subject to change.
 (3) Adequate spacing must be allowed for access to the cooling tower. Refer to EVAPCO's Equipment Layout Manual.
 (4) Nominal Tonnage is based on 3 gpm per ton at 95 degree entering water temperature, 85 degree leaving water temperature, and 78 degree wet-bulb temperature.

◇ Outlet connection extends beyond bottom flange.
 † Height includes fan guard which ships factory mounted.

◆ Heaviest section is upper section.

Models: AT/UT/USS 19-2F6 to 19-4J6

One-Cell Cooling Towers

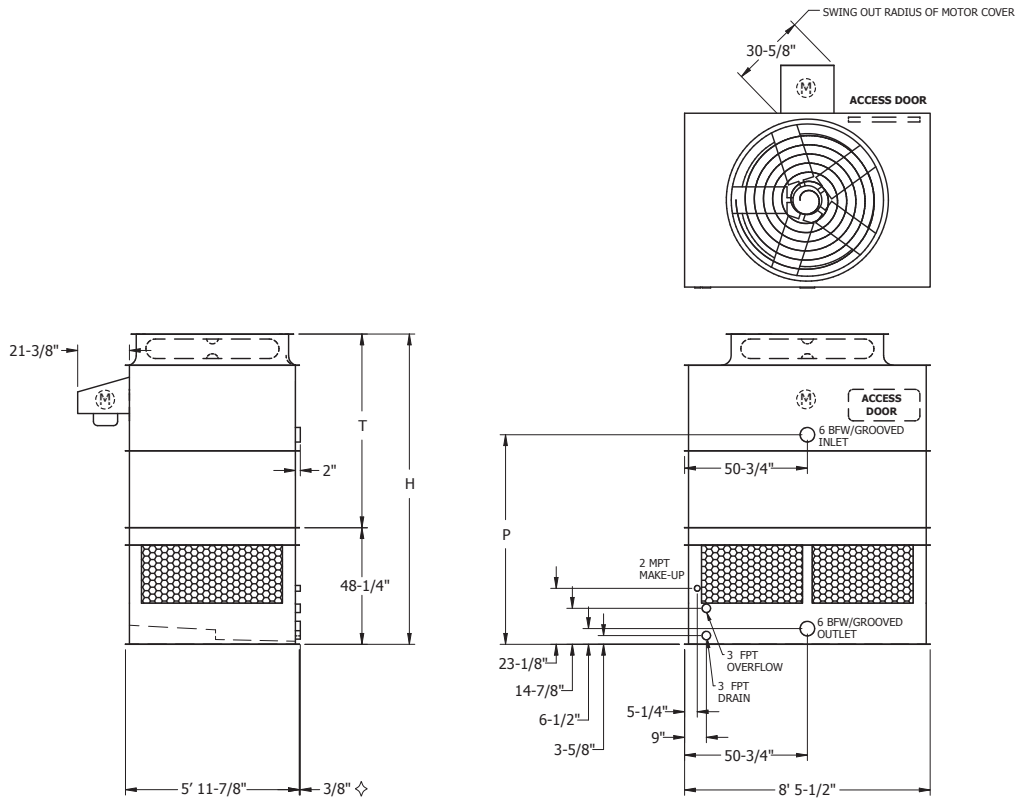

Model No.	Nominal Tonnage	WEIGHTS (LBS)			Fan Motor (HP)	Air Flow (CFM)	DIMENSIONS		
		Shipping	Operating	Heaviest Section†			H†	T†	P
AT 19-2F6	89	3,080	5,120	1,950	3	22,600	10' 8-1/4"	6' 8"	7' 2-1/2"
AT 19-2G6	112	3,140	5,180	2,010	5	26,500	10' 8-1/4"	6' 8"	7' 2-1/2"
AT 19-2H6	123	3,180	5,220	2,050	7.5	30,200	10' 8-1/4"	6' 8"	7' 2-1/2"
AT 19-3F6	101	3,280	5,320	2,150	3	22,200	11' 8-1/4"	7' 8"	8' 2-1/2"
AT 19-3G6	124	3,340	5,380	2,210	5	26,100	11' 8-1/4"	7' 8"	8' 2-1/2"
AT 19-3H6	138	3,380	5,420	2,250	7.5	29,700	11' 8-1/4"	7' 8"	8' 2-1/2"
AT 19-3I6	150	3,410	5,450	2,280	10	32,500	11' 8-1/4"	7' 8"	8' 2-1/2"
AT 19-4F6	109	3,500	5,540	2,370	3	21,900	12' 8-1/4"	8' 8"	9' 2-1/2"
AT 19-4G6	130	3,560	5,600	2,430	5	25,700	12' 8-1/4"	8' 8"	9' 2-1/2"
AT 19-4H6	143	3,600	5,640	2,470	7.5	29,200	12' 8-1/4"	8' 8"	9' 2-1/2"
AT 19-4I6	157	3,630	5,670	2,500	10	32,000	12' 8-1/4"	8' 8"	9' 2-1/2"
AT 19-4J6	171	3,700	5,740	2,570	15	36,400	12' 8-1/4"	8' 8"	9' 2-1/2"
SLSF Addition		150	150	150			1' 1"	1' 1"	

- NOTE: (1) An adequately sized bleed line must be installed in the cooling tower system to prevent build-up of impurities in the recirculated water.
 (2) Do not use catalog drawings for certified prints. Dimensions and weights are subject to change.
 (3) Adequate spacing must be allowed for access to the cooling tower. Refer to EVAPCO's Equipment Layout Manual.
 (4) Nominal Tonnage is based on 3 gpm per ton at 95 degree entering water temperature, 85 degree leaving water temperature, and 78 degree wet-bulb temperature.

◇ Outlet connection extends beyond bottom flange.
 † Height includes fan guard which ships factory mounted.

◆ Heaviest section is upper section.

Models: AT/UT/USS 26-2F17 to 26-4J17

Two-Cell Cooling Towers

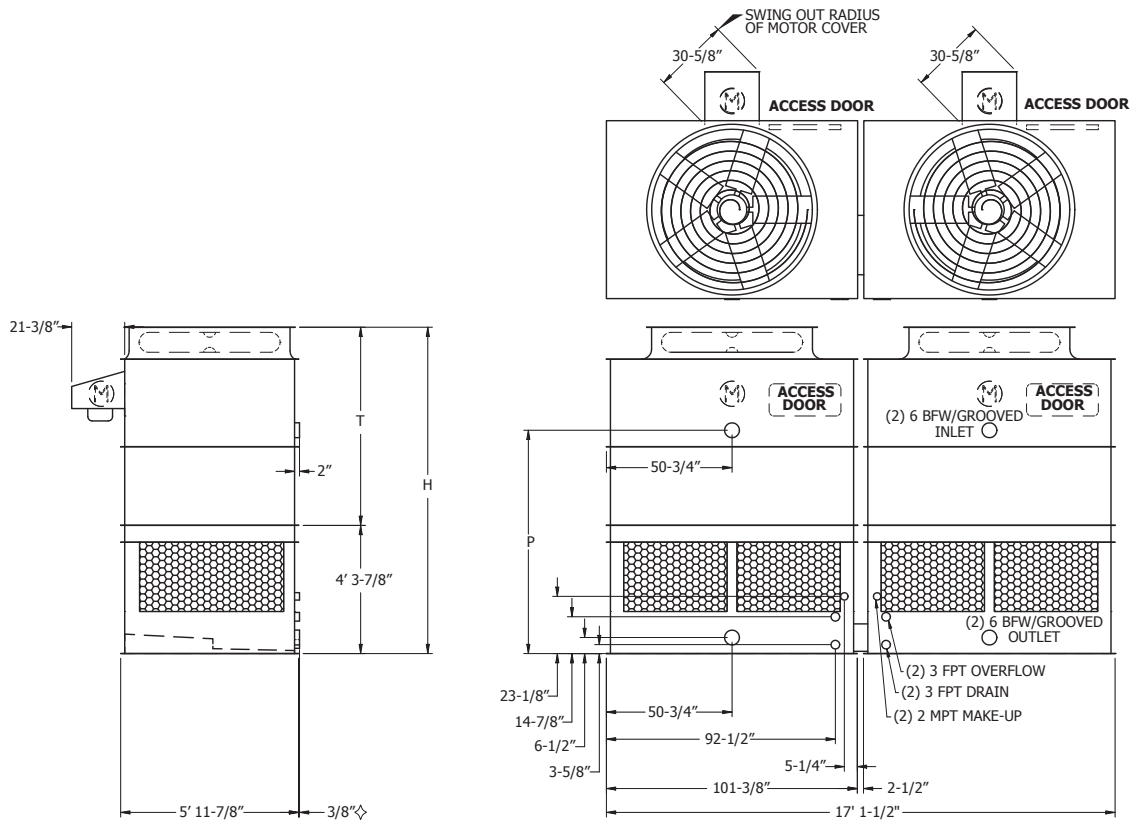

Model No.	Nominal Tonnage	WEIGHTS (LBS)			Fan Motor (HP)	Air Flow (CFM)	DIMENSIONS		
		Shipping	Operating	Heaviest Section [♦]			H [†]	T [†]	P
AT 26-2F17	179	6,280	10,360	1,990	(2) 3	45,200	10' 11-7/8"	6' 8"	7' 6-1/8"
AT 26-2G17	225	6,320	10,400	2,010	(2) 5	53,100	10' 11-7/8"	6' 8"	7' 6-1/8"
AT 26-2H17	247	6,400	10,480	2,050	(2) 7.5	60,500	10' 11-7/8"	6' 8"	7' 6-1/8"
AT 26-3F17	203	6,680	10,760	2,190	(2) 3	44,500	11' 11-7/8"	7' 8"	8' 6-1/8"
AT 26-3G17	250	6,720	10,800	2,210	(2) 5	52,300	11' 11-7/8"	7' 8"	8' 6-1/8"
AT 26-3H17	277	6,800	10,880	2,250	(2) 7.5	59,400	11' 11-7/8"	7' 8"	8' 6-1/8"
AT 26-3I17	302	6,860	10,940	2,280	(2) 10	65,100	11' 11-7/8"	7' 8"	8' 6-1/8"
AT 26-4F17	219	7,120	11,200	2,410	(2) 3	43,800	12' 11-7/8"	8' 8"	9' 6-1/8"
AT 26-4G17	262	7,160	11,240	2,430	(2) 5	51,400	12' 11-7/8"	8' 8"	9' 6-1/8"
AT 26-4H17	287	7,240	11,320	2,470	(2) 7.5	58,500	12' 11-7/8"	8' 8"	9' 6-1/8"
AT 26-4I17	315	7,300	11,380	2,500	(2) 10	64,000	12' 11-7/8"	8' 8"	9' 6-1/8"
AT 26-4J17	344	7,440	11,520	2,570	(2) 15	72,800	12' 11-7/8"	8' 8"	9' 6-1/8"
SLSF Addition		300	300	150			1' 1"	1' 1"	

- NOTE: (1) An adequately sized bleed line must be installed in the cooling tower system to prevent build-up of impurities in the recirculated water.
 (2) Do not use catalog drawings for certified prints. Dimensions and weights are subject to change.
 (3) Adequate spacing must be allowed for access to the cooling tower. Refer to EVAPCO's Equipment Layout Manual.
 (4) Nominal Tonnage is based on 3 gpm per ton at 95 degree entering water temperature, 85 degree leaving water temperature, and 78 degree wet-bulb temperature.

◇ Outlet connection extends beyond bottom flange.
 † Height includes fan guard which ships factory mounted.

♦ Heaviest section is upper section.

Models: AT/UT/USS 212-2F9 to 212-4J9

Two-Cell Cooling Towers

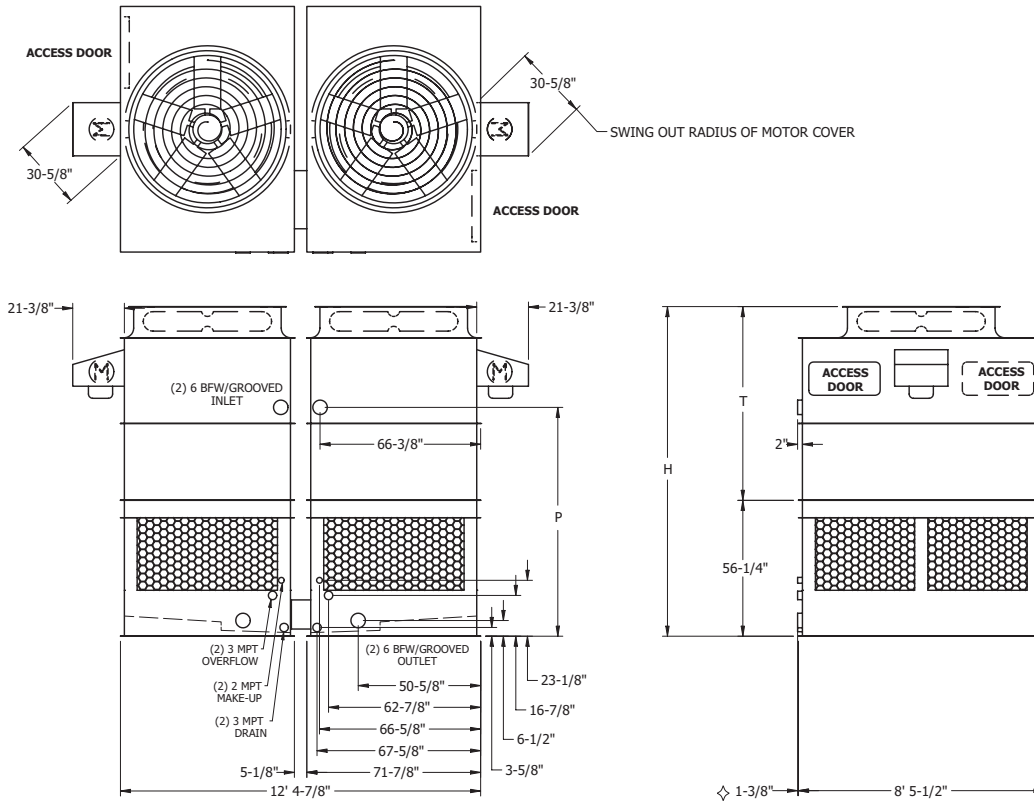

Model No.	Nominal Tonnage	WEIGHTS (LBS)			Fan Motor (HP)	Air Flow (CFM)	DIMENSIONS		
		Shipping	Operating	Heaviest Section†			H†	T†	P
AT 212-2F9	179	6,360	10,440	1,990	(2) 3	45,200	11' 4-1/4"	6' 8"	7' 10 1/2"
AT 212-2G9	225	6,400	10,480	2,010	(2) 5	53,100	11' 4-1/4"	6' 8"	7' 10 1/2"
AT 212-2H9	247	6,480	10,560	2,050	(2) 7.5	60,500	11' 4-1/4"	6' 8"	7' 10 1/2"
AT 212-3F9	203	6,760	10,840	2,190	(2) 3	44,500	12' 4-1/4"	7' 8"	8' 10 1/2"
AT 212-3G9	250	6,800	10,880	2,210	(2) 5	52,300	12' 4-1/4"	7' 8"	8' 10 1/2"
AT 212-3H9	277	6,880	10,960	2,250	(2) 7.5	59,400	12' 4-1/4"	7' 8"	8' 10 1/2"
AT 212-3I9	302	6,940	11,020	2,280	(2) 10	65,100	12' 4-1/4"	7' 8"	8' 10 1/2"
AT 212-4F9	219	7,200	11,280	2,410	(2) 3	43,800	13' 4-1/4"	8' 8"	9' 10 1/2"
AT 212-4G9	262	7,240	11,320	2,430	(2) 5	51,400	13' 4-1/4"	8' 8"	9' 10 1/2"
AT 212-4H9	287	7,320	11,400	2,470	(2) 7.5	58,500	13' 4-1/4"	8' 8"	9' 10 1/2"
AT 212-4I9	315	7,380	11,460	2,500	(2) 10	64,000	13' 4-1/4"	8' 8"	9' 10 1/2"
AT 212-4J9	344	7,520	11,600	2,570	(2) 15	72,800	13' 4-1/4"	8' 8"	9' 10 1/2"
SLSF Addition		300	300	150			1' 1"	1' 1"	

- NOTE: (1) An adequately sized bleed line must be installed in the cooling tower system to prevent build-up of impurities in the recirculated water.
 (2) Do not use catalog drawings for certified prints. Dimensions and weights are subject to change.
 (3) Adequate spacing must be allowed for access to the cooling tower. Refer to EVAPCO's Equipment Layout Manual.
 (4) Nominal Tonnage is based on 3 gpm per ton at 95 degree entering water temperature, 85 degree leaving water temperature, and 78 degree wet-bulb temperature.

- ◇ Outlet connection extends beyond bottom flange.
 † Heaviest section is upper section.
 † Height includes fan guard which ships factory mounted.

Models: AT/UT/USS 19-2F8 to 19-4J8

One-Cell Cooling Towers

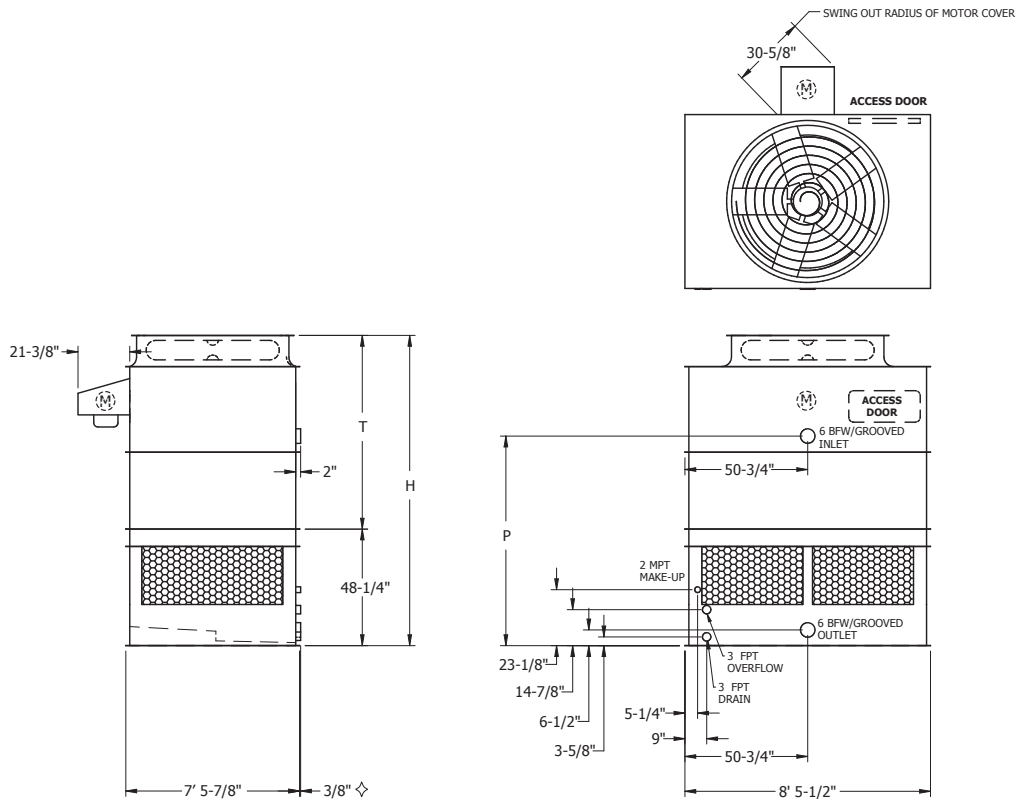

Model No.	Nominal Tonnage	WEIGHTS (LBS)			Fan Motor (HP)	Air Flow (CFM)	DIMENSIONS		
		Shipping	Operating	Heaviest Section [♦]			H [†]	T [†]	P
AT 19-2F8	109	3,490	5,910	2,220	3	26,600	10' 8-1/4"	6' 8"	7' 2-1/2"
AT 19-2G8	137	3,550	5,970	2,280	5	31,300	10' 8-1/4"	6' 8"	7' 2-1/2"
AT 19-2H8	148	3,590	6,010	2,320	7.5	35,700	10' 8-1/4"	6' 8"	7' 2-1/2"
AT 19-2I8	159	3,620	6,040	2,350	10	39,200	10' 8-1/4"	6' 8"	7' 2-1/2"
AT 19-3F8	123	3,720	6,140	2,450	3	26,200	11' 8-1/4"	7' 8"	8' 2-1/2"
AT 19-3G8	152	3,780	6,200	2,510	5	30,800	11' 8-1/4"	7' 8"	8' 2-1/2"
AT 19-3H8	165	3,820	6,240	2,550	7.5	35,100	11' 8-1/4"	7' 8"	8' 2-1/2"
AT 19-3I8	179	3,850	6,270	2,580	10	38,400	11' 8-1/4"	7' 8"	8' 2-1/2"
AT 19-3J8	197	3,910	6,330	2,640	15	43,700	11' 8-1/4"	7' 8"	8' 2-1/2"
AT 19-4F8	133	3,990	6,410	2,720	3	25,800	12' 8-1/4"	8' 8"	9' 2-1/2"
AT 19-4G8	159	4,050	6,470	2,780	5	30,300	12' 8-1/4"	8' 8"	9' 2-1/2"
AT 19-4H8	173	4,090	6,510	2,820	7.5	34,500	12' 8-1/4"	8' 8"	9' 2-1/2"
AT 19-4I8	187	4,120	6,540	2,850	10	37,800	12' 8-1/4"	8' 8"	9' 2-1/2"
AT 19-4J8	207	4,180	6,600	2,910	15	43,000	12' 8-1/4"	8' 8"	9' 2-1/2"
SLSF Addition		150	150	150			1' 5"	1' 5"	

- NOTE: (1) An adequately sized bleed line must be installed in the cooling tower system to prevent build-up of impurities in the recirculated water.
 (2) Do not use catalog drawings for certified prints. Dimensions and weights are subject to change.
 (3) Adequate spacing must be allowed for access to the cooling tower. Refer to EVAPCO's Equipment Layout Manual.
 (4) Nominal Tonnage is based on 3 gpm per ton at 95 degree entering water temperature, 85 degree leaving water temperature, and 78 degree wet-bulb temperature.

♦ Outlet connection extends beyond bottom flange.
 † Height includes fan guard which ships factory mounted.

♦ Heaviest section is upper section.

Models: AT/UT/USS 28-2F17 to 28-4J17

Two-Cell Cooling Towers

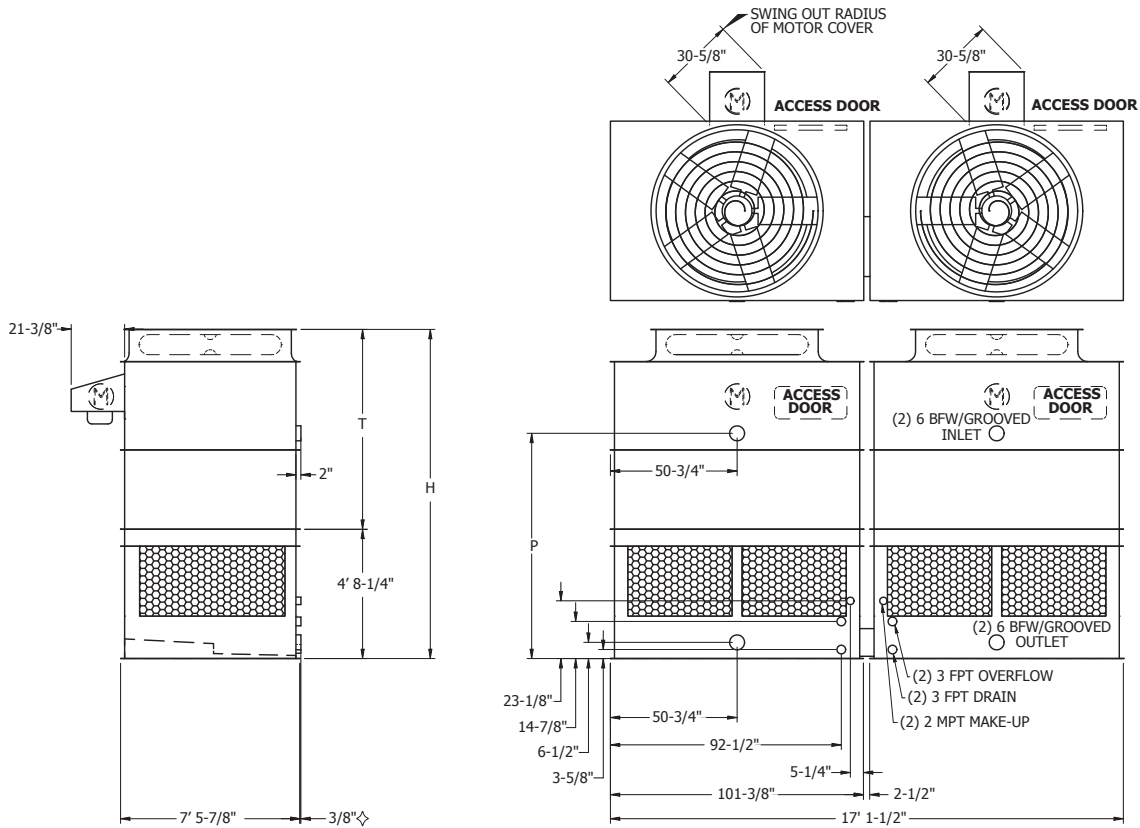

Model No.	Nominal Tonnage	WEIGHTS (LBS)			Fan Motor (HP)	Air Flow (CFM)	DIMENSIONS		
		Shipping	Operating	Heaviest Section [♦]			H [†]	T [†]	P
AT 28-2F17	217	7,140	11,980	2,260	(2) 3	53,200	11' 4-1/4"	6' 8"	7' 10-1/2"
AT 28-2G17	274	7,180	12,020	2,280	(2) 5	62,600	11' 4-1/4"	6' 8"	7' 10-1/2"
AT 28-2H17	297	7,260	12,100	2,320	(2) 7.5	71,400	11' 4-1/4"	6' 8"	7' 10-1/2"
AT 28-2I17	319	7,320	12,160	2,350	(2) 10	78,300	11' 4-1/4"	6' 8"	7' 10-1/2"
AT 28-3F17	247	7,600	12,440	2,490	(2) 3	52,500	12' 4-1/4"	7' 8"	8' 10-1/2"
AT 28-3G17	304	7,640	12,480	2,510	(2) 5	61,600	12' 4-1/4"	7' 8"	8' 10-1/2"
AT 28-3H17	331	7,720	12,560	2,550	(2) 7.5	70,200	12' 4-1/4"	7' 8"	8' 10-1/2"
AT 28-3I17	358	7,780	12,620	2,580	(2) 10	76,900	12' 4-1/4"	7' 8"	8' 10-1/2"
AT 28-3J17	393	7,900	12,740	2,640	(2) 15	87,500	12' 4-1/4"	7' 8"	8' 10-1/2"
AT 28-4F17	267	8,140	12,980	2,760	(2) 3	51,600	13' 4-1/4"	8' 8"	9' 10-1/2"
AT 28-4G17	319	8,180	13,020	2,780	(2) 5	60,600	13' 4-1/4"	8' 8"	9' 10-1/2"
AT 28-4H17	346	8,260	13,100	2,820	(2) 7.5	69,100	13' 4-1/4"	8' 8"	9' 10-1/2"
AT 28-4I17	373	8,320	13,160	2,850	(2) 10	75,700	13' 4-1/4"	8' 8"	9' 10-1/2"
AT 28-4J17	414	8,440	13,280	2,910	(2) 15	86,000	13' 4-1/4"	8' 8"	9' 10-1/2"
SLSF Addition		300	300	150			1' 5"	1' 5"	

- NOTE: (1) An adequately sized bleed line must be installed in the cooling tower system to prevent build-up of impurities in the recirculated water.
 (2) Do not use catalog drawings for certified prints. Dimensions and weights are subject to change.
 (3) Adequate spacing must be allowed for access to the cooling tower. Refer to EVAPCO's Equipment Layout Manual.
 (4) Nominal Tonnage is based on 3 gpm per ton at 95 degree entering water temperature, 85 degree leaving water temperature, and 78 degree wet-bulb temperature.

◇ Outlet connection extends beyond bottom flange.
 † Height includes fan guard which ships factory mounted.

♦ Heaviest section is upper section.

Models: AT/UT/USS 215-2F9 to 215-4J9

Two-Cell Cooling Towers

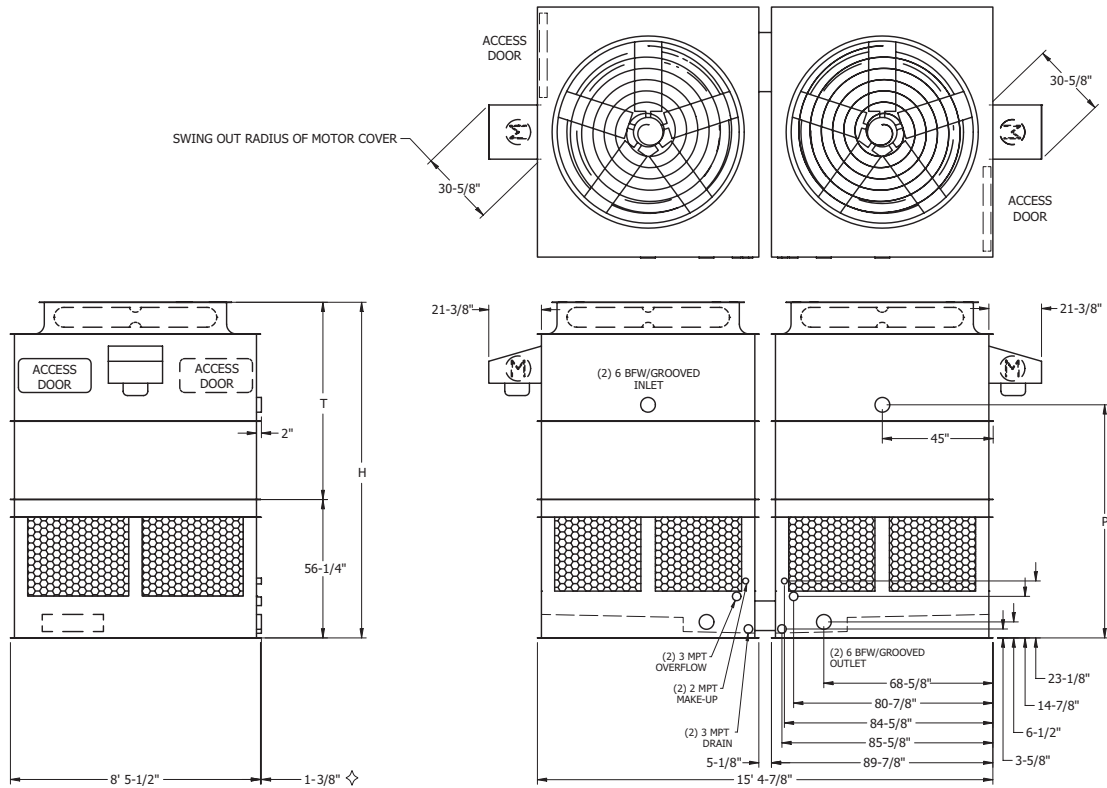

Model No.	Nominal Tonnage	WEIGHTS (LBS)			Fan Motor (HP)	Air Flow (CFM)	DIMENSIONS		
		Shipping	Operating	Heaviest Section†			H†	T†	P
AT 215-2F9	217	7,200	12,040	2,260	(2) 3	53,200	11' 4-1/4"	6' 8"	7' 10-1/2"
AT 215-2G9	274	7,240	12,080	2,280	(2) 5	62,600	11' 4-1/4"	6' 8"	7' 10-1/2"
AT 215-2H9	297	7,320	12,160	2,320	(2) 7.5	71,400	11' 4-1/4"	6' 8"	7' 10-1/2"
AT 215-2I9	319	7,380	12,220	2,350	(2) 10	78,300	11' 4-1/4"	6' 8"	7' 10-1/2"
AT 215-3F9	247	7,660	12,500	2,490	(2) 3	52,500	12' 4-1/4"	7' 8"	8' 10-1/2"
AT 215-3G9	304	7,700	12,540	2,510	(2) 5	61,600	12' 4-1/4"	7' 8"	8' 10-1/2"
AT 215-3H9	331	7,780	12,620	2,550	(2) 7.5	70,200	12' 4-1/4"	7' 8"	8' 10-1/2"
AT 215-3I9	358	7,840	12,680	2,580	(2) 10	76,900	12' 4-1/4"	7' 8"	8' 10-1/2"
AT 215-3J9	393	7,960	12,800	2,640	(2) 15	87,500	12' 4-1/4"	7' 8"	8' 10-1/2"
AT 215-4F9	267	8,200	13,040	2,760	(2) 3	51,600	13' 4-1/4"	8' 8"	9' 10-1/2"
AT 215-4G9	319	8,240	13,080	2,780	(2) 5	60,600	13' 4-1/4"	8' 8"	9' 10-1/2"
AT 215-4H9	346	8,320	13,160	2,820	(2) 7.5	69,100	13' 4-1/4"	8' 8"	9' 10-1/2"
AT 215-4I9	373	8,380	13,220	2,850	(2) 10	75,700	13' 4-1/4"	8' 8"	9' 10-1/2"
AT 215-4J9	414	8,500	13,340	2,910	(2) 15	86,000	13' 4-1/4"	8' 8"	9' 10-1/2"
SLSF Addition		300	300	150			1' 5"	1' 5"	

- NOTE: (1) An adequately sized bleed line must be installed in the cooling tower system to prevent build-up of impurities in the recirculated water.
 (2) Do not use catalog drawings for certified prints. Dimensions and weights are subject to change.
 (3) Adequate spacing must be allowed for access to the cooling tower. Refer to EVAPCO's Equipment Layout Manual.
 (4) Nominal Tonnage is based on 3 gpm per ton at 95 degree entering water temperature, 85 degree leaving water temperature, and 78 degree wet-bulb temperature.

◇ Outlet connection extends beyond bottom flange.
 † Height includes fan guard which ships factory mounted.

◆ Heaviest section is upper section.

* Model available with gear drive only. Motors and access doors located on 13' 11-1/4" unit ends. Super Low Sound Fan is not available on this unit.

Models: AT/UT/USS 19-2G9 to 19-4K9

One-Cell Cooling Towers

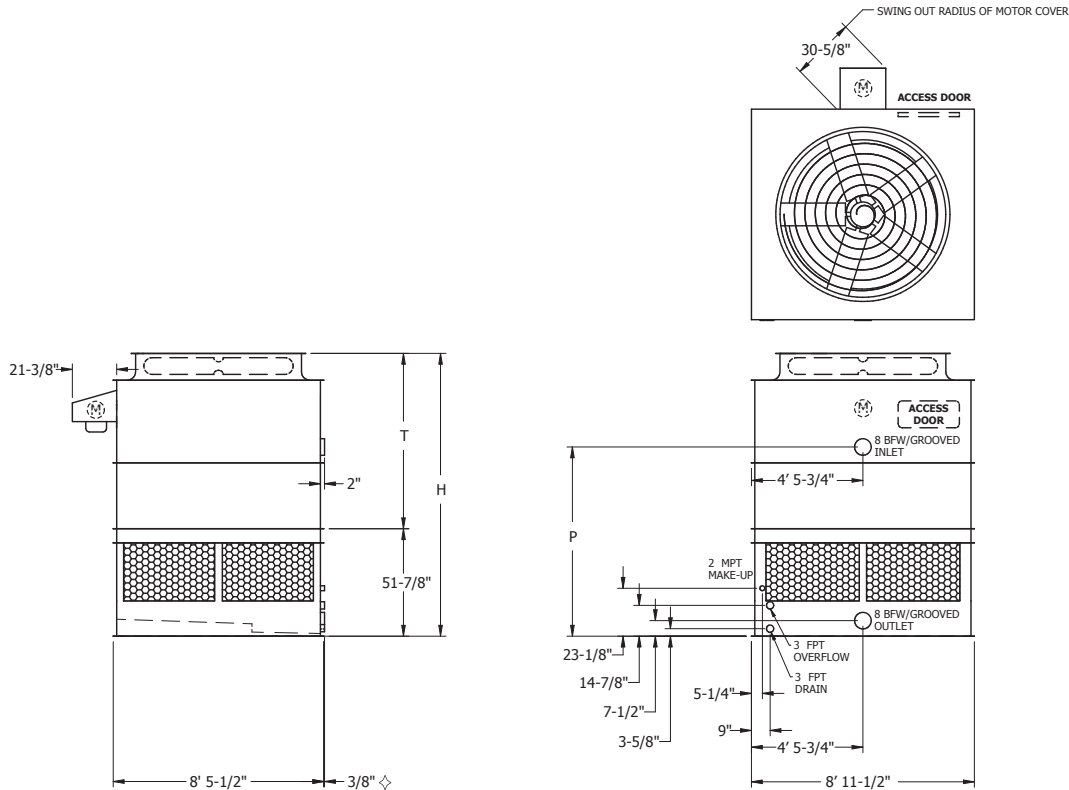

Model No.	Nominal Tonnage	WEIGHTS (LBS)			Fan Motor (HP)	Air Flow (CFM)	DIMENSIONS		
		Shipping	Operating	Heaviest Section†			H†	T†	P
AT 19-2G9	135	4,110	6,950	2,670	5	35,900	11' 4-3/8"	7' 1/2"	7' 7-1/8"
AT 19-2H9	162	4,150	6,990	2,710	7.5	40,800	11' 4-3/8"	7' 1/2"	7' 7-1/8"
AT 19-2I9	178	4,180	7,020	2,740	10	44,700	11' 4-3/8"	7' 1/2"	7' 7-1/8"
AT 19-2J9	208	4,250	7,090	2,810	15	50,800	11' 4-3/8"	7' 1/2"	7' 7-1/8"
AT 19-3G9	154	4,380	7,220	2,940	5	35,300	12' 4-3/8"	8' 1/2"	8' 7-1/8"
AT 19-3H9	181	4,420	7,260	2,980	7.5	40,100	12' 4-3/8"	8' 1/2"	8' 7-1/8"
AT 19-3I9	199	4,450	7,290	3,010	10	43,900	12' 4-3/8"	8' 1/2"	8' 7-1/8"
AT 19-3J9	232	4,520	7,360	3,080	15	49,800	12' 4-3/8"	8' 1/2"	8' 7-1/8"
AT 19-4G9	165	4,690	7,530	3,250	5	34,700	13' 4-3/8"	9' 1/2"	9' 7-1/8"
AT 19-4H9	191	4,730	7,570	3,290	7.5	39,500	13' 4-3/8"	9' 1/2"	9' 7-1/8"
AT 19-4I9	209	4,760	7,600	3,320	10	43,200	13' 4-3/8"	9' 1/2"	9' 7-1/8"
AT 19-4J9	242	4,830	7,670	3,390	15	49,000	13' 4-3/8"	9' 1/2"	9' 7-1/8"
AT 19-4K9	265	4,880	7,720	3,440	20	53,600	13' 4-3/8"	9' 1/2"	9' 7-1/8"
SLSF Addition		150	150	150			1' 9"	1' 9"	

- NOTE: (1) An adequately sized bleed line must be installed in the cooling tower system to prevent build-up of impurities in the recirculated water.
 (2) Do not use catalog drawings for certified prints. Dimensions and weights are subject to change.
 (3) Adequate spacing must be allowed for access to the cooling tower. Refer to EVAPCO's Equipment Layout Manual.
 (4) Nominal Tonnage is based on 3 gpm per ton at 95 degree entering water temperature, 85 degree leaving water temperature, and 78 degree wet-bulb temperature.

◇ Outlet connection extends beyond bottom flange.
 † Height includes fan guard which ships factory mounted.

◆ Heaviest section is upper section.

Models: AT/UT/USS 29-2G18 to 29-4K18

Two-Cell Cooling Towers

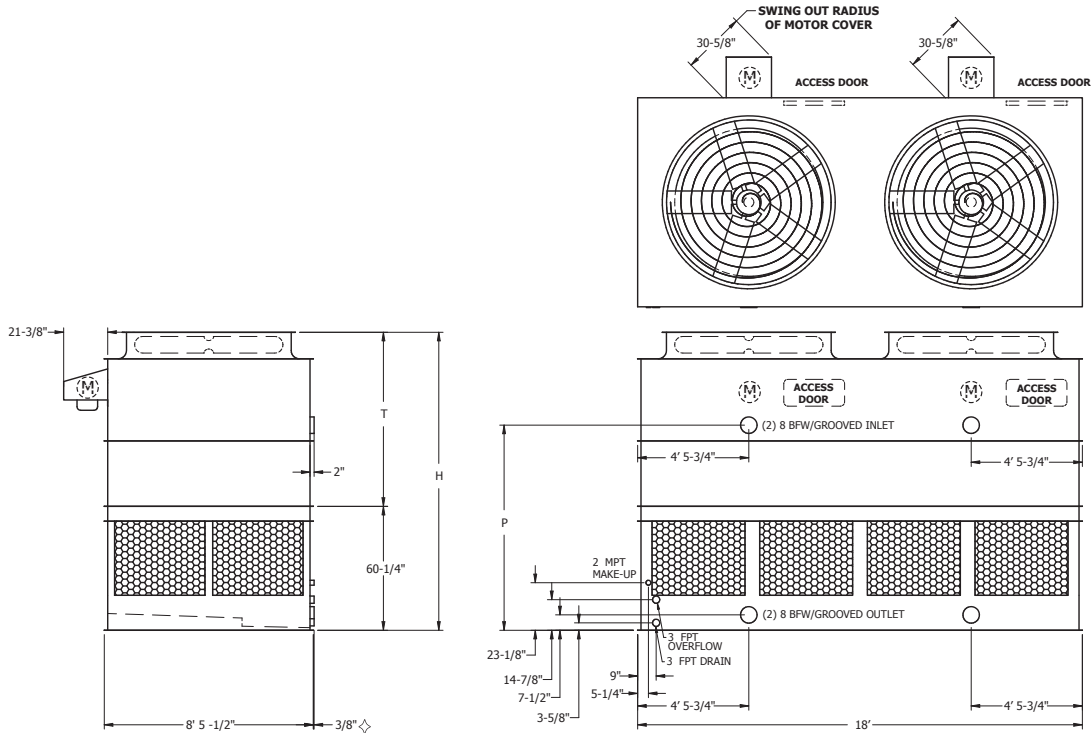

Model No.	Nominal Tonnage	WEIGHTS (LBS)			Fan Motor (HP)	Air Flow (CFM)	DIMENSIONS		
		Shipping	Operating	Heaviest Section [†]			H [†]	T [†]	P
AT 29-2G18	274	8,110	14,000	5,290	5	72,000	12' 3/4"	7' 1/2"	8' 3-1/2"
AT 29-2H18	329	8,190	14,080	5,370	7.5	81,900	12' 3/4"	7' 1/2"	8' 3-1/2"
AT 29-2I18	362	8,250	14,140	5,430	10	89,800	12' 3/4"	7' 1/2"	8' 3-1/2"
AT 29-2J18	422	8,390	14,280	5,570	15	102,000	12' 3/4"	7' 1/2"	8' 3-1/2"
AT 29-3G18	312	8,640	14,530	5,820	5	70,900	13' 3/4"	8' 1/2"	9' 3-1/2"
AT 29-3H18	368	8,720	14,610	5,900	7.5	80,600	13' 3/4"	8' 1/2"	9' 3-1/2"
AT 29-3I18	404	8,780	14,670	5,960	10	88,200	13' 3/4"	8' 1/2"	9' 3-1/2"
AT 29-3J18	471	8,920	14,810	6,100	15	100,000	13' 3/4"	8' 1/2"	9' 3-1/2"
AT 29-4G18	335	9,220	15,110	6,400	5	69,700	14' 3/4"	9' 1/2"	10' 3-1/2"
AT 29-4H18	387	9,300	15,190	6,480	7.5	79,300	14' 3/4"	9' 1/2"	10' 3-1/2"
AT 29-4I18	425	9,360	15,250	6,540	10	86,800	14' 3/4"	9' 1/2"	10' 3-1/2"
AT 29-4J18	491	9,500	15,390	6,680	15	98,400	14' 3/4"	9' 1/2"	10' 3-1/2"
AT 29-4K18	538	9,600	15,490	6,780	20	107,600	14' 3/4"	9' 1/2"	10' 3-1/2"
SLSF Addition		300	300	150			1' 9"	1' 9"	

- NOTE: (1) An adequately sized bleed line must be installed in the cooling tower system to prevent build-up of impurities in the recirculated water.
 (2) Do not use catalog drawings for certified prints. Dimensions and weights are subject to change.
 (3) Adequate spacing must be allowed for access to the cooling tower. Refer to EVAPCO's Equipment Layout Manual.
 (4) Nominal Tonnage is based on 3 gpm per ton at 95 degree entering water temperature, 85 degree leaving water temperature, and 78 degree wet-bulb temperature.

◇ Outlet connection extends beyond bottom flange.
 † Height includes fan guard which ships factory mounted.

◆ Heaviest section is upper section.

Models: AT/UT/USS 217-2G9 to 217-4K9

Two-Cell Cooling Towers

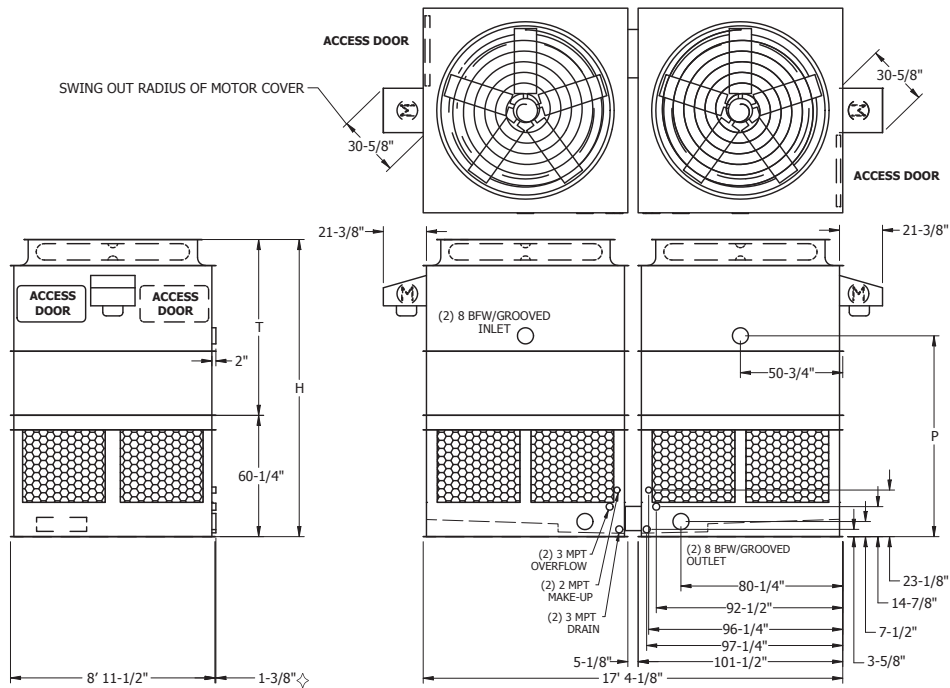

Model No.	Nominal Tonnage	WEIGHTS (LBS)			Fan Motor (HP)	Air Flow (CFM)	DIMENSIONS		
		Shipping	Operating	Heaviest Section†			H†	T†	P
AT 217-2G9	270	8,420	14,100	2,670	(2) 5	71,700	12' 3-3/8"	7' 3-1/8"	8' 6-1/8"
AT 217-2H9	324	8,500	14,180	2,710	(2) 7.5	81,500	12' 3-3/8"	7' 3-1/8"	8' 6-1/8"
AT 217-2I9	356	8,560	14,240	2,740	(2) 10	89,300	12' 3-3/8"	7' 3-1/8"	8' 6-1/8"
AT 217-2J9	416	8,700	14,380	2,810	(2) 15	101,500	12' 3-3/8"	7' 3-1/8"	8' 6-1/8"
AT 217-3G9	308	8,960	14,640	2,940	(2) 5	70,600	13' 3-3/8"	8' 3-1/8"	9' 6-1/8"
AT 217-3H9	362	9,040	14,720	2,980	(2) 7.5	80,200	13' 3-3/8"	8' 3-1/8"	9' 6-1/8"
AT 217-3I9	399	9,100	14,780	3,010	(2) 10	87,800	13' 3-3/8"	8' 3-1/8"	9' 6-1/8"
AT 217-3J9	464	9,240	14,920	3,080	(2) 15	99,500	13' 3-3/8"	8' 3-1/8"	9' 6-1/8"
AT 217-4G9	330	9,580	15,260	3,250	(2) 5	69,400	14' 3-3/8"	9' 3-1/8"	10' 6-1/8"
AT 217-4H9	381	9,660	15,340	3,290	(2) 7.5	78,900	14' 3-3/8"	9' 3-1/8"	10' 6-1/8"
AT 217-4I9	418	9,720	15,400	3,320	(2) 10	86,400	14' 3-3/8"	9' 3-1/8"	10' 6-1/8"
AT 217-4J9	484	9,860	15,540	3,390	(2) 15	97,900	14' 3-3/8"	9' 3-1/8"	10' 6-1/8"
AT 217-4K9	530	9,960	15,640	3,440	(2) 20	107,100	14' 3-3/8"	9' 3-1/8"	10' 6-1/8"
SLSF Addition		300	300	150			1' 9"	1' 9"	

- NOTE: (1) An adequately sized bleed line must be installed in the cooling tower system to prevent build-up of impurities in the recirculated water.
(2) Do not use catalog drawings for certified prints. Dimensions and weights are subject to change.
(3) Adequate spacing must be allowed for access to the cooling tower. Refer to EVAPCO's Equipment Layout Manual.
(4) Nominal Tonnage is based on 3 gpm per ton at 95 degree entering water temperature, 85 degree leaving water temperature, and 78 degree wet-bulb temperature.

◇ Outlet connection extends beyond bottom flange.
† Height includes fan guard which ships factory mounted.

◆ Heaviest section is upper section.

Models: AT/UT/USS 19-2G11 to 19-4L11

One-Cell Cooling Towers

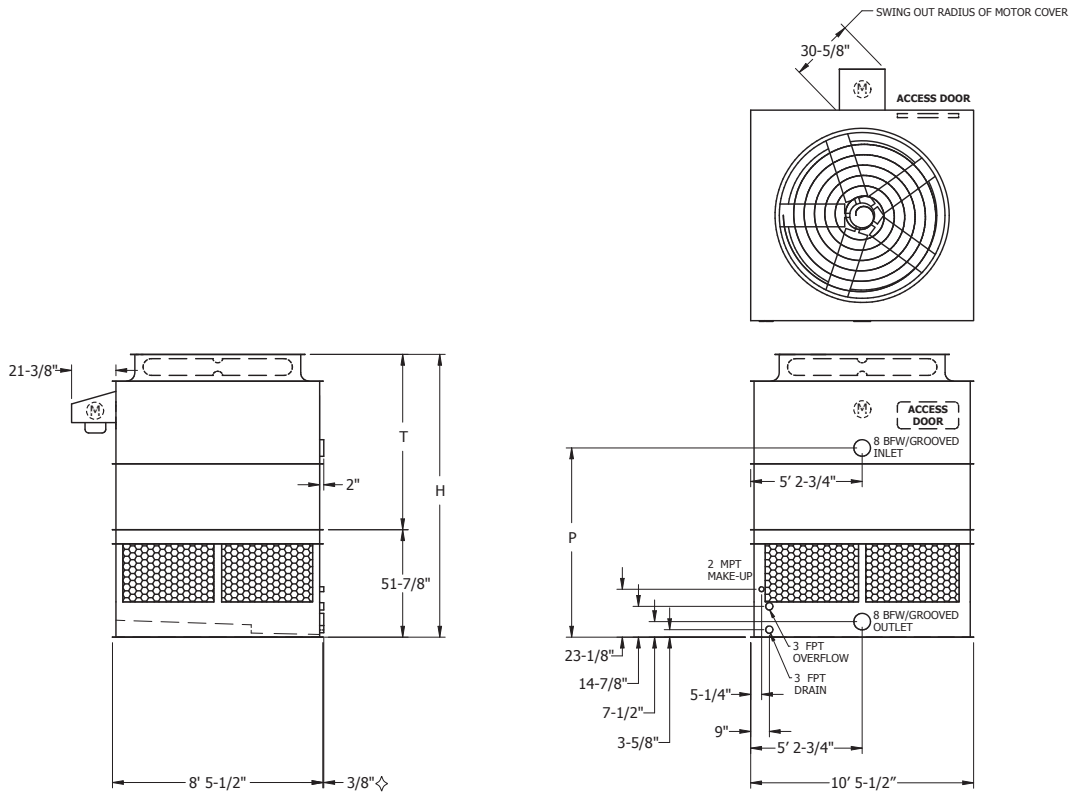

Model No.	Nominal Tonnage	WEIGHTS (LBS)			Fan Motor (HP)	Air Flow (CFM)	DIMENSIONS		
		Shipping	Operating	Heaviest Section [‡]			H [†]	T [†]	P
AT 19-2G11	156	4,660	7,960	3,060	5	40,200	11' 4-3/8"	7' 1/2"	7' 7-1/8"
AT 19-2H11	187	4,700	8,000	3,100	7.5	45,700	11' 4-3/8"	7' 1/2"	7' 7-1/8"
AT 19-2I11	202	4,730	8,030	3,130	10	50,200	11' 4-3/8"	7' 1/2"	7' 7-1/8"
AT 19-2J11	231	4,800	8,100	3,200	15	57,100	11' 4-3/8"	7' 1/2"	7' 7-1/8"
AT 19-3G11	172	4,980	8,280	3,380	5	39,700	12' 4-3/8"	8' 1/2"	8' 7-1/8"
AT 19-3H11	202	5,020	8,320	3,420	7.5	45,100	12' 4-3/8"	8' 1/2"	8' 7-1/8"
AT 19-3I11	221	5,050	8,350	3,450	10	49,400	12' 4-3/8"	8' 1/2"	8' 7-1/8"
AT 19-3J11	256	5,120	8,420	3,520	15	56,100	12' 4-3/8"	8' 1/2"	8' 7-1/8"
AT 19-3K11	285	5,170	8,470	3,570	20	61,300	12' 4-3/8"	8' 1/2"	8' 7-1/8"
AT 19-4G11	190	5,330	8,630	3,730	5	39,000	13' 4-3/8"	9' 1/2"	9' 7-1/8"
AT 19-4H11	220	5,370	8,670	3,770	7.5	44,300	13' 4-3/8"	9' 1/2"	9' 7-1/8"
AT 19-4I11	238	5,400	8,700	3,800	10	48,600	13' 4-3/8"	9' 1/2"	9' 7-1/8"
AT 19-4J11	270	5,470	8,770	3,870	15	55,100	13' 4-3/8"	9' 1/2"	9' 7-1/8"
AT 19-4K11	298	5,520	8,820	3,920	20	60,300	13' 4-3/8"	9' 1/2"	9' 7-1/8"
AT 19-4L11	314	5,550	8,850	3,950	25	64,600	13' 4-3/8"	9' 1/2"	9' 7-1/8"
SLSF Addition		150	150	150			1' 9"	1' 9"	

- NOTE: (1) An adequately sized bleed line must be installed in the cooling tower system to prevent build-up of impurities in the recirculated water.
 (2) Do not use catalog drawings for certified prints. Dimensions and weights are subject to change.
 (3) Adequate spacing must be allowed for access to the cooling tower. Refer to EVAPCO's Equipment Layout Manual.
 (4) Nominal Tonnage is based on 3 gpm per ton at 95 degree entering water temperature, 85 degree leaving water temperature, and 78 degree wet-bulb temperature.

◇ Outlet connection extends beyond bottom flange.
 † Height includes fan guard which ships factory mounted.

‡ Heaviest section is upper section.

Models: AT/UT/USS 29-2G21 to 29-4L21

Two-Cell Cooling Towers

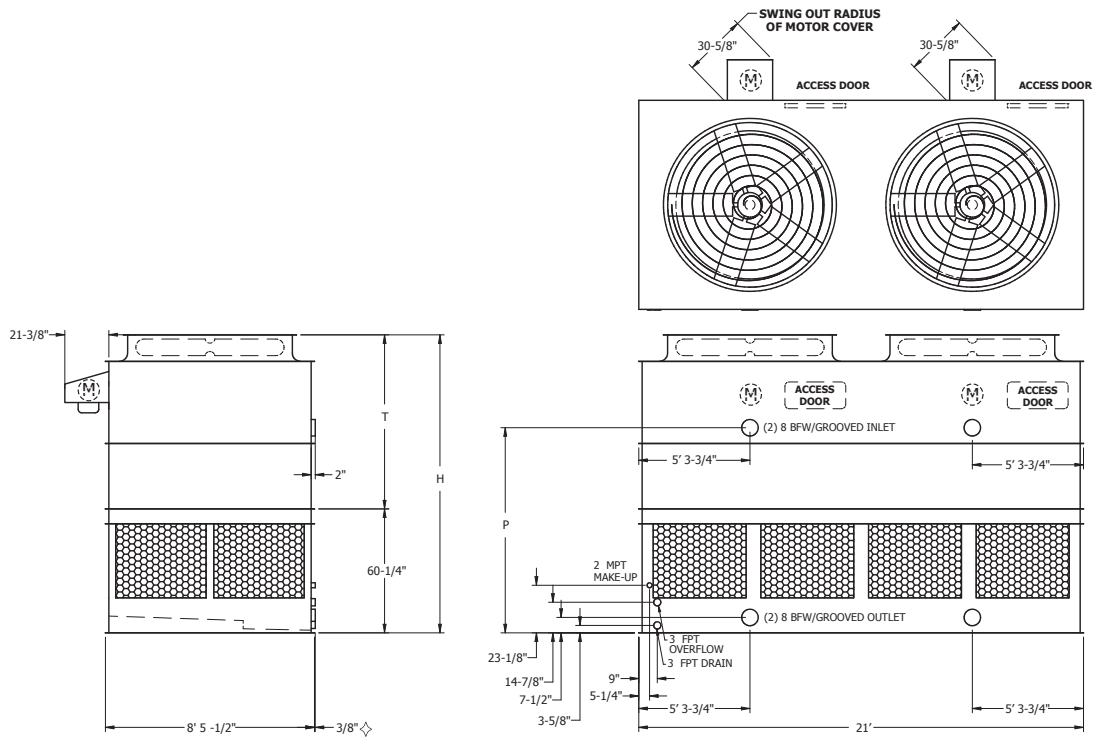

Model No.	Nominal Tonnage	WEIGHTS (LBS)			Fan Motor (HP)	Air Flow (CFM)	DIMENSIONS		
		Shipping	Operating	Heaviest Section†			H†	T†	P
AT 29-2G21	315	9,320	16,260	6,130	(2) 5	80,700	12' 3/4"	7' 1/2"	8' 3-1/2"
AT 29-2H21	379	9,400	16,340	6,210	(2) 7.5	91,800	12' 3/4"	7' 1/2"	8' 3-1/2"
AT 29-2I21	408	9,460	16,400	6,270	(2) 10	100,700	12' 3/4"	7' 1/2"	8' 3-1/2"
AT 29-2J21	467	9,600	16,540	6,410	(2) 15	114,600	12' 3/4"	7' 1/2"	8' 3-1/2"
AT 29-3G21	347	9,930	16,870	6,740	(2) 5	79,600	13' 3/4"	8' 1/2"	9' 3-1/2"
AT 29-3H21	410	10,010	16,950	6,820	(2) 7.5	90,500	13' 3/4"	8' 1/2"	9' 3-1/2"
AT 29-3I21	448	10,070	17,010	6,880	(2) 10	99,100	13' 3/4"	8' 1/2"	9' 3-1/2"
AT 29-3J21	518	10,210	17,150	7,020	(2) 15	112,500	13' 3/4"	8' 1/2"	9' 3-1/2"
AT 29-3K21	578	10,310	17,250	7,120	(2) 20	123,000	13' 3/4"	8' 1/2"	9' 3-1/2"
AT 29-4G21	383	10,590	17,530	7,400	(2) 5	78,200	14' 3/4"	9' 1/2"	10' 3-1/2"
AT 29-4H21	445	10,670	17,610	7,480	(2) 7.5	88,900	14' 3/4"	9' 1/2"	10' 3-1/2"
AT 29-4I21	482	10,730	17,670	7,540	(2) 10	97,400	14' 3/4"	9' 1/2"	10' 3-1/2"
AT 29-4J21	547	10,870	17,810	7,680	(2) 15	110,600	14' 3/4"	9' 1/2"	10' 3-1/2"
AT 29-4K21	604	10,970	17,910	7,780	(2) 20	120,900	14' 3/4"	9' 1/2"	10' 3-1/2"
AT 29-4L21	636	11,030	17,970	7,840	(2) 25	129,700	14' 3/4"	9' 1/2"	10' 3-1/2"
SLSF Addition		300	300	150			1' 9"	1' 9"	

- NOTE: (1) An adequately sized bleed line must be installed in the cooling tower system to prevent build-up of impurities in the recirculated water.
 (2) Do not use catalog drawings for certified prints. Dimensions and weights are subject to change.
 (3) Adequate spacing must be allowed for access to the cooling tower. Refer to EVAPCO's Equipment Layout Manual.
 (4) Nominal Tonnage is based on 3 gpm per ton at 95 degree entering water temperature, 85 degree leaving water temperature, and 78 degree wet-bulb temperature.

◇ Outlet connection extends beyond bottom flange.
 † Height includes fan guard which ships factory mounted.

◆ Heaviest section is upper section.

Models: AT/UT/USS 217-2G11 to 217-4L11

Two-Cell Cooling Towers

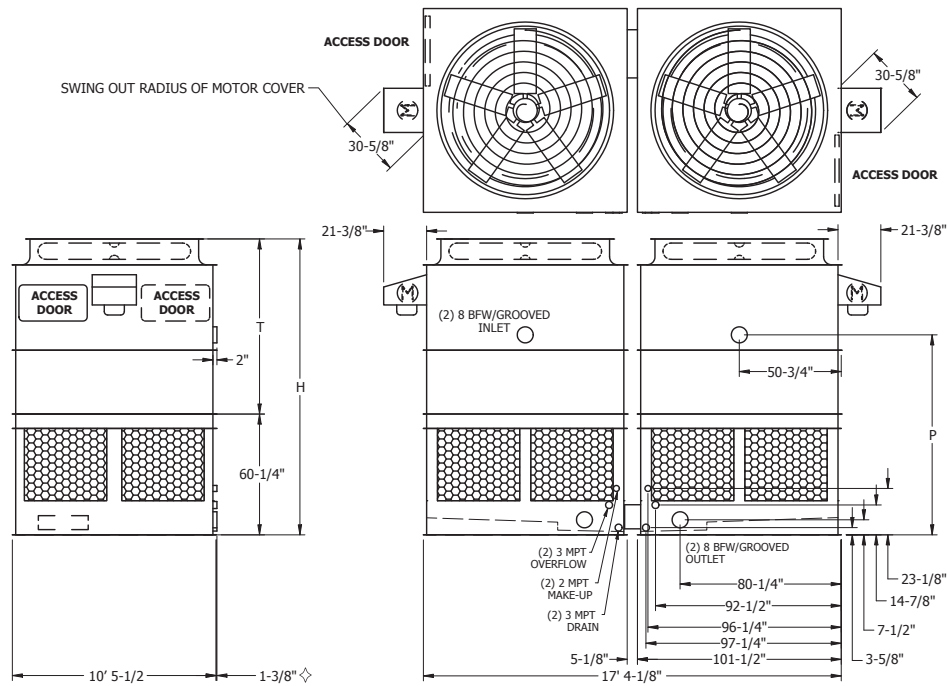

Model No.	Nominal Tonnage	WEIGHTS (LBS)			Fan Motor (HP)	Air Flow (CFM)	DIMENSIONS		
		Shipping	Operating	Heaviest Section†			H†	T†	P
AT 217-2G11	316	9,560	16,160	3,060	(2) 5	80,700	12' 3-3/8"	7' 3-1/8"	8' 6-1/8"
AT 217-2H11	379	9,640	16,240	3,100	(2) 7.5	91,800	12' 3-3/8"	7' 3-1/8"	8' 6-1/8"
AT 217-2I11	408	9,700	16,300	3,130	(2) 10	100,700	12' 3-3/8"	7' 3-1/8"	8' 6-1/8"
AT 217-2J11	467	9,840	16,440	3,200	(2) 15	114,600	12' 3-3/8"	7' 3-1/8"	8' 6-1/8"
AT 217-3G11	347	10,200	16,800	3,380	(2) 5	79,600	13' 3-3/8"	8' 3-1/8"	9' 6-1/8"
AT 217-3H11	409	10,280	16,880	3,420	(2) 7.5	90,500	13' 3-3/8"	8' 3-1/8"	9' 6-1/8"
AT 217-3I11	447	10,340	16,940	3,450	(2) 10	99,100	13' 3-3/8"	8' 3-1/8"	9' 6-1/8"
AT 217-3J11	516	10,480	17,080	3,520	(2) 15	112,500	13' 3-3/8"	8' 3-1/8"	9' 6-1/8"
AT 217-3K11	576	10,580	17,180	3,570	(2) 20	123,000	13' 3-3/8"	8' 3-1/8"	9' 6-1/8"
AT 217-4G11	385	10,900	17,500	3,730	(2) 5	78,200	14' 3-3/8"	9' 3-1/8"	10' 6-1/8"
AT 217-4H11	444	10,980	17,580	3,770	(2) 7.5	88,900	14' 3-3/8"	9' 3-1/8"	10' 6-1/8"
AT 217-4I11	480	11,040	17,640	3,800	(2) 10	97,400	14' 3-3/8"	9' 3-1/8"	10' 6-1/8"
AT 217-4J11	545	11,180	17,780	3,870	(2) 15	110,600	14' 3-3/8"	9' 3-1/8"	10' 6-1/8"
AT 217-4K11	602	11,280	17,880	3,920	(2) 20	120,900	14' 3-3/8"	9' 3-1/8"	10' 6-1/8"
AT 217-4L11	634	11,340	17,940	3,950	(2) 25	129,700	14' 3-3/8"	9' 3-1/8"	10' 6-1/8"
SLSF Addition		300	300	150			1' 9"	1' 9"	

- NOTE: (1) An adequately sized bleed line must be installed in the cooling tower system to prevent build-up of impurities in the recirculated water.
(2) Do not use catalog drawings for certified prints. Dimensions and weights are subject to change.
(3) Adequate spacing must be allowed for access to the cooling tower. Refer to EVAPCO's Equipment Layout Manual.
(4) Nominal Tonnage is based on 3 gpm per ton at 95 degree entering water temperature, 85 degree leaving water temperature, and 78 degree wet-bulb temperature.

◇ Outlet connection extends beyond bottom flange.
† Height includes fan guard which ships factory mounted.

◆ Heaviest section is upper section.

Models: AT/UT/USS 19-2H12 to 19-4M12

One-Cell Cooling Towers

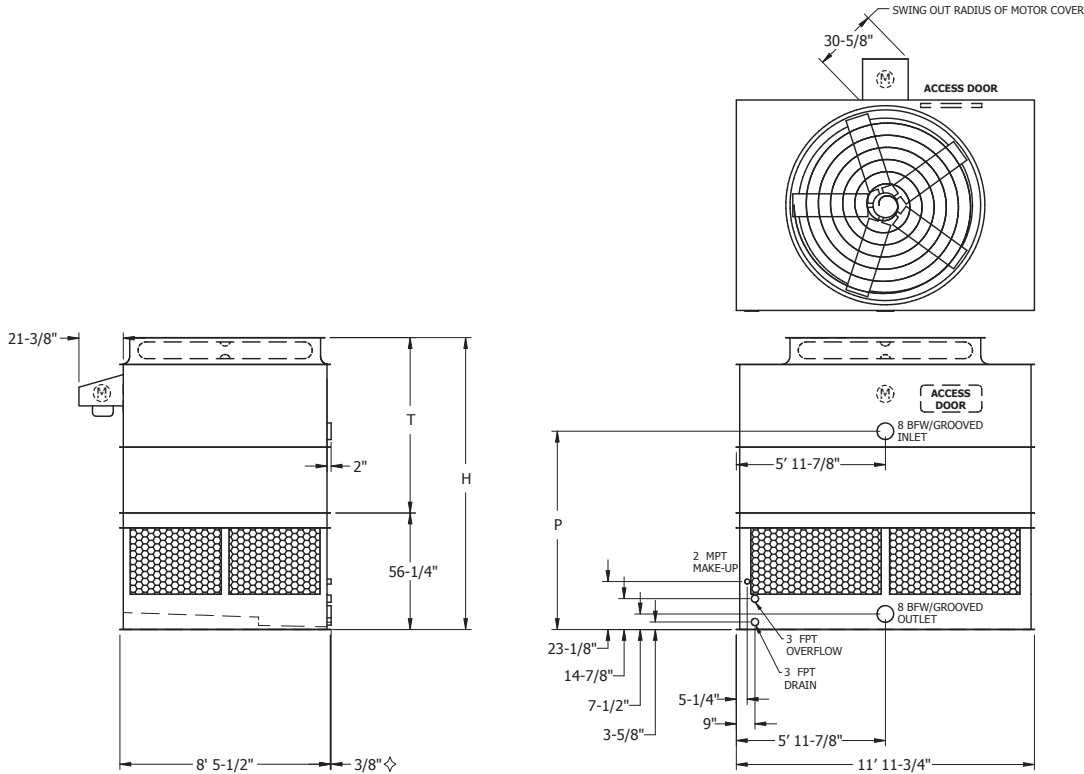

Model No.	Nominal Tonnage	WEIGHTS (LBS)			Fan Motor (HP)	Air Flow (CFM)	DIMENSIONS		
		Shipping	Operating	Heaviest Section†			H†	T†	P
AT 19-2H12	203	5,190	9,050	3,430	7.5	50,600	11' 8-3/4"	7' 1/2"	7' 11-1/2"
AT 19-2I12	230	5,220	9,080	3,460	10	55,400	11' 8-3/4"	7' 1/2"	7' 11-1/2"
AT 19-2J12	257	5,300	9,160	3,540	15	63,100	11' 8-3/4"	7' 1/2"	7' 11-1/2"
AT 19-2K12	283	5,340	9,200	3,580	20	69,100	11' 8-3/4"	7' 1/2"	7' 11-1/2"
AT 19-3H12	229	5,550	9,410	3,790	7.5	49,800	12' 8-3/4"	8' 1/2"	8' 11-1/2"
AT 19-3I12	256	5,580	9,440	3,820	10	54,500	12' 8-3/4"	8' 1/2"	8' 11-1/2"
AT 19-3J12	289	5,660	9,520	3,900	15	61,900	12' 8-3/4"	8' 1/2"	8' 11-1/2"
AT 19-3K12	319	5,700	9,560	3,940	20	67,800	12' 8-3/4"	8' 1/2"	8' 11-1/2"
AT 19-3L12	340	5,720	9,580	3,960	25	72,800	12' 8-3/4"	8' 1/2"	8' 11-1/2"
AT 19-4H12	243	5,940	9,800	4,180	7.5	49,000	13' 8-3/4"	9' 1/2"	9' 11-1/2"
AT 19-4I12	268	5,970	9,830	4,210	10	53,600	13' 8-3/4"	9' 1/2"	9' 11-1/2"
AT 19-4J12	299	6,050	9,910	4,290	15	61,000	13' 8-3/4"	9' 1/2"	9' 11-1/2"
AT 19-4K12	330	6,090	9,950	4,330	20	66,700	13' 8-3/4"	9' 1/2"	9' 11-1/2"
AT 19-4L12	352	6,110	9,970	4,350	25	71,500	13' 8-3/4"	9' 1/2"	9' 11-1/2"
AT 19-4M12	363	6,130	9,990	4,370	30	75,800	13' 8-3/4"	9' 1/2"	9' 11-1/2"
SLSF Addition		150	150	150			1' 9"	1' 9"	

- NOTE: (1) An adequately sized bleed line must be installed in the cooling tower system to prevent build-up of impurities in the recirculated water.
 (2) Do not use catalog drawings for certified prints. Dimensions and weights are subject to change.
 (3) Adequate spacing must be allowed for access to the cooling tower. Refer to EVAPCO's Equipment Layout Manual.
 (4) Nominal Tonnage is based on 3 gpm per ton at 95 degree entering water temperature, 85 degree leaving water temperature, and 78 degree wet-bulb temperature.

◇ Outlet connection extends beyond bottom flange.
 † Height includes fan guard which ships factory mounted.

◆ Heaviest section is upper section.

Models: AT/UT/USS 217-2H12 to 217-4M12

Two-Cell Cooling Towers

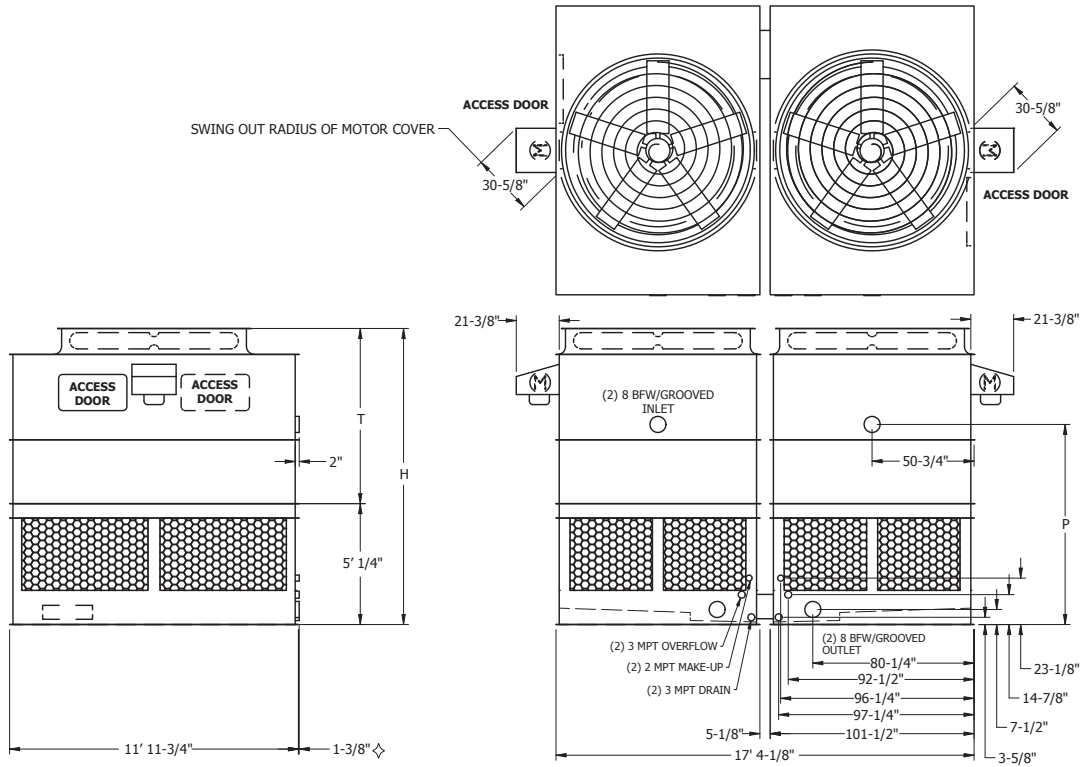

Model No.	Nominal Tonnage	WEIGHTS (LBS)			Fan Motor (HP)	Air Flow (CFM)	DIMENSIONS		
		Shipping	Operating	Heaviest Section [‡]			H [†]	T [†]	P
AT 217-2H12	394	10,560	18,280	3,430	(2) 7.5	99,600	12' 3-3/8"	7' 3-1/8"	8' 6-1/8"
AT 217-2I12	447	10,620	18,340	3,460	(2) 10	109,100	12' 3-3/8"	7' 3-1/8"	8' 6-1/8"
AT 217-2J12	499	10,780	18,500	3,540	(2) 15	124,300	12' 3-3/8"	7' 3-1/8"	8' 6-1/8"
AT 217-2K12	550	10,860	18,580	3,580	(2) 20	136,200	12' 3-3/8"	7' 3-1/8"	8' 6-1/8"
AT 217-3H12	446	11,280	19,000	3,790	(2) 7.5	98,100	13' 3-3/8"	8' 3-1/8"	9' 6-1/8"
AT 217-3I12	499	11,340	19,060	3,820	(2) 10	107,300	13' 3-3/8"	8' 3-1/8"	9' 6-1/8"
AT 217-3J12	564	11,500	19,220	3,900	(2) 15	122,000	13' 3-3/8"	8' 3-1/8"	9' 6-1/8"
AT 217-3K12	622	11,580	19,300	3,940	(2) 20	133,500	13' 3-3/8"	8' 3-1/8"	9' 6-1/8"
AT 217-3L12	665	11,620	19,340	3,960	(2) 25	143,200	13' 3-3/8"	8' 3-1/8"	9' 6-1/8"
AT 217-4H12	474	12,060	19,780	4,180	(2) 7.5	96,500	14' 3-3/8"	9' 3-1/8"	10' 6-1/8"
AT 217-4I12	524	12,120	19,840	4,210	(2) 10	105,600	14' 3-3/8"	9' 3-1/8"	10' 6-1/8"
AT 217-4J12	585	12,280	20,000	4,290	(2) 15	120,100	14' 3-3/8"	9' 3-1/8"	10' 6-1/8"
AT 217-4K12	645	12,360	20,080	4,330	(2) 20	131,400	14' 3-3/8"	9' 3-1/8"	10' 6-1/8"
AT 217-4L12	688	12,400	20,120	4,350	(2) 25	140,800	14' 3-3/8"	9' 3-1/8"	10' 6-1/8"
AT 217-4M12	709	12,440	20,160	4,370	(2) 30	149,300	14' 3-3/8"	9' 3-1/8"	10' 6-1/8"
SLSF Addition		300	300	150			1' 9"	1' 9"	

- NOTE: (1) An adequately sized bleed line must be installed in the cooling tower system to prevent build-up of impurities in the recirculated water.
 (2) Do not use catalog drawings for certified prints. Dimensions and weights are subject to change.
 (3) Adequate spacing must be allowed for access to the cooling tower. Refer to EVAPCO's Equipment Layout Manual.
 (4) Nominal Tonnage is based on 3 gpm per ton at 95 degree entering water temperature, 85 degree leaving water temperature, and 78 degree wet-bulb temperature.

◇ Outlet connection extends beyond bottom flange.
 † Height includes fan guard which ships factory mounted.

‡ Heaviest section is upper section.

Models: AT/UT/USS 29-2H24 to 29-4M24

Two-Cell Cooling Towers

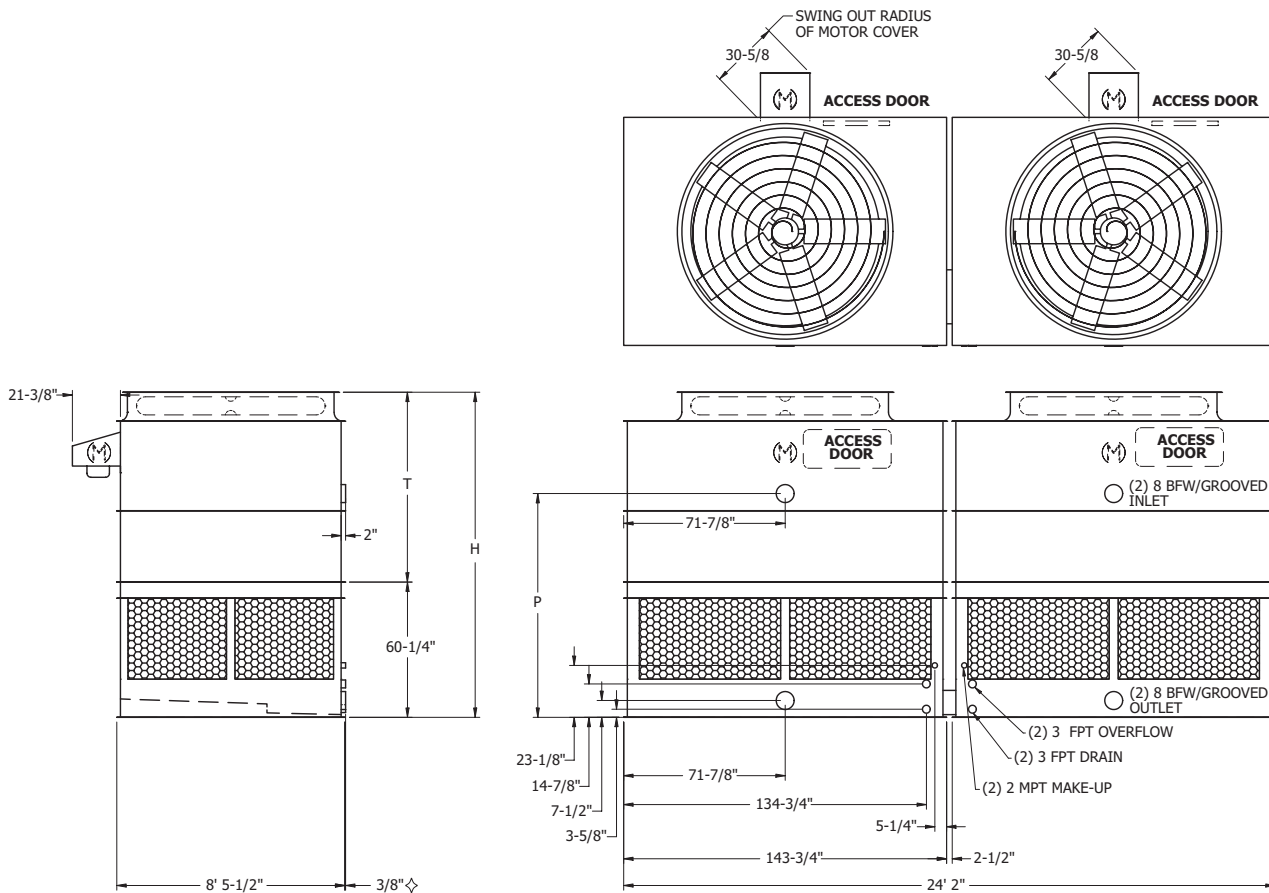

Model No.	Nominal Tonnage	WEIGHTS (LBS)			Fan Motor (HP)	Air Flow (CFM)	DIMENSIONS		
		Shipping	Operating	Heaviest Section†			H†	T†	P
AT 29-2H24	400	10,580	18,300	3,430	(2) 7.5	100,100	12' 3/4"	7' 1/2"	8' 3-1/2"
AT 29-2I24	454	10,640	18,360	3,460	(2) 10	109,700	12' 3/4"	7' 1/2"	8' 3-1/2"
AT 29-2J24	507	10,800	18,520	3,540	(2) 15	124,900	12' 3/4"	7' 1/2"	8' 3-1/2"
AT 29-2K24	559	10,880	18,600	3,580	(2) 20	136,800	12' 3/4"	7' 1/2"	8' 3-1/2"
AT 29-3H24	452	11,300	19,020	3,790	(2) 7.5	98,600	13' 3/4"	8' 1/2"	9' 3-1/2"
AT 29-3I24	506	11,360	19,080	3,820	(2) 10	107,900	13' 3/4"	8' 1/2"	9' 3-1/2"
AT 29-3J24	571	11,520	19,240	3,900	(2) 15	122,600	13' 3/4"	8' 1/2"	9' 3-1/2"
AT 29-3K24	630	11,600	19,320	3,940	(2) 20	134,100	13' 3/4"	8' 1/2"	9' 3-1/2"
AT 29-3L24	674	11,640	19,360	3,960	(2) 25	144,000	13' 3/4"	8' 1/2"	9' 3-1/2"
AT 29-4H24	481	12,080	19,800	4,180	(2) 7.5	96,900	14' 3/4"	9' 1/2"	10' 3-1/2"
AT 29-4I24	531	12,140	19,860	4,210	(2) 10	106,200	14' 3/4"	9' 1/2"	10' 3-1/2"
AT 29-4J24	593	12,300	20,020	4,290	(2) 15	120,700	14' 3/4"	9' 1/2"	10' 3-1/2"
AT 29-4K24	653	12,380	20,100	4,330	(2) 20	132,000	14' 3/4"	9' 1/2"	10' 3-1/2"
AT 29-4L24	696	12,420	20,140	4,350	(2) 25	141,500	14' 3/4"	9' 1/2"	10' 3-1/2"
AT 29-4M24	718	12,460	20,180	4,370	(2) 30	150,000	14' 3/4"	9' 1/2"	10' 3-1/2"
SLSF Addition		300	300	150			1' 9"	1' 9"	

- NOTE: (1) An adequately sized bleed line must be installed in the cooling tower system to prevent build-up of impurities in the recirculated water.
 (2) Do not use catalog drawings for certified prints. Dimensions and weights are subject to change.
 (3) Adequate spacing must be allowed for access to the cooling tower. Refer to EVAPCO's Equipment Layout Manual.
 (4) Nominal Tonnage is based on 3 gpm per ton at 95 degree entering water temperature, 85 degree leaving water temperature, and 78 degree wet-bulb temperature.

◇ Outlet connection extends beyond bottom flange.
 † Height includes fan guard which ships factory mounted.

◆ Heaviest section is upper section.

Models: AT/UT/USS 39-2H36 to 39-4M36

Three-Cell Cooling Towers

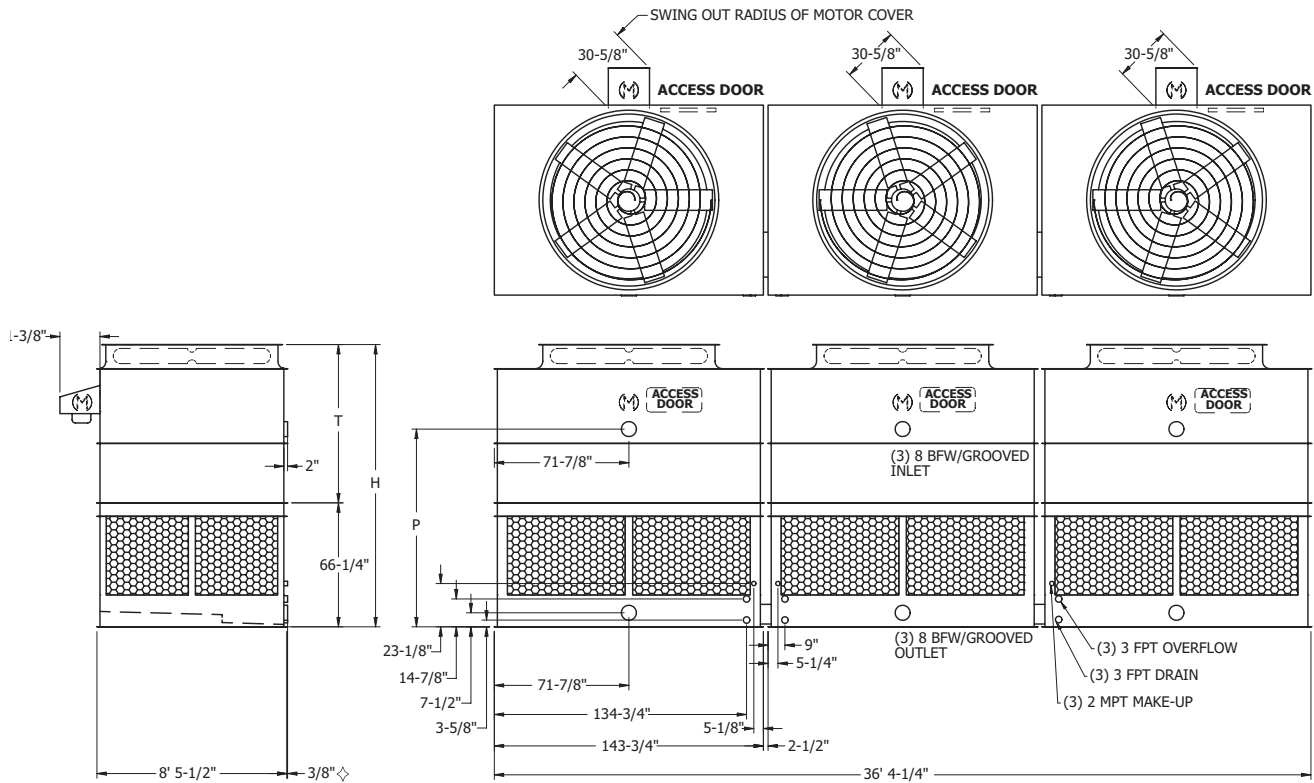

Model No.	Nominal Tonnage	WEIGHTS (LBS)			Fan Motor (HP)	Air Flow (CFM)	DIMENSIONS		
		Shipping	Operating	Heaviest Section†			H†	T†	P
AT 39-2H36	605	15,990	27,570	3,430	(3) 7.5	150,900	12' 6-3/4"	7' 1/2"	8' 9-1/2"
AT 39-2I36	686	16,080	27,660	3,460	(3) 10	165,200	12' 6-3/4"	7' 1/2"	8' 9-1/2"
AT 39-2J36	765	16,320	27,900	3,540	(3) 15	188,200	12' 6-3/4"	7' 1/2"	8' 9-1/2"
AT 39-2K36	843	16,440	28,020	3,580	(3) 20	206,200	12' 6-3/4"	7' 1/2"	8' 9-1/2"
AT 39-3H36	682	17,070	28,650	3,790	(3) 7.5	148,600	13' 6-3/4"	8' 1/2"	9' 9-1/2"
AT 39-3I36	763	17,160	28,740	3,820	(3) 10	162,500	13' 6-3/4"	8' 1/2"	9' 9-1/2"
AT 39-3J36	862	17,400	28,980	3,900	(3) 15	184,700	13' 6-3/4"	8' 1/2"	9' 9-1/2"
AT 39-3K36	951	17,520	29,100	3,940	(3) 20	202,100	13' 6-3/4"	8' 1/2"	9' 9-1/2"
AT 39-3L36	1,016	17,580	29,160	3,960	(3) 25	217,000	13' 6-3/4"	8' 1/2"	9' 9-1/2"
AT 39-4H36	725	18,240	29,820	4,180	(3) 7.5	146,100	14' 6-3/4"	9' 1/2"	10' 9-1/2"
AT 39-4I36	800	18,330	29,910	4,210	(3) 10	159,900	14' 6-3/4"	9' 1/2"	10' 9-1/2"
AT 39-4J36	893	18,570	30,150	4,290	(3) 15	181,900	14' 6-3/4"	9' 1/2"	10' 9-1/2"
AT 39-4K36	984	18,690	30,270	4,330	(3) 20	198,900	14' 6-3/4"	9' 1/2"	10' 9-1/2"
AT 39-4L36	1,050	18,750	30,330	4,350	(3) 25	213,200	14' 6-3/4"	9' 1/2"	10' 9-1/2"
AT 39-4M36	1,082	18,810	30,390	4,370	(3) 30	226,000	14' 6-3/4"	9' 1/2"	10' 9-1/2"
SLSF Addition		450	450	150			1' 9"	1' 9"	

- NOTE: (1) An adequately sized bleed line must be installed in the cooling tower system to prevent build-up of impurities in the recirculated water.
 (2) Do not use catalog drawings for certified prints. Dimensions and weights are subject to change.
 (3) Adequate spacing must be allowed for access to the cooling tower. Refer to EVAPCO's Equipment Layout Manual.
 (4) Nominal Tonnage is based on 3 gpm per ton at 95 degree entering water temperature, 85 degree leaving water temperature, and 78 degree wet-bulb temperature.

◇ Outlet connection extends beyond bottom flange.
 † Height includes fan guard which ships factory mounted.

◆ Heaviest section is upper section.

Models: AT/UT/USS 19-2H14 to 19-4M14

One-Cell Cooling Towers

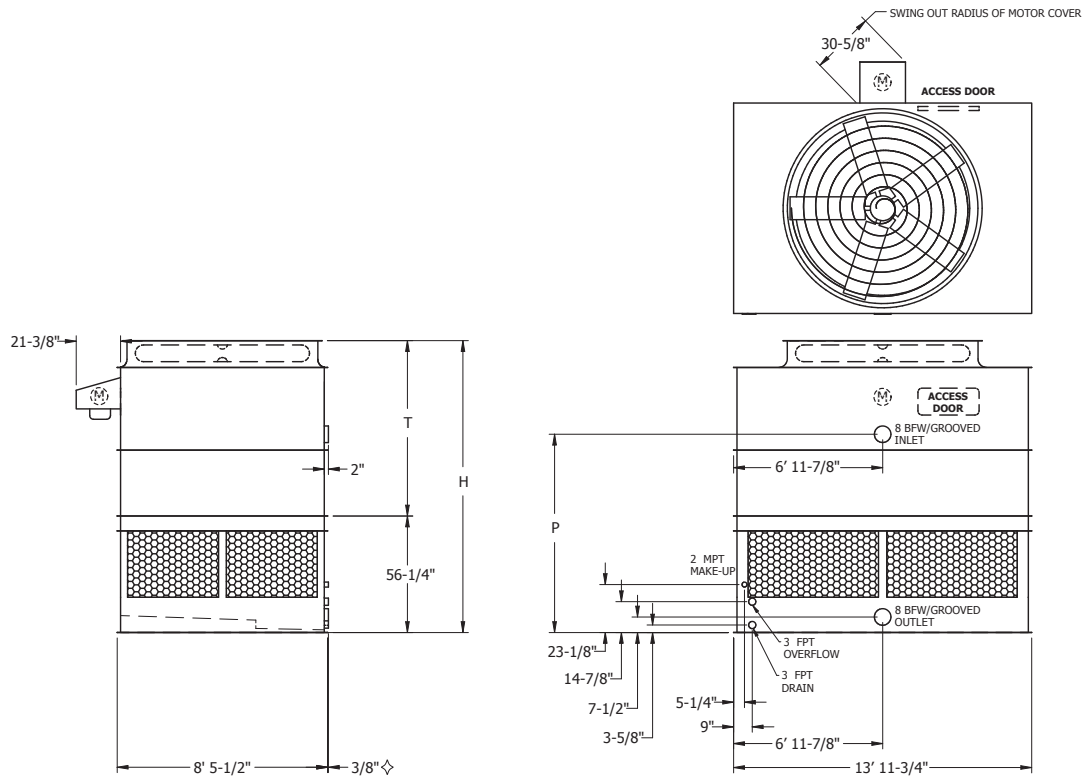

Model No.	Nominal Tonnage	WEIGHTS (LBS)			Fan Motor (HP)	Air Flow (CFM)	DIMENSIONS		
		Shipping	Operating	Heaviest Section [‡]			H [†]	T [†]	P
AT 19-2H14	221	5,730	10,240	3,680	7.5	55,900	11' 8-3/4"	7' 1/2"	7' 11-1/2"
AT 19-2I14	251	5,760	10,270	3,710	10	61,300	11' 8-3/4"	7' 1/2"	7' 11-1/2"
AT 19-2J14	280	5,840	10,350	3,790	15	69,800	11' 8 3/4"	7' 1/2"	7' 11-1/2"
AT 19-2K14	309	5,880	10,390	3,830	20	76,500	11' 8 3/4"	7' 1/2"	7' 11-1/2"
AT 19-2L14	337	5,900	10,410	3,850	25	82,000	11' 8 3/4"	7' 1/2"	7' 11-1/2"
AT 19-3H14	249	6,140	10,650	4,090	7.5	55,100	12' 8-3/4"	8' 1/2"	8' 11-1/2"
AT 19-3I14	280	6,170	10,680	4,120	10	60,300	12' 8-3/4"	8' 1/2"	8' 11-1/2"
AT 19-3J14	315	6,250	10,760	4,200	15	68,600	12' 8-3/4"	8' 1/2"	8' 11-1/2"
AT 19-3K14	347	6,290	10,800	4,240	20	75,000	12' 8-3/4"	8' 1/2"	8' 11-1/2"
AT 19-3L14	377	6,310	10,820	4,260	25	80,400	12' 8-3/4"	8' 1/2"	8' 11-1/2"
AT 19-3M14	399	6,330	10,840	4,280	30	85,200	12' 8-3/4"	8' 1/2"	8' 11-1/2"
AT 19-4H14	266	6,590	11,100	4,540	7.5	54,200	13' 8-3/4"	9' 1/2"	9' 11-1/2"
AT 19-4I14	295	6,620	11,130	4,570	10	59,300	13' 8-3/4"	9' 1/2"	9' 11-1/2"
AT 19-4J14	329	6,700	11,210	4,650	15	67,500	13' 8-3/4"	9' 1/2"	9' 11-1/2"
AT 19-4K14	361	6,740	11,250	4,690	20	73,800	13' 8 3/4"	9' 1/2"	9' 11-1/2"
AT 19-4L14	391	6,760	11,270	4,710	25	79,100	13' 8 3/4"	9' 1/2"	9' 11-1/2"
AT 19-4M14	413	6,780	11,290	4,730	30	83,700	13' 8 3/4"	9' 1/2"	9' 11-1/2"
SLSF Addition		150	150	150			1' 9"	1' 9"	

- NOTE: (1) An adequately sized bleed line must be installed in the cooling tower system to prevent build-up of impurities in the recirculated water.
 (2) Do not use catalog drawings for certified prints. Dimensions and weights are subject to change.
 (3) Adequate spacing must be allowed for access to the cooling tower. Refer to EVAPCO's Equipment Layout Manual.
 (4) Nominal Tonnage is based on 3 gpm per ton at 95 degree entering water temperature, 85 degree leaving water temperature, and 78 degree wet-bulb temperature.

◇ Outlet connection extends beyond bottom flange.
 † Height includes fan guard which ships factory mounted.

‡ Heaviest section is upper section.

Models: AT/UT/USS 217-2H14 to 217-4M14

Two-Cell Cooling Towers

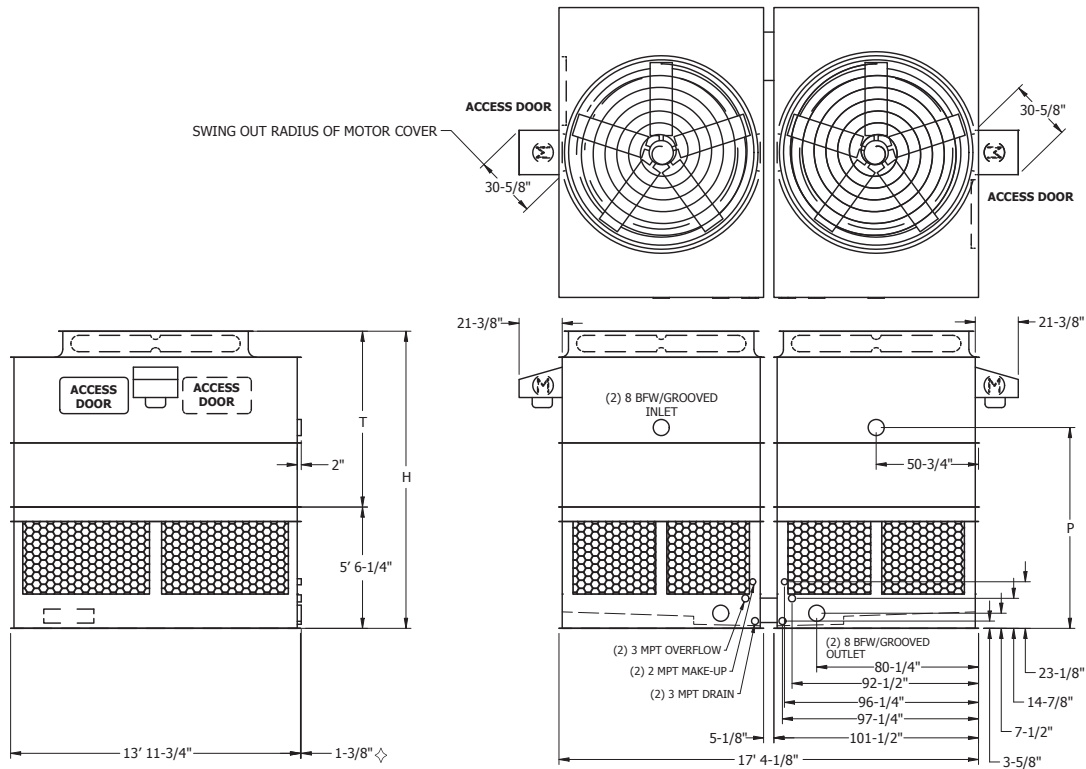

Model No.	Nominal Tonnage	WEIGHTS (LBS)			Fan Motor (HP)	Air Flow (CFM)	DIMENSIONS		
		Shipping	Operating	Heaviest Section†			H†	T†	P
AT 217-2H14	435	11,640	20,660	3,680	(2) 7.5	112,300	12' 9-3/8"	7' 3-1/8"	9' 1/8"
AT 217-2I14	494	11,700	20,720	3,710	(2) 10	123,000	12' 9-3/8"	7' 3-1/8"	9' 1/8"
AT 217-2J14	551	11,860	20,880	3,790	(2) 15	140,200	12' 9-3/8"	7' 3-1/8"	9' 1/8"
AT 217-2K14	608	11,940	20,960	3,830	(2) 20	153,600	12' 9-3/8"	7' 3-1/8"	9' 1/8"
AT 217-2L14	664	11,980	21,000	3,850	(2) 25	164,700	12' 9-3/8"	7' 3-1/8"	9' 1/8"
AT 217-3H14	490	12,460	21,480	4,090	(2) 7.5	110,600	13' 9-3/8"	8' 3-1/8"	10' 1/8"
AT 217-3I14	551	12,520	21,540	4,120	(2) 10	121,100	13' 9-3/8"	8' 3-1/8"	10' 1/8"
AT 217-3J14	621	12,680	21,700	4,200	(2) 15	137,700	13' 9-3/8"	8' 3-1/8"	10' 1/8"
AT 217-3K14	685	12,760	21,780	4,240	(2) 20	150,600	13' 9-3/8"	8' 3-1/8"	10' 1/8"
AT 217-3L14	744	12,800	21,820	4,260	(2) 25	161,500	13' 9-3/8"	8' 3-1/8"	10' 1/8"
AT 217-3M14	787	12,840	21,860	4,280	(2) 30	171,100	13' 9-3/8"	8' 3-1/8"	10' 1/8"
AT 217-4H14	525	13,360	22,380	4,540	(2) 7.5	108,800	14' 9-3/8"	9' 3-1/8"	11' 1/8"
AT 217-4I14	581	13,420	22,440	4,570	(2) 10	119,100	14' 9-3/8"	9' 3-1/8"	11' 1/8"
AT 217-4J14	649	13,580	22,600	4,650	(2) 15	135,500	14' 9-3/8"	9' 3-1/8"	11' 1/8"
AT 217-4K14	714	13,660	22,680	4,690	(2) 20	148,300	14' 9-3/8"	9' 3-1/8"	11' 1/8"
AT 217-4L14	773	13,700	22,720	4,710	(2) 25	158,900	14' 9-3/8"	9' 3-1/8"	11' 1/8"
AT 217-4M14	815	13,740	22,760	4,730	(2) 30	168,200	14' 9-3/8"	9' 3-1/8"	11' 1/8"
SLSF Addition		300	300	150			1' 9"	1' 9"	

- NOTE: (1) An adequately sized bleed line must be installed in the cooling tower system to prevent build-up of impurities in the recirculated water.
 (2) Do not use catalog drawings for certified prints. Dimensions and weights are subject to change.
 (3) Adequate spacing must be allowed for access to the cooling tower. Refer to EVAPCO's Equipment Layout Manual.
 (4) Nominal Tonnage is based on 3 gpm per ton at 95 degree entering water temperature, 85 degree leaving water temperature, and 78 degree wet-bulb temperature.

◇ Outlet connection extends beyond bottom flange.
 † Height includes fan guard which ships factory mounted.

◆ Heaviest section is upper section.

Models: AT/UT/USS 29-2H28 to 29-4M28

Two-Cell Cooling Towers

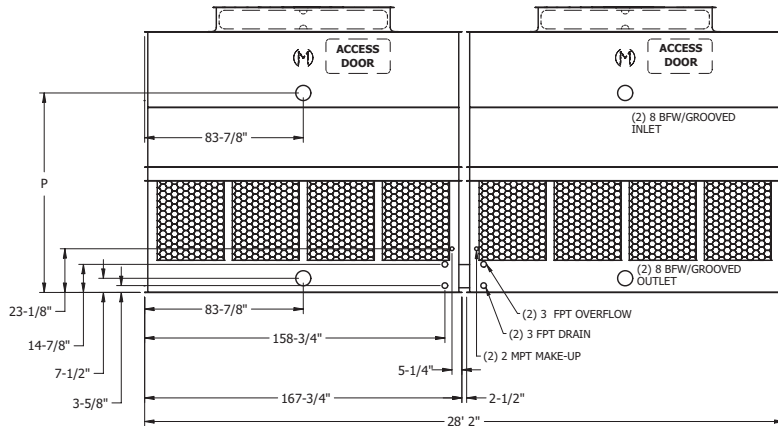
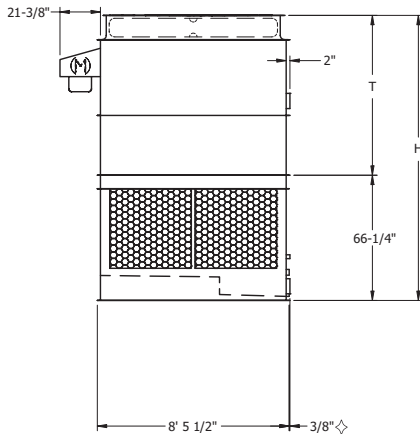
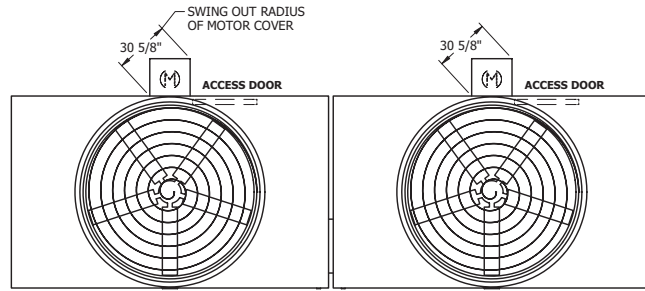

Model No.	Nominal Tonnage	WEIGHTS (LBS)			Fan Motor (HP)	Air Flow (CFM)	DIMENSIONS		
		Shipping	Operating	Heaviest Section†			H†	T†	P
AT 29-2H28	446	11,640	20,660	3,680	(2) 7.5	112,300	12' 6-3/4"	7' 1/2"	8' 9-1/2"
AT 29-2I28	506	11,700	20,720	3,710	(2) 10	123,000	12' 6-3/4"	7' 1/2"	8' 9-1/2"
AT 29-2J28	563	11,860	20,880	3,790	(2) 15	140,200	12' 6-3/4"	7' 1/2"	8' 9-1/2"
AT 29-2K28	622	11,940	20,960	3,830	(2) 20	153,600	12' 6-3/4"	7' 1/2"	8' 9-1/2"
AT 29-2L28	678	11,980	21,000	3,850	(2) 25	164,700	12' 6-3/4"	7' 1/2"	8' 9-1/2"
AT 29-3H28	502	12,460	21,480	4,090	(2) 7.5	110,700	13' 6-3/4"	8' 1/2"	9' 9-1/2"
AT 29-3I28	563	12,520	21,540	4,120	(2) 10	121,100	13' 6-3/4"	8' 1/2"	9' 9-1/2"
AT 29-3J28	633	12,680	21,700	4,200	(2) 15	137,700	13' 6-3/4"	8' 1/2"	9' 9-1/2"
AT 29-3K28	698	12,760	21,780	4,240	(2) 20	150,600	13' 6-3/4"	8' 1/2"	9' 9-1/2"
AT 29-3L28	757	12,800	21,820	4,260	(2) 25	161,500	13' 6-3/4"	8' 1/2"	9' 9-1/2"
AT 29-3M28	802	12,840	21,860	4,280	(2) 30	171,200	13' 6-3/4"	8' 1/2"	9' 9-1/2"
AT 29-4H28	535	13,360	22,380	4,540	(2) 7.5	108,800	14' 6-3/4"	9' 1/2"	10' 9-1/2"
AT 29-4I28	592	13,420	22,440	4,570	(2) 10	119,200	14' 6-3/4"	9' 1/2"	10' 9-1/2"
AT 29-4J28	661	13,580	22,600	4,650	(2) 15	135,600	14' 6-3/4"	9' 1/2"	10' 9-1/2"
AT 29-4K28	726	13,660	22,680	4,690	(2) 20	148,300	14' 6-3/4"	9' 1/2"	10' 9-1/2"
AT 29-4L28	787	13,700	22,720	4,710	(2) 25	158,900	14' 6-3/4"	9' 1/2"	10' 9-1/2"
AT 29-4M28	830	13,740	22,760	4,730	(2) 30	168,100	14' 6-3/4"	9' 1/2"	10' 9-1/2"
SLSF Addition		300	300	150			1' 9"	1' 9"	

- NOTE: (1) An adequately sized bleed line must be installed in the cooling tower system to prevent build-up of impurities in the recirculated water.
 (2) Do not use catalog drawings for certified prints. Dimensions and weights are subject to change.
 (3) Adequate spacing must be allowed for access to the cooling tower. Refer to EVAPCO's Equipment Layout Manual.
 (4) Nominal Tonnage is based on 3 gpm per ton at 95 degree entering water temperature, 85 degree leaving water temperature, and 78 degree wet-bulb temperature.

◇ Outlet connection extends beyond bottom flange.
 † Height includes fan guard which ships factory mounted.

◆ Heaviest section is upper section.

Models: AT/UT/USS 39-2H42 to 39-4M42

Three-Cell Cooling Towers

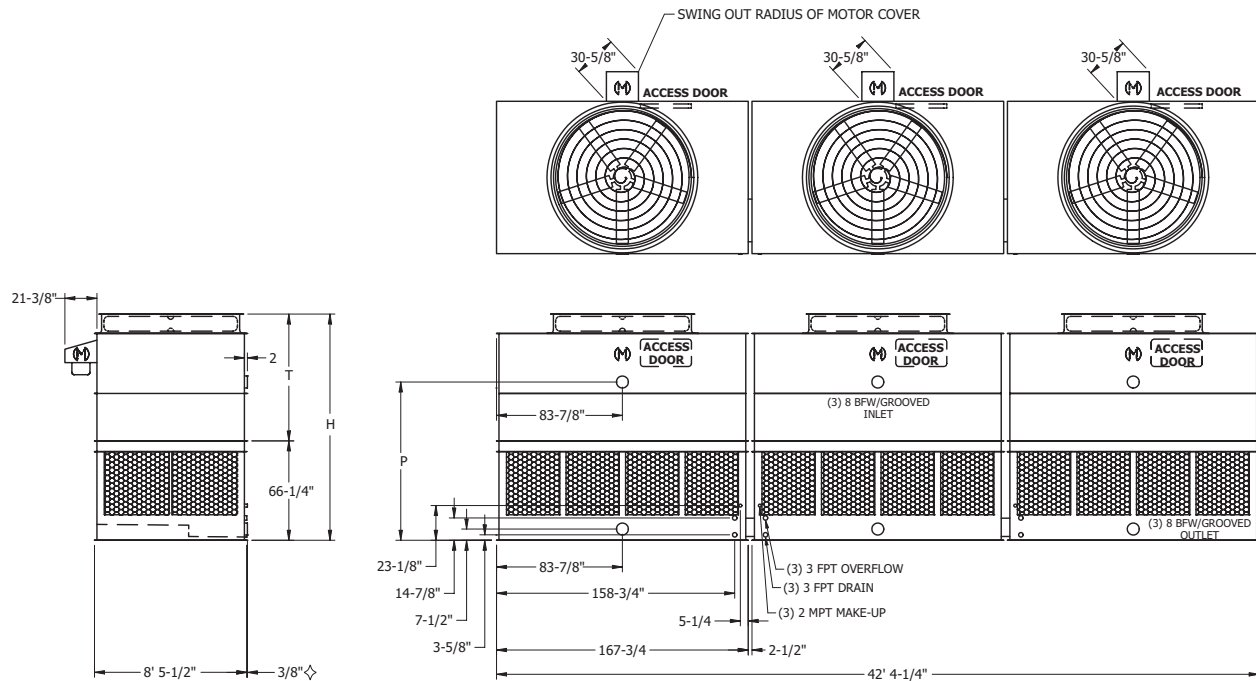

Model No.	Nominal Tonnage	WEIGHTS (LBS)			Fan Motor (HP)	Air Flow (CFM)	DIMENSIONS		
		Shipping	Operating	Heaviest Section†			H†	T†	P
AT 39-2H42	664	17,430	30,960	3,680	(3) 7.5	167,700	12' 6-3/4"	7' 6-3/4"	8' 9-1/2"
AT 39-2I42	754	17,520	31,050	3,710	(3) 10	183,700	12' 6-3/4"	7' 6-3/4"	8' 9-1/2"
AT 39-2J42	840	17,760	31,290	3,790	(3) 15	209,300	12' 6-3/4"	7' 6-3/4"	8' 9-1/2"
AT 39-2K42	927	17,880	31,410	3,830	(3) 20	229,300	12' 6-3/4"	7' 6-3/4"	8' 9-1/2"
AT 39-2L42	1,011	17,940	31,470	3,850	(3) 25	246,000	12' 6-3/4"	7' 6-3/4"	8' 9-1/2"
AT 39-3H42	748	18,660	32,190	4,090	(3) 7.5	165,200	13' 6-3/4"	8' 6-3/4"	9' 9-1/2"
AT 39-3I42	839	18,750	32,280	4,120	(3) 10	180,800	13' 6-3/4"	8' 6-3/4"	9' 9-1/2"
AT 39-3J42	945	18,990	32,520	4,200	(3) 15	205,600	13' 6-3/4"	8' 6-3/4"	9' 9-1/2"
AT 39-3K42	1,042	19,110	32,640	4,240	(3) 20	224,900	13' 6-3/4"	8' 6-3/4"	9' 9-1/2"
AT 39-3L42	1,130	19,170	32,700	4,260	(3) 25	241,200	13' 6-3/4"	8' 6-3/4"	9' 9-1/2"
AT 39-3M42	1,197	19,230	32,760	4,280	(3) 30	255,600	13' 6-3/4"	8' 6-3/4"	9' 9-1/2"
AT 39-4H42	799	20,010	33,540	4,540	(3) 7.5	162,400	14' 6-3/4"	9' 6-3/4"	10' 9-1/2"
AT 39-4I42	884	20,100	33,630	4,570	(3) 10	177,900	14' 6-3/4"	9' 6-3/4"	10' 9-1/2"
AT 39-4J42	986	20,340	33,870	4,650	(3) 15	202,400	14' 6-3/4"	9' 6-3/4"	10' 9-1/2"
AT 39-4K42	1,084	20,460	33,990	4,690	(3) 20	221,400	14' 6-3/4"	9' 6-3/4"	10' 9-1/2"
AT 39-4L42	1,174	20,520	34,050	4,710	(3) 25	237,200	14' 6-3/4"	9' 6-3/4"	10' 9-1/2"
AT 39-4M42	1,239	20,580	34,110	4,730	(3) 30	251,100	14' 6-3/4"	9' 6-3/4"	10' 9-1/2"
SLSF Addition		450	450	150			1' 9"	1' 9"	

- NOTE: (1) An adequately sized bleed line must be installed in the cooling tower system to prevent build-up of impurities in the recirculated water.
 (2) Do not use catalog drawings for certified prints. Dimensions and weights are subject to change.
 (3) Adequate spacing must be allowed for access to the cooling tower. Refer to EVAPCO's Equipment Layout Manual.
 (4) Nominal Tonnage is based on 3 gpm per ton at 95 degree entering water temperature, 85 degree leaving water temperature, and 78 degree wet-bulb temperature.

◇ Outlet connection extends beyond bottom flange.
 † Height includes fan guard which ships factory mounted.

◆ Heaviest section is upper section.

Models: AT/UT/USS 110-2I12 to 110-4N12

One-Cell Cooling Towers

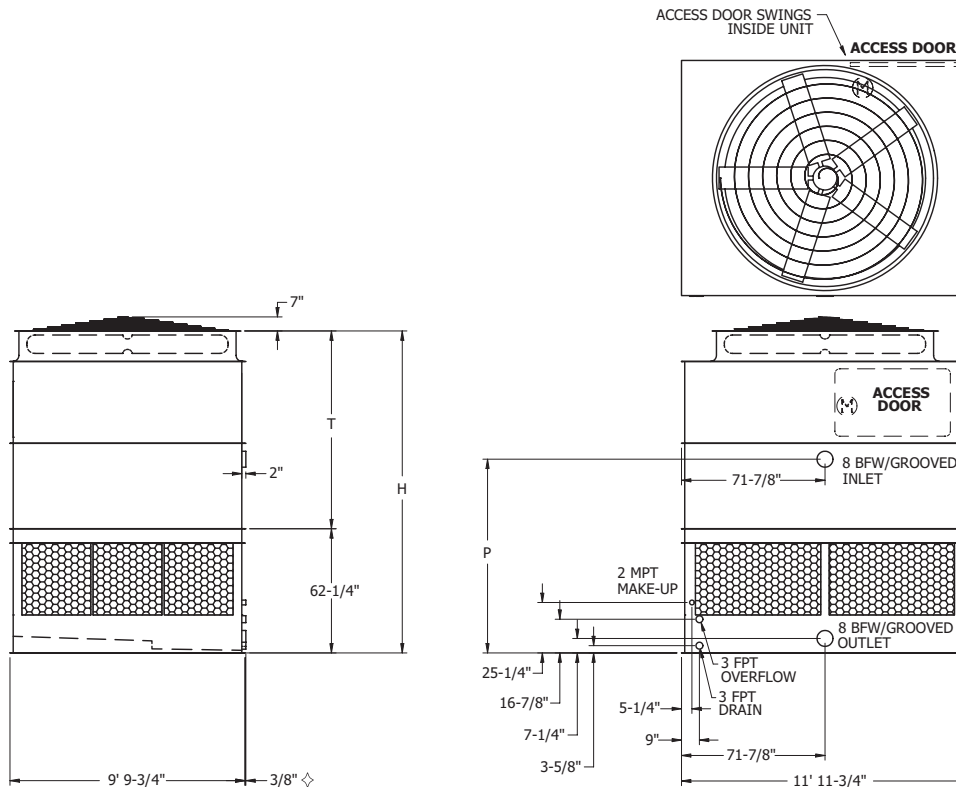

Model No.	Nominal Tonnage	WEIGHTS (LBS)			Fan Motor (HP)	Air Flow (CFM)	DIMENSIONS		
		Shipping	Operating	Heaviest Section†			H†	T†	P
AT 110-2I12	227	6,620	11,580	4,200	10	64,700	13' 5-1/4"	8' 3"	8' 1"
AT 110-2J12	276	6,690	11,650	4,270	15	73,500	13' 5-1/4"	8' 3"	8' 1"
AT 110-2K12	305	6,740	11,700	4,320	20	80,600	13' 5-1/4"	8' 3"	8' 1"
AT 110-2L12	326	6,790	11,750	4,370	25	86,500	13' 5-1/4"	8' 3"	8' 1"
AT 110-2M12	342	6,890	11,850	4,470	30	91,700	13' 5-1/4"	8' 3"	8' 1"
AT 110-3I12	264	7,100	12,060	4,680	10	63,700	14' 5-1/4"	9' 3"	9' 1"
AT 110-3J12	309	7,170	12,130	4,750	15	72,300	14' 5-1/4"	9' 3"	9' 1"
AT 110-3K12	338	7,220	12,180	4,800	20	79,100	14' 5-1/4"	9' 3"	9' 1"
AT 110-3L12	361	7,270	12,230	4,850	25	84,900	14' 5-1/4"	9' 3"	9' 1"
AT 110-3M12	380	7,370	12,330	4,950	30	89,900	14' 5-1/4"	9' 3"	9' 1"
AT 110-4I12	277	7,520	12,480	5,100	10	62,700	15' 5-1/4"	10' 3"	10' 1"
AT 110-4J12	322	7,590	12,550	5,170	15	71,200	15' 5-1/4"	10' 3"	10' 1"
AT 110-4K12	350	7,640	12,600	5,220	20	77,900	15' 5-1/4"	10' 3"	10' 1"
AT 110-4L12	373	7,690	12,650	5,270	25	83,600	15' 5-1/4"	10' 3"	10' 1"
AT 110-4M12	393	7,790	12,750	5,370	30	88,500	15' 5-1/4"	10' 3"	10' 1"
AT 110-4N12	410	8,040	13,000	5,620	35	92,800	15' 5-1/4"	10' 3"	10' 1"
SLSF Addition		700	700	700			1' 9-1/2"	1' 9-1/2"	

- NOTE: (1) An adequately sized bleed line must be installed in the cooling tower system to prevent build-up of impurities in the recirculated water.
 (2) Do not use catalog drawings for certified prints. Dimensions and weights are subject to change.
 (3) Adequate spacing must be allowed for access to the cooling tower. Refer to EVAPCO's Equipment Layout Manual.
 (4) Nominal Tonnage is based on 3 gpm per ton at 95 degree entering water temperature, 85 degree leaving water temperature, and 78 degree wet-bulb temperature.

◇ Outlet connection extends beyond bottom flange.
 † Height includes fan guard which ships factory mounted.

◆ Heaviest section is upper section.

Models: AT/UT/USS 220-2I12 to 220-4N12

Two-Cell Cooling Towers

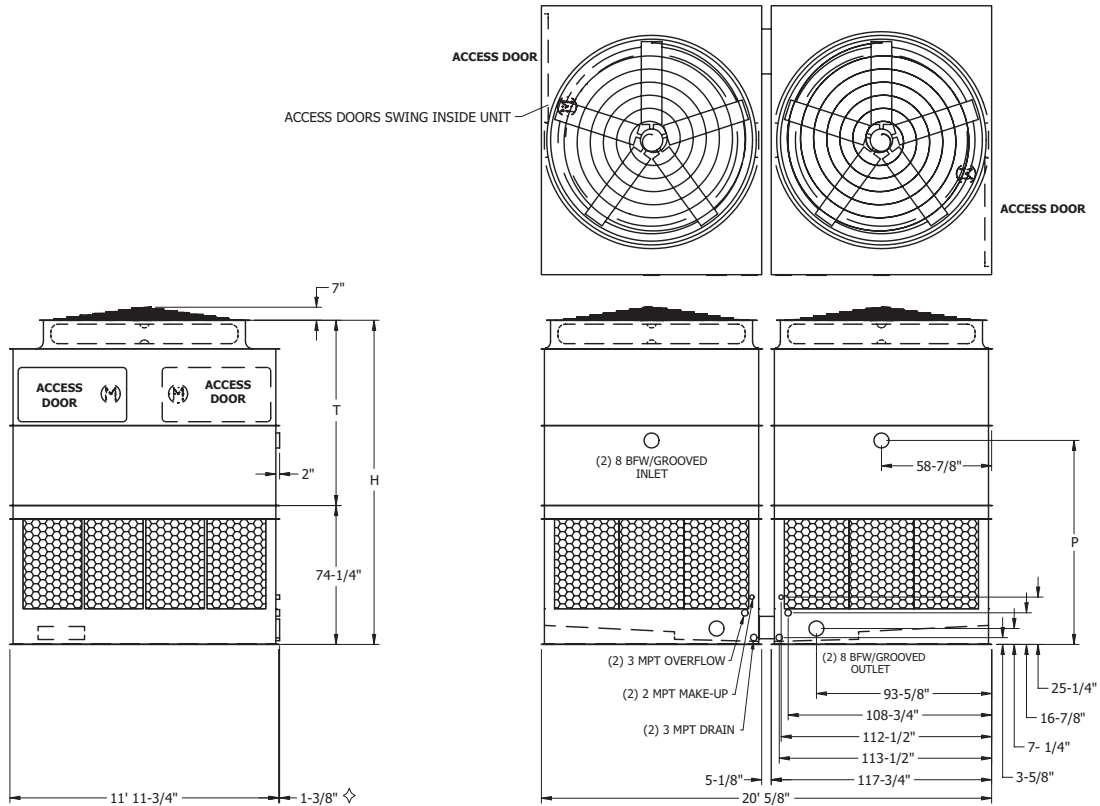

Model No.	Nominal Tonnage	WEIGHTS (LBS)			Fan Motor (HP)	Air Flow (CFM)	DIMENSIONS		
		Shipping	Operating	Heaviest Section†			H†	T†	P
AT 220-2I12	455	13,300	23,220	4,200	(2) 10	128,800	14' 5-1/4"	8' 3"	9' 1"
AT 220-2J12	553	13,440	23,360	4,270	(2) 15	146,300	14' 5-1/4"	8' 3"	9' 1"
AT 220-2K12	611	13,540	23,460	4,320	(2) 20	160,300	14' 5-1/4"	8' 3"	9' 1"
AT 220-2L12	651	13,640	23,560	4,370	(2) 25	172,200	14' 5-1/4"	8' 3"	9' 1"
AT 220-2M12	684	13,840	23,760	4,470	(2) 30	182,500	14' 5-1/4"	8' 3"	9' 1"
AT 220-3I12	529	14,260	24,180	4,680	(2) 10	126,700	15' 5-1/4"	9' 3"	10' 1"
AT 220-3J12	618	14,400	24,320	4,750	(2) 15	143,800	15' 5-1/4"	9' 3"	10' 1"
AT 220-3K12	676	14,500	24,420	4,800	(2) 20	157,400	15' 5-1/4"	9' 3"	10' 1"
AT 220-3L12	722	14,600	24,520	4,850	(2) 25	168,900	15' 5-1/4"	9' 3"	10' 1"
AT 220-3M12	760	14,800	24,720	4,950	(2) 30	179,000	15' 5-1/4"	9' 3"	10' 1"
AT 220-4I12	555	15,100	25,020	5,100	(2) 10	124,700	16' 5-1/4"	10' 3"	11' 1"
AT 220-4J12	644	15,240	25,160	5,170	(2) 15	141,600	16' 5-1/4"	10' 3"	11' 1"
AT 220-4K12	701	15,340	25,260	5,220	(2) 20	155,000	16' 5-1/4"	10' 3"	11' 1"
AT 220-4L12	746	15,440	25,360	5,270	(2) 25	166,300	16' 5-1/4"	10' 3"	11' 1"
AT 220-4M12	785	15,640	25,560	5,370	(2) 30	176,100	16' 5-1/4"	10' 3"	11' 1"
AT 220-4N12	820	16,140	26,060	5,620	(2) 35	184,800	16' 5-1/4"	10' 3"	11' 1"
SLSF Addition		1,400	1,400	700			1' 9-1/2"	1' 9-1/2"	

- NOTE: (1) An adequately sized bleed line must be installed in the cooling tower system to prevent build-up of impurities in the recirculated water.
 (2) Do not use catalog drawings for certified prints. Dimensions and weights are subject to change.
 (3) Adequate spacing must be allowed for access to the cooling tower. Refer to EVAPCO's Equipment Layout Manual.
 (4) Nominal Tonnage is based on 3 gpm per ton at 95 degree entering water temperature, 85 degree leaving water temperature, and 78 degree wet-bulb temperature.

◇ Outlet connection extends beyond bottom flange.
 † Height includes fan guard which ships factory mounted.

◆ Heaviest section is upper section.

Models: AT/UT/USS 210-2124 to 210-4N24

Two-Cell Cooling Towers

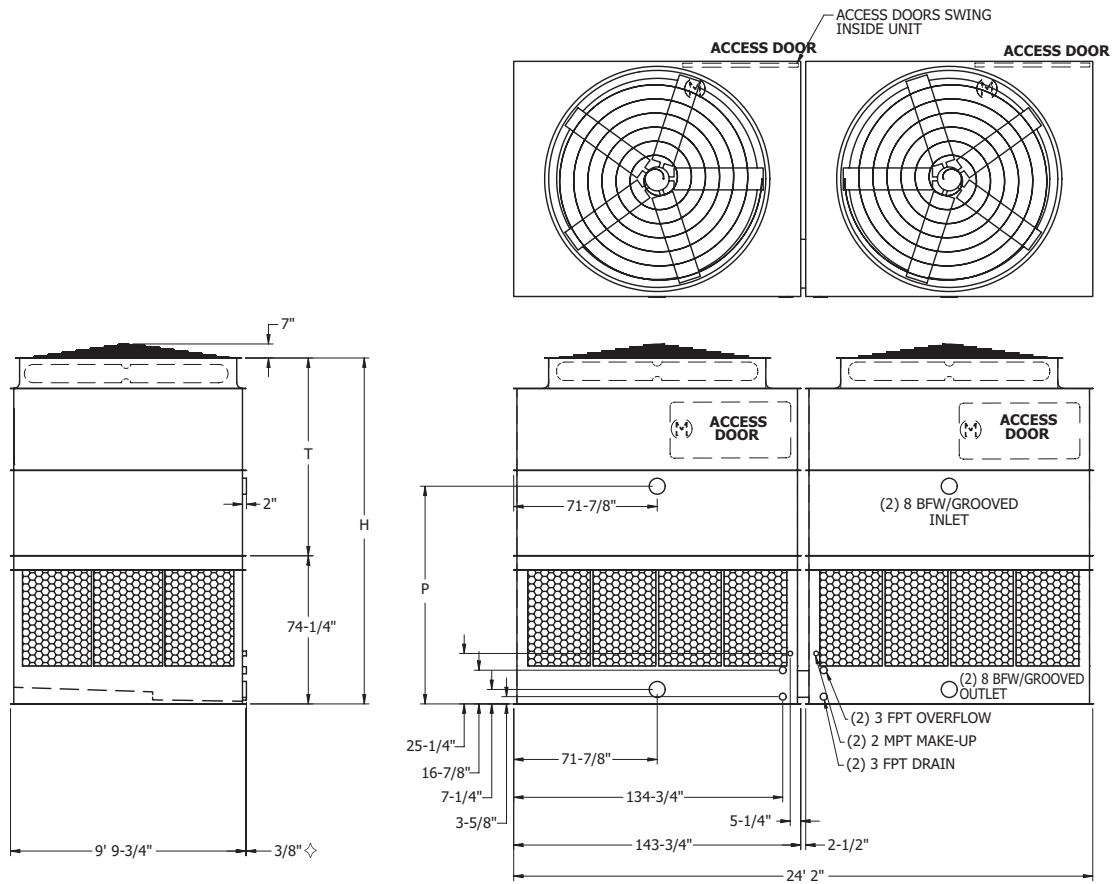

Model No.	Nominal Tonnage	WEIGHTS (LBS)			Fan Motor (HP)	Air Flow (CFM)	DIMENSIONS		
		Shipping	Operating	Heaviest Section†			H†	T†	P
AT 210-2124	455	13,280	23,200	4,200	(2) 10	129,400	14' 5-1/4"	8' 3"	9' 1"
AT 210-2J24	553	13,420	23,340	4,270	(2) 15	147,000	14' 5-1/4"	8' 3"	9' 1"
AT 210-2K24	611	13,520	23,440	4,320	(2) 20	161,100	14' 5-1/4"	8' 3"	9' 1"
AT 210-2L24	651	13,620	23,540	4,370	(2) 25	173,000	14' 5-1/4"	8' 3"	9' 1"
AT 210-2M24	684	13,820	23,740	4,470	(2) 30	183,300	14' 5-1/4"	8' 3"	9' 1"
AT 210-3I24	529	14,240	24,160	4,680	(2) 10	127,300	15' 5-1/4"	9' 3"	10' 1"
AT 210-3J24	618	14,380	24,300	4,750	(2) 15	144,500	15' 5-1/4"	9' 3"	10' 1"
AT 210-3K24	676	14,480	24,400	4,800	(2) 20	158,200	15' 5-1/4"	9' 3"	10' 1"
AT 210-3L24	722	14,580	24,500	4,850	(2) 25	169,700	15' 5-1/4"	9' 3"	10' 1"
AT 210-3M24	760	14,780	24,700	4,950	(2) 30	179,800	15' 5-1/4"	9' 3"	10' 1"
AT 210-4I24	555	15,080	25,000	5,100	(2) 10	125,300	16' 5-1/4"	10' 3"	11' 1"
AT 210-4J24	644	15,220	25,140	5,170	(2) 15	142,300	16' 5-1/4"	10' 3"	11' 1"
AT 210-4K24	701	15,320	25,240	5,220	(2) 20	155,800	16' 5-1/4"	10' 3"	11' 1"
AT 210-4L24	746	15,420	25,340	5,270	(2) 25	167,100	16' 5-1/4"	10' 3"	11' 1"
AT 210-4M24	785	15,620	25,540	5,370	(2) 30	176,900	16' 5-1/4"	10' 3"	11' 1"
AT 210-4N24	820	16,120	26,040	5,620	(2) 40	185,600	16' 5-1/4"	10' 3"	11' 1"
SLSF Addition		1,400	1,400	700			1' 9-1/2"	1' 9-1/2"	

- NOTE: (1) An adequately sized bleed line must be installed in the cooling tower system to prevent build-up of impurities in the recirculated water.
 (2) Do not use catalog drawings for certified prints. Dimensions and weights are subject to change.
 (3) Adequate spacing must be allowed for access to the cooling tower. Refer to EVAPCO's Equipment Layout Manual.
 (4) Nominal Tonnage is based on 3 gpm per ton at 95 degree entering water temperature, 85 degree leaving water temperature, and 78 degree wet-bulb temperature.

◇ Outlet connection extends beyond bottom flange.
 † Height includes fan guard which ships factory mounted.

◆ Heaviest section is upper section.

Models: AT/UT/USS 310-2I36 to 310-4N36

Three-Cell Cooling Towers

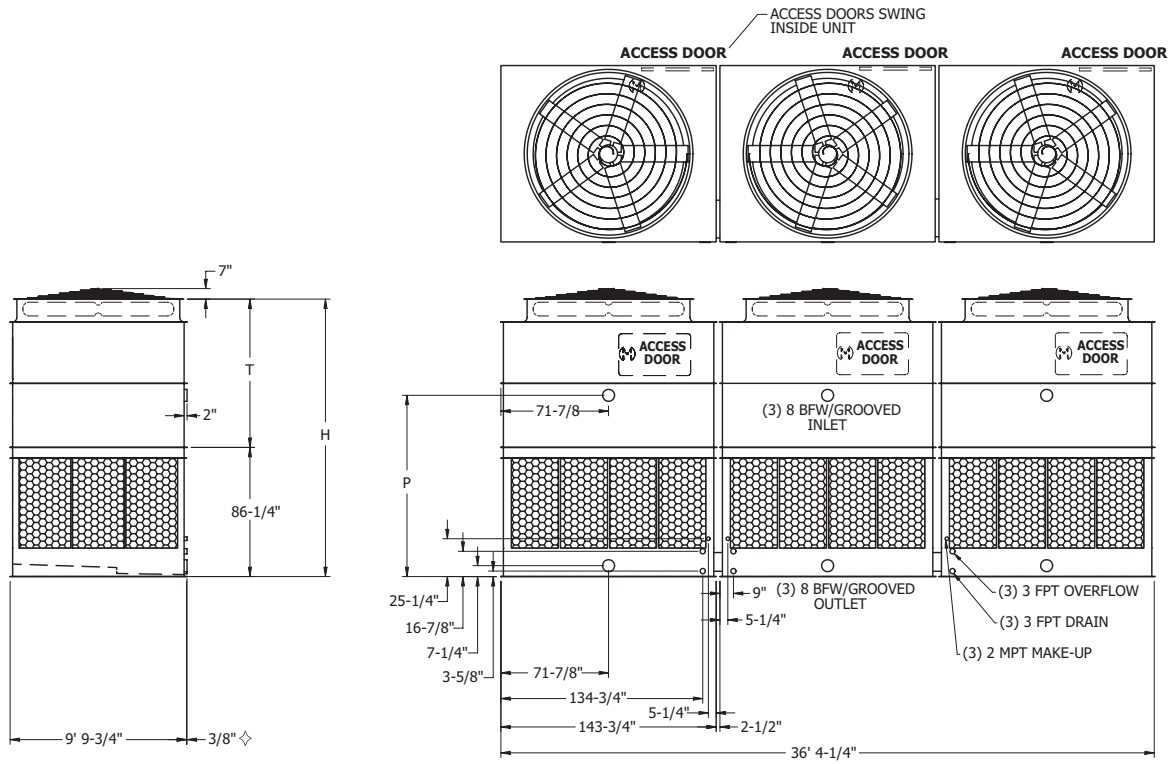

Model No.	Nominal Tonnage	WEIGHTS (LBS)			Fan Motor (HP)	Air Flow (CFM)	DIMENSIONS		
		Shipping	Operating	Heaviest Section†			H†	T†	P
AT 310-2I36	672	20,730	35,780	4,200	(3) 10	194,400	15' 5-1/4"	8' 3"	10' 1"
AT 310-2J36	817	20,940	35,990	4,270	(3) 15	220,800	15' 5-1/4"	8' 3"	10' 1"
AT 310-2K36	903	21,090	36,140	4,320	(3) 20	242,000	15' 5-1/4"	8' 3"	10' 1"
AT 310-2L36	963	21,240	36,290	4,370	(3) 25	259,900	15' 5-1/4"	8' 3"	10' 1"
AT 310-2M36	1,012	21,540	36,590	4,470	(3) 30	275,400	15' 5-1/4"	8' 3"	10' 1"
AT 310-3I36	782	22,170	37,220	4,680	(3) 10	191,200	16' 5-1/4"	9' 3"	11' 1"
AT 310-3J36	914	22,380	37,430	4,750	(3) 15	217,100	16' 5-1/4"	9' 3"	11' 1"
AT 310-3K36	1,000	22,530	37,580	4,800	(3) 20	237,600	16' 5-1/4"	9' 3"	11' 1"
AT 310-3L36	1,068	22,680	37,730	4,850	(3) 25	255,000	16' 5-1/4"	9' 3"	11' 1"
AT 310-3M36	1,126	22,980	38,030	4,950	(3) 30	270,100	16' 5-1/4"	9' 3"	11' 1"
AT 310-4I36	821	23,430	38,480	5,100	(3) 10	188,100	17' 5-1/4"	10' 3"	12' 1"
AT 310-4J36	953	23,640	38,690	5,170	(3) 15	213,700	17' 5-1/4"	10' 3"	12' 1"
AT 310-4K36	1,038	23,790	38,840	5,220	(3) 20	234,000	17' 5-1/4"	10' 3"	12' 1"
AT 310-4L36	1,106	23,940	38,990	5,270	(3) 25	251,000	17' 5-1/4"	10' 3"	12' 1"
AT 310-4M36	1,164	24,240	39,290	5,370	(3) 30	265,800	17' 5-1/4"	10' 3"	12' 1"
AT 310-4N36	1,216	24,990	40,040	5,620	(3) 35	278,900	17' 5-1/4"	10' 3"	12' 1"
SLSF Addition		2,100	2,100	700			1' 9-1/2"	1' 9-1/2"	

- NOTE: (1) An adequately sized bleed line must be installed in the cooling tower system to prevent build-up of impurities in the recirculated water.
 (2) Do not use catalog drawings for certified prints. Dimensions and weights are subject to change.
 (3) Adequate spacing must be allowed for access to the cooling tower. Refer to EVAPCO's Equipment Layout Manual.
 (4) Nominal Tonnage is based on 3 gpm per ton at 95 degree entering water temperature, 85 degree leaving water temperature, and 78 degree wet-bulb temperature.

◇ Outlet connection extends beyond bottom flange.
 † Height includes fan guard which ships factory mounted.

◆ Heaviest section is upper section.

Models: AT/UT/USS 110-2118 to 110-4N18

One-Cell Cooling Towers

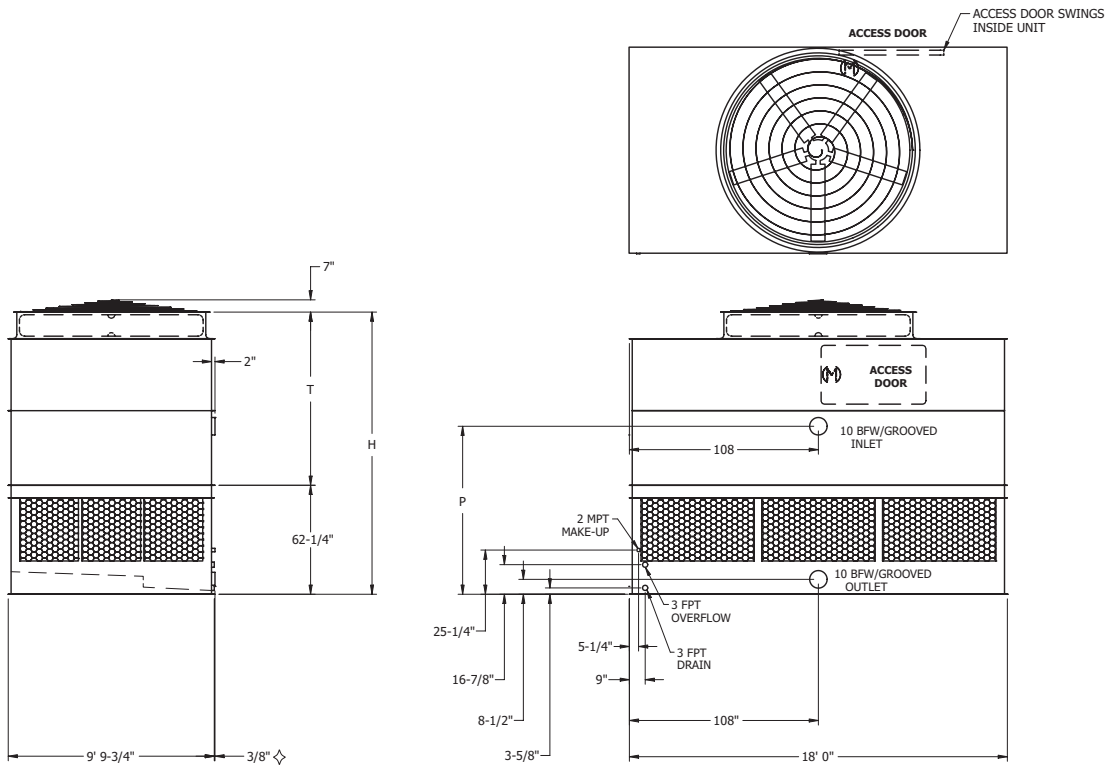

Model No.	Nominal Tonnage	WEIGHTS (LBS)			Fan Motor (HP)	Air Flow (CFM)	DIMENSIONS		
		Shipping	Operating	Heaviest Section†			H†	T†	P
AT 110-2118	290	9,190	16,790	5,640	10	86,000	13' 5-1/4"	8' 3"	8' 0"
AT 110-2118	351	9,260	16,860	5,710	15	97,800	13' 5-1/4"	8' 3"	8' 0"
AT 110-2K18	389	9,310	16,910	5,760	20	107,200	13' 5-1/4"	8' 3"	8' 0"
AT 110-2L18	420	9,360	16,960	5,810	25	115,100	13' 5-1/4"	8' 3"	8' 0"
AT 110-2M18	445	9,460	17,060	5,910	30	122,000	13' 5-1/4"	8' 3"	8' 0"
AT 110-3118	333	9,880	17,480	6,330	10	84,700	14' 5-1/4"	9' 3"	9' 0"
AT 110-3118	395	9,950	17,550	6,400	15	96,300	14' 5-1/4"	9' 3"	9' 0"
AT 110-3K18	437	10,000	17,600	6,450	20	105,500	14' 5-1/4"	9' 3"	9' 0"
AT 110-3L18	471	10,050	17,650	6,500	25	113,100	14' 5-1/4"	9' 3"	9' 0"
AT 110-3M18	499	10,150	17,750	6,600	30	119,800	14' 5-1/4"	9' 3"	9' 0"
AT 110-3N18	547	10,400	18,000	6,850	40	131,100	14' 5-1/4"	9' 3"	9' 0"
AT 110-4118	364	10,510	18,110	6,960	10	83,300	15' 5-1/4"	10' 3"	10' 0"
AT 110-4118	420	10,580	18,180	7,030	15	94,700	15' 5-1/4"	10' 3"	10' 0"
AT 110-4K18	460	10,630	18,230	7,080	20	103,800	15' 5-1/4"	10' 3"	10' 0"
AT 110-4L18	493	10,680	18,280	7,130	25	111,300	15' 5-1/4"	10' 3"	10' 0"
AT 110-4M18	522	10,780	18,380	7,230	30	117,900	15' 5-1/4"	10' 3"	10' 0"
AT 110-4N18	570	11,030	18,630	7,480	40	129,000	15' 5-1/4"	10' 3"	10' 0"
SLSF Addition		700	700	700			1' 9-1/2"	1' 9-1/2"	

- NOTE: (1) An adequately sized bleed line must be installed in the cooling tower system to prevent build-up of impurities in the recirculated water.
 (2) Do not use catalog drawings for certified prints. Dimensions and weights are subject to change.
 (3) Adequate spacing must be allowed for access to the cooling tower. Refer to EVAPCO's Equipment Layout Manual.
 (4) Nominal Tonnage is based on 3 gpm per ton at 95 degree entering water temperature, 85 degree leaving water temperature, and 78 degree wet-bulb temperature.
 (5) This box size is available in a dual fan/cell configuration.

◇ Outlet connection extends beyond bottom flange.
 † Height includes fan guard which ships factory mounted.

◆ Heaviest section is upper section.

Models: AT/UT/USS 220-2I18 to 220-4N18

Two-Cell Cooling Towers

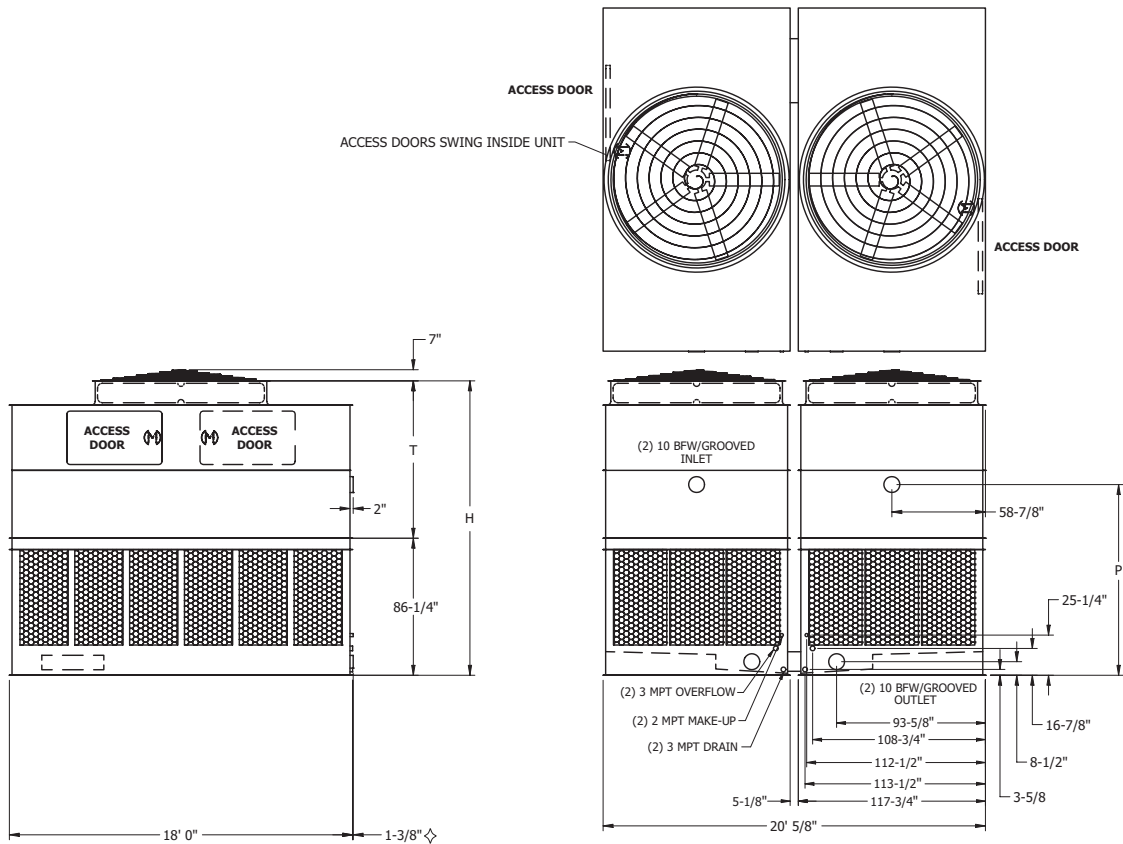

Model No.	Nominal Tonnage	WEIGHTS (LBS)			Fan Motor (HP)	Air Flow (CFM)	DIMENSIONS		
		Shipping	Operating	Heaviest Section [‡]			H [†]	T [†]	P
AT 220-2I18	580	19,100	34,300	5,640	(2) 10	171,200	15' 5-1/4"	8' 3"	10' 0"
AT 220-2J18	701	19,240	34,440	5,710	(2) 15	194,700	15' 5-1/4"	8' 3"	10' 0"
AT 220-2K18	779	19,340	34,540	5,760	(2) 20	213,400	15' 5-1/4"	8' 3"	10' 0"
AT 220-2L18	840	19,440	34,640	5,810	(2) 25	229,100	15' 5-1/4"	8' 3"	10' 0"
AT 220-2M18	890	19,640	34,840	5,910	(2) 30	242,900	15' 5-1/4"	8' 3"	10' 0"
AT 220-3I18	667	20,480	35,680	6,330	(2) 10	168,600	16' 5-1/4"	9' 3"	11' 0"
AT 220-3J18	790	20,620	35,820	6,400	(2) 15	191,700	16' 5-1/4"	9' 3"	11' 0"
AT 220-3K18	873	20,720	35,920	6,450	(2) 20	209,900	16' 5-1/4"	9' 3"	11' 0"
AT 220-3L18	941	20,820	36,020	6,500	(2) 25	225,100	16' 5-1/4"	9' 3"	11' 0"
AT 220-3M18	997	21,020	36,220	6,600	(2) 30	238,400	16' 5-1/4"	9' 3"	11' 0"
AT 220-3N18	1,093	21,520	36,720	6,850	(2) 40	260,900	16' 5-1/4"	9' 3"	11' 0"
AT 220-4I18	727	21,740	36,940	6,960	(2) 10	165,700	17' 5-1/4"	10' 3"	12' 0"
AT 220-4J18	839	21,880	37,080	7,030	(2) 15	188,500	17' 5-1/4"	10' 3"	12' 0"
AT 220-4K18	921	21,980	37,180	7,080	(2) 20	206,500	17' 5-1/4"	10' 3"	12' 0"
AT 220-4L18	987	22,080	37,280	7,130	(2) 25	221,600	17' 5-1/4"	10' 3"	12' 0"
AT 220-4M18	1,044	22,280	37,480	7,230	(2) 30	234,700	17' 5-1/4"	10' 3"	12' 0"
AT 220-4N18	1,140	22,780	37,980	7,480	(2) 40	256,800	17' 5-1/4"	10' 3"	12' 0"
SLSF Addition		1,400	1,400	700			1' 9-1/2"	1' 9-1/2"	

- NOTE: (1) An adequately sized bleed line must be installed in the cooling tower system to prevent build-up of impurities in the recirculated water.
 (2) Do not use catalog drawings for certified prints. Dimensions and weights are subject to change.
 (3) Adequate spacing must be allowed for access to the cooling tower. Refer to EVAPCO's Equipment Layout Manual.
 (4) Nominal Tonnage is based on 3 gpm per ton at 95 degree entering water temperature, 85 degree leaving water temperature, and 78 degree wet-bulb temperature.
 (5) This box size is available in a dual fan/cell configuration.

◇ Outlet connection extends beyond bottom flange.

◆ Heaviest section is upper section.

† Height includes fan guard which ships factory mounted.

Models: AT/UT/USS 210-2136 to 210-4N36

Two-Cell Cooling Towers

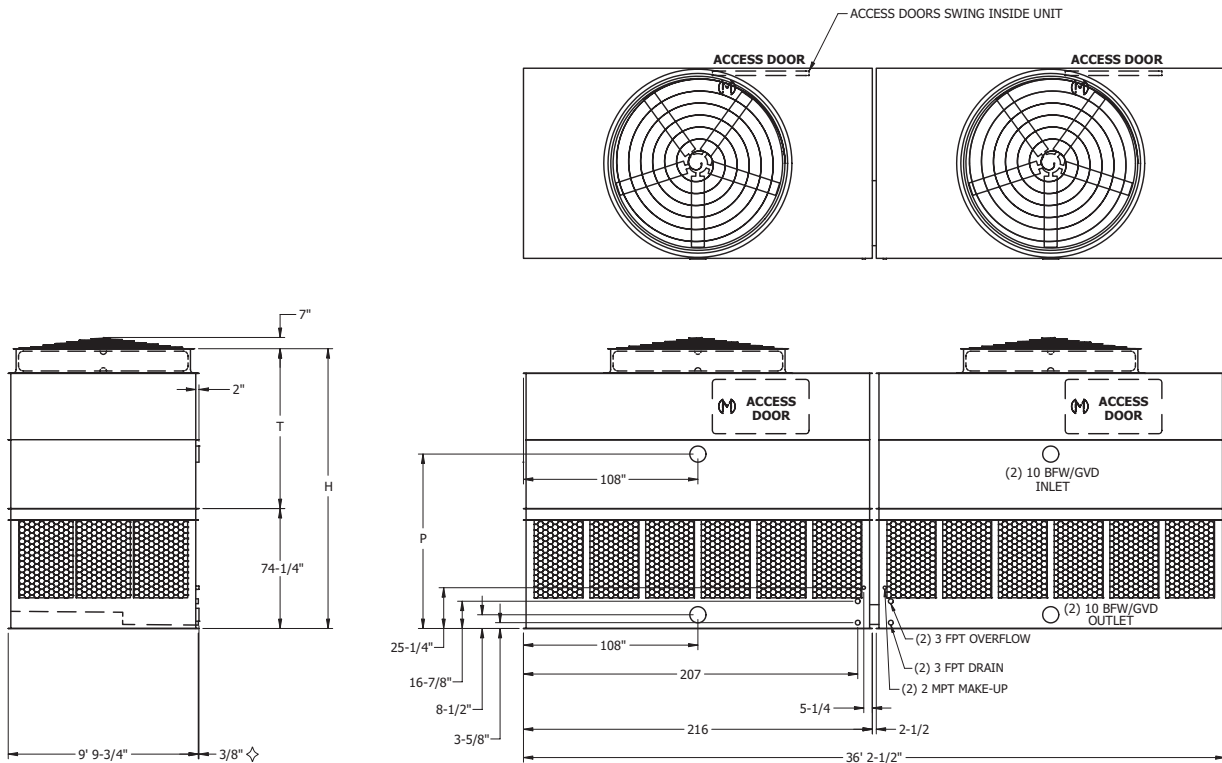

Model No.	Nominal Tonnage	WEIGHTS (LBS)			Fan Motor (HP)	Air Flow (CFM)	DIMENSIONS		
		Shipping	Operating	Heaviest Section†			H†	T†	P
AT 210-2136	580	18,440	33,640	5,640	(2) 10	172,000	14' 5-1/4"	8' 3"	9' 0"
AT 210-2J36	701	18,580	33,780	5,710	(2) 15	195,600	14' 5-1/4"	8' 3"	9' 0"
AT 210-2K36	779	18,680	33,880	5,760	(2) 20	214,400	14' 5-1/4"	8' 3"	9' 0"
AT 210-2L36	840	18,780	33,980	5,810	(2) 25	230,200	14' 5-1/4"	8' 3"	9' 0"
AT 210-2M36	890	18,980	34,180	5,910	(2) 30	244,000	14' 5-1/4"	8' 3"	9' 0"
AT 210-3I36	667	19,820	35,020	6,330	(2) 10	169,400	15' 5-1/4"	9' 3"	10' 0"
AT 210-3J36	790	19,960	35,160	6,400	(2) 15	192,600	15' 5-1/4"	9' 3"	10' 0"
AT 210-3K36	873	20,060	35,260	6,450	(2) 20	210,900	15' 5-1/4"	9' 3"	10' 0"
AT 210-3L36	941	20,160	35,360	6,500	(2) 25	226,200	15' 5-1/4"	9' 3"	10' 0"
AT 210-3M36	997	20,360	35,560	6,600	(2) 30	239,500	15' 5-1/4"	9' 3"	10' 0"
AT 210-3N36	1,093	20,860	36,060	6,850	(2) 40	262,100	15' 5-1/4"	9' 3"	10' 0"
AT 210-4I36	727	21,080	36,280	6,960	(2) 10	166,500	16' 5-1/4"	10' 3"	11' 0"
AT 210-4J36	839	21,220	36,420	7,030	(2) 15	189,400	16' 5-1/4"	10' 3"	11' 0"
AT 210-4K36	921	21,320	36,520	7,080	(2) 20	207,500	16' 5-1/4"	10' 3"	11' 0"
AT 210-4L36	987	21,420	36,620	7,130	(2) 25	222,600	16' 5-1/4"	10' 3"	11' 0"
AT 210-4M36	1,044	21,620	36,820	7,230	(2) 30	235,700	16' 5-1/4"	10' 3"	11' 0"
AT 210-4N36	1,140	22,120	37,320	7,480	(2) 40	257,900	16' 5-1/4"	10' 3"	11' 0"
SLSF Addition		1,400	1,400	700			1' 9-1/2"	1' 9-1/2"	

- NOTE: (1) An adequately sized bleed line must be installed in the cooling tower system to prevent build-up of impurities in the recirculated water.
 (2) Do not use catalog drawings for certified prints. Dimensions and weights are subject to change.
 (3) Adequate spacing must be allowed for access to the cooling tower. Refer to EVAPCO's Equipment Layout Manual.
 (4) Nominal Tonnage is based on 3 gpm per ton at 95 degree entering water temperature, 85 degree leaving water temperature, and 78 degree wet-bulb temperature.
 (5) This box size is available in a dual fan/cell configuration.

◇ Outlet connection extends beyond bottom flange.
 † Height includes fan guard which ships factory mounted.

◆ Heaviest section is upper section.

Models: AT/UT/USS 112-2I12 to 112-4N12

One-Cell Cooling Towers

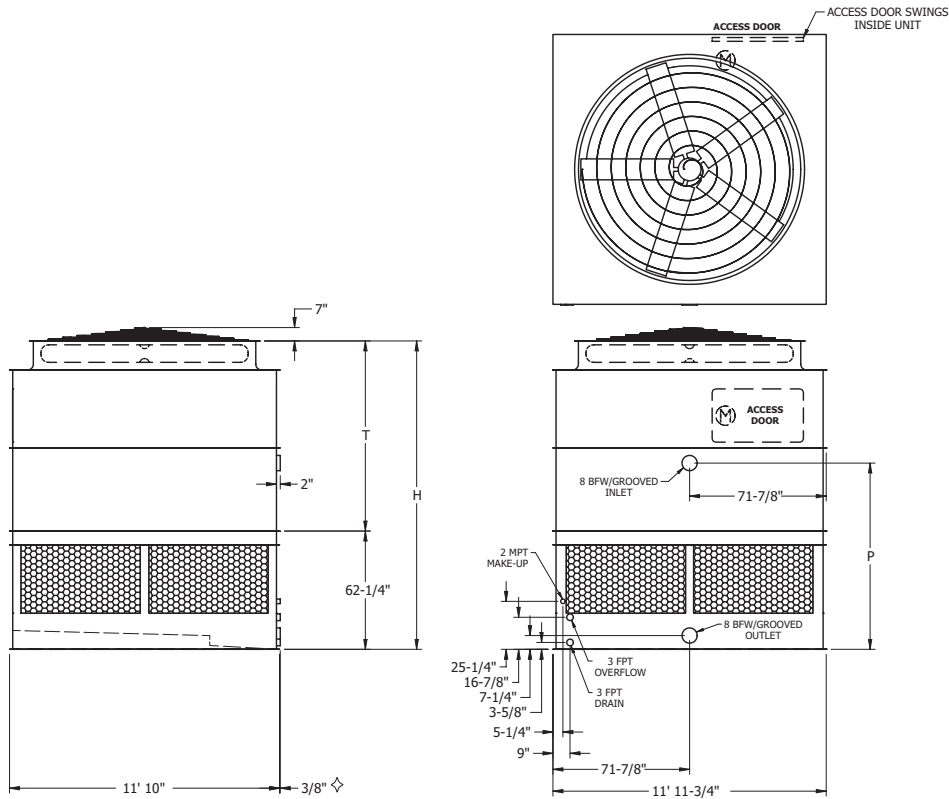

Model No.	Nominal Tonnage	WEIGHTS (LBS)			Fan Motor (HP)	Air Flow (CFM)	DIMENSIONS		
		Shipping	Operating	Heaviest Section†			H†	T†	P
AT 112-2I12	280	7,330	13,540	4,930	10	71,600	13' 6-1/4"	8' 4"	8' 2"
AT 112-2J12	334	7,400	13,610	5,000	15	81,400	13' 6-1/4"	8' 4"	8' 2"
AT 112-2K12	364	7,450	13,660	5,050	20	89,200	13' 6-1/4"	8' 4"	8' 2"
AT 112-2L12	391	7,500	13,710	5,100	25	95,800	13' 6-1/4"	8' 4"	8' 2"
AT 112-2M12	414	7,600	13,810	5,200	30	101,500	13' 6-1/4"	8' 4"	8' 2"
AT 112-3I12	316	7,870	14,080	5,470	10	70,500	14' 6-1/4"	9' 4"	9' 2"
AT 112-3J12	370	7,940	14,150	5,540	15	80,000	14' 6-1/4"	9' 4"	9' 2"
AT 112-3K12	404	7,990	14,200	5,590	20	87,600	14' 6-1/4"	9' 4"	9' 2"
AT 112-3L12	434	8,040	14,250	5,640	25	93,900	14' 6-1/4"	9' 4"	9' 2"
AT 112-3M12	461	8,140	14,350	5,740	30	99,500	14' 6-1/4"	9' 4"	9' 2"
AT 112-4I12	337	8,360	14,570	5,960	10	69,300	15' 6-1/4"	10' 4"	10' 2"
AT 112-4J12	387	8,430	14,640	6,030	15	78,800	15' 6-1/4"	10' 4"	10' 2"
AT 112-4K12	422	8,480	14,690	6,080	20	86,200	15' 6-1/4"	10' 4"	10' 2"
AT 112-4L12	454	8,530	14,740	6,130	25	92,400	15' 6-1/4"	10' 4"	10' 2"
AT 112-4M12	481	8,630	14,840	6,230	30	97,800	15' 6-1/4"	10' 4"	10' 2"
AT 112-4N12	515	8,880	15,090	6,480	40	107,100	15' 6-1/4"	10' 4"	10' 2"
SLSF Addition		700	700	700			1' 9-1/2"	1' 9-1/2"	

- NOTE: (1) An adequately sized bleed line must be installed in the cooling tower system to prevent build-up of impurities in the recirculated water.
 (2) Do not use catalog drawings for certified prints. Dimensions and weights are subject to change.
 (3) Adequate spacing must be allowed for access to the cooling tower. Refer to EVAPCO's Equipment Layout Manual.
 (4) Nominal Tonnage is based on 3 gpm per ton at 95 degree entering water temperature, 85 degree leaving water temperature, and 78 degree wet-bulb temperature.

◇ Outlet connection extends beyond bottom flange.
 † Height includes fan guard which ships factory mounted.

◆ Heaviest section is upper section.

Models: AT/UT/USS 212-2124 to 212-4N24

Two-Cell Cooling Towers

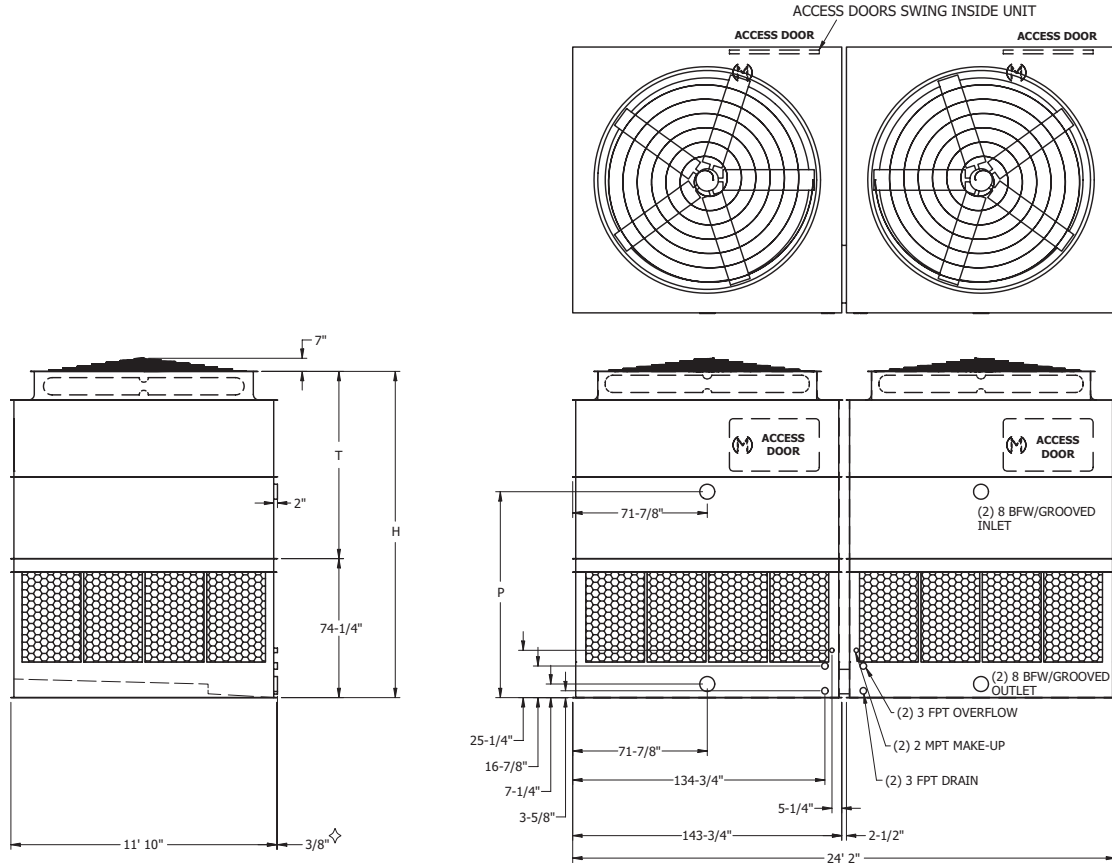

Model No.	Nominal Tonnage	WEIGHTS (LBS)			Fan Motor (HP)	Air Flow (CFM)	DIMENSIONS		
		Shipping	Operating	Heaviest Section†			H†	T†	P
AT 212-2124	560	14,800	27,220	4,860	(2) 10	143,100	14' 6-1/4"	8' 4"	9' 2"
AT 212-2J24	667	15,080	27,500	5,000	(2) 15	162,700	14' 6-1/4"	8' 4"	9' 2"
AT 212-2K24	729	15,180	27,600	5,050	(2) 20	178,300	14' 6-1/4"	8' 4"	9' 2"
AT 212-2L24	782	15,280	27,700	5,100	(2) 25	191,500	14' 6-1/4"	8' 4"	9' 2"
AT 212-2M24	828	15,480	27,900	5,200	(2) 30	202,900	14' 6-1/4"	8' 4"	9' 2"
AT 212-3124	633	15,880	28,300	5,400	(2) 10	140,900	15' 6-1/4"	9' 4"	10' 2"
AT 212-3J24	740	16,160	28,580	5,540	(2) 15	160,000	15' 6-1/4"	9' 4"	10' 2"
AT 212-3K24	807	16,260	28,680	5,590	(2) 20	175,100	15' 6-1/4"	9' 4"	10' 2"
AT 212-3L24	868	16,360	28,780	5,640	(2) 25	187,800	15' 6-1/4"	9' 4"	10' 2"
AT 212-3M24	922	16,560	28,980	5,740	(2) 30	198,900	15' 6-1/4"	9' 4"	10' 2"
AT 212-4124	674	16,860	29,280	5,890	(2) 10	138,600	16' 6-1/4"	10' 4"	11' 2"
AT 212-4J24	775	17,140	29,560	6,030	(2) 15	157,500	16' 6-1/4"	10' 4"	11' 2"
AT 212-4K24	843	17,240	29,660	6,080	(2) 20	172,400	16' 6-1/4"	10' 4"	11' 2"
AT 212-4L24	908	17,340	29,760	6,130	(2) 25	184,800	16' 6-1/4"	10' 4"	11' 2"
AT 212-4M24	963	17,540	29,960	6,230	(2) 30	195,600	16' 6-1/4"	10' 4"	11' 2"
AT 212-4N24	1,030	18,040	30,460	6,480	(2) 40	214,100	16' 6-1/4"	10' 4"	11' 2"
SLSF Addition		1,400	1,400	700			1' 9-1/2"	1' 9-1/2"	

- NOTE: (1) An adequately sized bleed line must be installed in the cooling tower system to prevent build-up of impurities in the recirculated water.
 (2) Do not use catalog drawings for certified prints. Dimensions and weights are subject to change.
 (3) Adequate spacing must be allowed for access to the cooling tower. Refer to EVAPCO's Equipment Layout Manual.
 (4) Nominal Tonnage is based on 3 gpm per ton at 95 degree entering water temperature, 85 degree leaving water temperature, and 78 degree wet-bulb temperature.

◇ Outlet connection extends beyond bottom flange.

◆ Heaviest section is upper section.

† Height includes fan guard which ships factory mounted.

Models: AT/UT/USS 312-2136 to 312-4N36

Three-Cell Cooling Towers

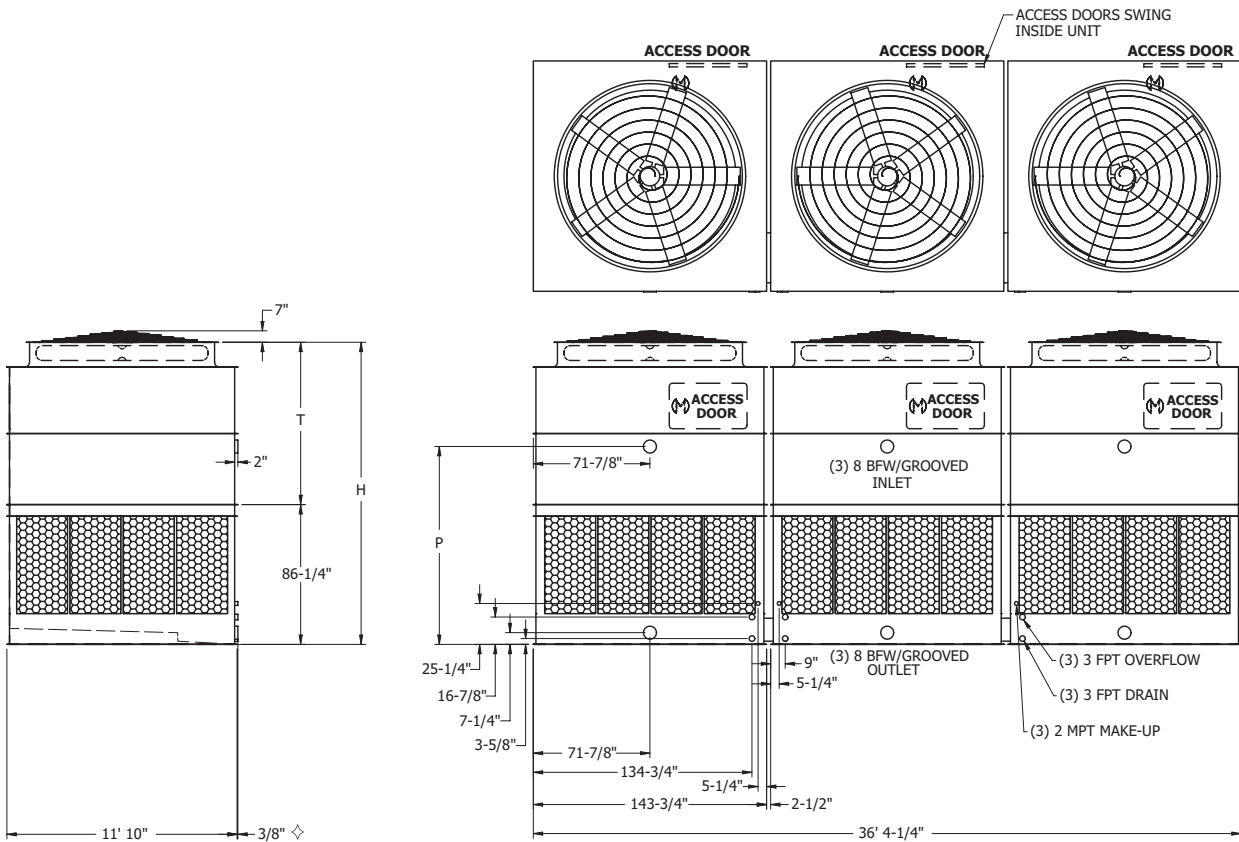

Model No.	Nominal Tonnage	WEIGHTS (LBS)			Fan Motor (HP)	Air Flow (CFM)	DIMENSIONS		
		Shipping	Operating	Heaviest Section†			H†	T†	P
AT 312-2136	851	22,830	41,460	4,930	(3) 10	216,800	15' 6-1/4"	8' 4"	10' 2"
AT 312-2J36	1,014	23,040	41,670	5,000	(3) 15	246,400	15' 6-1/4"	8' 4"	10' 2"
AT 312-2K36	1,106	23,190	41,820	5,050	(3) 20	270,100	15' 6-1/4"	8' 4"	10' 2"
AT 312-2L36	1,187	23,340	41,970	5,100	(3) 25	290,000	15' 6-1/4"	8' 4"	10' 2"
AT 312-2M36	1,257	23,640	42,270	5,200	(3) 30	307,200	15' 6-1/4"	8' 4"	10' 2"
AT 312-3I36	960	24,450	43,080	5,470	(3) 10	213,500	16' 6-1/4"	9' 4"	11' 2"
AT 312-3J36	1,122	24,660	43,290	5,540	(3) 15	242,300	16' 6-1/4"	9' 4"	11' 2"
AT 312-3K36	1,224	24,810	43,440	5,590	(3) 20	265,300	16' 6-1/4"	9' 4"	11' 2"
AT 312-3L36	1,316	24,960	43,590	5,640	(3) 25	284,500	16' 6-1/4"	9' 4"	11' 2"
AT 312-3M36	1,398	25,260	43,890	5,740	(3) 30	301,300	16' 6-1/4"	9' 4"	11' 2"
AT 312-4I36	1,021	25,920	44,550	5,960	(3) 10	209,900	17' 6-1/4"	10' 4"	12' 2"
AT 312-4J36	1,174	26,130	44,760	6,030	(3) 15	238,500	17' 6-1/4"	10' 4"	12' 2"
AT 312-4K36	1,277	26,280	44,910	6,080	(3) 20	261,100	17' 6-1/4"	10' 4"	12' 2"
AT 312-4L36	1,375	26,430	45,060	6,130	(3) 25	279,900	17' 6-1/4"	10' 4"	12' 2"
AT 312-4M36	1,458	26,730	45,360	6,230	(3) 30	296,200	17' 6-1/4"	10' 4"	12' 2"
AT 312-4N36	1,560	27,480	46,110	6,480	(3) 40	324,200	17' 6-1/4"	10' 4"	12' 2"
SLSF Addition		2,100	2,100	700			1' 9-1/2"	1' 9-1/2"	

- NOTE: (1) An adequately sized bleed line must be installed in the cooling tower system to prevent build-up of impurities in the recirculated water.
(2) Do not use catalog drawings for certified prints. Dimensions and weights are subject to change.
(3) Adequate spacing must be allowed for access to the cooling tower. Refer to EVAPCO's Equipment Layout Manual.
(4) Nominal Tonnage is based on 3 gpm per ton at 95 degree entering water temperature, 85 degree leaving water temperature, and 78 degree wet-bulb temperature.

◇ Outlet connection extends beyond bottom flange.
† Height includes fan guard which ships factory mounted.

◆ Heaviest section is upper section.

Models: AT/UT/USS 424-2I24 to 424-4N24

Four-Cell Cooling Towers

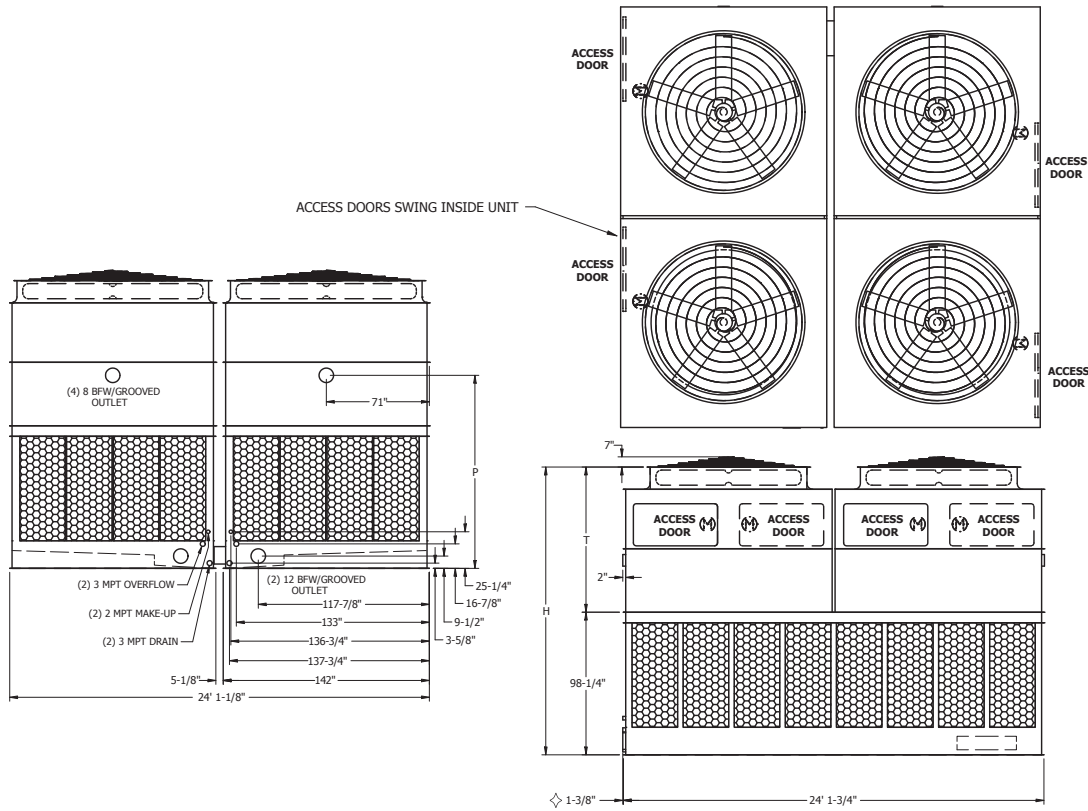

Model No.	Nominal Tonnage	WEIGHTS (LBS)			Fan Motor (HP)	Air Flow (CFM)	DIMENSIONS		
		Shipping	Operating	Heaviest Section†			H†	T†	P
AT 424-2I24	1,114	31,020	55,340	5,790	(4) 10	283,500	16' 6-1/4"	8' 4"	11' 2"
AT 424-2J24	1,327	31,580	55,900	5,790	(4) 15	322,300	16' 6-1/4"	8' 4"	11' 2"
AT 424-2K24	1,449	31,780	56,100	5,790	(4) 20	353,400	16' 6-1/4"	8' 4"	11' 2"
AT 424-2L24	1,555	31,980	56,300	5,790	(4) 25	379,400	16' 6-1/4"	8' 4"	11' 2"
AT 424-2M24	1,647	32,380	56,700	5,790	(4) 30	401,900	16' 6-1/4"	8' 4"	11' 2"
AT 424-3I24	1,257	33,180	57,500	5,790	(4) 10	279,200	17' 6-1/4"	9' 4"	12' 2"
AT 424-3J24	1,471	33,740	58,060	5,790	(4) 15	317,000	17' 6-1/4"	9' 4"	12' 2"
AT 424-3K24	1,605	33,940	58,260	5,790	(4) 20	347,000	17' 6-1/4"	9' 4"	12' 2"
AT 424-3L24	1,727	34,140	58,460	5,790	(4) 25	372,200	17' 6-1/4"	9' 4"	12' 2"
AT 424-3M24	1,835	34,540	58,860	5,790	(4) 30	394,100	17' 6-1/4"	9' 4"	12' 2"
AT 424-4I24	1,340	35,140	59,460	5,890	(4) 10	274,500	18' 6-1/4"	10' 4"	13' 2"
AT 424-4J24	1,542	35,700	60,020	6,030	(4) 15	312,000	18' 6-1/4"	10' 4"	13' 2"
AT 424-4K24	1,678	35,900	60,220	6,080	(4) 20	341,600	18' 6-1/4"	10' 4"	13' 2"
AT 424-4L24	1,807	36,100	60,420	6,130	(4) 25	366,200	18' 6-1/4"	10' 4"	13' 2"
AT 424-4M24	1,916	36,500	60,820	6,230	(4) 30	387,500	18' 6-1/4"	10' 4"	13' 2"
AT 424-4N24	2,050	37,500	61,820	6,480	(4) 40	424,300	18' 6-1/4"	10' 4"	13' 2"
SLSF Addition		2,800	2,800	700			1' 9-1/2"	1' 9-1/2"	

NOTE: (1) An adequately sized bleed line must be installed in the cooling tower system to prevent build-up of impurities in the recirculated water.
 (2) Do not use catalog drawings for certified prints. Dimensions and weights are subject to change.
 (3) Adequate spacing must be allowed for access to the cooling tower. Refer to EVAPCO's Equipment Layout Manual.
 (4) Nominal Tonnage is based on 3 gpm per ton at 95 degree entering water temperature, 85 degree leaving water temperature, and 78 degree wet-bulb temperature.

◇ Outlet connection extends beyond bottom flange. † Height includes fan guard which ships factory mounted.

◆ L= Lower Section, U= Upper Section

Models: AT/UT/USS 112-2I14 to 112-4N14

One-Cell Cooling Towers

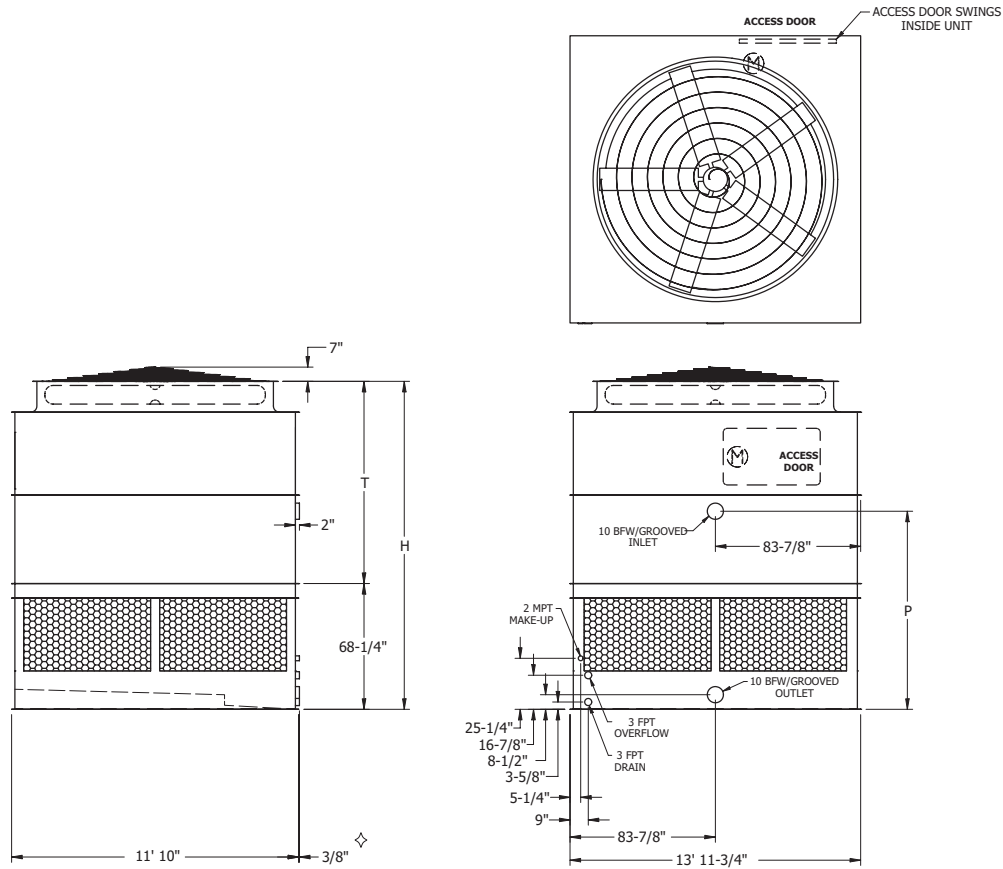

Model No.	Nominal Tonnage	WEIGHTS (LBS)			Fan Motor (HP)	Air Flow (CFM)	DIMENSIONS		
		Shipping	Operating	Heaviest Section†			H†	T†	P
AT 112-2I14	299	8,230	15,560	5,360	10	77,800	14' 1/4"	8' 4"	8' 7"
AT 112-2J14	359	8,300	15,630	5,430	15	88,500	14' 1/4"	8' 4"	8' 7"
AT 112-2K14	394	8,360	15,690	5,490	20	97,000	14' 1/4"	8' 4"	8' 7"
AT 112-2L14	425	8,420	15,750	5,550	25	104,100	14' 1/4"	8' 4"	8' 7"
AT 112-2M14	450	8,490	15,820	5,620	30	110,400	14' 1/4"	8' 4"	8' 7"
AT 112-3I14	344	8,890	16,220	6,020	10	76,600	15' 1/4"	9' 4"	9' 7"
AT 112-3J14	405	8,960	16,290	6,090	15	87,000	15' 1/4"	9' 4"	9' 7"
AT 112-3K14	439	9,020	16,350	6,150	20	95,400	15' 1/4"	9' 4"	9' 7"
AT 112-3L14	471	9,080	16,410	6,210	25	102,300	15' 1/4"	9' 4"	9' 7"
AT 112-3M14	501	9,150	16,480	6,280	30	108,300	15' 1/4"	9' 4"	9' 7"
AT 112-3N14	548	9,410	16,740	6,540	40	118,600	15' 1/4"	9' 4"	9' 7"
AT 112-4I14	370	9,410	16,740	6,540	10	75,300	16' 1/4"	10' 4"	10' 7"
AT 112-4J14	427	9,480	16,810	6,610	15	85,600	16' 1/4"	10' 4"	10' 7"
AT 112-4K14	460	9,540	16,870	6,670	20	93,800	16' 1/4"	10' 4"	10' 7"
AT 112-4L14	494	9,600	16,930	6,730	25	100,600	16' 1/4"	10' 4"	10' 7"
AT 112-4M14	524	9,670	17,000	6,800	30	106,500	16' 1/4"	10' 4"	10' 7"
AT 112-4N14	574	9,930	17,260	7,060	40	116,500	16' 1/4"	10' 4"	10' 7"
SLSF Addition		1,200	1,200	1,200			1' 9-1/2"	1' 9-1/2"	

- NOTE: (1) An adequately sized bleed line must be installed in the cooling tower system to prevent build-up of impurities in the recirculated water.
 (2) Do not use catalog drawings for certified prints. Dimensions and weights are subject to change.
 (3) Adequate spacing must be allowed for access to the cooling tower. Refer to EVAPCO's Equipment Layout Manual.
 (4) Nominal Tonnage is based on 3 gpm per ton at 95 degree entering water temperature, 85 degree leaving water temperature, and 78 degree wet-bulb temperature.

◇ Outlet connection extends beyond bottom flange.
 † Height includes fan guard which ships factory mounted.

◆ Heaviest section is upper section.

Models: AT/UT/USS 212-2128 to 212-4N28

Two-Cell Cooling Towers

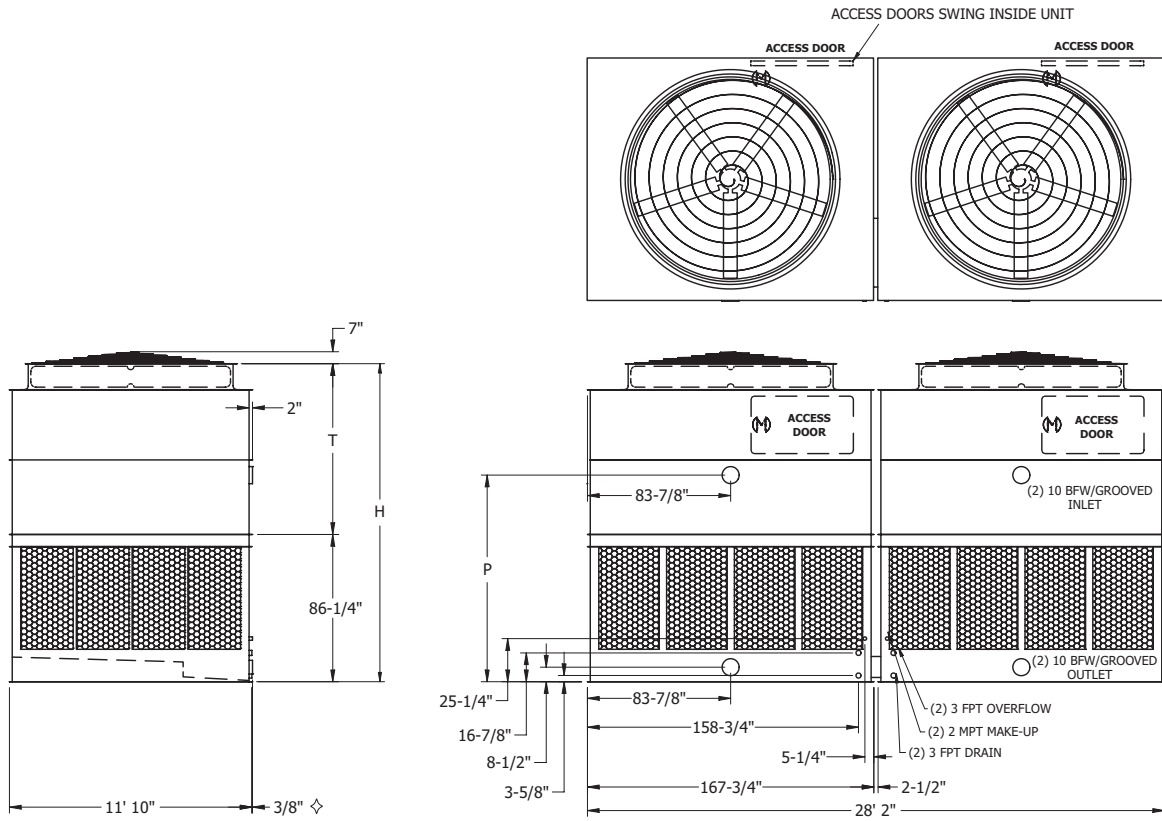

Model No.	Nominal Tonnage	WEIGHTS (LBS)			Fan Motor (HP)	Air Flow (CFM)	DIMENSIONS		
		Shipping	Operating	Heaviest Section†			H†	T†	P
AT 212-2128	598	16,820	31,480	5,360	(2) 10	155,600	15' 6-1/4"	8' 4"	10' 1"
AT 212-2J28	717	16,960	31,620	5,430	(2) 15	176,900	15' 6-1/4"	8' 4"	10' 1"
AT 212-2K28	787	17,080	31,740	5,490	(2) 20	194,000	15' 6-1/4"	8' 4"	10' 1"
AT 212-2L28	850	17,200	31,860	5,550	(2) 25	208,200	15' 6-1/4"	8' 4"	10' 1"
AT 212-2M28	900	17,340	32,000	5,620	(2) 30	220,700	15' 6-1/4"	8' 4"	10' 1"
AT 212-3I28	687	18,140	32,800	6,020	(2) 10	153,200	16' 6-1/4"	9' 4"	11' 1"
AT 212-3J28	810	18,280	32,940	6,090	(2) 15	174,000	16' 6-1/4"	9' 4"	11' 1"
AT 212-3K28	877	18,400	33,060	6,150	(2) 20	190,700	16' 6-1/4"	9' 4"	11' 1"
AT 212-3L28	942	18,520	33,180	6,210	(2) 25	204,500	16' 6-1/4"	9' 4"	11' 1"
AT 212-3M28	1,002	18,660	33,320	6,280	(2) 30	216,500	16' 6-1/4"	9' 4"	11' 1"
AT 212-3N28	1,097	19,180	33,840	6,540	(2) 40	237,100	16' 6-1/4"	9' 4"	11' 1"
AT 212-4I28	741	19,180	33,840	6,540	(2) 10	150,600	17' 6-1/4"	10' 4"	12' 1"
AT 212-4J28	853	19,320	33,980	6,610	(2) 15	171,200	17' 6-1/4"	10' 4"	12' 1"
AT 212-4K28	921	19,440	34,100	6,670	(2) 20	187,600	17' 6-1/4"	10' 4"	12' 1"
AT 212-4L28	987	19,560	34,220	6,730	(2) 25	201,200	17' 6-1/4"	10' 4"	12' 1"
AT 212-4M28	1,049	19,700	34,360	6,800	(2) 30	213,000	17' 6-1/4"	10' 4"	12' 1"
AT 212-4N28	1,147	20,220	34,880	7,060	(2) 40	232,900	17' 6-1/4"	10' 4"	12' 1"
SLSF Addition		2,400	2,400	1,200			1' 9-1/2"	1' 9-1/2"	

- NOTE: (1) An adequately sized bleed line must be installed in the cooling tower system to prevent build-up of impurities in the recirculated water.
 (2) Do not use catalog drawings for certified prints. Dimensions and weights are subject to change.
 (3) Adequate spacing must be allowed for access to the cooling tower. Refer to EVAPCO's Equipment Layout Manual.
 (4) Nominal Tonnage is based on 3 gpm per ton at 95 degree entering water temperature, 85 degree leaving water temperature, and 78 degree wet-bulb temperature.

◇ Outlet connection extends beyond bottom flange.
 † Height includes fan guard which ships factory mounted.

◆ Heaviest section is upper section.

Models: AT/UT/USS 312-2I42 to 312-4N42

Three-Cell Cooling Towers

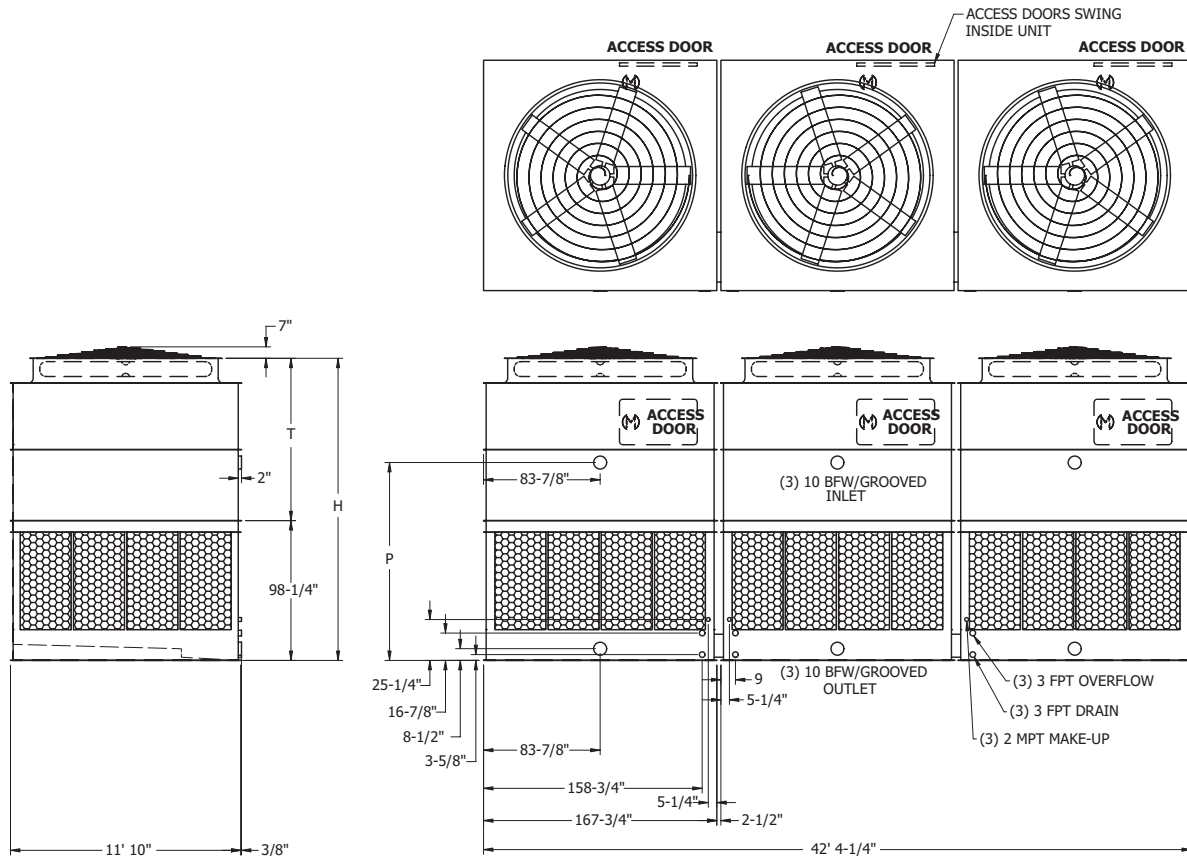

Model No.	Nominal Tonnage	WEIGHTS (LBS)			Fan Motor (HP)	Air Flow (CFM)	DIMENSIONS		
		Shipping	Operating	Heaviest Section†			H†	T†	P
AT 312-2I42	910	25,560	47,550	5,360	(3) 10	235,500	16' 6-1/4"	8' 4"	11' 1"
AT 312-2J42	1,091	25,770	47,760	5,430	(3) 15	267,800	16' 6-1/4"	8' 4"	11' 1"
AT 312-2K42	1,195	25,950	47,940	5,490	(3) 20	293,600	16' 6-1/4"	8' 4"	11' 1"
AT 312-2L42	1,289	26,130	48,120	5,550	(3) 25	315,200	16' 6-1/4"	8' 4"	11' 1"
AT 312-2M42	1,366	26,340	48,330	5,620	(3) 30	334,000	16' 6-1/4"	8' 4"	11' 1"
AT 312-3I42	1,045	27,540	49,530	6,020	(3) 10	231,900	17' 6-1/4"	9' 4"	12' 1"
AT 312-3J42	1,229	27,750	49,740	6,090	(3) 15	263,400	17' 6-1/4"	9' 4"	12' 1"
AT 312-3K42	1,330	27,930	49,920	6,150	(3) 20	288,500	17' 6-1/4"	9' 4"	12' 1"
AT 312-3L42	1,428	28,110	50,100	6,210	(3) 25	309,500	17' 6-1/4"	9' 4"	12' 1"
AT 312-3M42	1,519	28,320	50,310	6,280	(3) 30	327,600	17' 6-1/4"	9' 4"	12' 1"
AT 312-3N42	1,662	29,100	51,090	6,540	(3) 40	358,900	17' 6-1/4"	9' 4"	12' 1"
AT 312-4I42	1,123	29,100	51,090	6,540	(3) 10	227,900	18' 6-1/4"	10' 4"	13' 1"
AT 312-4J42	1,293	29,310	51,300	6,610	(3) 15	259,100	18' 6-1/4"	10' 4"	13' 1"
AT 312-4K42	1,395	29,490	51,480	6,670	(3) 20	284,000	18' 6-1/4"	10' 4"	13' 1"
AT 312-4L42	1,495	29,670	51,660	6,730	(3) 25	304,600	18' 6-1/4"	10' 4"	13' 1"
AT 312-4M42	1,589	29,880	51,870	6,800	(3) 30	322,400	18' 6-1/4"	10' 4"	13' 1"
AT 312-4N42	1,738	30,660	52,650	7,060	(3) 40	352,500	18' 6-1/4"	10' 4"	13' 1"
SLSF Addition		2,400	2,400	1,200			1' 9-1/2"	1' 9-1/2"	

- NOTE: (1) An adequately sized bleed line must be installed in the cooling tower system to prevent build-up of impurities in the recirculated water.
 (2) Do not use catalog drawings for certified prints. Dimensions and weights are subject to change.
 (3) Adequate spacing must be allowed for access to the cooling tower. Refer to EVAPCO's Equipment Layout Manual.
 (4) Nominal Tonnage is based on 3 gpm per ton at 95 degree entering water temperature, 85 degree leaving water temperature, and 78 degree wet-bulb temperature.

◇ Outlet connection extends beyond bottom flange.
 † Height includes fan guard which ships factory mounted.

◆ Heaviest section is upper section.

Models: AT/UT/USS 424-2I28 to 424-4N28

Four-Cell Cooling Towers

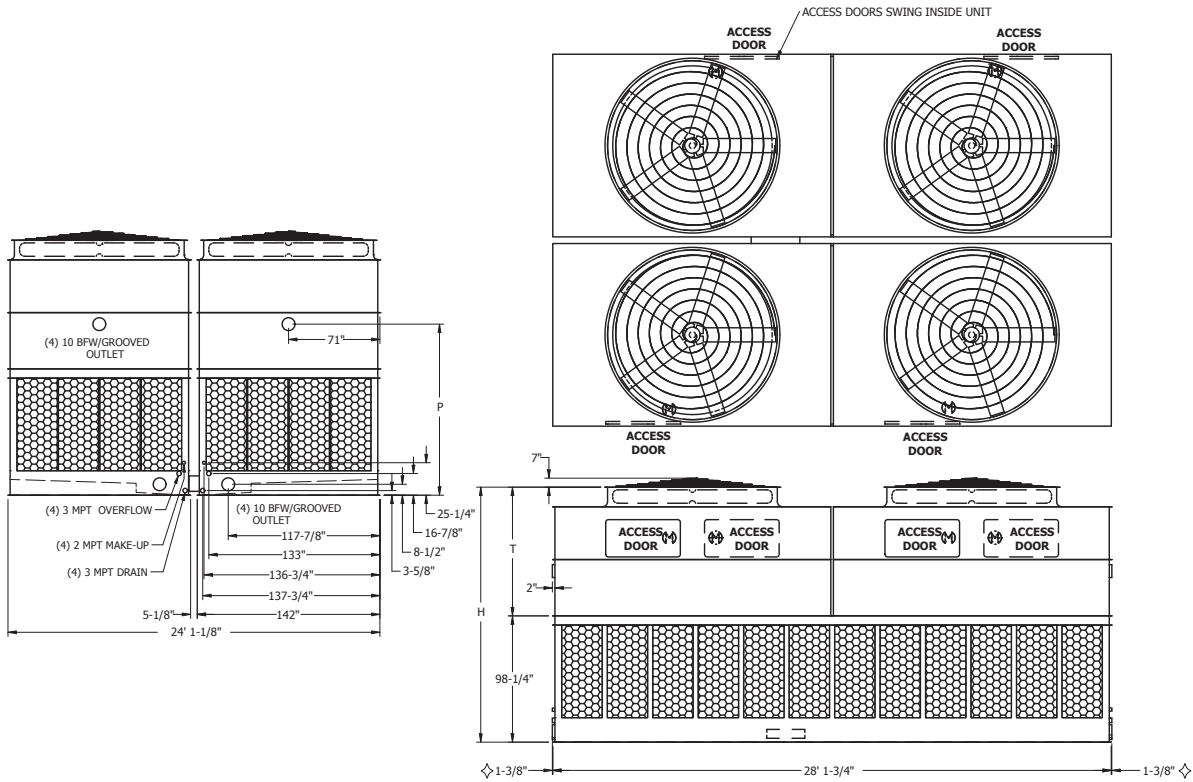

Model No.	Nominal Tonnage	WEIGHTS (LBS)			Fan Motor (HP)	Air Flow (CFM)	DIMENSIONS		
		Shipping	Operating	Heaviest Section†			H†	T†	P
AT 424-2I28	1,159	34,260	63,160	6,550	(4) 10	299,400	16' 6-1/4"	8' 4"	11' 1"
AT 424-2J28	1,405	34,820	63,720	6,550	(4) 15	340,300	16' 6-1/4"	8' 4"	11' 1"
AT 424-2K28	1,564	35,060	63,960	6,550	(4) 20	372,900	16' 6-1/4"	8' 4"	11' 1"
AT 424-2L28	1,689	35,300	64,200	6,550	(4) 25	400,300	16' 6-1/4"	8' 4"	11' 1"
AT 424-2M28	1,838	35,580	64,480	6,550	(4) 30	423,700	16' 6-1/4"	8' 4"	11' 1"
AT 424-3I28	1,322	36,900	65,800	6,550	(4) 10	294,900	17' 6-1/4"	9' 4"	12' 1"
AT 424-3J28	1,563	37,460	66,360	6,550	(4) 15	335,100	17' 6-1/4"	9' 4"	12' 1"
AT 424-3K28	1,745	37,700	66,600	6,550	(4) 20	366,600	17' 6-1/4"	9' 4"	12' 1"
AT 424-3L28	1,873	37,940	66,840	6,550	(4) 25	393,200	17' 6-1/4"	9' 4"	12' 1"
AT 424-3M28	1,993	38,220	67,120	6,550	(4) 30	416,200	17' 6-1/4"	9' 4"	12' 1"
AT 424-3N28	2,199	39,260	68,160	6,550	(4) 40	455,600	17' 6-1/4"	9' 4"	12' 1"
AT 424-4I28	1,434	38,980	67,880	6,550	(4) 10	289,800	18' 6-1/4"	10' 4"	13' 1"
AT 424-4J28	1,654	39,540	68,440	6,610	(4) 15	329,600	18' 6-1/4"	10' 4"	13' 1"
AT 424-4K28	1,833	39,780	68,680	6,670	(4) 20	360,700	18' 6-1/4"	10' 4"	13' 1"
AT 424-4L28	1,965	40,020	68,920	6,730	(4) 25	386,900	18' 6-1/4"	10' 4"	13' 1"
AT 424-4M28	2,088	40,300	69,200	6,800	(4) 30	409,600	18' 6-1/4"	10' 4"	13' 1"
AT 424-4N28	2,283	41,340	70,240	7,060	(4) 40	447,900	18' 6-1/4"	10' 4"	13' 1"
SLSF Addition		4,800	4,800	1,200			1' 9-1/2"	1' 9-1/2"	

- NOTE: (1) An adequately sized bleed line must be installed in the cooling tower system to prevent build-up of impurities in the recirculated water.
 (2) Do not use catalog drawings for certified prints. Dimensions and weights are subject to change.
 (3) Adequate spacing must be allowed for access to the cooling tower. Refer to EVAPCO's Equipment Layout Manual.
 (4) Nominal Tonnage is based on 3 gpm per ton at 95 degree entering water temperature, 85 degree leaving water temperature, and 78 degree wet-bulb temperature.

◇ Outlet connection extends beyond bottom flange.
 † Height includes fan guard which ships factory mounted.

◆ L=Lower Section, U=Upper Section

Models: AT/UT/USS 112-2J18 to 112-4P18

One-Cell Cooling Towers

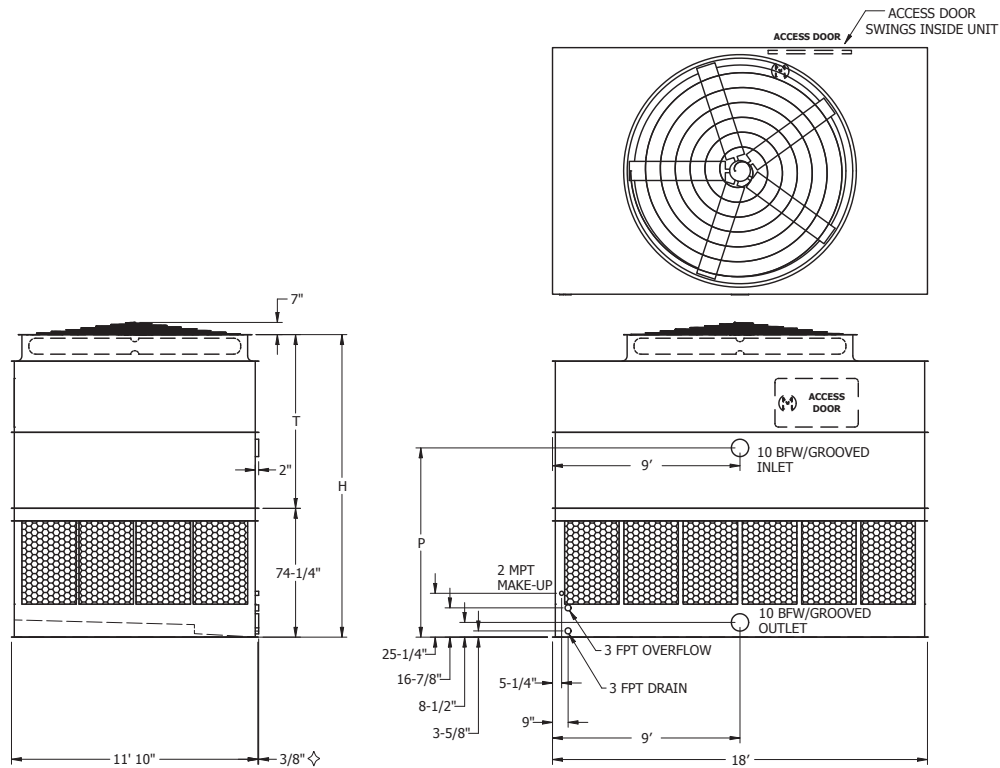

Model No.	Nominal Tonnage	WEIGHTS (LBS)			Fan Motor (HP)	Air Flow (CFM)	DIMENSIONS		
		Shipping	Operating	Heaviest Section†			H†	T†	P
AT 112-2J18	439	10,600	19,870	6,700	15	110,100	14' 6-1/4"	8' 4"	9' 1"
AT 112-2K18	497	10,660	19,930	6,760	20	120,600	14' 6-1/4"	8' 4"	9' 1"
AT 112-2L18	525	10,710	19,980	6,810	25	129,600	14' 6-1/4"	8' 4"	9' 1"
AT 112-2M18	554	10,820	20,090	6,920	30	137,400	14' 6-1/4"	8' 4"	9' 1"
AT 112-2N18	610	11,080	20,350	7,180	40	150,500	14' 6-1/4"	8' 4"	9' 1"
AT 112-3J18	488	11,380	20,650	7,480	15	108,500	15' 6-1/4"	9' 4"	10' 1"
AT 112-3K18	546	11,440	20,710	7,540	20	118,700	15' 6-1/4"	9' 4"	10' 1"
AT 112-3L18	581	11,490	20,760	7,590	25	127,400	15' 6-1/4"	9' 4"	10' 1"
AT 112-3M18	614	11,600	20,870	7,700	30	134,900	15' 6-1/4"	9' 4"	10' 1"
AT 112-3N18	675	11,860	21,130	7,960	40	147,600	15' 6-1/4"	9' 4"	10' 1"
AT 112-3O18	724	11,920	21,190	8,020	50	158,500	15' 6-1/4"	9' 4"	10' 1"
AT 112-4J18	518	12,120	21,390	8,220	15	106,700	16' 6-1/4"	10' 4"	11' 1"
AT 112-4K18	572	12,180	21,450	8,280	20	116,800	16' 6-1/4"	10' 4"	11' 1"
AT 112-4L18	606	12,230	21,500	8,330	25	125,400	16' 6-1/4"	10' 4"	11' 1"
AT 112-4M18	642	12,340	21,610	8,440	30	132,800	16' 6-1/4"	10' 4"	11' 1"
AT 112-4N18	705	12,600	21,870	8,700	40	145,200	16' 6-1/4"	10' 4"	11' 1"
AT 112-4O18	757	12,660	21,930	8,760	50	155,600	16' 6-1/4"	10' 4"	11' 1"
AT 112-4P18	785	12,770	22,040	8,870	60	164,900	16' 6-1/4"	10' 4"	11' 1"
SLSF Addition		1,200	1,200	1,200			1' 3-1/2"	1' 3-1/2"	

- NOTE: (1) An adequately sized bleed line must be installed in the cooling tower system to prevent build-up of impurities in the recirculated water.
 (2) Do not use catalog drawings for certified prints. Dimensions and weights are subject to change.
 (3) Adequate spacing must be allowed for access to the cooling tower. Refer to EVAPCO's Equipment Layout Manual.
 (4) Nominal Tonnage is based on 3 gpm per ton at 95 degree entering water temperature, 85 degree leaving water temperature, and 78 degree wet-bulb temperature.
 (5) This box size is available in a dual fan/cell configuration.

◇ Outlet connection extends beyond bottom flange.
 † Height includes fan guard which ships factory mounted.

◆ Heaviest section is upper section.

Models: AT/UT/USS 224-2J18 to 224-4P18

Two-Cell Cooling Towers

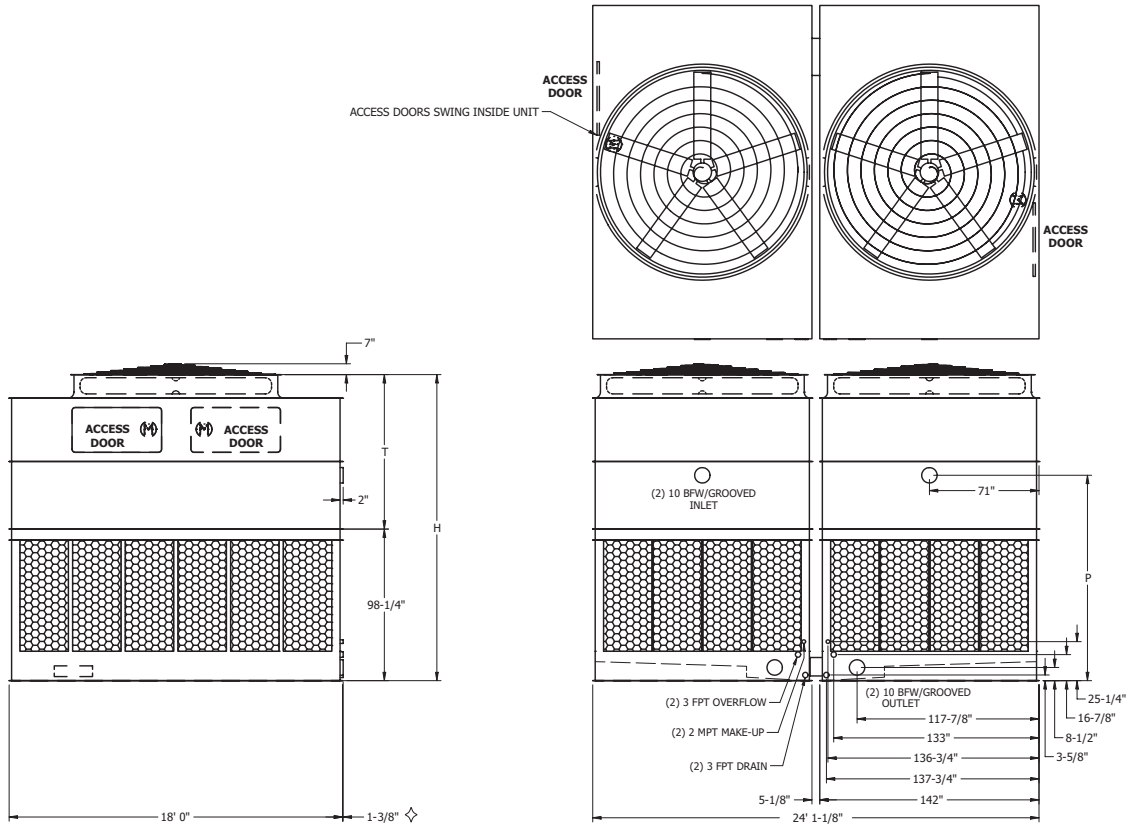

Model No.	Nominal Tonnage	WEIGHTS (LBS)			Fan Motor (HP)	Air Flow (CFM)	DIMENSIONS		
		Shipping	Operating	Heaviest Section†			H†	T†	P
AT 224-2J18	877	22,160	40,700	6,700	(2) 15	219,400	16' 6-1/4"	8' 4"	11' 1"
AT 224-2K18	994	22,280	40,820	6,760	(2) 20	240,300	16' 6-1/4"	8' 4"	11' 1"
AT 224-2L18	1,051	22,380	40,920	6,810	(2) 25	258,200	16' 6-1/4"	8' 4"	11' 1"
AT 224-2M18	1,107	22,600	41,140	6,920	(2) 30	273,700	16' 6-1/4"	8' 4"	11' 1"
AT 224-2N18	1,219	23,120	41,660	7,180	(2) 40	299,800	16' 6-1/4"	8' 4"	11' 1"
AT 224-3J18	977	23,720	42,260	7,480	(2) 15	216,100	17' 6-1/4"	9' 4"	12' 1"
AT 224-3K18	1,092	23,840	42,380	7,540	(2) 20	236,500	17' 6-1/4"	9' 4"	12' 1"
AT 224-3L18	1,161	23,940	42,480	7,590	(2) 25	253,800	17' 6-1/4"	9' 4"	12' 1"
AT 224-3M18	1,227	24,160	42,700	7,700	(2) 30	268,800	17' 6-1/4"	9' 4"	12' 1"
AT 224-3N18	1,350	24,680	43,220	7,960	(2) 40	294,100	17' 6-1/4"	9' 4"	12' 1"
AT 224-3O18	1,448	24,800	43,340	8,020	(2) 50	315,700	17' 6-1/4"	9' 4"	12' 1"
AT 224-4J18	1,035	25,200	43,740	8,220	(2) 15	212,500	18' 6-1/4"	10' 4"	13' 1"
AT 224-4K18	1,145	25,320	43,860	8,280	(2) 20	232,700	18' 6-1/4"	10' 4"	13' 1"
AT 224-4L18	1,213	25,420	43,960	8,330	(2) 25	249,800	18' 6-1/4"	10' 4"	13' 1"
AT 224-4M18	1,283	25,640	44,180	8,440	(2) 30	264,500	18' 6-1/4"	10' 4"	13' 1"
AT 224-4N18	1,409	26,160	44,700	8,700	(2) 40	289,300	18' 6-1/4"	10' 4"	13' 1"
AT 224-4O18	1,513	26,280	44,820	8,760	(2) 50	310,000	18' 6-1/4"	10' 4"	13' 1"
AT 224-4P18	1,570	26,500	45,040	8,870	(2) 60	328,500	18' 6-1/4"	10' 4"	13' 1"
SLSF Addition		2,400	2,400	1,200			1' 3-1/2"	1' 3-1/2"	

- NOTE: (1) An adequately sized bleed line must be installed in the cooling tower system to prevent build-up of impurities in the recirculated water.
 (2) Do not use catalog drawings for certified prints. Dimensions and weights are subject to change.
 (3) Adequate spacing must be allowed for access to the cooling tower. Refer to EVAPCO's Equipment Layout Manual.
 (4) Nominal Tonnage is based on 3 gpm per ton at 95 degree entering water temperature, 85 degree leaving water temperature, and 78 degree wet-bulb temperature.
 (5) This box size is available in a dual fan/cell configuration.

◇ Outlet connection extends beyond bottom flange.
 † Height includes fan guard which ships factory mounted.

◆ Heaviest section is upper section.

Models: AT/UT/USS 212-2J36 to 212-4P36

Two-Cell Cooling Towers

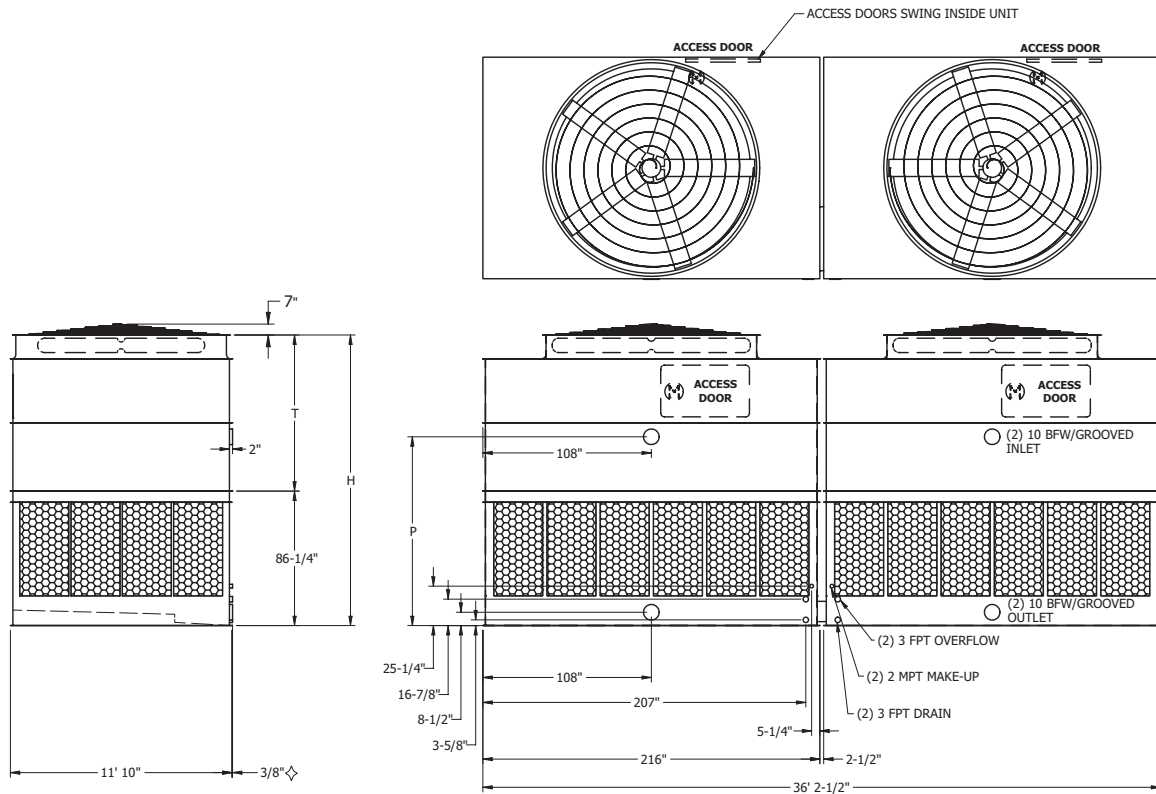

Model No.	Nominal Tonnage	WEIGHTS (LBS)			Fan Motor (HP)	Air Flow (CFM)	DIMENSIONS		
		Shipping	Operating	Heaviest Section♦			H†	T†	P
AT 212-2J36	877	21,460	40,000	6,700	(2) 15	220,200	15' 6-1/4"	8' 4"	10' 1"
AT 212-2K36	994	21,580	40,120	6,760	(2) 20	241,200	15' 6-1/4"	8' 4"	10' 1"
AT 212-2L36	1,051	21,680	40,220	6,810	(2) 25	259,200	15' 6-1/4"	8' 4"	10' 1"
AT 212-2M36	1,107	21,900	40,440	6,920	(2) 30	274,700	15' 6-1/4"	8' 4"	10' 1"
AT 212-2N36	1,219	22,420	40,960	7,180	(2) 40	300,900	15' 6-1/4"	8' 4"	10' 1"
AT 212-3J36	977	23,020	41,560	7,480	(2) 15	216,900	16' 6-1/4"	9' 4"	11' 1"
AT 212-3K36	1,092	23,140	41,680	7,540	(2) 20	237,300	16' 6-1/4"	9' 4"	11' 1"
AT 212-3L36	1,161	23,240	41,780	7,590	(2) 40	254,700	16' 6-1/4"	9' 4"	11' 1"
AT 212-3M36	1,227	23,460	42,000	7,700	(2) 50	269,800	16' 6-1/4"	9' 4"	11' 1"
AT 212-3N36	1,350	23,980	42,520	7,960	(2) 30	295,200	16' 6-1/4"	9' 4"	11' 1"
AT 212-3O36	1,448	24,100	42,640	8,020	(2) 25	316,900	16' 6-1/4"	9' 4"	11' 1"
AT 212-4J36	1,035	24,500	43,040	8,220	(2) 15	213,300	17' 6-1/4"	10' 4"	12' 1"
AT 212-4K36	1,145	24,620	43,160	8,280	(2) 20	233,600	17' 6-1/4"	10' 4"	12' 1"
AT 212-4L36	1,213	24,720	43,260	8,330	(2) 25	250,800	17' 6-1/4"	10' 4"	12' 1"
AT 212-4M36	1,283	24,940	43,480	8,440	(2) 30	265,500	17' 6-1/4"	10' 4"	12' 1"
AT 212-4N36	1,409	25,460	44,000	8,700	(2) 40	290,400	17' 6-1/4"	10' 4"	12' 1"
AT 212-4O36	1,513	25,580	44,120	8,760	(2) 50	311,200	17' 6-1/4"	10' 4"	12' 1"
AT 212-4P36	1,570	25,800	44,340	8,870	(2) 60	329,700	17' 6-1/4"	10' 4"	12' 1"
SLSF Addition		2,400	2,400	1,200			1' 3-1/2"	1' 3-1/2"	

- NOTE: (1) An adequately sized bleed line must be installed in the cooling tower system to prevent build-up of impurities in the recirculated water.
 (2) Do not use catalog drawings for certified prints. Dimensions and weights are subject to change.
 (3) Adequate spacing must be allowed for access to the cooling tower. Refer to EVAPCO's Equipment Layout Manual.
 (4) Nominal Tonnage is based on 3 gpm per ton at 95 degree entering water temperature, 85 degree leaving water temperature, and 78 degree wet-bulb temperature.
 (5) This box size is available in a dual fan/cell configuration.

◇ Outlet connection extends beyond bottom flange.
 † Height includes fan guard which ships factory mounted.

♦ Heaviest section is upper section.

Models: AT/UT/USS 312-2J54 to 312-4P54

Three-Cell Cooling Towers

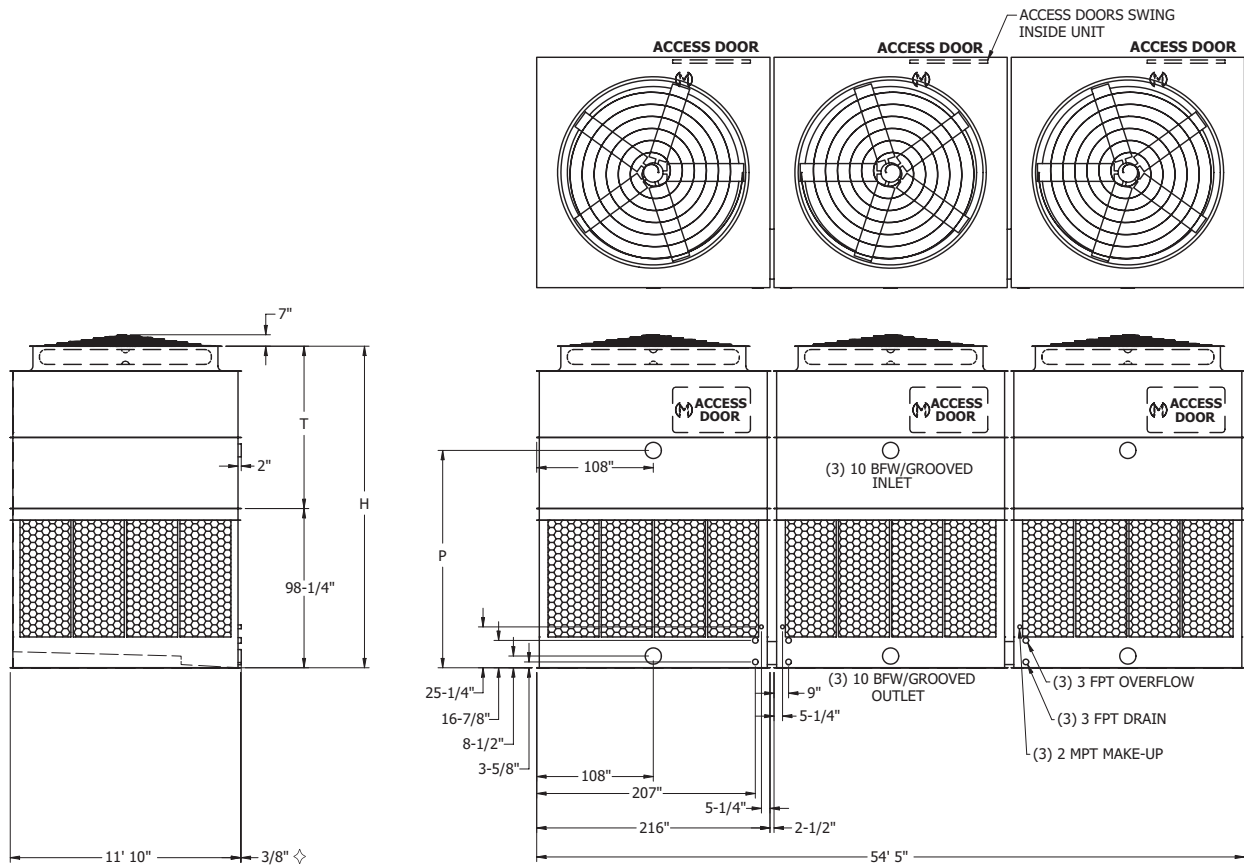

Model No.	Nominal Tonnage	WEIGHTS (LBS)			Fan Motor (HP)	Air Flow (CFM)	DIMENSIONS		
		Shipping	Operating	Heaviest Section†			H†	T†	P
AT 312-2J54	1,324	32,640	60,450	6,700	(3) 15	330,500	16' 6-1/4"	8' 4"	11' 1"
AT 312-2K54	1,499	32,820	60,630	6,760	(3) 20	362,000	16' 6-1/4"	8' 4"	11' 1"
AT 312-2L54	1,586	32,970	60,780	6,810	(3) 25	389,000	16' 6-1/4"	8' 4"	11' 1"
AT 312-2M54	1,670	33,300	61,110	6,920	(3) 30	412,300	16' 6-1/4"	8' 4"	11' 1"
AT 312-2N54	1,840	34,080	61,890	7,180	(3) 40	451,700	16' 6-1/4"	8' 4"	11' 1"
AT 312-3J54	1,473	34,980	62,790	7,480	(3) 15	325,600	17' 6-1/4"	9' 4"	12' 1"
AT 312-3K54	1,648	35,160	62,970	7,540	(3) 20	356,200	17' 6-1/4"	9' 4"	12' 1"
AT 312-3L54	1,752	35,310	63,120	7,590	(3) 25	382,300	17' 6-1/4"	9' 4"	12' 1"
AT 312-3M54	1,851	35,640	63,450	7,700	(3) 30	404,900	17' 6-1/4"	9' 4"	12' 1"
AT 312-3N54	2,036	36,420	64,230	7,960	(3) 40	443,100	17' 6-1/4"	9' 4"	12' 1"
AT 312-3O54	2,182	36,600	64,410	8,020	(3) 50	475,700	17' 6-1/4"	9' 4"	12' 1"
AT 312-4J54	1,560	37,200	65,010	8,220	(3) 15	320,200	18' 6-1/4"	10' 4"	13' 1"
AT 312-4K54	1,725	37,380	65,190	8,280	(3) 20	350,500	18' 6-1/4"	10' 4"	13' 1"
AT 312-4L54	1,828	37,530	65,340	8,330	(3) 25	376,300	18' 6-1/4"	10' 4"	13' 1"
AT 312-4M54	1,935	37,860	65,670	8,440	(3) 30	398,500	18' 6-1/4"	10' 4"	13' 1"
AT 312-4N54	2,124	38,640	66,450	8,700	(3) 40	435,800	18' 6-1/4"	10' 4"	13' 1"
AT 312-4O54	2,281	38,820	66,630	8,760	(3) 50	467,000	18' 6-1/4"	10' 4"	13' 1"
AT 312-4P54	2,367	39,150	66,960	8,870	(3) 60	494,700	18' 6-1/4"	10' 4"	13' 1"
SLSF Addition		3,600	3,600	1,200			1' 3-1/2"	1' 3-1/2"	

- NOTE: (1) An adequately sized bleed line must be installed in the cooling tower system to prevent build-up of impurities in the recirculated water.
 (2) Do not use catalog drawings for certified prints. Dimensions and weights are subject to change.
 (3) Adequate spacing must be allowed for access to the cooling tower. Refer to EVAPCO's Equipment Layout Manual.
 (4) Nominal Tonnage is based on 3 gpm per ton at 95 degree entering water temperature, 85 degree leaving water temperature, and 78 degree wet-bulb temperature.
 (5) This box size is available in a dual fan/cell configuration.

◇ Outlet connection extends beyond bottom flange.
 † Height includes fan guard which ships factory mounted.

◆ Heaviest section is upper section.

Models: AT/UT/USS 424-2J36 to 424-4P36

Four-Cell Cooling Towers

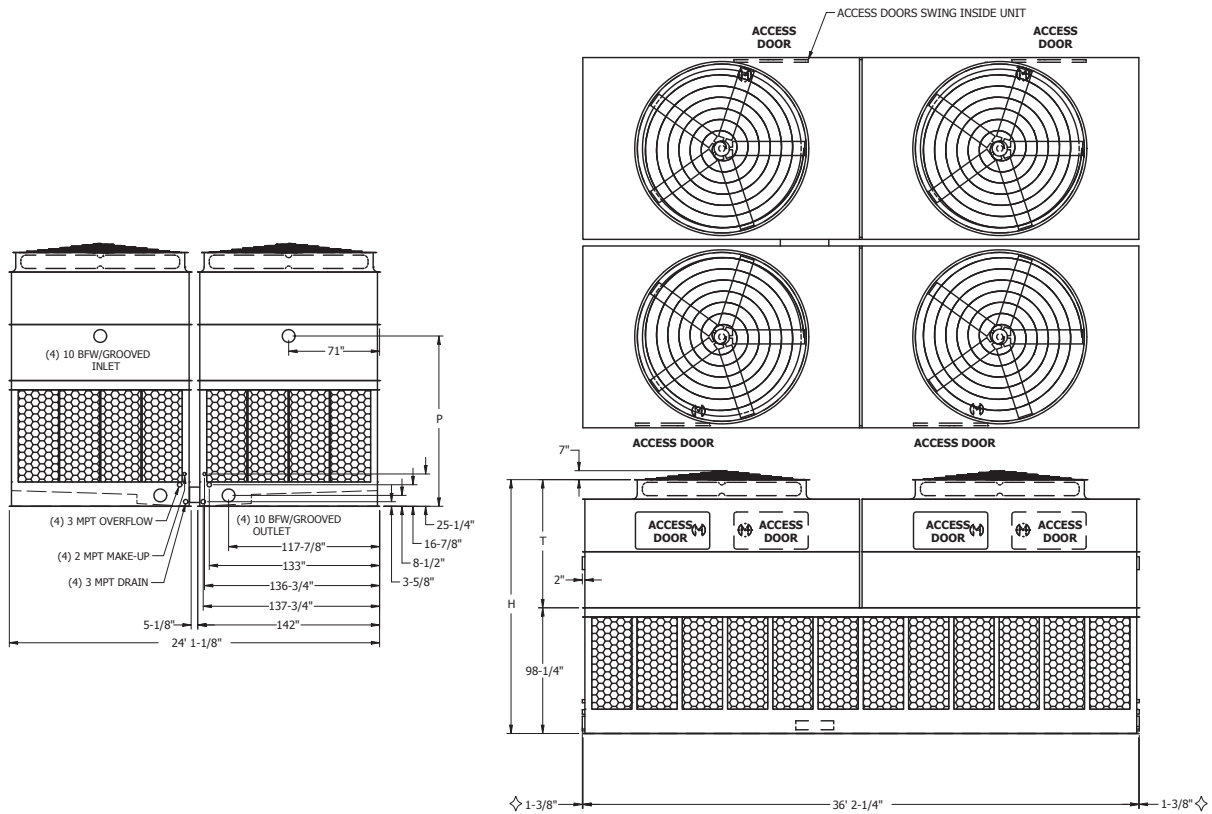

Model No.	Nominal Tonnage	WEIGHTS (LBS)			Fan Motor (HP)	Air Flow (CFM)	DIMENSIONS		
		Shipping	Operating	Heaviest Section [†]			H [†]	T [†]	P
AT 424-2J36	1,687	43,840	80,540	8,520	(4) 15	423,100	16' 6-1/4"	8' 4"	11' 1"
AT 424-2K36	1,914	44,080	80,780	8,520	(4) 20	463,300	16' 6-1/4"	8' 4"	11' 1"
AT 424-2L36	2,023	44,280	80,980	8,520	(4) 25	498,000	16' 6-1/4"	8' 4"	11' 1"
AT 424-2M36	2,133	44,720	81,420	8,520	(4) 30	527,900	16' 6-1/4"	8' 4"	11' 1"
AT 424-2N36	2,350	45,760	82,460	8,520	(4) 40	578,400	16' 6-1/4"	8' 4"	11' 1"
AT 424-3J36	1,883	46,960	83,660	8,520	(4) 15	416,900	17' 6-1/4"	9' 4"	12' 1"
AT 424-3K36	2,108	47,200	83,900	8,520	(4) 20	456,200	17' 6-1/4"	9' 4"	12' 1"
AT 424-3L36	2,246	47,400	84,100	8,520	(4) 25	489,600	17' 6-1/4"	9' 4"	12' 1"
AT 424-3M36	2,373	47,840	84,540	8,520	(4) 30	518,600	17' 6-1/4"	9' 4"	12' 1"
AT 424-3N36	2,614	48,880	85,580	8,520	(4) 40	567,400	17' 6-1/4"	9' 4"	12' 1"
AT 424-3O36	2,806	49,120	85,820	8,520	(4) 50	608,800	17' 6-1/4"	9' 4"	12' 1"
AT 424-4J36	2,005	49,920	86,620	8,520	(4) 15	409,800	18' 6-1/4"	10' 4"	13' 1"
AT 424-4K36	2,221	50,160	86,860	8,520	(4) 20	448,800	18' 6-1/4"	10' 4"	13' 1"
AT 424-4L36	2,353	50,360	87,060	8,520	(4) 25	481,900	18' 6-1/4"	10' 4"	13' 1"
AT 424-4M36	2,491	50,800	87,500	8,520	(4) 30	510,300	18' 6-1/4"	10' 4"	13' 1"
AT 424-4N36	2,736	51,840	88,540	8,700	(4) 40	558,300	18' 6-1/4"	10' 4"	13' 1"
AT 424-4O36	2,938	52,080	88,780	8,760	(4) 50	598,300	18' 6-1/4"	10' 4"	13' 1"
AT 424-4P36	3,049	52,520	89,220	8,870	(4) 60	633,900	18' 6-1/4"	10' 4"	13' 1"
SLSF Addition		4,800	4,800	1,200			1' 3-1/2"	1' 3-1/2"	

- NOTE: (1) An adequately sized bleed line must be installed in the cooling tower system to prevent build-up of impurities in the recirculated water.
 (2) Do not use catalog drawings for certified prints. Dimensions and weights are subject to change.
 (3) Adequate spacing must be allowed for access to the cooling tower. Refer to EVAPCO's Equipment Layout Manual.
 (4) Nominal Tonnage is based on 3 gpm per ton at 95 degree entering water temperature, 85 degree leaving water temperature, and 78 degree wet-bulb temperature.
 (5) This box size is available in a dual fan/cell configuration.

◇ Outlet connection extends beyond bottom flange.
 † Height includes fan guard which ships factory mounted.

◆ L=Lower Section, U=Upper Section

Models: AT/UT/USS 112-2K20 to 112-4P20

One-Cell Cooling Towers

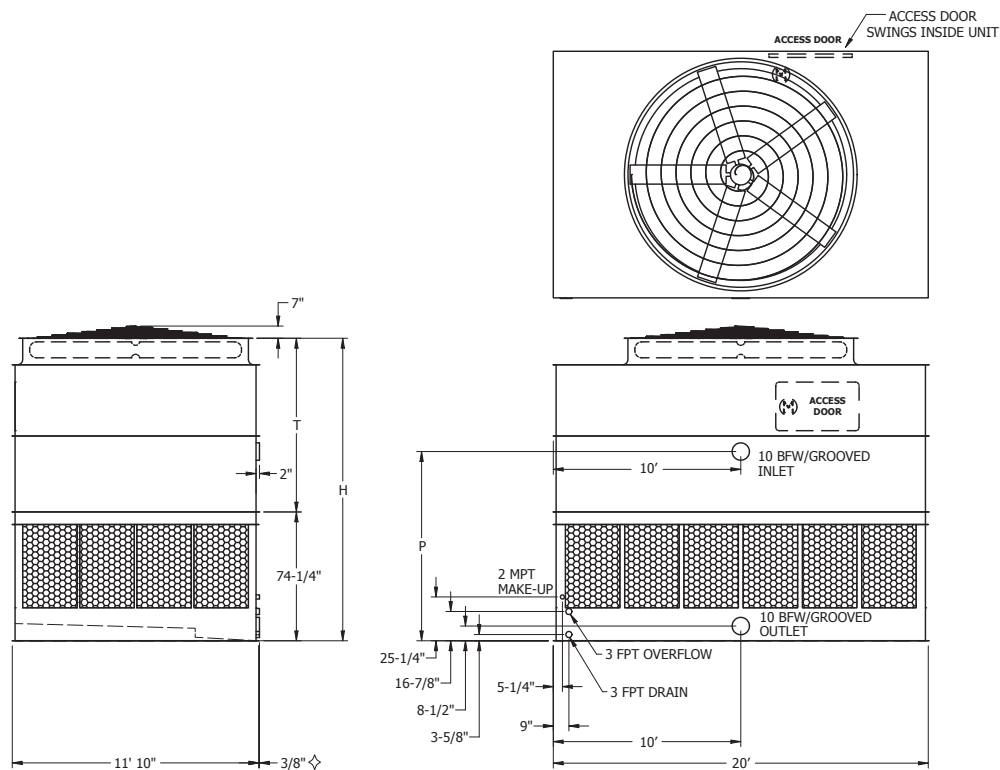

Model No.	Nominal Tonnage	WEIGHTS (LBS)			Fan Motor (HP)	Air Flow (CFM)	DIMENSIONS		
		Shipping	Operating	Heaviest Section†			H†	T†	P
AT 112-2K20	459	11,320	21,720	7,210	20	123,900	14' 6 1/4"	8' 4"	9' 1"
AT 112-2L20	506	11,370	21,770	7,260	25	133,000	14' 6 1/4"	8' 4"	9' 1"
AT 112-2M20	544	11,480	21,880	7,370	30	140,900	14' 6 1/4"	8' 4"	9' 1"
AT 112-2N20	625	11,740	22,140	7,630	40	154,100	14' 6 1/4"	8' 4"	9' 1"
AT 112-2O20	679	11,800	22,200	7,690	50	165,300	14' 6 1/4"	8' 4"	9' 1"
AT 112-3K20	536	12,050	22,450	7,940	20	121,800	15' 6 1/4"	9' 4"	10' 1"
AT 112-3L20	585	12,100	22,500	7,990	25	130,700	15' 6 1/4"	9' 4"	10' 1"
AT 112-3M20	623	12,210	22,610	8,100	30	138,300	15' 6 1/4"	9' 4"	10' 1"
AT 112-3N20	698	12,470	22,870	8,360	40	151,200	15' 6 1/4"	9' 4"	10' 1"
AT 112-3O20	757	12,530	22,930	8,420	50	162,100	15' 6 1/4"	9' 4"	10' 1"
AT 112-4K20	572	12,950	23,350	8,840	20	119,800	16' 6 1/4"	10' 4"	11' 1"
AT 112-4L20	618	13,000	23,400	8,890	25	128,500	16' 6 1/4"	10' 4"	11' 1"
AT 112-4M20	655	13,110	23,510	9,000	30	136,100	16' 6 1/4"	10' 4"	11' 1"
AT 112-4N20	728	13,370	23,770	9,260	40	148,800	16' 6 1/4"	10' 4"	11' 1"
AT 112-4O20	788	13,430	23,830	9,320	50	159,500	16' 6 1/4"	10' 4"	11' 1"
AT 112-4P20	817	13,540	23,940	9,430	60	169,000	16' 6 1/4"	10' 4"	11' 1"
SLSF Addition		1,200	1,200	1,200			1' 3-1/2"	1' 3-1/2"	

- NOTE: (1) An adequately sized bleed line must be installed in the cooling tower system to prevent build-up of impurities in the recirculated water.
 (2) Do not use catalog drawings for certified prints. Dimensions and weights are subject to change.
 (3) Adequate spacing must be allowed for access to the cooling tower. Refer to EVAPCO's Equipment Layout Manual.
 (4) Nominal Tonnage is based on 3 gpm per ton at 95 degree entering water temperature, 85 degree leaving water temperature, and 78 degree wet-bulb temperature.
 (5) This box size is available in a dual fan/cell configuration.

◇ Outlet connection extends beyond bottom flange.
 † Height includes fan guard which ships factory mounted.

◆ Heaviest section is upper section.

Models: AT/UT/USS 224-2K20 to 224-4P20

Two-Cell Cooling Towers

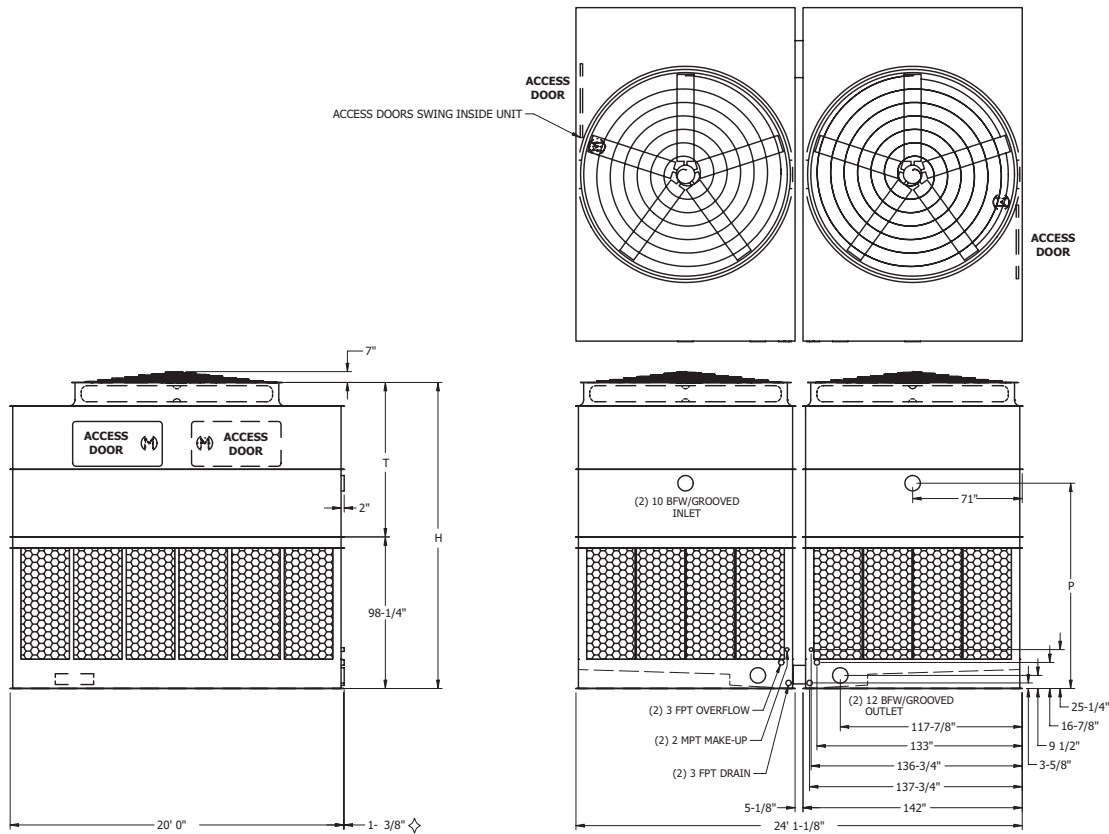

Model No.	Nominal Tonnage	Weights (LBS)			Fan Motor (HP)	Air Flow (CFM)	Dimensions		
		Shipping	Operating	Heaviest Section [‡]			H [†]	T [†]	P
AT 224-2K20	893	23,660	44,460	7,210	(2) 20	244,300	16' 6-1/4"	8' 4"	11' 1"
AT 224-2L20	986	23,760	44,560	7,260	(2) 25	262,200	16' 6-1/4"	8' 4"	11' 1"
AT 224-2M20	1,061	23,980	44,780	7,370	(2) 30	277,900	16' 6-1/4"	8' 4"	11' 1"
AT 224-2N20	1,220	24,500	45,300	7,630	(2) 40	304,000	16' 6-1/4"	8' 4"	11' 1"
AT 224-2O20	1,324	24,620	45,420	7,690	(2) 50	326,100	16' 6-1/4"	8' 4"	11' 1"
AT 224-3K20	1,046	25,120	45,920	7,940	(2) 20	240,300	17' 6-1/4"	9' 4"	12' 1"
AT 224-3L20	1,142	25,220	46,020	7,990	(2) 25	257,800	17' 6-1/4"	9' 4"	12' 1"
AT 224-3M20	1,219	25,440	46,240	8,100	(2) 30	272,900	17' 6-1/4"	9' 4"	12' 1"
AT 224-3N20	1,366	25,960	46,760	8,360	(2) 40	298,300	17' 6-1/4"	9' 4"	12' 1"
AT 224-3O20	1,482	26,080	46,880	8,420	(2) 50	319,800	17' 6-1/4"	9' 4"	12' 1"
AT 224-4K20	1,119	26,920	47,720	8,840	(2) 20	236,300	18' 6-1/4"	10' 4"	13' 1"
AT 224-4L20	1,210	27,020	47,820	8,890	(2) 25	253,500	18' 6-1/4"	10' 4"	13' 1"
AT 224-4M20	1,284	27,240	48,040	9,000	(2) 30	268,500	18' 6-1/4"	10' 4"	13' 1"
AT 224-4N20	1,428	27,760	48,560	9,260	(2) 40	293,700	18' 6-1/4"	10' 4"	13' 1"
AT 224-4O20	1,545	27,880	48,680	9,320	(2) 50	314,700	18' 6-1/4"	10' 4"	13' 1"
AT 224-4P20	1,603	28,100	48,900	9,430	(2) 60	333,500	18' 6-1/4"	10' 4"	13' 1"
SLSF Addition		2,400	2,400	1,200			1' 3-1/2"	1' 3-1/2"	

- NOTE: (1) An adequately sized bleed line must be installed in the cooling tower system to prevent build-up of impurities in the recirculated water.
 (2) Do not use catalog drawings for certified prints. Dimensions and weights are subject to change.
 (3) Adequate spacing must be allowed for access to the cooling tower. Refer to EVAPCO's Equipment Layout Manual.
 (4) Nominal Tonnage is based on 3 gpm per ton at 95 degree entering water temperature, 85 degree leaving water temperature, and 78 degree wet-bulb temperature.
 (5) This box size is available in a dual fan/cell configuration.

◇ Outlet connection extends beyond bottom flange.

‡ Heaviest section is upper section.

† Height includes fan guard which ships factory mounted.

Models: AT/UT/USS 212-2K40 to 212-4P40

Two-Cell Cooling Towers

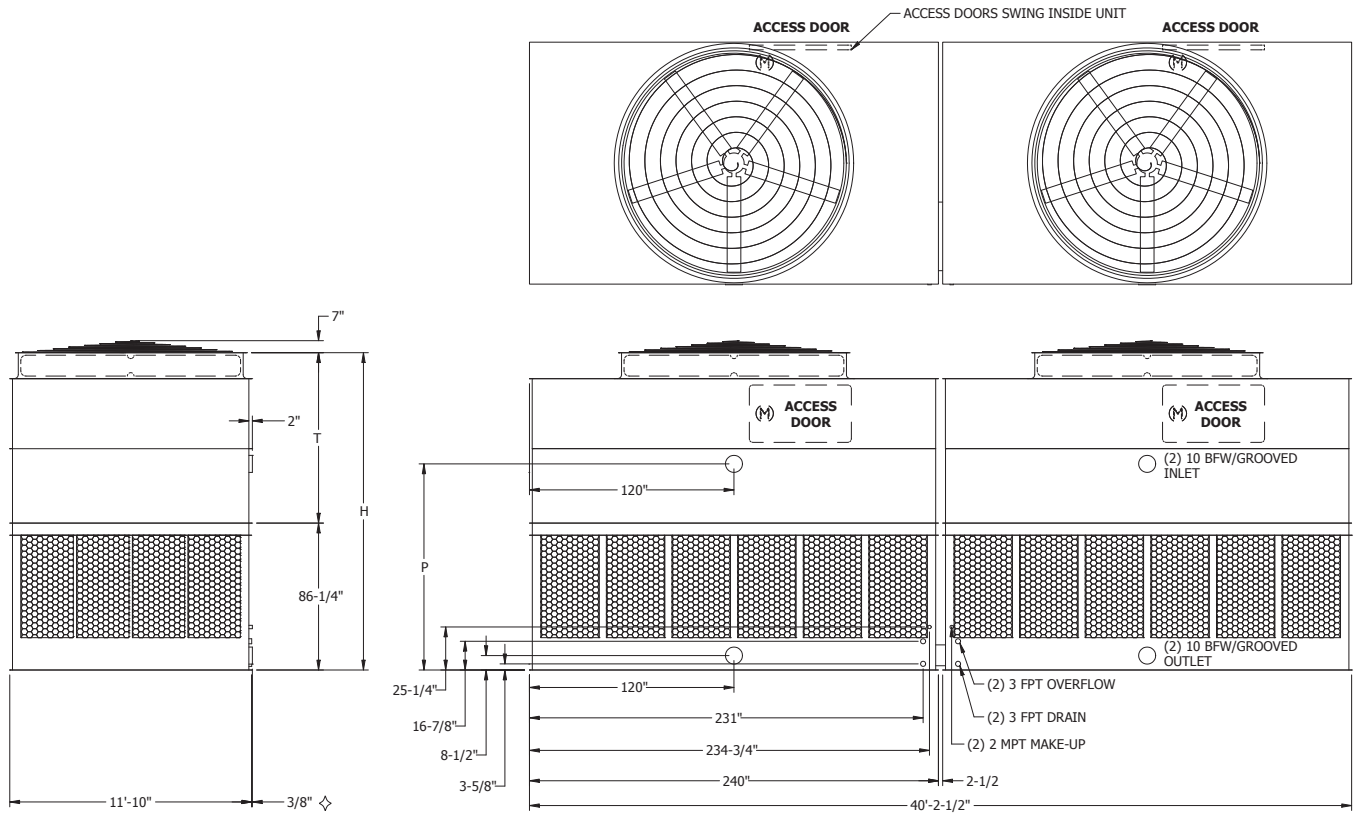

Model No.	Nominal Tonnage	WEIGHTS (LBS)			Fan Motor (HP)	Air Flow (CFM)	DIMENSIONS		
		Shipping	Operating	Heaviest Section†			H†	T†	P
AT 212-2K40	918	22,940	43,740	7,210	(2) 20	246,500	15' 6-1/2"	8' 4"	10' 1"
AT 212-2L40	1,013	23,040	43,840	7,260	(2) 25	264,600	15' 6-1/2"	8' 4"	10' 1"
AT 212-2M40	1,088	23,260	44,060	7,370	(2) 30	280,300	15' 6-1/2"	8' 4"	10' 1"
AT 212-2N40	1,250	23,780	44,580	7,630	(2) 40	306,600	15' 6-1/2"	8' 4"	10' 1"
AT 212-2O40	1,357	23,900	44,700	7,690	(2) 50	329,000	15' 6-1/2"	8' 4"	10' 1"
AT 212-3K40	1,073	24,400	45,200	7,940	(2) 20	242,400	16' 6-1/2"	9' 4"	11' 1"
AT 212-3L40	1,170	24,500	45,300	7,990	(2) 25	260,000	16' 6-1/2"	9' 4"	11' 1"
AT 212-3M40	1,246	24,720	45,520	8,100	(2) 30	275,300	16' 6-1/2"	9' 4"	11' 1"
AT 212-3N40	1,396	25,240	46,040	8,360	(2) 40	300,900	16' 6-1/2"	9' 4"	11' 1"
AT 212-3O40	1,515	25,360	46,160	8,420	(2) 50	322,600	16' 6-1/2"	9' 4"	11' 1"
AT 212-4K40	1,143	26,200	47,000	8,840	(2) 20	238,300	17' 6-1/2"	10' 4"	12' 1"
AT 212-4L40	1,235	26,300	47,100	8,890	(2) 25	255,700	17' 6-1/2"	10' 4"	12' 1"
AT 212-4M40	1,310	26,520	47,320	9,000	(2) 30	270,900	17' 6-1/2"	10' 4"	12' 1"
AT 212-4N40	1,457	27,040	47,840	9,260	(2) 40	296,200	17' 6-1/2"	10' 4"	12' 1"
AT 212-4O40	1,576	27,160	47,960	9,320	(2) 50	317,300	17' 6-1/2"	10' 4"	12' 1"
AT 212-4P40	1,635	27,380	48,180	9,430	(2) 60	336,300	17' 6-1/2"	10' 4"	12' 1"
SLSF Addition		2,400	2,400	1,200			1' 3-1/2"	1' 3-1/2"	

- NOTE: (1) An adequately sized bleed line must be installed in the cooling tower system to prevent build-up of impurities in the recirculated water.
(2) Do not use catalog drawings for certified prints. Dimensions and weights are subject to change.
(3) Adequate spacing must be allowed for access to the cooling tower. Refer to EVAPCO's Equipment Layout Manual.
(4) Nominal Tonnage is based on 3 gpm per ton at 95 degree entering water temperature, 85 degree leaving water temperature, and 78 degree wet-bulb temperature.
(5) This box size is available in a dual fan/cell configuration.

◇ Outlet connection extends beyond bottom flange.
† Height includes fan guard which ships factory mounted.

◆ Heaviest section is upper section.

Models: AT/UT/USS 312-2K60 to 312-4P60

Three-Cell Cooling Towers

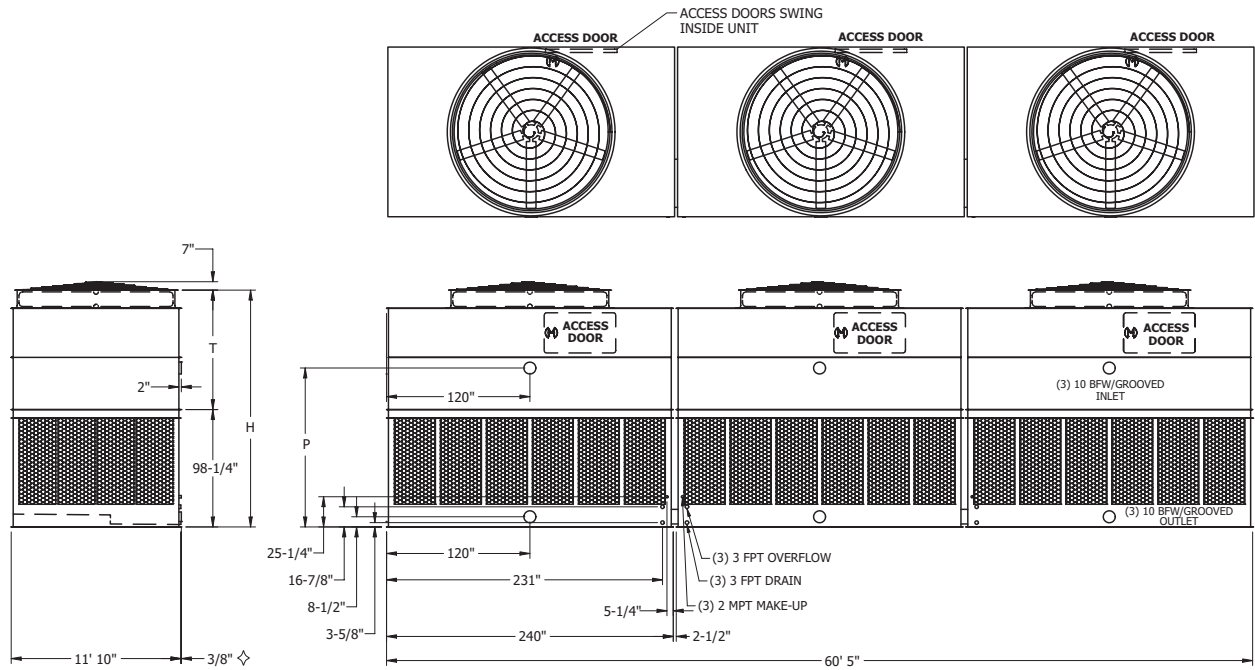

Model No.	Nominal Tonnage	WEIGHTS (LBS)			Fan Motor (HP)	Air Flow (CFM)	DIMENSIONS		
		Shipping	Operating	Heaviest Section†			H†	T†	P
AT 312-2K60	1,368	34,890	66,090	7,210	(3) 20	369,800	16' 6-1/4"	8' 4"	11' 1"
AT 312-2L60	1,508	35,040	66,240	7,260	(3) 25	396,900	16' 6-1/4"	8' 4"	11' 1"
AT 312-2M60	1,622	35,370	66,570	7,370	(3) 30	420,600	16' 6-1/4"	8' 4"	11' 1"
AT 312-2N60	1,865	36,150	67,350	7,630	(3) 40	460,000	16' 6-1/4"	8' 4"	11' 1"
AT 312-2O60	2,023	36,330	67,530	7,690	(3) 50	493,600	16' 6-1/4"	8' 4"	11' 1"
AT 312-3K60	1,600	37,080	68,280	7,940	(3) 20	363,700	17' 6-1/4"	9' 4"	12' 1"
AT 312-3L60	1,745	37,230	68,430	7,990	(3) 25	390,100	17' 6-1/4"	9' 4"	12' 1"
AT 312-3M60	1,859	37,560	68,760	8,100	(3) 30	413,000	17' 6-1/4"	9' 4"	12' 1"
AT 312-3N60	2,083	38,340	69,540	8,360	(3) 40	451,400	17' 6-1/4"	9' 4"	12' 1"
AT 312-3O60	2,260	38,520	69,720	8,420	(3) 50	484,000	17' 6-1/4"	9' 4"	12' 1"
AT 312-4K60	1,707	39,780	70,980	8,840	(3) 20	357,600	18' 6-1/4"	10' 4"	13' 1"
AT 312-4L60	1,844	39,930	71,130	8,890	(3) 25	383,700	18' 6-1/4"	10' 4"	13' 1"
AT 312-4M60	1,955	40,260	71,460	9,000	(3) 30	406,400	18' 6-1/4"	10' 4"	13' 1"
AT 312-4N60	2,174	41,040	72,240	9,260	(3) 40	444,400	18' 6-1/4"	10' 4"	13' 1"
AT 312-4O60	2,352	41,220	72,420	9,320	(3) 50	476,100	18' 6-1/4"	10' 4"	13' 1"
AT 312-4P60	2,440	41,550	72,750	9,430	(3) 60	504,600	18' 6-1/4"	10' 4"	13' 1"
SLSF Addition		3,600	3,600	1,200			1' 3-1/2"	1' 3-1/2"	

- NOTE: (1) An adequately sized bleed line must be installed in the cooling tower system to prevent build-up of impurities in the recirculated water.
 (2) Do not use catalog drawings for certified prints. Dimensions and weights are subject to change.
 (3) Adequate spacing must be allowed for access to the cooling tower. Refer to EVAPCO's Equipment Layout Manual.
 (4) Nominal Tonnage is based on 3 gpm per ton at 95 degree entering water temperature, 85 degree leaving water temperature, and 78 degree wet-bulb temperature.
 (5) This box size is available in a dual fan/cell configuration.

◇ Outlet connection extends beyond bottom flange.
 † Height includes fan guard which ships factory mounted.

◆ Heaviest section is upper section.

Models: AT/UT/USS 424-2K40 to 424-4P40

Four-Cell Cooling Towers

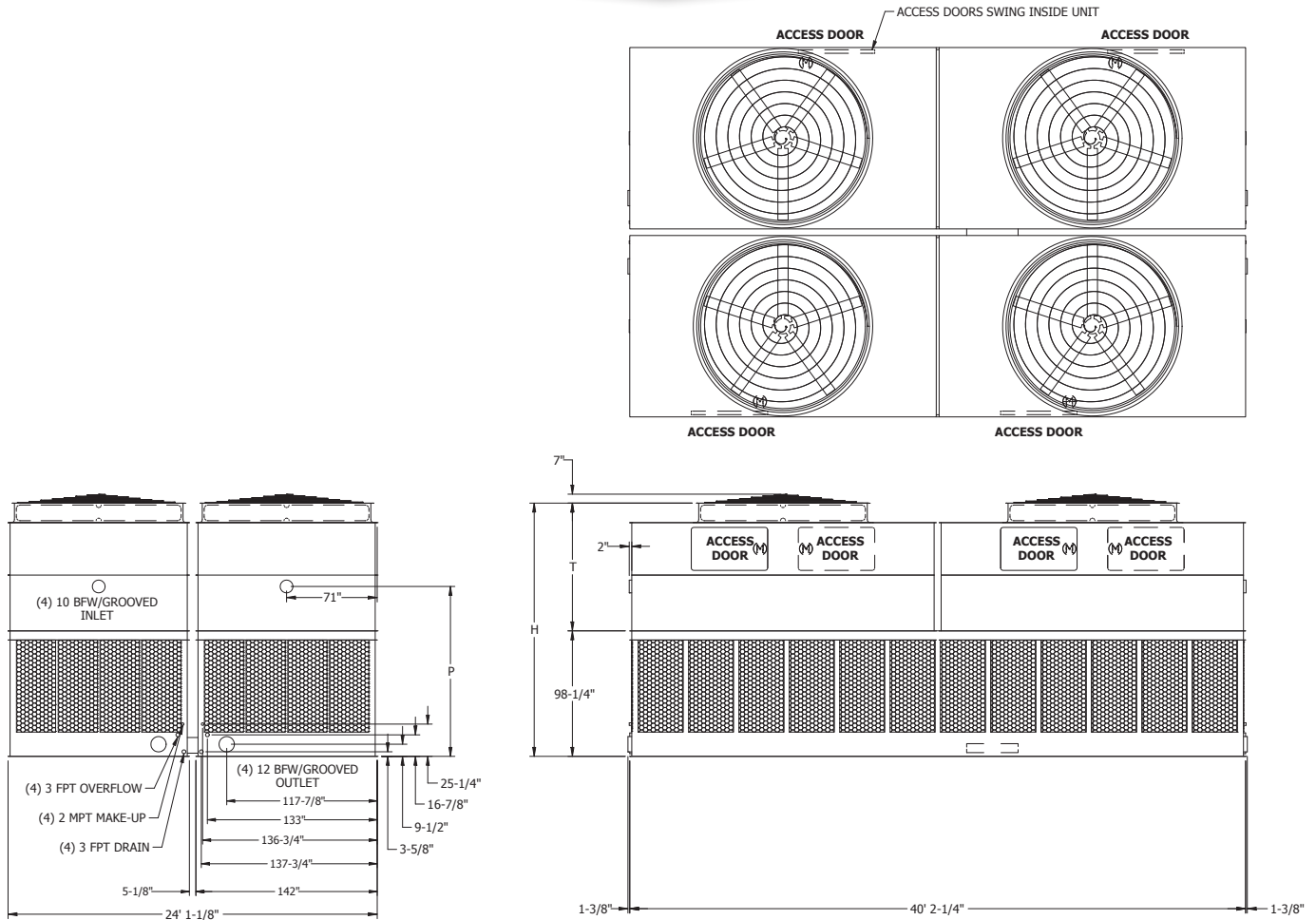

Model No.	Nominal Tonnage	WEIGHTS (LBS)			Fan Motor (HP)	Air Flow (CFM)	DIMENSIONS		
		Shipping	Operating	Heaviest Section†			H†	T†	P
AT 424-2K40	1,733	46,840	88,040	9,000	(4) 20	472,200	16' 6-1/4"	8' 4"	11' 1"
AT 424-2L40	1,919	47,040	88,240	9,000	(4) 25	506,800	16' 6-1/4"	8' 4"	11' 1"
AT 424-2M40	2,064	47,480	88,680	9,000	(4) 30	537,000	16' 6-1/4"	8' 4"	11' 1"
AT 424-2N40	2,379	48,520	89,720	9,000	(4) 40	587,500	16' 6-1/4"	8' 4"	11' 1"
AT 424-2O40	2,584	48,760	89,960	9,000	(4) 50	630,400	16' 6-1/4"	8' 4"	11' 1"
AT 424-3K40	2,038	49,760	90,960	9,000	(4) 20	464,500	17' 6-1/4"	9' 4"	12' 1"
AT 424-3L40	2,230	49,960	91,160	9,000	(4) 25	498,300	17' 6-1/4"	9' 4"	12' 1"
AT 424-3M40	2,380	50,400	91,600	9,000	(4) 30	527,600	17' 6-1/4"	9' 4"	12' 1"
AT 424-3N40	2,670	51,440	92,640	9,000	(4) 40	576,800	17' 6-1/4"	9' 4"	12' 1"
AT 424-3O40	2,900	51,680	92,880	9,000	(4) 50	618,200	17' 6-1/4"	9' 4"	12' 1"
AT 424-4K40	2,190	53,360	94,560	9,000	(4) 20	456,500	18' 6-1/4"	10' 4"	13' 1"
AT 424-4L40	2,369	53,560	94,760	9,000	(4) 25	489,900	18' 6-1/4"	10' 4"	13' 1"
AT 424-4M40	2,515	54,000	95,200	9,000	(4) 30	519,000	18' 6-1/4"	10' 4"	13' 1"
AT 424-4N40	2,798	55,040	96,240	9,260	(4) 40	567,600	18' 6-1/4"	10' 4"	13' 1"
AT 424-4O40	3,028	55,280	96,480	9,320	(4) 50	608,300	18' 6-1/4"	10' 4"	13' 1"
AT 424-4P40	3,141	55,720	96,920	9,430	(4) 60	644,800	18' 6-1/4"	10' 4"	13' 1"
SLSF Addition		4,800	4,800	1,200			1' 3-1/2"		

- NOTE: (1) An adequately sized bleed line must be installed in the cooling tower system to prevent build-up of impurities in the recirculated water.
 (2) Do not use catalog drawings for certified prints. Dimensions and weights are subject to change.
 (3) Adequate spacing must be allowed for access to the cooling tower. Refer to EVAPCO's Equipment Layout Manual.
 (4) Nominal Tonnage is based on 3 gpm per ton at 95 degree entering water temperature, 85 degree leaving water temperature, and 78 degree wet-bulb temperature.
 (5) This box size is available in a dual fan/cell configuration.

◇ Outlet connection extends beyond bottom flange.
 † Height includes fan guard which ships factory mounted.

◆ L=Lower Section, U=Upper Section

Models: AT/UT/USS 114-2K24 to 114-4R24

One-Cell Cooling Towers

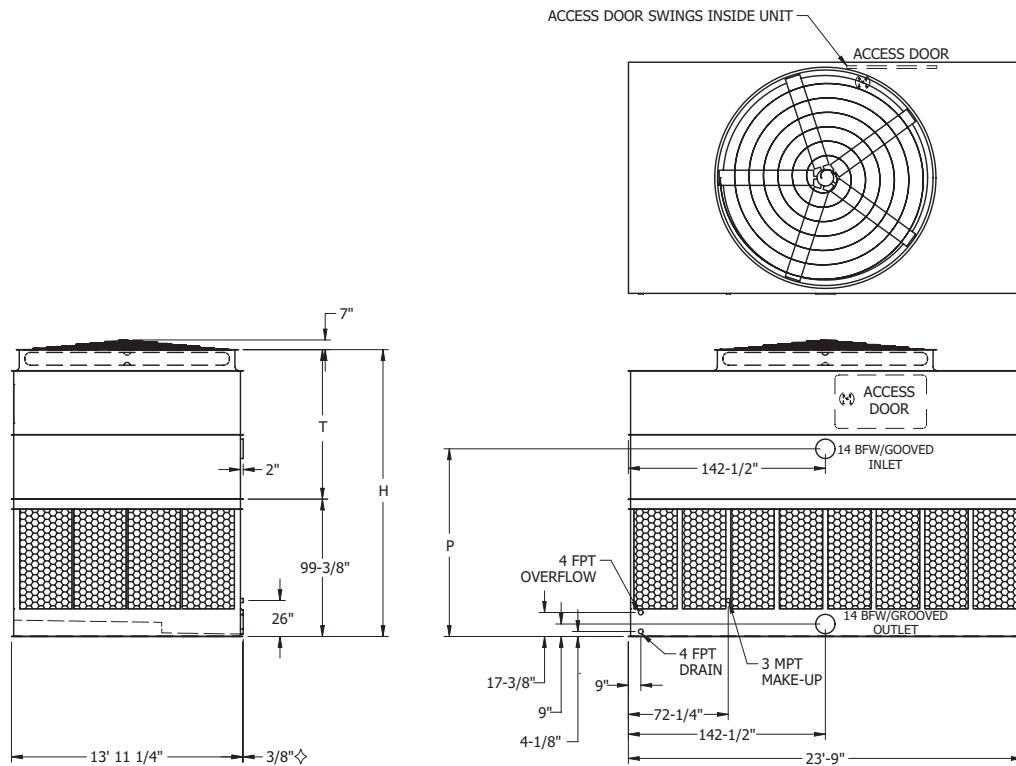

Model No.	Nominal Tonnage	WEIGHTS (LBS)			Fan Motor (HP)	Air Flow (CFM)	DIMENSIONS		
		Shipping	Operating	Heaviest Section [‡]			H [†]	T [†]	P
AT 114-2K24	619	16,870	32,720	10,600	20	159,500	17' 5-5/8"	9' 2-1/4"	11' 3-7/8"
AT 114-2L24	684	16,920	32,770	10,650	25	171,200	17' 5-5/8"	9' 2-1/4"	11' 3-7/8"
AT 114-2M24	722	16,940	32,790	10,670	30	181,500	17' 5-5/8"	9' 2-1/4"	11' 3-7/8"
AT 114-2N24	781	17,090	32,940	10,820	40	199,100	17' 5-5/8"	9' 2-1/4"	11' 3-7/8"
AT 114-2O24	839	17,440	33,290	11,170	50	213,800	17' 5-5/8"	9' 2-1/4"	11' 3-7/8"
AT 114-3K24	708	17,910	33,760	11,640	20	157,100	18' 5-5/8"	10' 2-1/4"	12' 3-7/8"
AT 114-3L24	775	17,960	33,810	11,690	25	168,500	18' 5-5/8"	10' 2-1/4"	12' 3-7/8"
AT 114-3M24	812	17,980	33,830	11,710	30	178,600	18' 5-5/8"	10' 2-1/4"	12' 3-7/8"
AT 114-3N24	892	18,130	33,980	11,860	40	195,500	18' 5-5/8"	10' 2-1/4"	12' 3-7/8"
AT 114-3O24	951	18,480	34,330	12,210	50	209,800	18' 5-5/8"	10' 2-1/4"	12' 3-7/8"
AT 114-3P24	1,008	18,650	34,500	12,380	60	222,100	18' 5-5/8"	10' 2-1/4"	12' 3-7/8"
AT 114-4K24	772	18,950	34,800	12,680	20	154,300	19' 5-5/8"	11' 2-1/4"	13' 3-7/8"
AT 114-4L24	834	19,000	34,850	12,730	25	165,600	19' 5-5/8"	11' 2-1/4"	13' 3-7/8"
AT 114-4M24	872	19,020	34,870	12,750	30	175,500	19' 5-5/8"	11' 2-1/4"	13' 3-7/8"
AT 114-4N24	947	19,170	35,020	12,900	40	192,300	19' 5-5/8"	11' 2-1/4"	13' 3-7/8"
AT 114-4O24	998	19,520	35,370	13,250	50	206,500	19' 5-5/8"	11' 2-1/4"	13' 3-7/8"
AT 114-4P24	1,056	19,690	35,540	13,420	60	218,600	19' 5-5/8"	11' 2-1/4"	13' 3-7/8"
AT 114-4Q24	1,135	19,930	35,780	13,660	75	234,300	19' 5-5/8"	11' 2-1/4"	13' 3-7/8"
AT 114-4R24	1,201	20,370	36,220	14,100	100	256,700	19' 5-5/8"	11' 2-1/4"	13' 3-7/8"
SLSF Addition		1,250	1,250	1,250			1' 1-1/2"	1' 1-1/2"	

- NOTE: (1) An adequately sized bleed line must be installed in the cooling tower system to prevent build-up of impurities in the recirculated water.
 (2) Do not use catalog drawings for certified prints. Dimensions and weights are subject to change.
 (3) Adequate spacing must be allowed for access to the cooling tower. Refer to EVAPCO's Equipment Layout Manual.
 (4) Nominal Tonnage is based on 3 gpm per ton at 95 degree entering water temperature, 85 degree leaving water temperature, and 78 degree wet-bulb temperature.

◇ Outlet connection extends beyond bottom flange.
 † Height includes fan guard which ships factory mounted.

◆ Heaviest section is upper section.

* Model available with gear drive only. Motor and access door located on 13' 11-1/4" unit end. Super Low Sound Fan is not available on this unit.

Models: AT/UT/USS 228-2K24 to 228-4R24

Two-Cell Cooling Towers

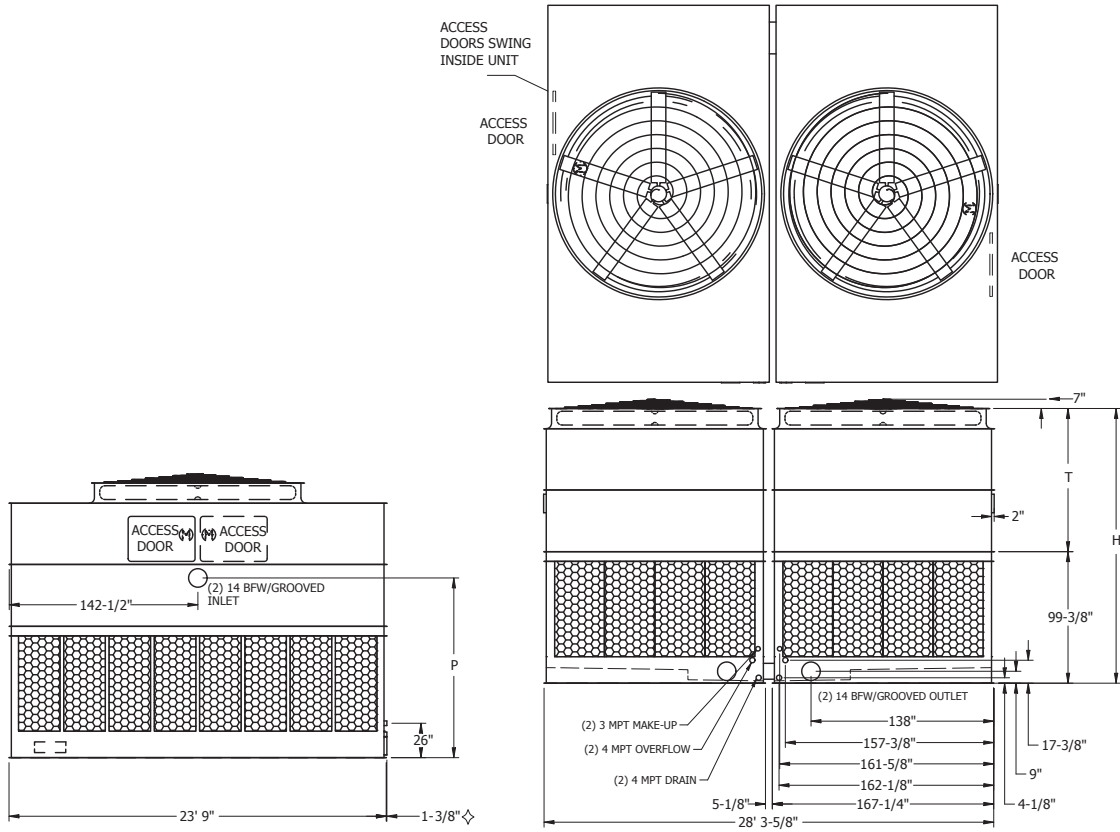

Model No.	Nominal Tonnage	WEIGHTS (LBS)			Fan Motor (HP)	Air Flow (CFM)	DIMENSIONS		
		Shipping	Operating	Heaviest Section†			H†	T†	P
AT 228-2K24	1,198	33,260	64,960	10,600	(2) 20	312,300	17' 5-5/8"	9' 2-1/4"	11' 3-7/8"
AT 228-2L24	1,329	33,360	65,060	10,650	(2) 25	335,200	17' 5-5/8"	9' 2-1/4"	11' 3-7/8"
AT 228-2M24	1,402	33,400	65,100	10,670	(2) 30	355,400	17' 5-5/8"	9' 2-1/4"	11' 3-7/8"
AT 228-2N24	1,520	33,700	65,400	10,820	(2) 40	389,900	17' 5-5/8"	9' 2-1/4"	11' 3-7/8"
AT 228-2O24	1,633	34,400	66,100	11,170	(2) 50	418,800	17' 5-5/8"	9' 2-1/4"	11' 3-7/8"
AT 228-3K24	1,376	35,340	67,040	11,640	(2) 20	307,600	18' 5-5/8"	10' 2-1/4"	12' 3-7/8"
AT 228-3L24	1,510	35,440	67,140	11,690	(2) 25	330,000	18' 5-5/8"	10' 2-1/4"	12' 3-7/8"
AT 228-3M24	1,582	35,480	67,180	11,710	(2) 30	349,800	18' 5-5/8"	10' 2-1/4"	12' 3-7/8"
AT 228-3N24	1,740	35,780	67,480	11,860	(2) 40	383,000	18' 5-5/8"	10' 2-1/4"	12' 3-7/8"
AT 228-3O24	1,855	36,480	68,180	12,210	(2) 50	411,000	18' 5-5/8"	10' 2-1/4"	12' 3-7/8"
AT 228-3P24	1,969	36,820	68,520	12,380	(2) 60	435,100	18' 5-5/8"	10' 2-1/4"	12' 3-7/8"
AT 228-4K24	1,508	37,420	69,120	12,680	(2) 20	302,100	19' 5-5/8"	11' 2-1/4"	13' 3-7/8"
AT 228-4L24	1,630	37,520	69,220	12,730	(2) 25	324,200	19' 5-5/8"	11' 2-1/4"	13' 3-7/8"
AT 228-4M24	1,706	37,560	69,260	12,750	(2) 30	343,700	19' 5-5/8"	11' 2-1/4"	13' 3-7/8"
AT 228-4N24	1,853	37,860	69,560	12,900	(2) 40	376,600	19' 5-5/8"	11' 2-1/4"	13' 3-7/8"
AT 228-4O24	1,952	38,560	70,260	13,250	(2) 50	404,400	19' 5-5/8"	11' 2-1/4"	13' 3-7/8"
AT 228-4P24	2,067	38,900	70,600	13,420	(2) 60	428,100	19' 5-5/8"	11' 2-1/4"	13' 3-7/8"
AT 228-4Q24	2,221	39,380	71,080	13,660	(2) 75	458,900	19' 5-5/8"	11' 2-1/4"	13' 3-7/8"
AT 228-4R24	2,350	40,260	71,960	14,100	(2) 100	502,900	19' 5-5/8"	11' 2-1/4"	13' 3-7/8"
SLSF Addition		2,500	2,500	1,250			1' 1-1/2"	1' 1-1/2"	

- NOTE: (1) An adequately sized bleed line must be installed in the cooling tower system to prevent build-up of impurities in the recirculated water.
 (2) Do not use catalog drawings for certified prints. Dimensions and weights are subject to change.
 (3) Adequate spacing must be allowed for access to the cooling tower. Refer to EVAPCO's Equipment Layout Manual.
 (4) Nominal Tonnage is based on 3 gpm per ton at 95 degree entering water temperature, 85 degree leaving water temperature, and 78 degree wet-bulb temperature.

◇ Outlet connection extends beyond bottom flange.
 † Height includes fan guard which ships factory mounted.

◆ Heaviest section is upper section.

Models: AT/UT/USS 214-2K48 to 214-4R48

Two-Cell Cooling Towers

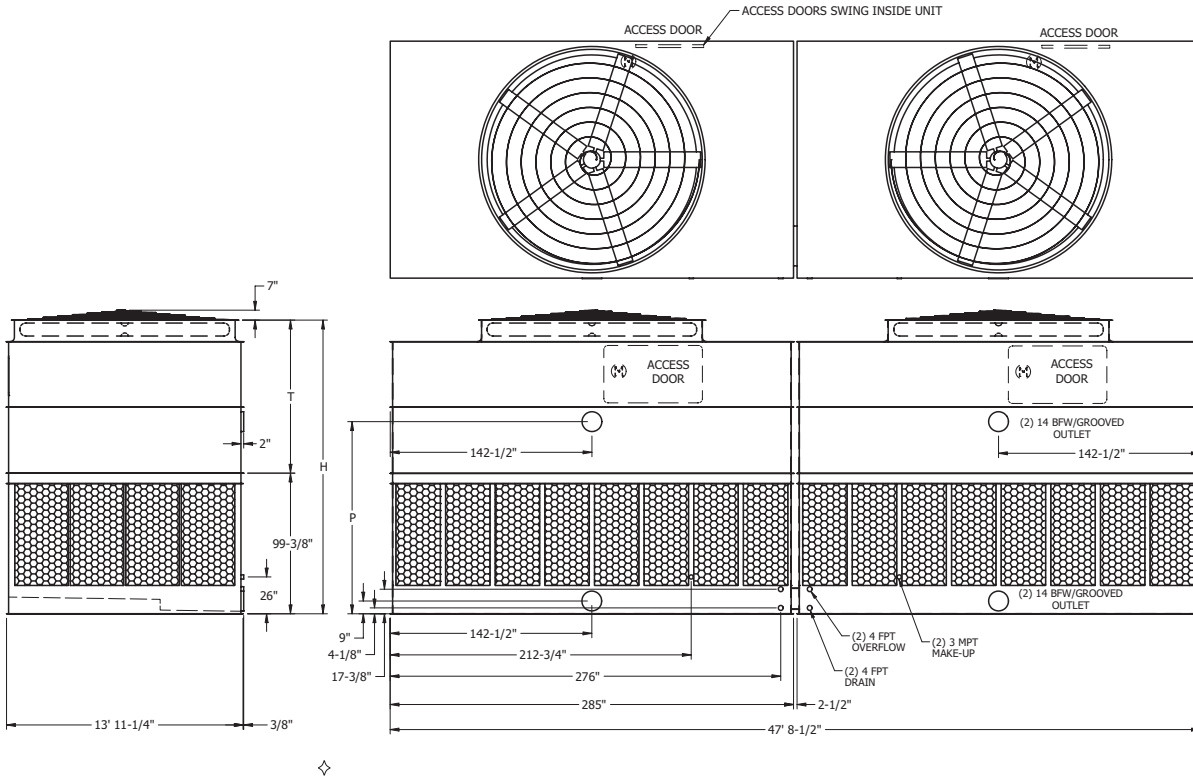

Model No.	Nominal Tonnage	WEIGHTS (LBS)			Fan Motor (HP)	Air Flow (CFM)	DIMENSIONS		
		Shipping	Operating	Heaviest Section [♦]			H [†]	T [†]	P
AT 214-2K48	1,205	33,420	65,120	10,600	(2) 20	313,500	17' 5-5/8"	9' 2-1/4"	11' 3-7/8"
AT 214-2L48	1,336	33,520	65,220	10,650	(2) 25	336,500	17' 5-5/8"	9' 2-1/4"	11' 3-7/8"
AT 214-2M48	1,410	33,560	65,260	10,670	(2) 30	356,800	17' 5-5/8"	9' 2-1/4"	11' 3-7/8"
AT 214-2N48	1,527	33,860	65,560	10,820	(2) 40	391,500	17' 5-5/8"	9' 2-1/4"	11' 3-7/8"
AT 214-2O48	1,641	34,560	66,260	11,170	(2) 50	420,400	17' 5-5/8"	9' 2-1/4"	11' 3-7/8"
AT 214-3K48	1,383	35,500	67,200	11,640	(2) 20	308,800	18' 5-5/8"	10' 2-1/4"	12' 3-7/8"
AT 214-3L48	1,517	35,600	67,300	11,690	(2) 25	331,200	18' 5-5/8"	10' 2-1/4"	12' 3-7/8"
AT 214-3M48	1,589	35,640	67,340	11,710	(2) 30	351,200	18' 5-5/8"	10' 2-1/4"	12' 3-7/8"
AT 214-3N48	1,748	35,940	67,640	11,860	(2) 40	384,400	18' 5-5/8"	10' 2-1/4"	12' 3-7/8"
AT 214-3O48	1,863	36,640	68,340	12,210	(2) 50	412,500	18' 5-5/8"	10' 2-1/4"	12' 3-7/8"
AT 214-3P48	1,978	36,980	68,680	12,380	(2) 60	436,800	18' 5-5/8"	10' 2-1/4"	12' 3-7/8"
AT 214-4K48	1,514	37,580	69,280	12,680	(2) 20	303,200	19' 5-5/8"	11' 2-1/4"	13' 3-7/8"
AT 214-4L48	1,637	37,680	69,380	12,730	(2) 25	325,400	19' 5-5/8"	11' 2-1/4"	13' 3-7/8"
AT 214-4M48	1,713	37,720	69,420	12,750	(2) 30	345,000	19' 5-5/8"	11' 2-1/4"	13' 3-7/8"
AT 214-4N48	1,860	38,020	69,720	12,900	(2) 40	378,000	19' 5-5/8"	11' 2-1/4"	13' 3-7/8"
AT 214-4O48	1,960	38,720	70,420	13,250	(2) 50	405,900	19' 5-5/8"	11' 2-1/4"	13' 3-7/8"
AT 214-4P48	2,075	39,060	70,760	13,420	(2) 60	429,800	19' 5-5/8"	11' 2-1/4"	13' 3-7/8"
AT 214-4Q48	2,230	39,540	71,240	13,660	(2) 75	460,600	19' 5-5/8"	11' 2-1/4"	13' 3-7/8"
AT 214-4R48	2,359	40,420	72,120	14,100	(2) 100	504,800	19' 5-5/8"	11' 2-1/4"	13' 3-7/8"
SLSF Addition		2,500	2,500	1,250			1' 1-1/2"	1' 1-1/2"	

- NOTE: (1) An adequately sized bleed line must be installed in the cooling tower system to prevent build-up of impurities in the recirculated water.
 (2) Do not use catalog drawings for certified prints. Dimensions and weights are subject to change.
 (3) Adequate spacing must be allowed for access to the cooling tower. Refer to EVAPCO's Equipment Layout Manual.
 (4) Nominal Tonnage is based on 3 gpm per ton at 95 degree entering water temperature, 85 degree leaving water temperature, and 78 degree wet-bulb temperature.

♦ Outlet connection extends beyond bottom flange.

♦ Heaviest section is upper section.

† Height includes fan guard which ships factory mounted.

* Model available with gear drive only. Motors and access doors located on 13'11-1/4" unit ends. Super Low Sound Fan is not available on this unit.

Models: AT/UT/USS 314-2K72 to 314-4Q72

Three-Cell Cooling Towers

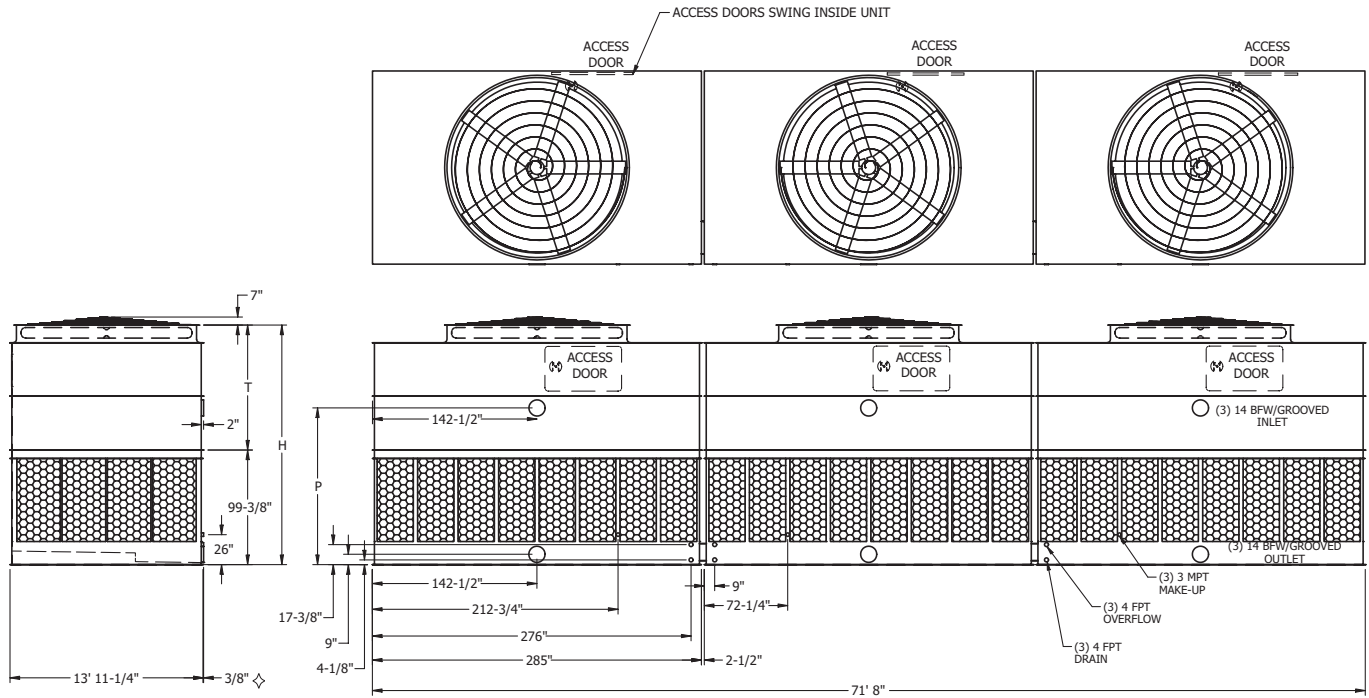

Model No.	Nominal Tonnage	WEIGHTS (LBS)			Fan Motor (HP)	Air Flow (CFM)	DIMENSIONS		
		Shipping	Operating	Heaviest Section†			H†	T†	P
AT 314-2K72	1,789	49,980	97,530	10,600	(3) 20	467,000	17' 5-5/8"	9' 2-1/4"	11' 3-7/8"
AT 314-2L72	1,986	50,130	97,680	10,650	(3) 25	501,300	17' 5-5/8"	9' 2-1/4"	11' 3-7/8"
AT 314-2M72	2,095	50,190	97,740	10,670	(3) 30	531,600	17' 5-5/8"	9' 2-1/4"	11' 3-7/8"
AT 314-2N72	2,271	50,640	98,190	10,820	(3) 40	583,200	17' 5-5/8"	9' 2-1/4"	11' 3-7/8"
AT 314-2O72	2,439	51,690	99,240	11,170	(3) 50	626,300	17' 5-5/8"	9' 2-1/4"	11' 3-7/8"
AT 314-3K72	2,056	53,100	100,650	11,640	(3) 20	460,000	18' 5-5/8"	10' 2-1/4"	12' 3-7/8"
AT 314-3L72	2,257	53,250	100,800	11,690	(3) 25	493,500	18' 5-5/8"	10' 2-1/4"	12' 3-7/8"
AT 314-3M72	2,364	53,310	100,860	11,710	(3) 30	523,200	18' 5-5/8"	10' 2-1/4"	12' 3-7/8"
AT 314-3N72	2,601	53,760	101,310	11,860	(3) 40	572,800	18' 5-5/8"	10' 2-1/4"	12' 3-7/8"
AT 314-3O72	2,773	54,810	102,360	12,210	(3) 50	614,600	18' 5-5/8"	10' 2-1/4"	12' 3-7/8"
AT 314-3P72	2,944	55,320	102,870	12,380	(3) 60	650,800	18' 5-5/8"	10' 2-1/4"	12' 3-7/8"
AT 314-4K72	2,255	56,220	103,770	12,680	(3) 20	451,700	19' 5-5/8"	11' 2-1/4"	13' 3-7/8"
AT 314-4L72	2,437	56,370	103,920	12,730	(3) 25	484,800	19' 5-5/8"	11' 2-1/4"	13' 3-7/8"
AT 314-4M72	2,551	56,430	103,980	12,750	(3) 30	514,000	19' 5-5/8"	11' 2-1/4"	13' 3-7/8"
AT 314-4N72	2,770	56,880	104,430	12,900	(3) 40	563,200	19' 5-5/8"	11' 2-1/4"	13' 3-7/8"
AT 314-4O72	2,919	57,930	105,480	13,250	(3) 50	604,800	19' 5-5/8"	11' 2-1/4"	13' 3-7/8"
AT 314-4P72	3,091	58,440	105,990	13,420	(3) 60	640,300	19' 5-5/8"	11' 2-1/4"	13' 3-7/8"
AT 314-4Q72	3,322	59,160	106,710	13,660	(3) 75	686,300	19' 5-5/8"	11' 2-1/4"	13' 3-7/8"
SLSF Addition		3,750	3,750	1,250			1' 1-1/2"	1' 1-1/2"	

- NOTE: (1) An adequately sized bleed line must be installed in the cooling tower system to prevent build-up of impurities in the recirculated water.
 (2) Do not use catalog drawings for certified prints. Dimensions and weights are subject to change.
 (3) Adequate spacing must be allowed for access to the cooling tower. Refer to EVAPCO's Equipment Layout Manual.
 (4) Nominal Tonnage is based on 3 gpm per ton at 95 degree entering water temperature, 85 degree leaving water temperature, and 78 degree wet-bulb temperature.

◇ Outlet connection extends beyond bottom flange.
 † Height includes fan guard which ships factory mounted.

◆ Heaviest section is upper section.

Models: AT/UT/USS 428-2K48 to 428-4R48

Four-Cell Cooling Towers

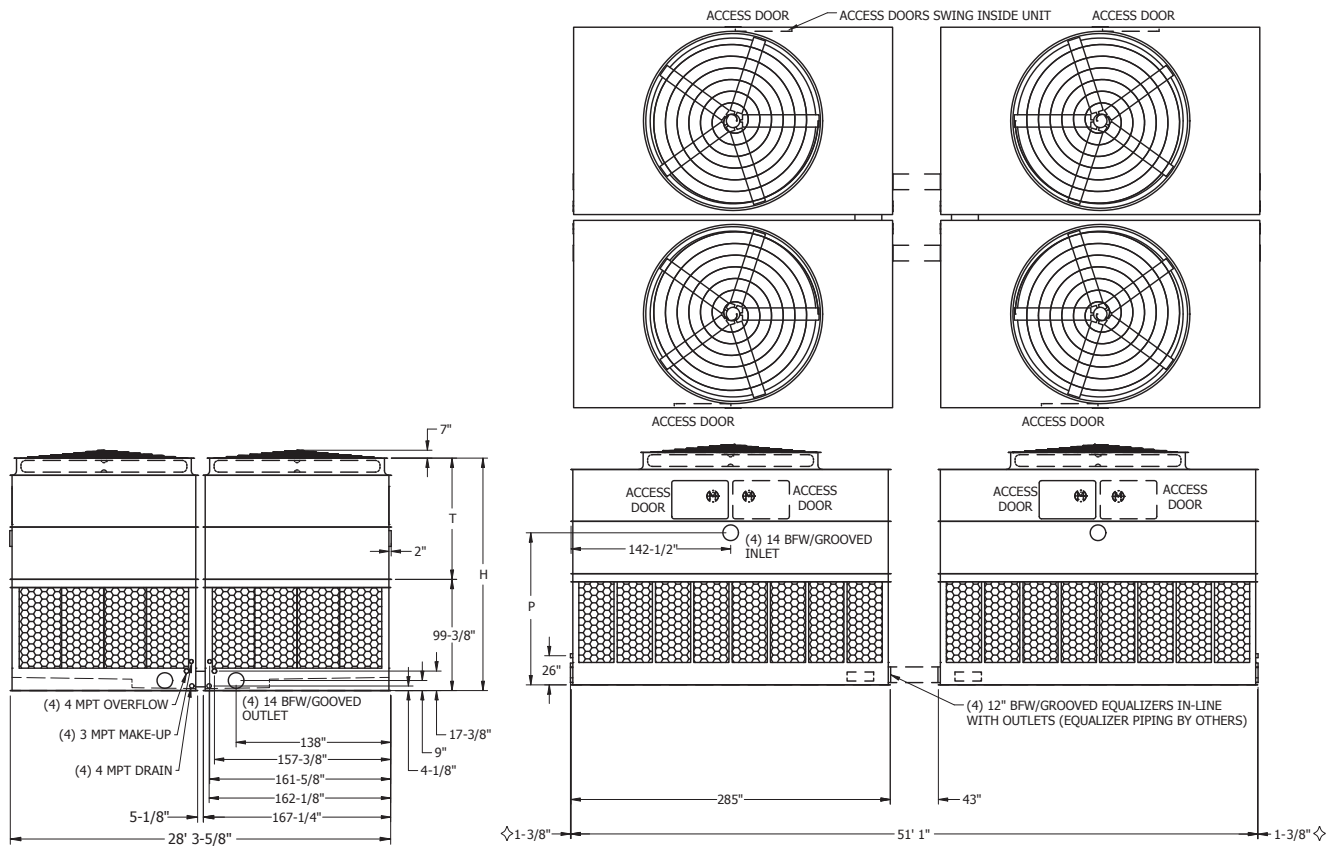

Model No.	Nominal Tonnage	WEIGHTS (LBS)			Fan Motor (HP)	Air Flow (CFM)	DIMENSIONS		
		Shipping	Operating	Heaviest Section†			H†	T†	P
AT 428-2K48	2,231	66,560	129,960	10,600	(4)20	595,300	17' 5-5/8"	9' 2-1/4"	11' 3-7/8"
AT 428-2L48	2,482	66,760	130,160	10,650	(4)25	639,000	17' 5-5/8"	9' 2-1/4"	11' 3-7/8"
AT 428-2M48	2,626	66,840	130,240	10,670	(4)30	677,600	17' 5-5/8"	9' 2-1/4"	11' 3-7/8"
AT 428-2N48	2,846	67,440	130,840	10,820	(4)40	743,500	17' 5-5/8"	9' 2-1/4"	11' 3-7/8"
AT 428-2O48	3,067	68,840	132,240	11,170	(4)50	798,500	17' 5-5/8"	9' 2-1/4"	11' 3-7/8"
AT 428-3K48	2,585	70,720	134,120	11,640	(4)20	586,200	18' 5-5/8"	10' 2-1/4"	12' 3-7/8"
AT 428-3L48	2,837	70,920	134,320	11,690	(4)25	629,300	18' 5-5/8"	10' 2-1/4"	12' 3-7/8"
AT 428-3M48	2,984	71,000	134,400	11,710	(4)30	667,200	18' 5-5/8"	10' 2-1/4"	12' 3-7/8"
AT 428-3N48	3,283	71,600	135,000	11,860	(4)40	730,800	18' 5-5/8"	10' 2-1/4"	12' 3-7/8"
AT 428-3O48	3,509	73,000	136,400	12,210	(4)50	784,200	18' 5-5/8"	10' 2-1/4"	12' 3-7/8"
AT 428-3P48	3,728	73,680	137,080	12,380	(4)60	830,200	18' 5-5/8"	10' 2-1/4"	12' 3-7/8"
AT 428-4K48	2,858	74,880	138,280	12,680	(4)20	575,800	19' 5-5/8"	11' 2-1/4"	13' 3-7/8"
AT 428-4L48	3,093	75,080	138,480	12,730	(4)25	618,100	19' 5-5/8"	11' 2-1/4"	13' 3-7/8"
AT 428-4M48	3,237	75,160	138,560	12,750	(4)30	655,300	19' 5-5/8"	11' 2-1/4"	13' 3-7/8"
AT 428-4N48	3,524	75,760	139,160	12,900	(4)40	718,100	19' 5-5/8"	11' 2-1/4"	13' 3-7/8"
AT 428-4O48	3,714	77,160	140,560	13,250	(4)50	771,300	19' 5-5/8"	11' 2-1/4"	13' 3-7/8"
AT 428-4P48	3,933	77,840	141,240	13,420	(4)60	816,800	19' 5-5/8"	11' 2-1/4"	13' 3-7/8"
AT 428-4Q48	4,229	78,800	142,200	13,660	(4)75	875,700	19' 5-5/8"	11' 2-1/4"	13' 3-7/8"
AT 428-4R48	4,475	80,560	143,960	14,100	(4)100	960,000	19' 5-5/8"	11' 2-1/4"	13' 3-7/8"
SLSF Addition		5,000	5,000	1,250			1' 1-1/2"	1' 1-1/2"	

- NOTE: (1) An adequately sized bleed line must be installed in the cooling tower system to prevent build-up of impurities in the recirculated water.
 (2) Do not use catalog drawings for certified prints. Dimensions and weights are subject to change.
 (3) Adequate spacing must be allowed for access to the cooling tower. Refer to EVAPCO's Equipment Layout Manual.
 (4) Nominal Tonnage is based on 3 gpm per ton at 95 degree entering water temperature, 85 degree leaving water temperature, and 78 degree wet-bulb temperature.

◇ Outlet connection extends beyond bottom flange.
 † Height includes fan guard which ships factory mounted.

◆ Heaviest section is upper section.

Models: AT/UT/USS 114-5K26 to 114-5O26

One-Cell Cooling Towers

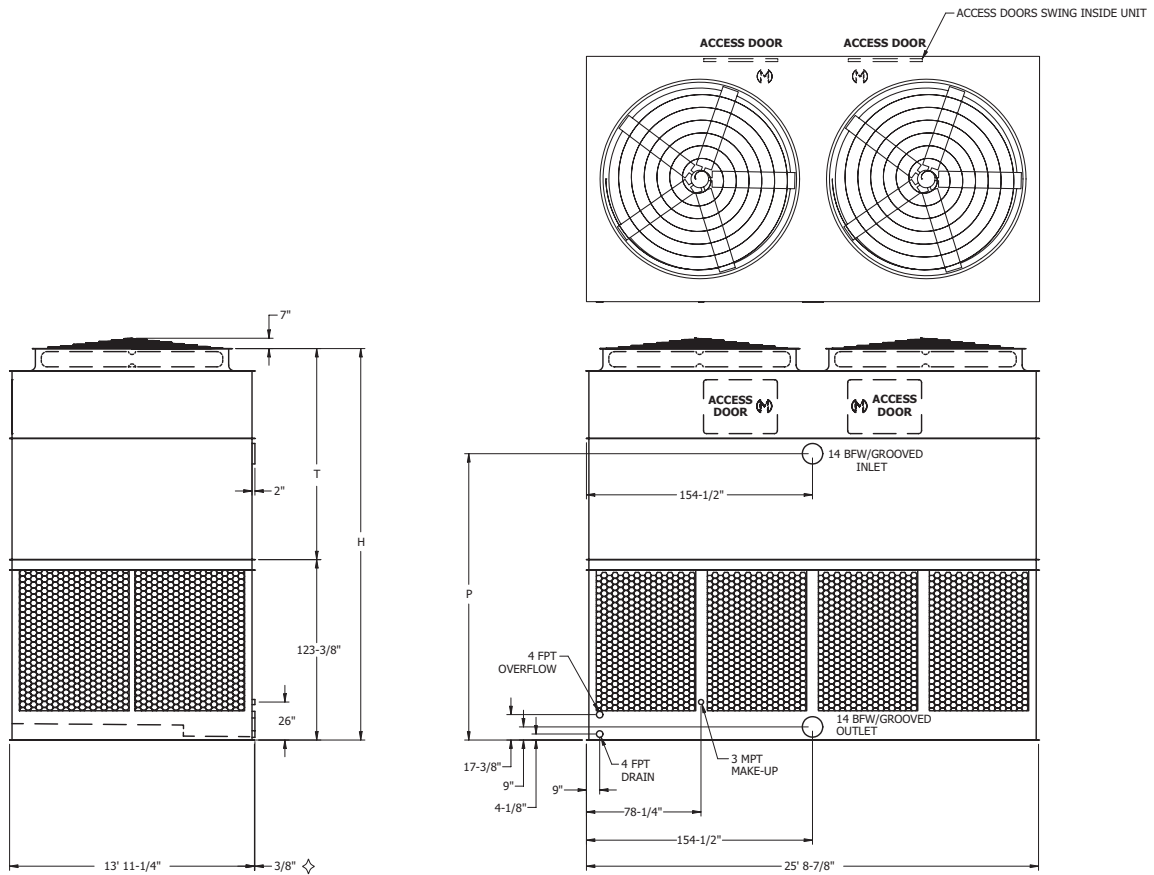

Model No.	Nominal Tonnage	WEIGHTS (LBS)			Fan Motor (HP)	Air Flow (CFM)	DIMENSIONS		
		Shipping	Operating	Heaviest Section†			H†	T†	P
AT 114-5K26	1,003	24,640	41,470	17,660	(2) 20	200,200	22' 3-1/2"	12' 1/8"	16' 3-3/4"
AT 114-5L26	1,078	24,700	41,530	17,720	(2) 25	214,700	22' 3-1/2"	12' 1/8"	16' 3-3/4"
AT 114-5M26	1,142	24,800	41,630	17,820	(2) 30	227,300	22' 3-1/2"	12' 1/8"	16' 3-3/4"
AT 114-5N26	1,247	25,120	41,950	18,140	(2) 40	248,500	22' 3-1/2"	12' 1/8"	16' 3-3/4"
AT 114-5O26	1,332	25,140	41,970	18,160	(2) 50	266,300	22' 3-1/2"	12' 1/8"	16' 3-3/4"
SLSF Addition		2,400	2,400	1,200			1' 3-1/2"	1' 3-1/2"	

- NOTE: (1) An adequately sized bleed line must be installed in the cooling tower system to prevent build-up of impurities in the recirculated water.
 (2) Do not use catalog drawings for certified prints. Dimensions and weights are subject to change.
 (3) Adequate spacing must be allowed for access to the cooling tower. Refer to EVAPCO's Equipment Layout Manual.
 (4) Nominal Tonnage is based on 3 gpm per ton at 95 degree entering water temperature, 85 degree leaving water temperature, and 78 degree wet-bulb temperature.
 (5) This box size is available in a dual fan/cell configuration.

◇ Outlet connection extends beyond bottom flange.
 † Height includes fan guard which ships factory mounted.

◆ Heaviest section is upper section.

Models: AT/UT/USS 228-5K26 to 228-5O26

Two-Cell Cooling Towers

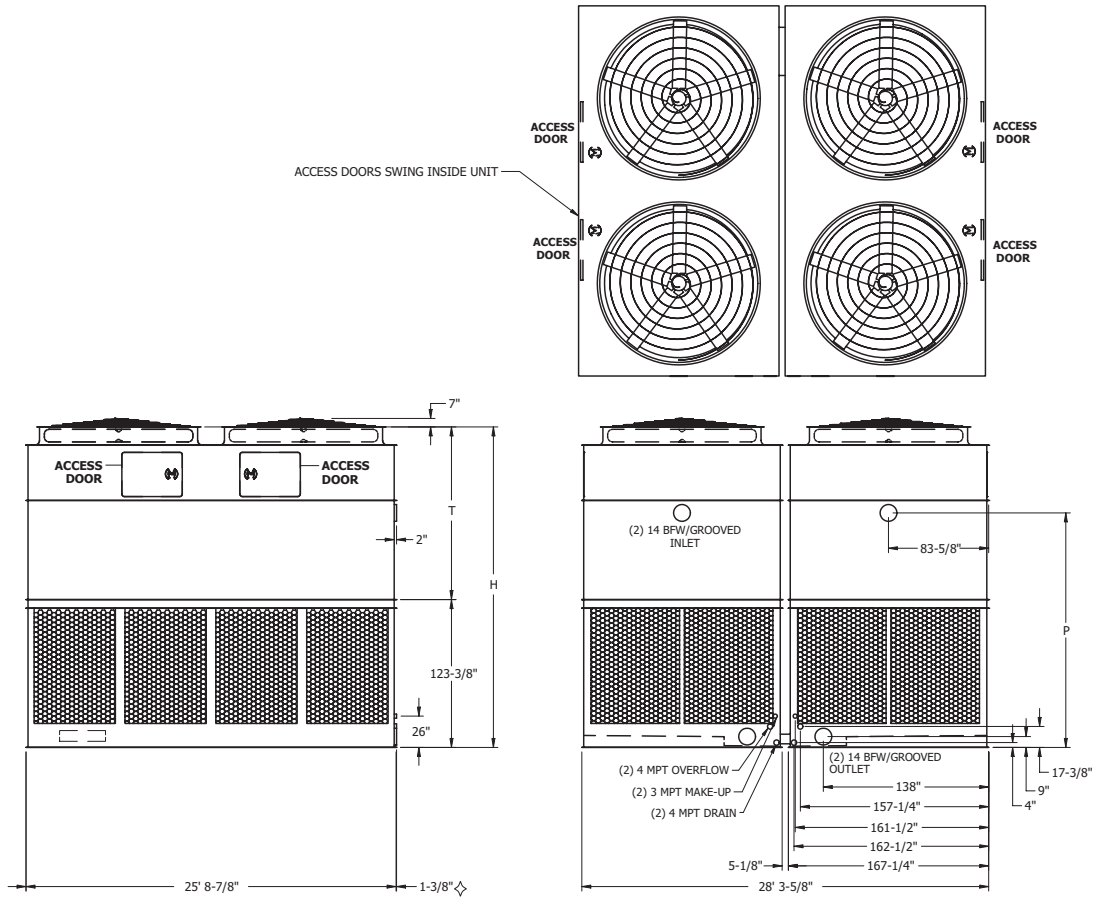

Model No.	Nominal Tonnage	WEIGHTS (LBS)			Fan Motor (HP)	Air Flow (CFM)	DIMENSIONS		
		Shipping	Operating	Heaviest Section†			H†	T†	P
AT 228-5K26	1,963	48,560	82,220	17,660	(4) 20	392,000	22' 3-1/2"	12' 1/8"	16' 3-3/4"
AT 228-5L26	2,111	48,680	82,340	17,720	(4) 25	420,400	22' 3-1/2"	12' 1/8"	16' 3-3/4"
AT 228-5M26	2,236	48,880	82,540	17,820	(4) 30	445,100	22' 3-1/2"	12' 1/8"	16' 3-3/4"
AT 228-5N26	2,443	49,520	83,180	18,140	(4) 40	486,800	22' 3-1/2"	12' 1/8"	16' 3-3/4"
AT 228-5O26	2,613	49,560	83,220	18,160	(4) 50	521,700	22' 3-1/2"	12' 1/8"	16' 3-3/4"
SLSF Addition		4,800	4,800	1,200			1' 3-1/2"	1' 3-1/2"	

- NOTE: (1) An adequately sized bleed line must be installed in the cooling tower system to prevent build-up of impurities in the recirculated water.
 (2) Do not use catalog drawings for certified prints. Dimensions and weights are subject to change.
 (3) Adequate spacing must be allowed for access to the cooling tower. Refer to EVAPCO's Equipment Layout Manual.
 (4) Nominal Tonnage is based on 3 gpm per ton at 95 degree entering water temperature, 85 degree leaving water temperature, and 78 degree wet-bulb temperature.
 (5) This box size is available in a dual fan/cell configuration.

♦ Outlet connection extends beyond bottom flange.
 † Height includes fan guard which ships factory mounted.

♦ Heaviest section is upper section.

Models: AT/UT/USS 214-5K52 to 214-5O52

Two-Cell Cooling Towers

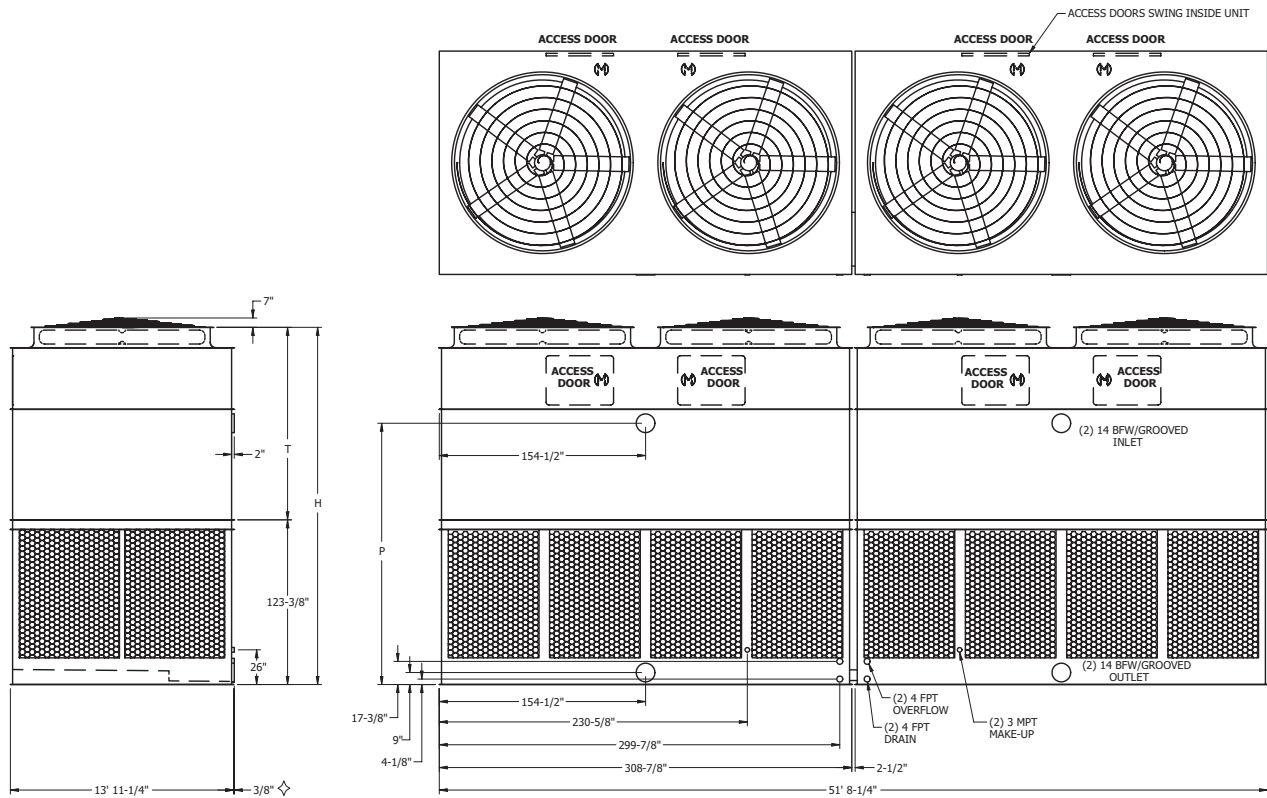

Model No.	Nominal Tonnage	WEIGHTS (LBS)			Fan Motor (HP)	Air Flow (CFM)	DIMENSIONS		
		Shipping	Operating	Heaviest Section [‡]			H [†]	T [†]	P
AT 214-5K52	1,971	48,840	82,500	17,660	(4) 20	393,500	22' 3-1/2"	12' 1/8"	16' 3-3/4"
AT 214-5L52	2,119	48,960	82,620	17,720	(4) 25	422,100	22' 3-1/2"	12' 1/8"	16' 3-3/4"
AT 214-5M52	2,245	49,160	82,820	17,820	(4) 30	446,800	22' 3-1/2"	12' 1/8"	16' 3-3/4"
AT 214-5N52	2,452	49,800	83,460	18,140	(4) 40	488,700	22' 3-1/2"	12' 1/8"	16' 3-3/4"
AT 214-5O52	2,622	49,840	83,500	18,160	(4) 50	523,700	22' 3-1/2"	12' 1/8"	16' 3-3/4"
SLSF Addition		4,800	4,800	1,200			1' 3-1/2"	1' 3-1/2"	

- NOTE: (1) An adequately sized bleed line must be installed in the cooling tower system to prevent build-up of impurities in the recirculated water.
 (2) Do not use catalog drawings for certified prints. Dimensions and weights are subject to change.
 (3) Adequate spacing must be allowed for access to the cooling tower. Refer to EVAPCO's Equipment Layout Manual.
 (4) Nominal Tonnage is based on 3 gpm per ton at 95 degree entering water temperature, 85 degree leaving water temperature, and 78 degree wet-bulb temperature.
 (5) This box size is available in a dual fan/cell configuration.

◇ Outlet connection extends beyond bottom flange.
 † Height includes fan guard which ships factory mounted.

‡ Heaviest section is upper section.

Models: AT/UT/USS 314-5K78 to 314-5O78

Three-Cell Cooling Towers

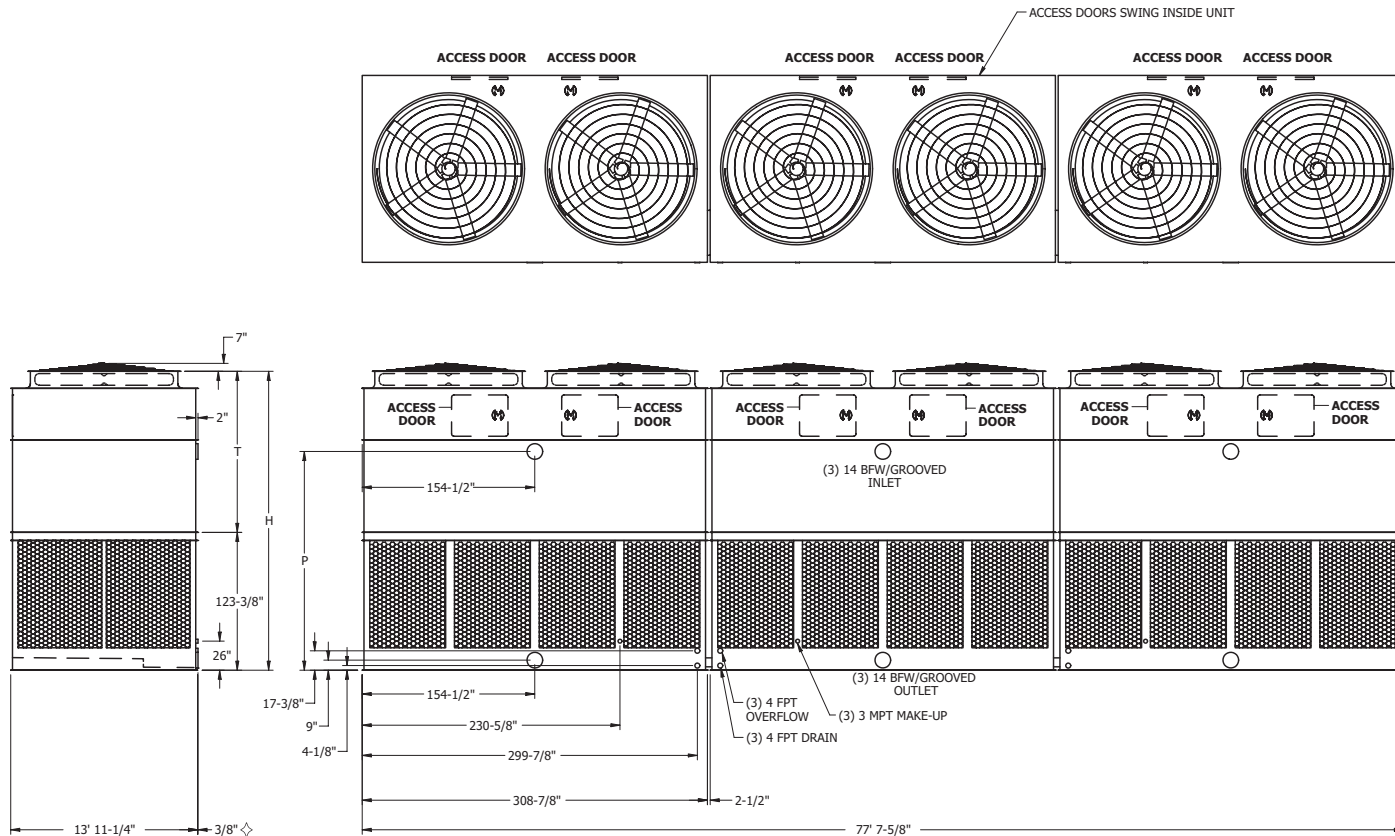

Model No.	Nominal Tonnage	WEIGHTS (LBS)			Fan Motor (HP)	Air Flow (CFM)	DIMENSIONS		
		Shipping	Operating	Heaviest Section [‡]			H [†]	T [†]	P
AT 314-5K78	2,936	73,050	123,540	17,660	(6) 20	586,300	22' 3-1/2"	12' 1/8"	16' 3-3/4"
AT 314-5L78	3,157	73,230	123,720	17,720	(6) 25	628,800	22' 3-1/2"	12' 1/8"	16' 3-3/4"
AT 314-5M78	3,344	73,530	124,020	17,820	(6) 30	665,700	22' 3-1/2"	12' 1/8"	16' 3-3/4"
AT 314-5N78	3,655	74,490	124,980	18,140	(6) 40	728,100	22' 3-1/2"	12' 1/8"	16' 3-3/4"
AT 314-5O78	3,908	74,550	125,040	18,160	(6) 50	780,300	22' 3-1/2"	12' 1/8"	16' 3-3/4"
SLSF Addition		3,600	3,600	1,200			1' 3-1/2"	1' 3-1/2"	

- NOTE: (1) An adequately sized bleed line must be installed in the cooling tower system to prevent build-up of impurities in the recirculated water.
 (2) Do not use catalog drawings for certified prints. Dimensions and weights are subject to change.
 (3) Adequate spacing must be allowed for access to the cooling tower. Refer to EVAPCO's Equipment Layout Manual.
 (4) Nominal Tonnage is based on 3 gpm per ton at 95 degree entering water temperature, 85 degree leaving water temperature, and 78 degree wet-bulb temperature.
 (5) This box size is available in a dual fan/cell configuration.

◇ Outlet connection extends beyond bottom flange.
 † Height includes fan guard which ships factory mounted.

‡ Heaviest section is upper section.

Models: AT/UT/USS 428-5K52 to 428-5O52

Four-Cell Cooling Towers

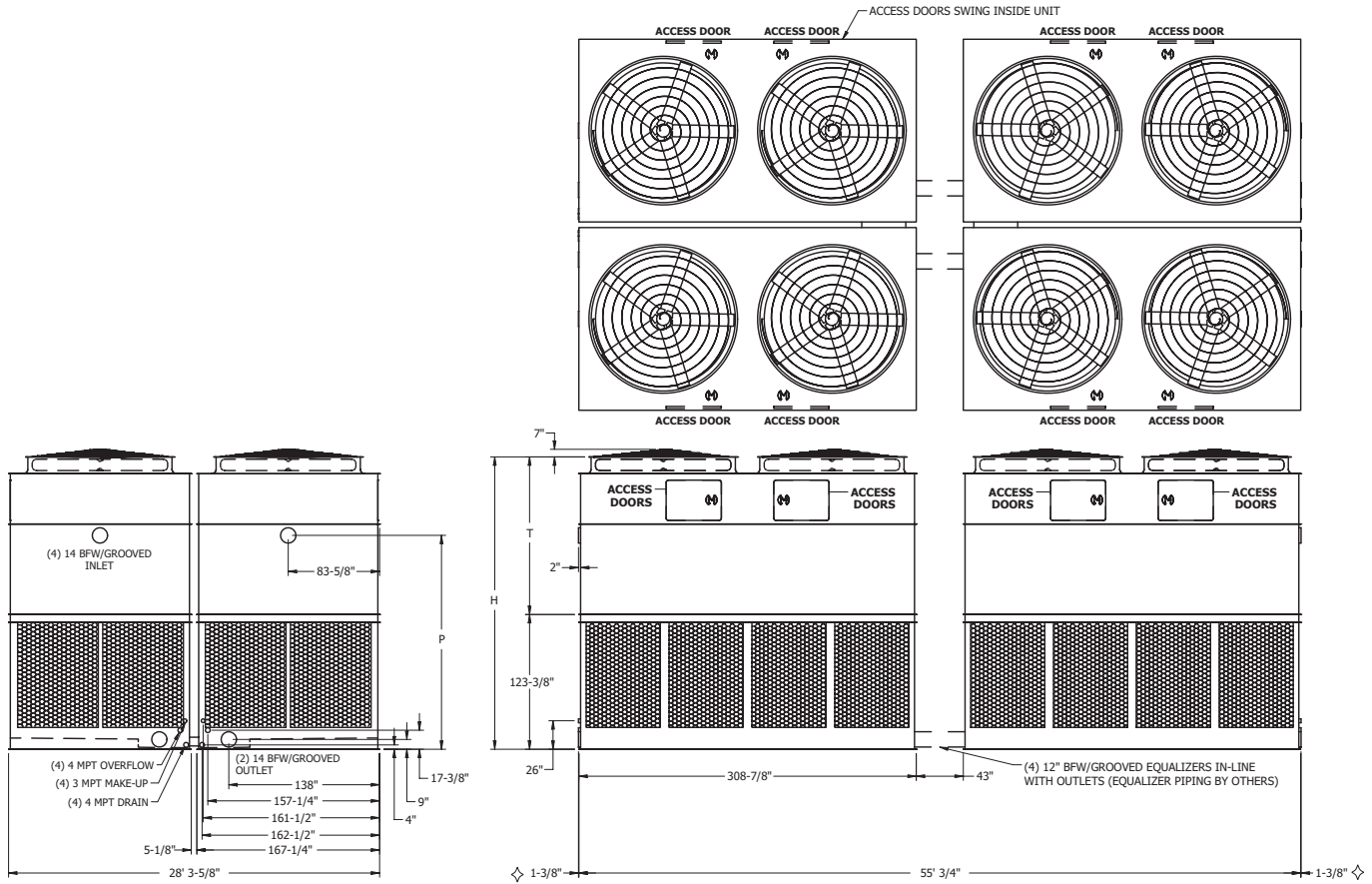

Model No.	Nominal Tonnage	WEIGHTS (LBS)			Fan Motor (HP)	Air Flow (CFM)	DIMENSIONS		
		Shipping	Operating	Heaviest Section†			H†	T†	P
AT 428-5K52	3,857	97,200	164,520	17,660	(8) 20	746,200	22' 3-1/2"	12' 1/8"	16' 3-3/4"
AT 428-5L52	4,148	97,440	164,760	17,720	(8) 25	800,400	22' 3-1/2"	12' 1/8"	16' 3-3/4"
AT 428-5M52	4,395	97,840	165,160	17,820	(8) 30	847,500	22' 3-1/2"	12' 1/8"	16' 3-3/4"
AT 428-5N52	4,806	99,120	166,440	18,140	(8) 40	927,000	22' 3-1/2"	12' 1/8"	16' 3-3/4"
AT 428-5O52	5,141	99,200	166,520	18,160	(8) 50	993,400	22' 3-1/2"	12' 1/8"	16' 3-3/4"
SLSF Addition		9,600	9,600	1,200			1' 3-1/2"	1' 3-1/2"	

- NOTE: (1) An adequately sized bleed line must be installed in the cooling tower system to prevent build-up of impurities in the recirculated water.
 (2) Do not use catalog drawings for certified prints. Dimensions and weights are subject to change.
 (3) Adequate spacing must be allowed for access to the cooling tower. Refer to EVAPCO's Equipment Layout Manual.
 (4) Nominal Tonnage is based on 3 gpm per ton at 95 degree entering water temperature, 85 degree leaving water temperature, and 78 degree wet-bulb temperature.
 (5) This box size is available in a dual fan/cell configuration.

◇ Outlet connection extends beyond bottom flange.
 † Height includes fan guard which ships factory mounted.

◆ Heaviest section is upper section.

Models: AT/UT/USS 456-5K26 to 456-5O26

Four-Cell Cooling Towers

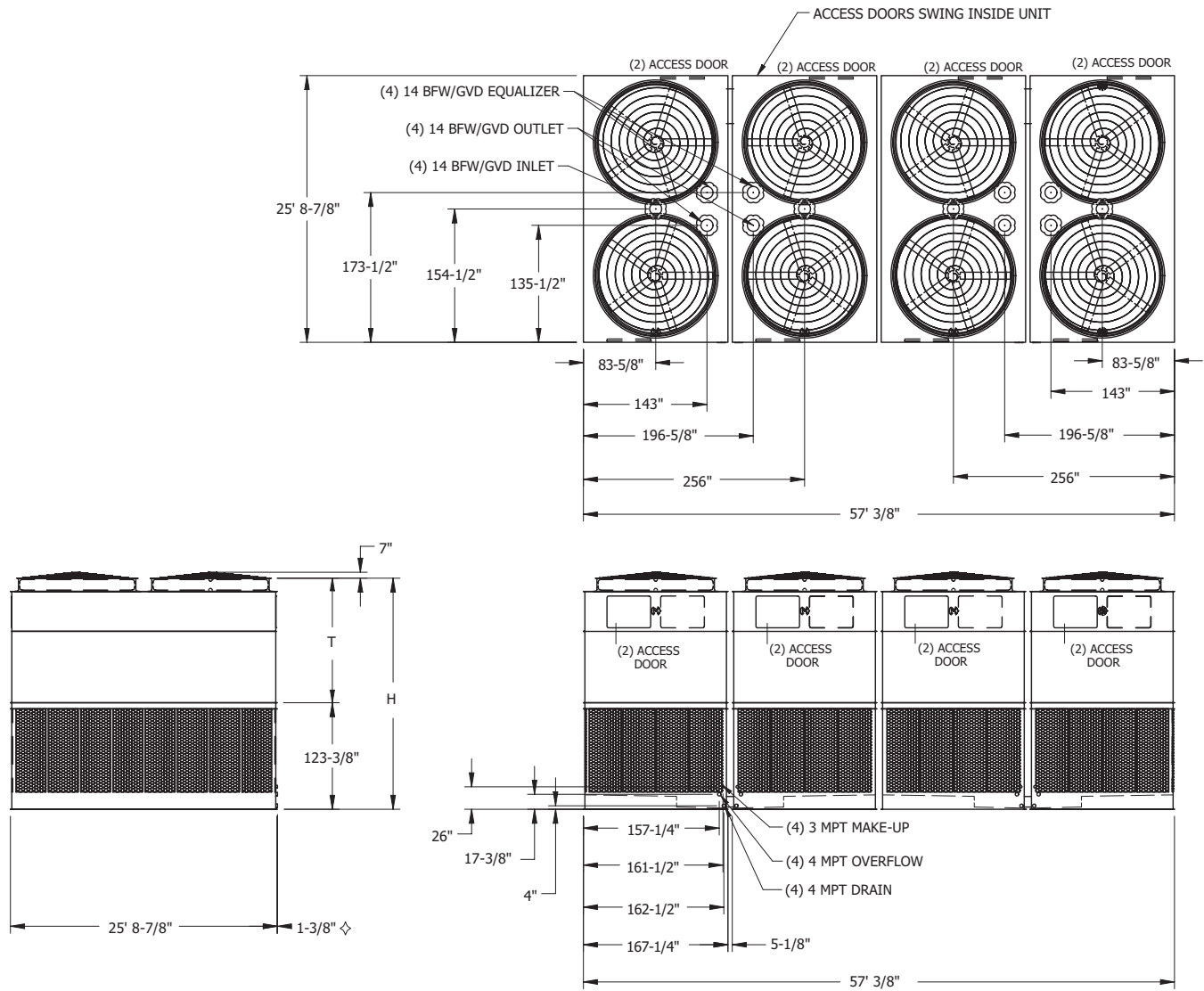

Model No.	Nominal Tonnage	WEIGHTS (LBS)			FanMotor (HP)	Air Flow (CFM)	DIMENSIONS	
		Shipping	Operating	Heaviest Section [⚡]			H [†]	T [†]
AT 456-5K26	3,802	98,560	165,880	17,660	(8) 20	746,800	22' 3-1/2"	12' 1/8"
AT 456-5L26	4,090	98,800	166,120	17,720	(8) 25	801,100	22' 3-1/2"	12' 1/8"
AT 456-5M26	4,335	99,200	166,520	17,820	(8) 30	848,200	22' 3-1/2"	12' 1/8"
AT 456-5N26	4,743	100,480	167,800	18,140	(8) 40	927,900	22' 3-1/2"	12' 1/8"
AT 456-5O26	5,075	100,560	167,880	18,160	(8) 50	994,400	22' 3-1/2"	12' 1/8"
SLSF Addition		9,600	9,600	1,200			1' 3-1/2"	1' 3-1/2"

- NOTE: (1) An adequately sized bleed line must be installed in the cooling tower system to prevent build-up of impurities in the recirculated water.
 (2) Do not use catalog drawings for certified prints. Dimensions and weights are subject to change.
 (3) Adequate spacing must be allowed for access to the cooling tower. Refer to EVAPCO's Equipment Layout Manual.
 (4) Nominal Tonnage is based on 3 gpm per ton at 95 degree entering water temperature, 85 degree leaving water temperature, and 78 degree wet-bulb temperature.

⚡ Outlet connection extends beyond bottom flange.
 † Height includes fan guard which ships factory mounted.

⚡ Heaviest section is upper section.

Drain Down Volume for Remote Sump Applications

The following chart provides the maximum drain down volume allowable per AT/UT/USS model number. Use this chart when sizing indoor or outdoor remote sumps tanks. Remote sump applications are commonly used whenever a cooling tower is idle during sub-freezing weather to protect the water in the basin from freezing or for large multi-tower industrial applications. Either application allows the circulating water to gravity drain into a remote sump tank indoors or a large, outdoor concrete basin located underneath the cooling tower.

The water volume provided is the cooling tower portion of the remote sump tank only. The tank should allow for drain down water from external piping and pump suction coverage.

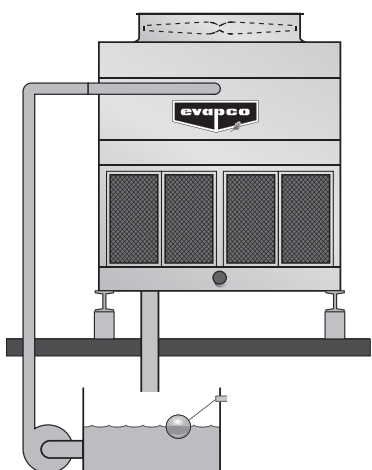

1-CELL	Box Size	Maximum Drain Down Volume (gal.)
	4 x 4	85
	4 x 6	130
	4 x 9	195
	4 x 12	275
	8.5 x 6	270
	8.5 x 7.5	320
	8.5 x 9	395
	8.5 x 10.5	460
	8.5 x 12	525
	8.5 x 14	610
	10 x 12	645
	10 x 18	980
	12 x 12	720
12 x 14	855	
12 x 18	1090	
12 x 20	1210	
14 x 24	1855	
14 x 26	2085	

	Box Size	Maximum Drain Down Volume (gal.)
2-CELL	6 x 17	540
	7.5 x 17	640
	12 x 9	540
	15 x 9	640
	17 x 9	790
	17 x 10.5	920
	17 x 12	1050
	17 x 14	1220
	8.5 x 18	790
	8.5 x 21	920
	8.5 x 24	1050
	8.5 x 28	1220
	10 x 24	1290
	10 x 36	1960
	12 x 24	1440
	12 x 28	1710
	12 x 36	2180
	12 x 40	2420
	14 x 48	3710
	14 x 52	4170
3-CELL	20 x 12	1290
	20 x 18	1960
	24 x 18	2180
	24 x 20	2420
	28 x 24	3710
	28 x 26	4170
	8.5 x 36	1575
	8.5 x 42	1830
	10 x 36	1935
	12 x 36	2160
	12 x 42	2565
	12 x 54	3270
12 x 60	3630	
14 x 72	5565	
14 x 78	6255	
42 x 26	6255	
4-CELL	24 x 24	2880
	24 x 28	3420
	24 x 36	4360
	24 x 40	4840
	28 x 48	7420
	28 x 52	8340
56 x 26	8340	

Optional Equipment: Electric Basin Heaters

Electric immersion heaters can be added to the basin of your Advanced Technology series cooling tower. They are sized to maintain a +40° F (4.5° C) pan water temperature with the fans and system pumps off. A thermostat and low-water protection device cycle the heater on when required and prevent the heater elements from energizing unless they are completely submerged. All components are protected by rugged, weatherproof enclosures for outdoor use.

AT/UT/USS Heater Sizes *

	Box Size	0°F kW	-20°F kW	-40°F kW
1-CELL	4 x 4	2	3	4
	4 x 6	3	4	5
	4 x 9	4	5	7
	4 x 12	5	7	9
	7 x 9	6	8	12
	7 x 12	(2) 4	(2) 6	(2) 8
	7 x 18	(2) 6	(2) 8	(2) 12
	8.5 x 6	5	7	9
	8.5 x 7.5	6	8	12
	8.5 x 9	7	10	15
8.5 x 10.5	8	12	15	
8.5 x 12	(2) 4	(2) 7	(2) 9	
8.5 x 14	(2) 5	(2) 7	(2) 10	
10 x 12	(2) 5	(2) 8	(2) 10	
10 x 18	(2) 7	(2) 12	(2) 15	
12 x 12	(2) 6	(2) 9	(2) 12	
12 x 14	(2) 7	(2) 10	(2) 15	
12 x 18	(2) 9	(2) 15	(2) 18	
12 x 20	(2) 10	(2) 15	(3) 15	
14 x 24	(2) 16	(3) 16	(3) 20	
14 x 26	(2) 16	(3) 16	(3) 20	
2-CELL	6 x 17	(2) 5	(2) 7	(2) 9
	7 x 24	(4) 4	(4) 6	(4) 8
	7 x 36	(4) 6	(4) 8	(4) 12
	7.5 x 17	(2) 6	(2) 8	(2) 12
	8.5 x 18	(2) 6	(2) 9	(2) 12
	8.5 x 21	(2) 7	(2) 12	(2) 15
	8.5 x 24	(4) 4	(4) 7	(4) 9
	8.5 x 28	(4) 5	(4) 7	(4) 10
	10 x 24	(4) 5	(4) 8	(4) 10
	10 x 36	(4) 7	(4) 12	(4) 15
	12 x 8.5	(2) 5	(2) 7	(2) 9
	12 x 24	(4) 6	(4) 9	(4) 12
	12 x 28	(4) 7	(4) 10	(4) 15
	12 x 36	(4) 9	(4) 15	(4) 18
	12 x 40	(4) 10	(4) 15	(4) 20
	14 x 48	(4) 16	**	**
	14 x 52	(4) 16	**	**
	14 x 9	(2) 6	(2) 8	(2) 12
	14 x 12	(4) 4	(4) 6	(4) 8
	14 x 18	(4) 6	(4) 8	(4) 12
15 x 8.5	(2) 6	(2) 8	(2) 12	
17 x 9	(2) 7	(2) 10	(2) 15	
17 x 10.5	(2) 8	(2) 12	(2) 15	
17 x 12	(4) 4	(4) 7	(4) 9	
17 x 14	(4) 5	(4) 7	(4) 10	
20 x 12	(4) 5	(4) 8	(4) 10	
20 x 18	(4) 7	(4) 12	(4) 15	
24 x 18	(4) 9	(4) 15	(4) 18	
24 x 20	(4) 10	(4) 15	(4) 20	
28 x 24	(4) 16	**	**	
28 x 26	(4) 16	**	**	

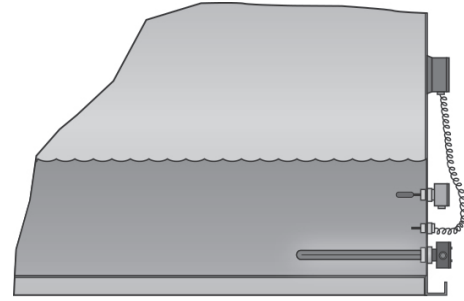

Note: Heater control packages that include contactor, transformer or disconnects are also available; speak to your local EVAPCO representative to learn more about these options.

AT/UT/USS Heater Sizes *

	Box Size	0°F kW	-20°F kW	-40°F kW
3-CELL	8.5 x 36	(6) 4	(6) 7	(6) 9
	8.5 x 42	(6) 5	(6) 7	(6) 10
	10 x 36	(6) 5	(6) 8	(6) 10
	12 x 36	(6) 6	(6) 9	(6) 12
	12 x 42	(6) 7	(6) 10	(6) 15
12 x 54	(6) 9	(6) 15	(6) 18	
12 x 60	(6) 10	(6) 15	(9) 15	
14 x 72	(6) 16	**	**	
14 x 78	(6) 16	**	**	
42 x 26	(6) 16	**	**	
4-CELL	24 x 24	(4) 12	(4) 18	(6) 15
	24 x 28	(4) 15	(4) 20	(6) 18
	24 x 36	(4) 18	(6) 18	(8) 18
	24 x 40	(4) 20	(6) 20	(8) 20
	28 x 48	(8) 16	**	**
	28 x 52	(8) 16	**	**
	56 x 26	(8) 16	**	**

* Electric heater selection based on ambient air temperature shown.

** Consult factory

Optional Equipment: Low Sound Solutions

Low Sound Fan – 4-7 dB(A) Reduction

Ideal for sound-sensitive applications, EVAPCO's low sound fan features a wide chord blade and a unique soft-connect blade-to-hub design that is compatible with variable speed drives. Since the blades are not rigidly connected to the fan hub, no vertical vibration forces are transmitted to the unit structure. This reduces sound pressure levels by 4 to 7 dB(A), depending on specific unit selection and measurement location.

The fan is a high efficiency axial propeller and is CTI certified on Advanced Technology series cooling towers. It has a thermal performance derate of 3.5%. Consult your EVAPCO representative for actual thermal performance. *Note: Available on AT and USS models only.*

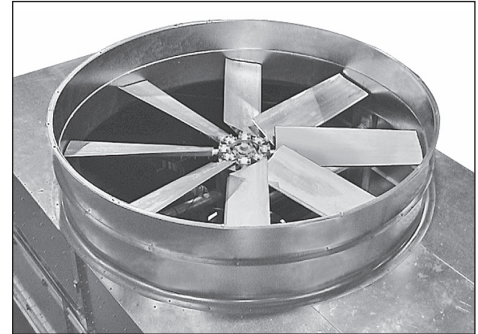

Additional Height & Operating Weight Additions

	Box Size	Height Addition for Low Sound Fan (in.)	Operating Weight Addition for Low Sound Fan (lbs.)
1-CELL	4 x 4	0	0
	4 x 6	0	0
	4 x 9	0	0
	4 x 12	0	0
	7 x 9	4	0
	7 x 12	4	0
	7 x 18	4	0
	8.5 x 6	4	0
	8.5 x 7.5	4	0
	8.5 x 9	4	0
	8.5 x 10.5	4	0
	8.5 x 12	4	0
	8.5 x 14	4	0
	10 x 12	0	0
10 x 18	0	0	
2-CELL	12 x 12	0	0
	12 x 14	0	0
	12 x 18	7	225
	12 x 20	7	225
	14 x 24	5	450
	14 x 26	7	450
	6 x 17	4	0
	7 x 24	4	0
	7 x 36	4	0
	7.5 x 17	4	0
	8.5 x 18	4	0
	8.5 x 21	4	0
	8.5 x 24	4	0
	8.5 x 28	4	0
10 x 24	0	0	
10 x 36	0	0	
12 x 8.5	4	0	
12 x 24	0	0	
12 x 28	0	0	
12 x 36	7	450	
12 x 40	7	450	
14 x 48	5	900	
14 x 52	7	900	

	Box Size	Height Addition for Low Sound Fan (in.)	Operating Weight Addition for Low Sound Fan (lbs.)
2-CELL	14 x 9	4	0
	14 x 12	4	0
	14 x 18	4	0
	15 x 8.5	4	0
	17 x 9	4	0
	17 x 10.5	4	0
	17 x 12	4	0
	17 x 14	4	0
	20 x 12	0	0
	20 x 18	0	0
3-CELL	24 x 18	7	450
	24 x 20	7	450
	28 x 24	5	900
	28 x 26	7	900
	8.5 x 36	4	0
	8.5 x 42	4	0
	10 x 36	0	0
	12 x 36	0	0
	12 x 42	0	0
	12 x 54	7	675
12 x 60	7	675	
4-CELL	14 x 72	5	1,350
	14 x 78	7	1,350
	42 x 26	7	1,350
	24 x 24	0	0
	24 x 28	0	0
	24 x 36	7	900
	24 x 40	7	900
	28 x 48	5	1,800
	28 x 52	7	1,800
	56 x 26	7	1,800

Structural Steel Support

Models AT/UT/USS 14-2E4 to 314-5O78

Suggested Two I-Beam Arrangement

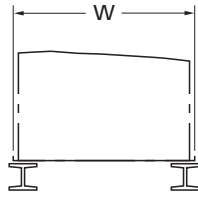

End Elevation

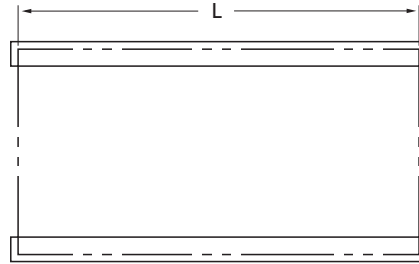

Plan View

Box Sizes 4' x 4' through 8.5' x 18'

Two I-Beams Required (By Others)

	Box Size	Dimensions	
		W	L
1-CELL	4 x 4	4' 0-15/32"	3' 11-5/8"
	4 x 6	4' 0-15/32"	5' 11-5/8"
	4 x 9	4' 0-15/32"	8' 11-11/16"
	4 x 12	4' 0-15/32"	11' 11-5/8"
	7 x 9	7' 4"	8' 11-1/2"
	7 x 12	7' 4"	11' 11-3/4"
	7 x 18	7' 4"	18' 0"
	8.5 x 6	5' 11-7/8"	8' 5-1/2"
	8.5 x 7.5	7' 5-7/8"	8' 5-1/2"
	8.5 x 9	8' 5-1/2"	8' 11-1/2"
	8.5 x 10.5	8' 5-1/2"	10' 5-1/2"
	8.5 x 12	8' 5-1/2"	11' 11-3/4"
	8.5 x 14	8' 5-1/2"	13' 11-3/4"
	10 x 12	9' 9-3/4"	11' 11-3/4"
	10 x 18	9' 9-3/4"	18' 0"
	12 x 12	11' 10"	11' 11-3/4"
	12 x 14	11' 10"	13' 11-3/4"
12 x 18	11' 10"	18' 0"	
12 x 20	11' 10"	20' 0"	
14 x 24	13' 11-1/4"	23' 9"	
14 x 26	13' 11-1/4"	25' 8-7/8"	
2-CELL	6 x 17	5' 11-7/8"	17' 1-1/2"
	7.5 x 17	7' 5-7/8"	17' 1-1/2"
	8.5 x 18	8' 5-1/2"	18' 0"

Box Sizes 8.5' x 21' through 14' x 78'

Two I-Beams Required (By Others)

	Box Size	Dimensions	
		W	L
2-CELL	7 x 24	7' 4"	24' 2"
	7 x 36	7' 4"	36' 2-1/2"
	8.5 x 21	8' 5-1/2"	21' 0"
	8.5 x 24	8' 5-1/2"	24' 2"
	8.5 x 28	8' 5-1/2"	28' 2"
	10 x 24	9' 9-3/4"	24' 2"
	10 x 36	9' 9-3/4"	36' 2-1/2"
	12 x 24	11' 10"	24' 2"
	12 x 28	11' 10"	28' 2"
	12 x 36	11' 10"	36' 2-1/2"
	12 x 40	11' 10"	40' 2-1/4"
	14 x 48	13' 11-1/4"	47' 8-1/2"
	14 x 52	13' 11-1/4"	51' 8-1/4"
	3-CELL	8.5 x 36	8' 5-1/2"
8.5 x 42		8' 5-1/2"	42' 4-1/4"
10 x 36		9' 9-3/4"	36' 4-1/4"
12 x 36		11' 10"	36' 4-1/4"
12 x 42		11' 10"	42' 4-1/4"
12 x 54		11' 10"	54' 5"
12 x 60		11' 10"	60' 5"
14 x 72		13' 11-1/4"	71' 8"
14 x 78	13' 11-1/4"	77' 7-5/8"	

Notes:

Models Listed Above.

- These are suggested arrangements for preliminary layout purposes. Consult your EVAPCO representative for factory certified steel support drawings.
- The recommended support for the AT/UT/USS Cooling Tower is structural I-beams located under the outer flanges and running the entire length of the unit. The unit should be elevated to allow access underneath the unit and to the roof below. Mounting holes, 3/4" in diameter, are located in the bottom flanges of the pan to provide for bolting to the structural steel.
- Beams should be sized in accordance with accepted structural practices. Maximum deflection of beam under unit to be 1/360 of the unit length, not to exceed 1/2".
- For these models where two support beams are required, deflection may be calculated by using 55% of the operating weight as a uniform load on each beam.
- Beams should be level before setting the unit in place. Do not level the unit by shimming between it and the I-beams.
- Support beams and Anchor bolts are to be furnished by others.
- Dimensions, weights and data are subject to change without notice. Refer to the factory certified drawings for exact dimensions.
- For alternate layout arrangements please consult the factory. **NOTE: OPTIONAL BOTTOM CONNECTIONS WILL REQUIRE THE UNIT TO BE ELEVATED TO ALLOW FOR PIPING.**

Structural Steel Support

Models AT/UT/USS 212-2G9 to 428-5052

Suggested Three I-Beam Arrangement

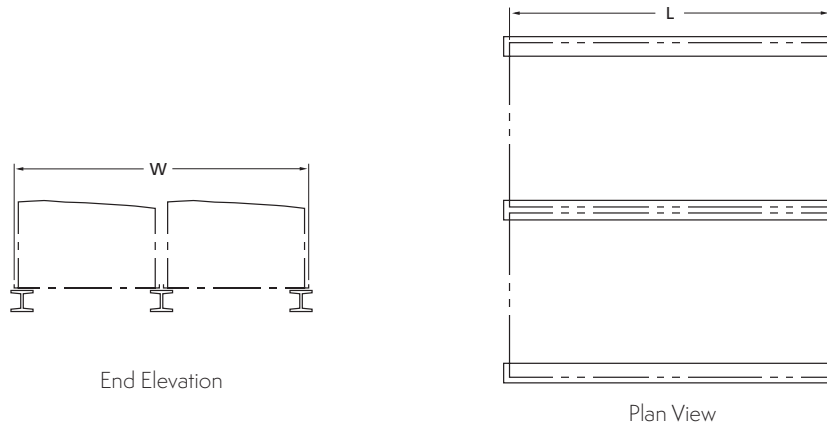

Box Sizes 12' x 7.5' through 28' x 52'

Three I-Beams Required (By Others)

	Box Size	Dimensions	
		W	L
2-CELL	12 x 8.5	12' 4-7/8"	8' 5-1/2"
	14 x 9	15' 1-1/8"	8' 11-1/2"
	14 x 12	15' 1-1/8"	11' 11-3/4"
	14 x 18	15' 1-1/8"	18' 0"
	15 x 7.5	15' 4-7/8"	8' 5-1/2"
	17 x 9	17' 4-1/8"	8' 11-1/2"
	17 x 10.5	17' 4-1/8"	10' 5-1/2"
	17 x 12	17' 4-1/8"	11' 11-3/4"
	17 x 14	17' 4-1/8"	13' 11-3/4"
	20 x 12	20' 0-5/8"	11' 11-3/4"
	20 x 18	20' 0-5/8"	18' 0"
	24 x 18	24' 1-1/8"	18' 0"
	24 x 20	24' 1-1/8"	20' 0"
	28 x 24	28' 3-5/8"	23' 9"
4-CELL	28 x 26	28' 3-5/8"	25' 8-7/8"
	24 x 24	24' 1-1/8"	24' 1-3/4"
	24 x 28	24' 1-1/8"	28' 1-3/4"
	24 x 36	24' 1-1/8"	36' 2-1/4"
	24 x 40	24' 1-1/8"	40' 2-1/4"
	28 x 48	28' 3-5/8"	51' 1"
	28 x 52	28' 3-5/8"	55' 3/4"

Notes:

Models Listed Above.

- These are suggested arrangements for preliminary layout purposes. Consult your EVAPCO representative for factory certified steel support drawings.
- The recommended support for the AT/UT/USS Cooling Tower is structural I-beams located under the outer flanges and running the entire length of the unit. The unit should be elevated to allow access underneath the unit and to the roof below. Mounting holes, 3/4" in diameter are located in the bottom flanges of the pan to provide for bolting to the structural steel.
- Beams should be sized in accordance with accepted structural practices. Maximum deflection of beam under unit to be 1/360 of the unit length, not to exceed 1/2".
- For these models only where three support beams are required, deflection may be calculated using 56% of the operating weight on the CENTER BEAM and 22% on each OUTBOARD beam.
- Beams should be level before setting the unit in place. Do not level the unit by shimming between it and the I-beams.
- Support beams and Anchor bolts are to be furnished by others.
- Dimensions, weights and data are subject to change without notice. Refer to the factory certified drawings for exact dimensions.
- For alternate layout arrangements please consult the factory. NOTE: OPTIONAL BOTTOM CONNECTIONS WILL REQUIRE THE UNIT TO BE ELEVATED TO ALLOW FOR PIPING.

Structural Steel Support

Models AT/UT/USS 342-5K26 to 342-5O26 Suggested Four I-Beam Arrangement

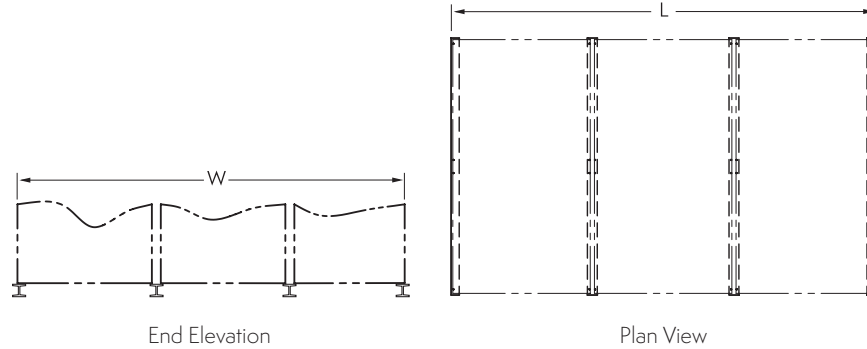

Models AT/UT/USS 456-5K26 to 456-5O26 Suggested Five I-Beam Arrangement

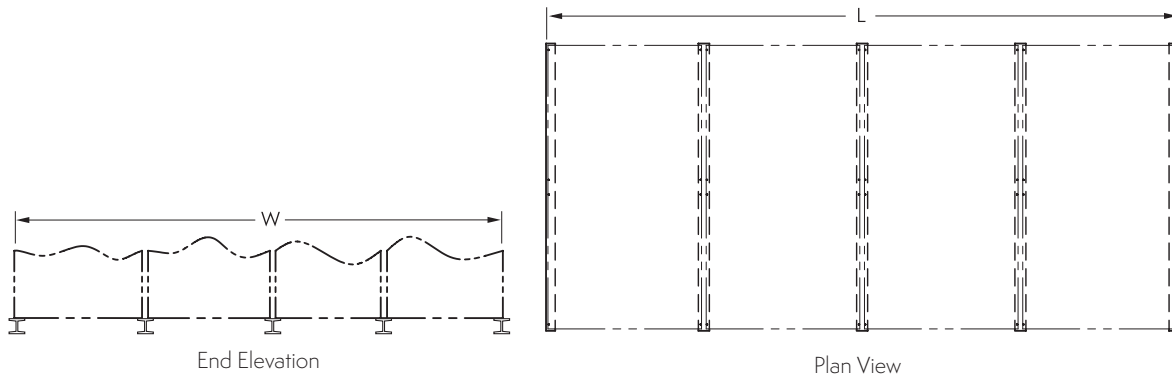

Box Size 42' x 26' through 56' x 26'

I-Beams Required (By Others)

Dimensions		
Box Size	W	L
42 x 26	42' 8"	25' 8-7/8"
56 x 26	57' 3/8"	25' 8-7/8"

Notes:

Models Listed Above.

1. These are suggested arrangements for preliminary layout purposes. Consult your EVAPCO representative for factory certified steel support drawings.
2. The recommended support for the AT/UT/USS Cooling Tower is structural I-beams located under the outer flanges and running the entire length of the unit. The unit should be elevated to allow access underneath the unit and to the roof below. Mounting holes, 3/4" in diameter are located in the bottom flanges of the pan to provide for bolting to the structural steel.
3. Beams should be sized in accordance with accepted structural practices. Maximum deflection of beam under unit to be 1/360 of the unit length, not to exceed 1/2".
4. For these models only where four or five support beams are required, deflection may be calculated using 56% of the operating weight on the CENTER BEAMS and 22% on each OUTBOARD beam.
5. Beams should be level before setting the unit in place. Do not level the unit by shimming between it and the I-beams.
6. Support beams and Anchor bolts are to be furnished by others.
7. Dimensions, weights and data are subject to change without notice. Refer to the factory certified drawings for exact dimensions.
8. For alternate layout arrangements please consult the factory. *NOTE: OPTIONAL BOTTOM CONNECTIONS WILL REQUIRE THE UNIT TO BE ELEVATED TO ALLOW FOR PIPING.*

Applications

Design

EVAPCO Cooling towers are of heavy-duty construction and designed for long trouble-free operation. Proper equipment selection, installation and maintenance are necessary to ensure full unit performance while maximizing the equipment's service life. Some of the major considerations in the application of a tower are presented below. For additional information, please contact the factory.

Piping

Cooling tower piping should be designed and installed in accordance with generally accepted engineering practices. All piping should be anchored by properly designed hangers and supports with allowance made for possible expansion and contraction. No external loads should be placed upon cooling tower connections, nor should any of the piping supports be anchored to the unit framework.

The piping connection locations shown on the drawings included in this catalog and on the website are standard locations that can be changed. If the piping connection locations shown do not meet the needs of a particular project, contact the factory to determine a viable solution.

Air Circulation

In reviewing the system design and unit location, it is important that enough fresh air is provided to enable proper unit performance. The best location is on an unobstructed roof top or at ground level away from walls and other barriers. Care must be taken when locating towers in wells or enclosures or next to high walls. The potential for recirculation of the hot, moist discharge air back into the fan intake exists. Recirculation raises the wetbulb temperature of the entering air, causing the leaving water temperature to rise above the design conditions. For these cases, the overall unit height should be raised so it is even with the adjacent wall, reducing the chance of recirculation. This can be done by raising the entire unit or adding a discharge hood. For additional information, see the EVAPCO Equipment Layout Manual. Engineering Assistance is also available from the factory to identify potential recirculation problems and recommend solutions, such as re-orienting multi-cell units.

Design Flexibility and Assistance

The large number of EVAPCO AT Cooling towers makes it easy to find a model to meet your design and layout needs. If there is an application for which the standard catalog product line does not work, EVAPCO will make a cooling tower that will fit your requirement. Consult your local EVAPCO Representative or the factory for assistance with Applications, Layout, Accessories or other design needs.

Water Treatment

Proper water treatment is an essential part of the maintenance required for all evaporative cooling equipment. A well designed and consistently implemented water treatment program will help to ensure efficient system operation while maximizing the equipment's service life. A qualified water treatment company should design a site specific water treatment protocol based on equipment (including all metallurgies in the cooling system), location, makeup water quality and usage.

Without proper water treatment, the equipment can be susceptible to scale build-up on its heat exchange surfaces, biological growth in the recirculating water and corrosion of its components. Your site specific water treatment protocol should include procedures for routine operation, startup after a shut-down period, and system lay-up, if applicable.

Passivation Period

If the equipment includes any galvanized components, the initial commissioning and passivation period is a critical time for maximizing the service life of galvanized equipment. Evapco recommends that a site specific water treatment protocol which includes a passivation procedure that details the desired water chemistry and visual inspections during the first six to twelve weeks of operation be used. During this passivation period, recirculating water pH should be maintained above 7.0 and below 8.0 at all times.

Recirculating Water System

The cooling in a tower is accomplished by the evaporation of a portion of the recirculated spray water. As this water evaporates, it leaves behind mineral content and impurities. Therefore, it is important to bleed-off an amount of water proportional to that which is evaporated to prevent the buildup of impurities. If this is not done, the mineral content and/or the corrosive nature of the water will continue to increase. This can ultimately result in heavy scaling or a corrosive condition.

Bleed-off

Evaporative cooling equipment requires a bleed or blow-down line to remove concentrated water from the system. The mineral concentration is monitored by measuring the conductivity of the water. Evapco recommends an automated conductivity controller to maximize the water efficiency of your system. Based on recommendations from your water treatment supplier, the conductivity controller should open and close a bleed valve to maintain the conductivity of the recirculating water.

Control of Biological Contaminants

Evaporative cooling equipment should be inspected regularly to ensure good microbiological control. Inspections should include both monitoring of microbial populations via culturing techniques and visual inspections for evidence of biofouling. Poor microbiological control can result in loss of heat transfer efficiency, increase corrosion potential, and increase the risk of pathogens such as those that can cause risk to health. If excessive microbiological contamination is detected, a more aggressive mechanical cleaning and/or water treatment program should be undertaken.

Sample Mechanical Specification

SECTION 23 65 00 COOLING TOWERS

Below specification applies for a base AT unit with no options or accessories selected. For a copy of a dynamic specification, please contact your EVAPCO Sales Representative for access to EVAPCO's **SPECTRUM** selection software.

PART 1 - GENERAL

1.1 RELATED DOCUMENTS

A. Drawings and general provisions of the Contract, including General and Supplementary Conditions and Division 01 Specification Sections, apply to this Section.

1.2 SUMMARY

A. This Section includes factory assembled and tested, open circuit mechanical induceddraft vertical discharge cooling tower.

1.3 SUBMITTALS

A. Product Data: For each type of product indicated. Include rated capacities, pressure drop, performance curves with selected points indicated, furnished specialties, and accessories.

B. Shop Drawings: Complete set of manufacturer's prints of equipment assemblies, control panels, sections and elevations, and unit isolation. Include the following:

1. Assembled unit dimensions.
2. Weight and load distribution.
3. Required clearances for maintenance and operation.
4. Sizes and locations of piping and wiring connections.
5. Wiring Diagrams: For power, signal, and control wiring. Differentiate between manufacturer installed and field installed wiring.

C. Operation and Maintenance Data: Each unit to include operation and maintenance manual.

1.4 QUALITY ASSURANCE

A. Verification of Performance:

1. The thermal performance shall be certified by the Cooling Technology Institute in accordance with CTI Certification Standard STD-201. Lacking such certification, a field acceptance test shall be conducted within the warranty period in accordance with CTI Acceptance Test Code ATC-105, by a Certified CTI Thermal Testing Agency. The Evaporative Heat Rejection Equipment shall comply with the energy efficiency requirements of ASHRAE Standard 90.1.
2. Unit Sound Performance ratings shall be tested according to CTI ATC-128 standard. Sound ratings shall not exceed specified ratings.

B. Unit shall meet or exceed energy efficiency per ASHRAE 90.1

1.5 WARRANTY

A. Submit a written warranty executed by the manufacturer, agreeing to repair or replace components of the unit that fail in materials and workmanship within the specified warranty period.

1. The Entire Unit shall have a comprehensive one (1) year warranty against defects in materials and workmanship from startup, not to exceed eighteen (18) month from shipment of the unit.

2. Fan Motor/Drive System: Warranty Period shall be Five (5) years from date of unit shipment from Factory (fan motor(s), fan(s), bearings, mechanical support, sheaves, bushings and belt(s)).

PART 2 - PRODUCTS

2.1 MANUFACTURERS

A. Manufacturers: Subject to compliance with requirements, provide cooling towers manufactured by one of the following:

1. EVAPCO Model AT _____
2. Approved Substitute

2.2 THERMAL PERFORMANCE

A. Each unit shall be capable to cool _____ GPM of water entering at _____ ° F leaving at _____ ° F at a design wet bulb of _____ ° F.

2.3 IBC COMPLIANCE

A. The unit structure shall be designed, analyzed, and constructed in accordance with the latest edition of International Building Code (IBC) for: IP = 1.0, SDS = 1.34; z/h = 0, P = 119 psf.

2.4 COMPONENTS

A. Description: Factory assembled and tested, induced draft counter flow cooling tower complete with fan, fill, louvers, accessories and rigging supports

B. Materials of Construction

1. All cold water basin components including vertical supports, air inlet louver frames and panels up to rigging seam shall be constructed of heavy gauge mill hot-dip galvanized steel.
2. Upper Casing, channels and angle supports shall be constructed of heavy gauge mill hot-dip galvanized steel. Fan cowl and guard shall be constructed of galvanized steel. All galvanized steel shall be coated with a minimum of 2.35 ounces of zinc per square foot of area (G-235 Hot-Dip Galvanized Steel designation). During fabrication, all galvanized steel panel edges shall be coated with a 95% pure zinc-rich compound.

C. Fan(s):

1. Fan(s) shall be high efficiency axial propeller type with aluminum wide chord blade construction. Each fan shall be dynamically balanced and installed in a closely fitted cowl with venturi air inlet for maximum fan efficiency.

D. Drift Eliminators

1. Drift eliminators shall be constructed entirely of Polyvinyl Chloride (PVC) in easily handled sections. Design shall incorporate three changes in air direction and limit the water carryover to a maximum of 0.001% of the recirculating water rate.

Sample Mechanical Specification

E. Water Distribution System

1. Spray nozzles shall be precision molded ABS, large orifice nozzles utilizing fluidic technology for superior water distribution over the fill media. Nozzles shall be designed to minimize water distribution system maintenance. Spray header and branches shall be Schedule 40 Polyvinyl Chloride (PVC) for corrosion resistance with a steel connection to attach external piping.

F. Heat Transfer Media

1. Fill media shall be constructed of Polyvinyl Chloride (PVC) of cross-fluted design and suitable for inlet water temperatures up to 130° F. The bonded block fill shall be bottom supported and suitable as an internal working platform. Fill shall be self-extinguishing, have a flame spread of 5 under A.S.T.M. designation E-84-81a, and shall be resistant to rot, decay and biological attack.

G. Air Inlet Louvers

1. The air inlet louver screens shall be constructed from UV inhibited polyvinyl chloride (PVC) and incorporate a framed interlocking design that allows for easy removal of louver screens for access to the entire basin area for maintenance. The louver screens shall have a minimum of two changes in air direction and shall be of a non-planar design to prevent splash-out and block direct sunlight & debris from entering the basin.

H. Make up Float Valve Assembly

1. Make up float assembly shall be a mechanical brass valve with an adjustable plastic float.

I. Pan Strainer

1. Pan Strainer(s) shall be all Type 304 Stainless Steel construction with large area removable perforated screens.

2.5 MOTORS AND DRIVES

A. General requirements for motors are specified in Division 23 Section "Motors"

B. Fan Motor

1. Fan motor(s) shall be totally enclosed, ball bearing type electric motor(s) suitable for moist air service. Motor(s) are Premium Efficient, Class F insulated, 1.15 service factor design. Inverter rated per NEMA MG1 Part 31.4.4.2 and suitable for variable torque applications and constant torque speed range with properly sized and adjusted variable frequency drives.

2. Fan motor(s) shall include strip-type space heaters with separate leads brought to the motor conduit box.

C. Fan Drive

1. The fan drive shall be multigroove, solid back V-belt type with QD tapered bushings designed for 150% of the motor nameplate power. The belt material shall be neoprene reinforced with polyester cord and specifically designed for evaporative equipment service. Fan sheave shall be aluminum alloy construction. Belt adjustment shall be accomplished from the exterior of the unit.

D. Fan Shaft

1. Fan shaft shall be solid, ground and polished steel. Exposed surface shall be coated with rust preventative.

E. Fan Shaft Bearings

1. Fan Shaft Bearings shall be heavy-duty, self-aligning ball type bearings with extended lubrication lines to grease fittings located on access door frame. Bearings shall be designed for a minimum L-10 life of 100,000 hours.

2.6 MAINTENANCE ACCESS

A. Fan Section

1. Access door shall be hinged and located in the fan section for fan drive and water distribution system access.

B. Basin Section

1. Framed removable louver panels shall be on all four (4) sides of the unit for pan and sump access.

C. Internal Working Platform

1. Internal working platform shall provide easy access to the fans, belts, motors, sheaves, bearings, all mechanical equipment and complete water distribution system. The fill shall be an acceptable means of accessing these components.

D. Louver Access Door

1. Hinged access door in louver shall be provided.



OUR PRODUCTS ARE MANUFACTURED WORLDWIDE.



★ World Headquarters/ Research and Development Center
■ EVAPCO Facilities

EVAPCO, Inc. — World Headquarters & Research / Development Center

P.O. Box 1300 • Westminster, MD 21158 USA
410-756-2600 p • marketing@evapco.com • evapco.com

North America

EVAPCO, Inc. World Headquarters
P.O. Box 1300
Westminster, MD 21158 USA
410-756-2600 p | 410-756-6450 f
marketing@evapco.com

EVAPCO East
5151 Allendale Lane
Taneytown, MD 21787 USA
410-756-2600 p | 410-756-6450 f
marketing@evapco.com

EVAPCO East Key Building
Taneytown, MD USA
410-756-2600 p
marketing@evapco.com

EVAPCO Midwest
Greenup, IL USA
217-923-3431 p
evapcomw@evapcomw.com

EVAPCO West
Madera, CA USA
559-673-2207 p
contact@evapcwest.com

EVAPCO Iowa
Lake View, IA USA
712-657-3223 p

EVAPCO Iowa Sales & Engineering
Medford, MN USA
507-446-8005 p
evapcomn@evapcomn.com

EVAPCO Newton
Newton, IL USA
618-783-3433 p
evapcomw@evapcomw.com

EVAPCOLD
Greenup, IL USA
217-923-3431 p
evapcomw@evapcomw.com

EVAPCO-BLCT Dry Cooling, Inc.
1011 US Highway 22 West
Bridgewater, NJ 08807 USA
Phone: 1-908-379-2665
E-mail: info@evapco-blct.com

EVAPCO-BLCT Dry Cooling, Inc.
7991 Shaffer Parkway
Littleton, CO 80127 USA
Phone: 1-908-379-2665
E-mail: info@evapco-blct.com
Spare Parts Phone: 908-895-3236
Spare Parts e-mail: spares@evapco-blct.com

EVAPCO Power México S. de RL. de C.V.
Calle Iglesia No. 2, Torre E
Tizapan San Ángel, Del. Álvaro Obregón
Ciudad de México, D.F. México 01090
Phone: +52 (55) 8421-9260
e-mail: info@evapco-blct.com

Refrigeration Valves & Systems Corporation
A wholly owned subsidiary of EVAPCO, Inc.
Bryan, TX USA
979-778-0095 p
rvs@rvscorp.com

EvapTech, Inc.
A wholly owned subsidiary of EVAPCO, Inc.
Lenexa, KS USA
913-322-5165 p
marketing@evaptech.com

Tower Components, Inc.
A wholly owned subsidiary of EVAPCO, Inc.
Ramsour, NC USA
336-824-2102 p
mail@towercomponentsinc.com

EVAPCO Alcoil, Inc.
A wholly owned subsidiary of EVAPCO, Inc.
York, PA USA
717-347-7500 p
info@alcoil.net

Europe

EVAPCO Europe BVBA European Headquarters
Heersterveldweg 19
Industrieterrein Oost
3700 Tongeren, Belgium
(32) 12-395029 p | (32) 12-238527 f
evapco.europe@evapco.be

EVAPCO Europe, S.r.l.
Milan, Italy
(39) 02-939-9041 p
evapcoeuropa@evapco.it

EVAPCO Europe, S.r.l.
Sondrio, Italy

EVAPCO Europe GmbH
Meerbusch, Germany
(49) 2159 6956 18 p
info@evapco.de

EVAPCO Air Solutions
A wholly owned subsidiary of EVAPCO, Inc.
Aabybro, Denmark
(45) 9824 4999 p
info@evapco.dk

EVAPCO Air Solutions GmbH
Garbsen, Germany
(49) 5137 93875-0 p
info@evapcoas.de

Evap Egypt Engineering Industries Co.
A licensed manufacturer of EVAPCO, Inc.
Nasr City, Cairo, Egypt
2 02 24022866 / 2 02 24044997 p
primacool@link.net / shady@primacool.net

EVAPCO S.A. (Pty.) Ltd.
A licensed manufacturer of EVAPCO, Inc.
Isando 1600, Republic of South Africa
(27) 11-392-6630 p
evapco@evapco.co.za

Asia/Pacific

EVAPCO Asia/Pacific Headquarters
1159 Luoning Road
Baoshan Industrial Zone
Shanghai 200949, P.R. China
(86) 21-6687-7786 p | (86) 21-6687-7008 f
marketing@evapcochina.com

EVAPCO (Shanghai) Refrigeration Equipment Co., Ltd.
Baoshan Industrial Zone Shanghai, P.R. China
(86) 21-6687-7786 p
marketing@evapcochina.com

Beijing EVAPCO Refrigeration Equipment Co., Ltd.
Huairou District Beijing, P.R. China
010-6166-7238 p
evapcobj@evapcochina.com

EVAPCO Australia (Pty.) Ltd.
Riverstone NSW 2765, Australia
(61) 2 9627-3322 p
sales@evapco.com.au

EVAPCO Composites Sdn. Bhd
Rawang, Selangor, Malaysia
(60-3) 6092-2209 p

EvapTech Asia Pacific Sdn. Bhd
A wholly owned subsidiary of EvapTech, Inc.
Puchong, Selangor, Malaysia
(60-3) 8070-7255 p
marketing-ap@evaptech.com

South America

EVAPCO Brasil
Equipamentos Industriais Ltda.
Al. Vênus, 151 – CEP: 13347-659
Indaiatuba – São Paulo – Brasil
(55+11) 5681-2000 p
vendas@evapco.com.br

Fan Technology Resource
Cruz das Almas – Indaiatuba
São Paulo, Brasil 13308-200
55 (11) 4025-1670
fantr@fantr.com

www.evapco-blct.com

