

**Trailblazer®**  
**Air-Cooled Scroll Compressor Chillers**  
**With High Efficiency Variable Speed Fan Technology**

**Model AGZ-E**  
**030 to 241 Tons (100 to 840 kW)**  
**HFC-410A Refrigerant**  
**60/50 Hz**



<b>Introduction</b> . . . . .	<b>3</b>
<b>Features and Benefits</b> . . . . .	<b>4</b>
<b>Application Considerations</b> . . . . .	<b>7</b>
<b>Sound Data</b> . . . . .	<b>16</b>
<b>Pressure Drop Data</b> . . . . .	<b>22</b>
<b>Physical Data - Packaged Unit</b> . . . . .	<b>25</b>
<b>Dimensions and Weights - Packaged Units</b> . . . . .	<b>29</b>
<b>Isolators</b> . . . . .	<b>43</b>
<b>Electrical Data</b> . . . . .	<b>44</b>
<b>Options and Accessories</b> . . . . .	<b>55</b>
<b>Engineering Guide Specifications</b> . . . . .	<b>58</b>

Manufactured in an ISO 9001 & ISO 14001 certified facility



\*Remote Evaporator and Heat Recovery options outside the scope of AHRI ACCL Certification Program.



©2018 Daikin Applied. Illustrations and data cover the Daikin Applied product at the time of publication and we reserve the right to make changes in design and construction at any time without notice.



## Air-Cooled Chiller Products

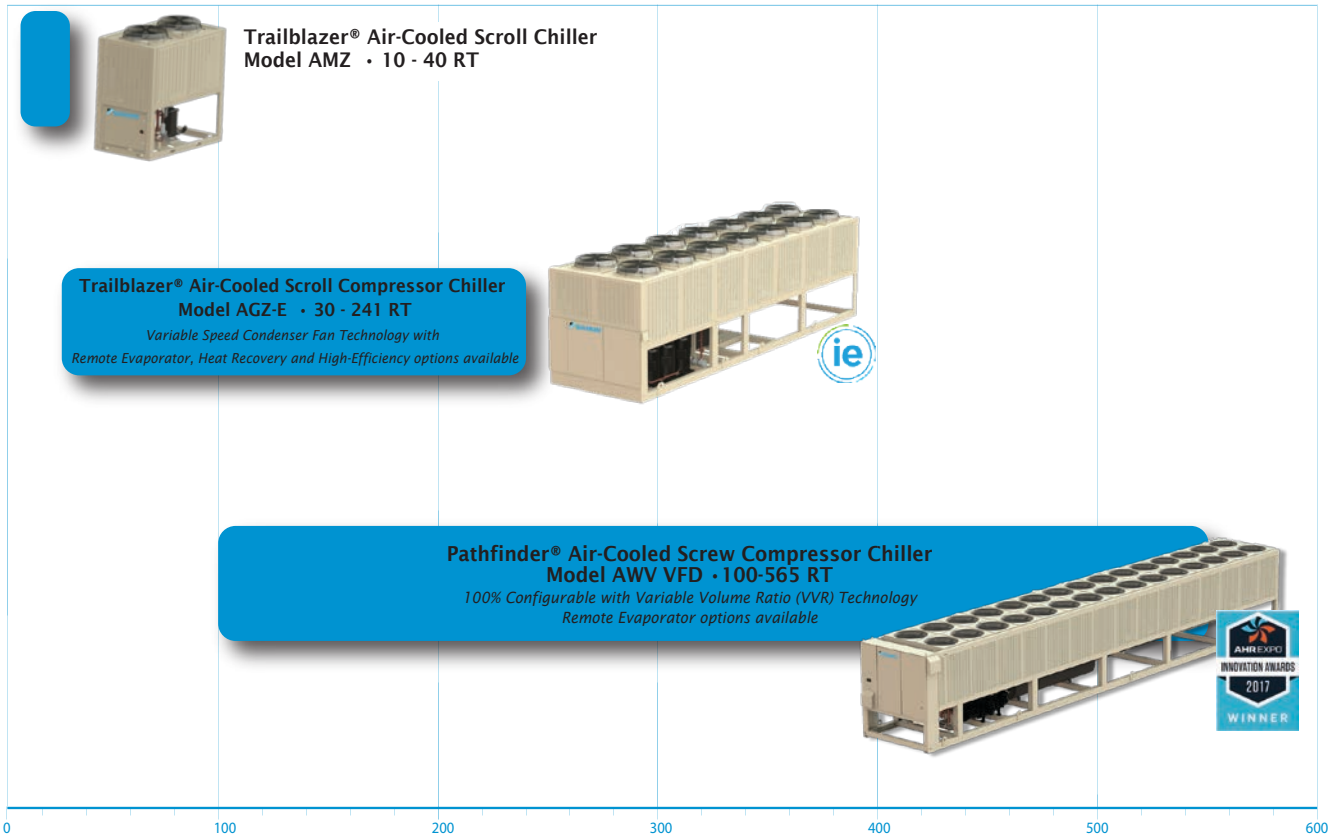

The Trailblazer® family of air-cooled scroll chillers continues the Daikin Applied legacy of high quality, high efficiency, latest technology and quiet operation. These features make the Trailblazer® family the best overall value in air-cooled packaged chillers available today. The Trailblazer® series offers a wide selection of units from 30 to 241 tons with dual refrigerant circuits available as packaged units with optional heat recovery or pump packages, or as remote evaporators.

### Efficient Operation

The Trailblazer® units utilize environmentally acceptable R-410A refrigerant and meet the performance requirements of ASHRAE Standard 90.1 for efficiency. Excellent part-load performance is achieved with four or six scroll compressors. A variable speed condenser fan option is also available to provide even higher part load efficiency. High overall efficiency = lower annual energy costs.

### RapidRestore® and Fast Loading

When power has been interrupted, the Trailblazer® has the capability to restore cooling quickly by using RapidRestore® and Fast Loading. These options make Trailblazer® ideal for mission critical buildings, data centers, healthcare facilities, and manufacturing processes. Once power is restored after a power loss duration of up to 180 seconds, the time for a Trailblazer® chiller to restart is less than 125 seconds with the chiller reaching full load within 220 seconds.

### Application Flexibility

Trailblazer® units are available as packaged chillers with optional heat recovery or pump packages, as well as remote evaporator configurations. Information on remote evaporator models and factory-installed pump packages can be found in a separate installation manual available on [www.DaikinApplied.com](http://www.DaikinApplied.com).

### Quiet Operation

The Trailblazer® units live up to the Daikin Applied reputation for low operating sound levels and make these chillers “neighborhood friendly.” Full load sound pressure levels as low as 60 dB without insulation.

### LEED® Points

For building owners who wish to pursue Leadership in Energy and Environmental Design (LEED®) Green Building Certification, points earned for Optimize Energy Performance (formerly EA Credit 1) are awarded based on overall building efficiency. The high efficiency of the AGZ-E will contribute to the total points earned for this credit. Trailblazer® chillers can also contribute to Enhanced Refrigerant Management (formerly EA Credit 4) qualification which is partially determined by tonnage and refrigerant quantity. Consult with your Daikin Applied sales representative for more information.

## CHILLER NOMENCLATURE

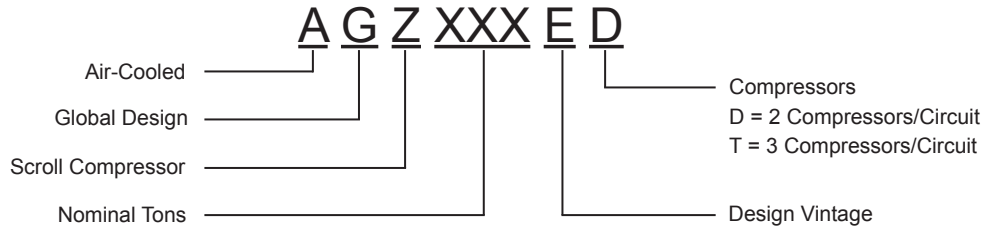

### Unit Design Features

Daikin Trailblazer® air-cooled chillers are a product of our commitment to offer quiet, reliable, energy efficient equipment, incorporating high quality compressors, and innovative packaging.

### Construction

Trailblazer® chillers are factory-assembled and mounted on a heavy-gauge steel base. The base distributes the unit weight for roof loading. Their small footprint allows smaller mounting pads or support structures and is a plus for retrofit or replacement applications.

### Compressors

Reliable hermetic scroll compressors with cast iron scrolls and three Teflon® impregnated bearings are used on the Trailblazer® chillers to promote longevity.

Each model has the ability to modulate its capacity. Models with four compressors will have four steps of capacity modulation while models with six compressors will have six steps. Compressors stage on depending on the load of the system. This results in excellent part-load efficiency and reduced annual operating costs.

Features include motor temperature protection, scroll temperature protection, missing phase protection, reverse phase protection, low control circuit voltage protection, short cycling detection and alert, Modbus® communication to system controller, operational and fault history storage, and LED status display.

### Evaporator

Trailblazer® units are designed to maximize efficiency in the smallest possible footprint. The evaporator is a compact, high efficiency, dual circuit, brazed plate-to-plate type heat exchanger consisting of parallel stainless steel plates. These heat exchangers provide excellent heat exchange efficiency in a compact footprint and are especially attractive for smaller capacity units. Evaporators are designed and constructed according to, and listed by, Underwriters Laboratories (UL).

### Optional Remote Evaporator

Units 30-241 tons with the optional remote evaporator will have the evaporator shipped separately for field mounting and piping to the outdoor unit.

### Condenser Coils

Condenser coils are all aluminum alloy microchannel design with a series of flat tubes containing multiple, parallel flow microchannels layered between the refrigerant manifold piping. See “Condenser Coil Options and Coating Considerations” on page 15 for discussion of environmental factors related to material and coating options.

Figure 1: Microchannel Coil



Figure 2: Trailblazer® with Optional Full Louver Package

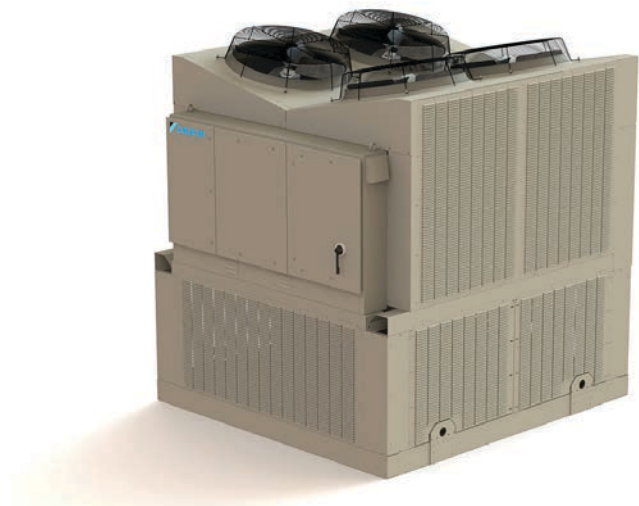



## Optional High Efficiency Variable Speed Condenser Fans

This option (available on 75-241 ton models) adds variable speed drives to the condenser fans on the chiller. The MicroTech® III controller will adjust the speed of the condenser fans using the VFD's to optimize chiller efficiency and maintain proper head pressure. This feature improves part load efficiency substantially and offers the ability to operate in low ambient conditions down to -10°F.

All High Efficiency Trailblazer® models with fully variable speed fans also include a sound reduction mode to allow for reduced-sound operation. Based on a user-settable time schedule, the chiller will enter the reduced noise mode, which will limit the speed of the condenser fans in order to reduce sound levels. This feature is especially helpful in areas that have more rigorous sound restrictions during certain times of day. While the lower fan speed may have a slight impact on the maximum unit capacity during hot outdoor conditions, the chiller can be set to automatically override the fan speed restrictions if additional capacity is needed. This way, the unit will always optimize between required capacity and the lowest sound level possible.

## Control System

The MicroTech® III advanced chiller controller surpasses all other microprocessor-based chiller control systems available today. This powerful, user-friendly control system provides the flexibility and performance needed for either stand-alone unit operation or the controller can be easily tied into the building automation system of choice using the Daikin Open Choices™ feature.

Open Choices™ allows one to choose from open standard protocols such as BACnet®, Modbus® and LONWORKS® to communicate easily with the building automation system that best meets the facility requirements. These optional communications modules are available factory installed or can be easily field installed.

The MicroTech® III controller's design will not only permit the chiller to run more efficiently, but will also simplify troubleshooting if a system failure occurs. Every MicroTech® III controller is programmed and tested prior to shipment to help provide a trouble-free start-up.

## Intelligent Equipment®

Intelligent Equipment (IE) from Daikin Applied is a secure, cloud-based controls solution that enables delivery equipment and/or system information to customers via web or mobile devices. A power measurement module and communications gateway installed on Daikin equipment enables the unit to be directly connected to the Internet via wireless (cellular, Wi-Fi) or local area network (LAN), providing management, monitoring control analysis and decision-making functionality for Daikin chiller systems and the facility.



## Features

- Remote monitoring and control of Daikin chillers
- Remote servicing capabilities
- Integration to the Energy Star® Portfolio Manager®
- Advanced data analytics including equipment performance, financial performance and building Comfort Index matrix based on ASHRAE Standard 55-2010
- Dynamic user dashboards with photo-realistic graphics and responsive-design interface optimized for users' mobile devices, tablets or PCs
- Secure, role-based user access

## Benefits

- Informed decision-making
- Increased equipment efficiency
- 24/7 monitoring capability
- Real-time equipment information
- Accelerated equipment payback
- Historical performance data
- Can be used with, or without, an existing building automation system (BAS)

Also see ASP 31-384 for more details.

## Optional Remote Interface Panel

In addition to the unit-mounted user interface provided with MicroTech® III controls, the Trailblazer® chillers can be individually equipped with a remote user interface. It provides convenient access to unit diagnostics and control adjustments without having to access a rooftop or outdoor location. One remote panel can be connected to up to eight chillers.

## Optional Pump Package

The on-board, integrated chilled water pump package provides important benefits:

- Simplifies the chilled water system design and installation
- Provides installation savings by reducing field piping, wiring and control costs
- Saves valuable floor space inside the building.
- Reduces project engineering content
- Greatly reduces pump operating costs with the optional variable flow pump VFD

Figure 3: Optional Pump Package Schematic

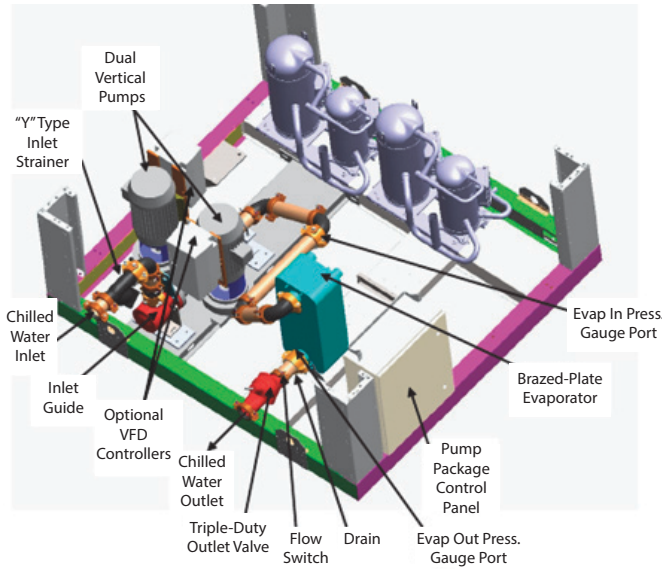

### Standard Components

**Single Pump:** Single spring inside seal, vertical, in-line, radially split-case pump, serviceable without breaking pipe connections. The motor and pump rotating assembly can be serviced without removing the pump casing from the line.

**Dual Pumps in a Single Casting:** Single spring inside-seal vertical, in-line, radially split-case pumps, mounted in a common casing with a common inlet connection and outlet connection and including a flapper valve to prevent recirculation when only one pump is operating. An isolation valve is included that allows one pump to operate when the other is removed. The pumps are designed for duty/standby, not parallel operation. All information and performance curves for the single pump arrangement (Model 4380) can be used for the dual pump arrangement (Model 4392).

The package is also equipped with:

- “Y” type inlet strainer
- combination triple-duty outlet valve containing:
  - discharge shutoff valve
  - check valve
  - flow throttling valve
- combination suction guide with flow stabilizing outlet vanes and stainless steel strainer with a disposable fine-mesh start-up strainer
- mounted and wired flow switch
- factory power and control wiring
- interconnecting piping and insulation of all cold surfaces

Various tank and connection options are available for field mounting. Refer to the schematic in Figure 3 for more information.

### Optional Variable Flow VFD

The operating cost savings resulting from using variable chilled water flow via a pump VFD is well known. In the past, however, its usage has been somewhat limited by the cost and uncertainty of field installing the required system pressure differential sensors.

Daikin Applied can now offer flow control through the pump VFD without the need for external pressure sensors. In addition to the sensorless operation, there are three other selectable operating modes:

**BAS Input:** The pump speed and system flow will be controlled from a customer-supplied BAS input signal.

**Remote Sensor Control:** The VFD is wired to a pressure sensor mounted in the chilled water piping system. This is the standard VFD control when a sensorless VFD is not used.

**Locally Selected Constant Speed Control:** Provides manual control of the pump speed, overriding any current automatic speed control.

Consult the current version of the installation manual for additional detailed information, which is available from your local Daikin Applied sales office or on [www.DaikinApplied.com](http://www.DaikinApplied.com).

### Optional Partial Heat Recovery

Partial heat recovery (available on 75-241 ton models) adds optional factory-installed heat exchangers and control logic to provide hot water for many uses such as dehumidification and pre-heating water for a boiler. This option reduces operating costs by using heat that already exists in the chiller instead of paying for another source of energy.

Figure 4: Partial Heat Recovery Heat Exchangers

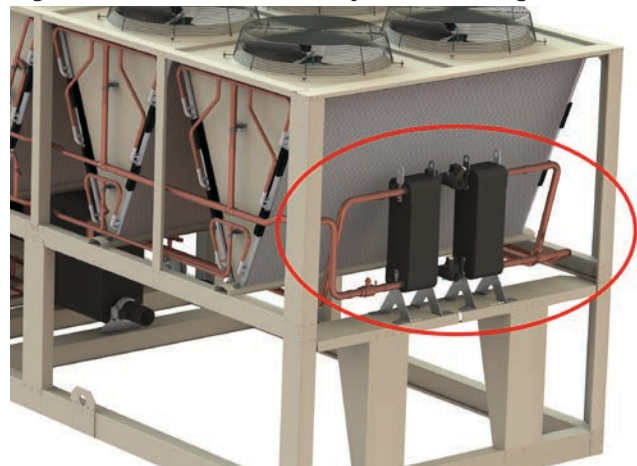

## Operating and Standby Limits

**Table 1: Operating Limits**

Maximum standby ambient temperature	130°F (54°C)
Maximum operating ambient temperature	105°F (41°C)
-with optional high ambient package (see "Partial Heat Recovery" on page 14)	125°F (52°C)
Minimum operating ambient temperature (standard control)	32°F (0°C)
-with optional low ambient control (see "High Ambient Operation" on page 13)	-10°F (-23°C)
Leaving chilled water temperature	40°F to 65°F (4°C to 18°C)
Leaving chilled fluid temperatures (with anti-freeze) - Note that in cases of high ambient temperature, the lowest leaving water temperature settings may be outside of the chiller operating envelope; consult Daikin Tools® to ensure chiller is capable of the required lift.	15°F to 65°F (-9°C to 18°C)
Operating chilled water delta-T range	6°F to 16°F (3.3°C to 8.9°C)
Maximum evaporator operating inlet fluid temperature	81°F (27°C)
Maximum evaporator non-operating inlet fluid temperature	100°F (38°C)

## Unit Placement

Trailblazer® units are for outdoor applications and can be mounted either on a roof or at ground level. For roof mounted applications, install the unit on a steel channel or I-beam frame to support the unit above the roof. For ground level applications, install the unit on a substantial base that will not settle. Use a one-piece concrete slab with footings extended below the frost line. Be sure the foundation is level within 0.5" (13 mm) over its length and width. The foundation must be strong enough to support the unit weight - see the Dimensions section starting on page 29.

## Service Clearance

### Sides

- **Models 30-70:** Minimum of 4 feet (1.2 meters)
- **Models 75-241:** It is highly recommended to provide a minimum of 8 feet (2.4 meters) on one side to allow for coil replacement. Coils can be removed from the top, allowing a minimum of 4 feet (1.2 meters) of side clearance; however, the unit performance may be derated.

### Control Panel End

- **All Models:** Minimum of 4 feet (1.2 meters)

### Opposite Control Panel End

- **Models 30-70:**  
Minimum of 7.5 feet (2.3 meters)
- **Models 75-241:** Minimum of 4 feet (1.2 meters)

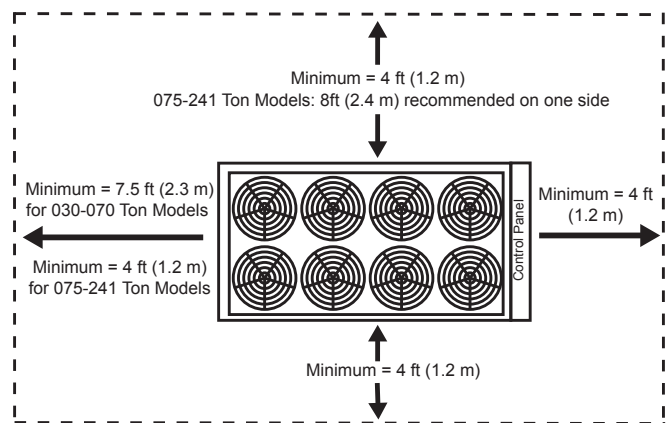
**Figure 5: Service Clearance**

## Operational Spacing Requirements

Sufficient clearance must be maintained between the unit and adjacent walls or other units to allow the required unit air flow to reach the coils. Failure to do so will result in a capacity reduction and an increase in power consumption. No obstructions are allowed above the unit at any height. The clearance requirements shown are a general guideline and cannot account for all scenarios. Such factors as prevailing winds, additional equipment within the space, design outdoor air temperature, and numerous other factors may require more clearance than what is shown. Additional clearances may be required under certain circumstances.

Graphs on the following pages give the minimum clearance for different types of installations and also capacity reduction and power increase if closer spacing is used. The graphs are based on individual cases and should not be combined with other scenarios.

**Case 1: Building or Wall on One Side of Unit**

**NOTE:** Assumes a solid height wall taller than unit. Refer to Case 4 for partial wall openings.

For models AGZ030-101E, maintain a 4 foot minimum from any solid height wall taller than unit.

For models AGZ110-130E, maintain a 6 foot minimum from any solid height wall taller than unit.

For models AGZ140-241E, maintain an 8 foot minimum clearance from any solid height wall taller than unit.

**Figure 6: Building or Wall on One Side of Unit**

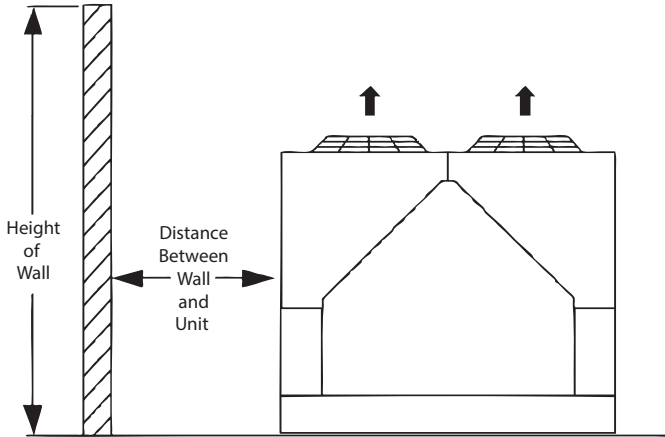

**Case 2: Two Units, Side-by-Side**

For models 030-180, there must be a minimum of 4 feet between two units placed side-by-side; however, performance may be affected at this distance. For models 191-241, the minimum is 6 feet as closer spacing may cause air recirculation and elevated condenser pressure. Assuming the requirement of one side having at least 8 feet of service clearance is met, Figure 8 below shows performance adjustments as the distance between two units increases.

**Figure 7: Two Units, Side-by-Side**

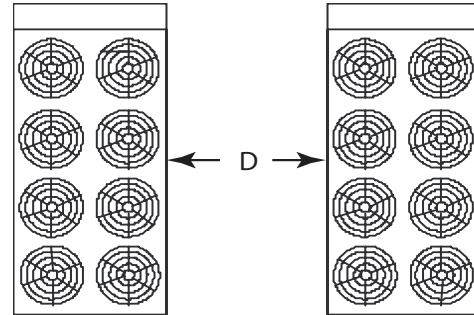

**Figure 8: Case 2 - Full Load Capacity Reduction**

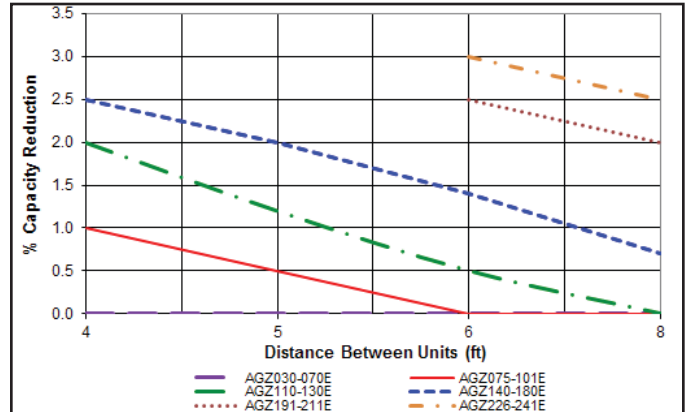

**Figure 9: Case 2 - Power Increase**

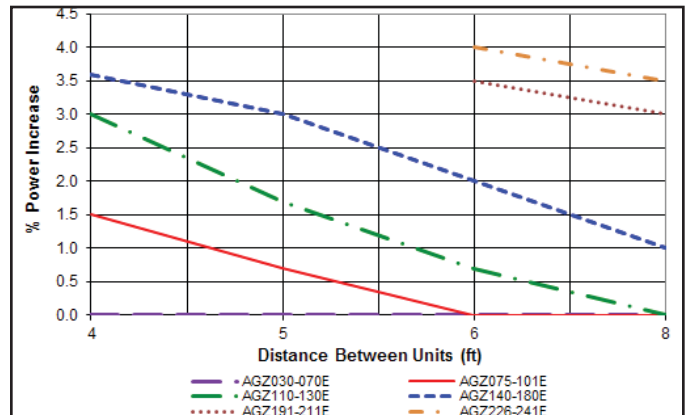



### Case 3: Three or More Units, Side-by-Side

For all models, there must be a minimum distance between any units placed side-by-side; however, performance may be affected at this distance. Minimum distances are: models 030 to 070 - 4 feet, models 075 to 101 - 5 feet, models 110 to 241 - 6 feet. Figure 11 and Figure 12 depict Case 3 performance adjustments as the distance between units increases.

**NOTE:** Data in Figure 11 and Figure 12 is for the middle unit with a unit on each side. See Case 2 adjustment factors for the two outside units.

Figure 10: Three or More Units, Side-by-Side

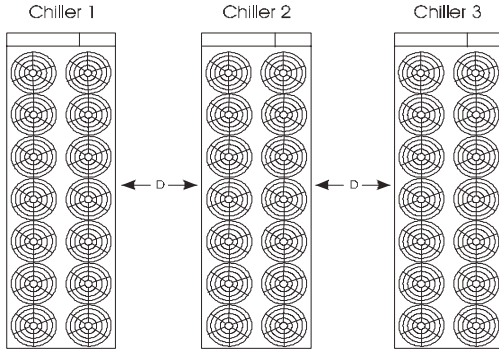

Figure 11: Case 3 - Full Load Capacity Reduction

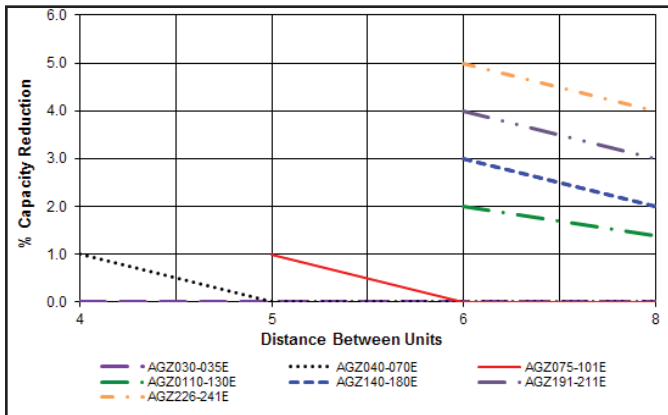
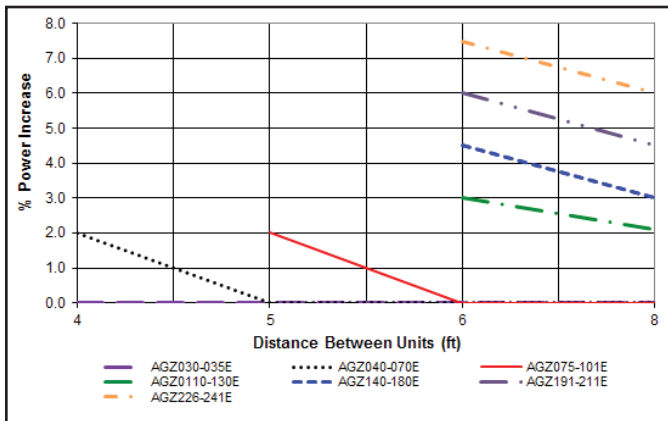

Figure 12: Case 3 - Power Increase



### Case 4: Open Screening Walls

Screening walls may be used to help conceal a unit. When possible, design these walls such that the combination of open area and distance from the unit (see Figure 13) does not require performance adjustment. If the wall opening percentage is less than recommended for the distance to the unit, it should be considered as a solid wall. It is assumed that the wall height is equal to or less than the unit height when mounted on its base support. If the wall height is greater than the unit height, see Case 5 for adjustment factors. The distance from the sides of the unit to the walls must be sufficient for service. For uneven wall spacing, the distance from the unit to each wall can be averaged providing no distance is less than 4 feet. Values are based on walls on all four sides.

Figure 13: Case 4 Allowable Wall Open Area

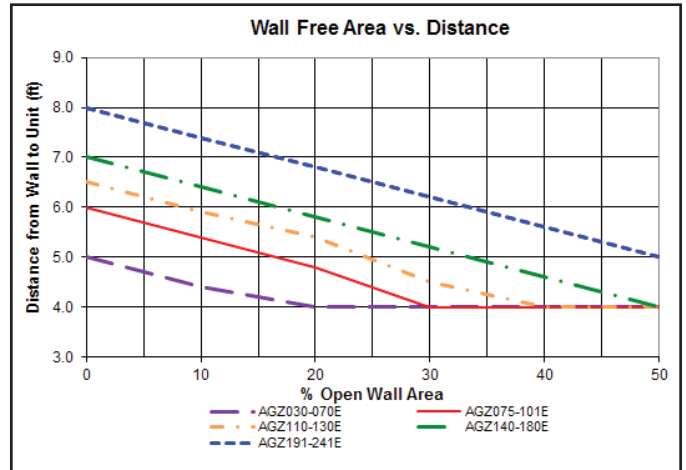



**Case 5: Pit Installation**

Pit installations can cause operating problems resulting from air recirculation and restriction and require care that sufficient air clearance is provided, safety requirements are met and service access is provided. A solid wall surrounding a unit is substantially a pit and this data should be used.

Steel grating is sometimes used to cover a pit to prevent accidental falls or trips into the pit. The grating material and installation design must be strong enough to prevent such accidents, yet provide abundant open area to avoid recirculation problems. Have any pit installation reviewed by your Daikin Applied sales representative prior to installation to ensure it has sufficient air-flow characteristics, and confirm it has been approved by the installation design engineer to avoid risk of accident. The following de-rates are based on single chiller installations only.

**Models AGZ030-070E:**

The Case 5 figures for models AGZ030-070E show adjustment factors for pit/wall heights of 4 feet, 5 feet, and 6 feet.

**Figure 14: Case 5 - Full Load Capacity Reduction (AGZ030E-070E)**

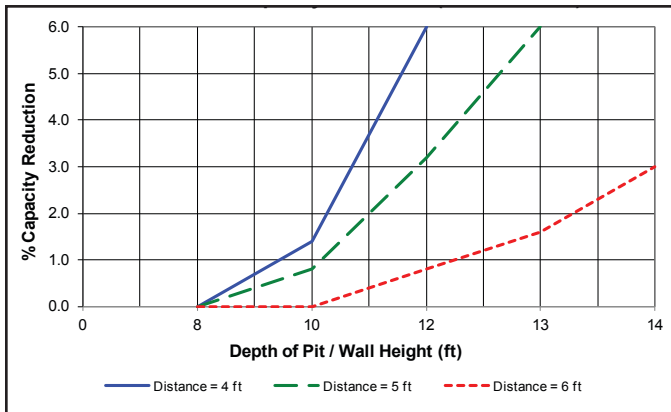

**Figure 15: Case 5 - Power Increase (AGZ030-070E)**

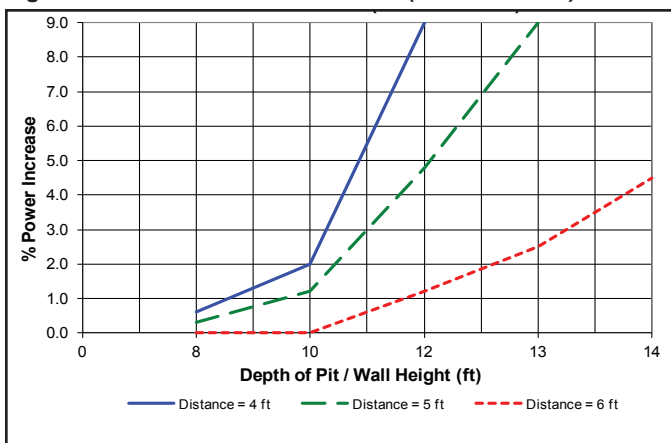

**Figure 16: Case 5 - Pit Installation**

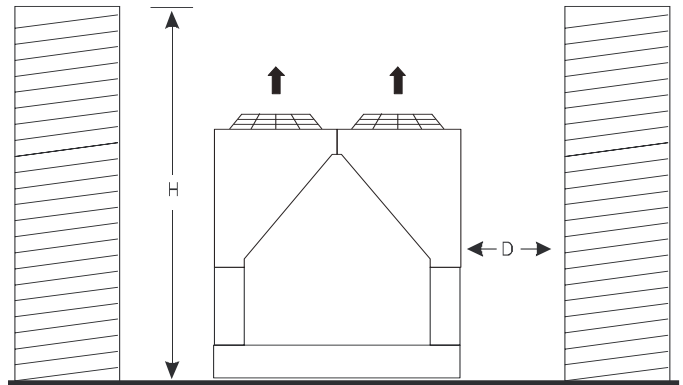

**Models AGZ075-130E:**

The Case 5 figures for models AGZ075-130E show adjustment factors for pit/wall heights of 5 feet, 6 feet, and 8 feet.

**Figure 17: Case 5 - Full Load Capacity Reduction (AGZ075-130E)**

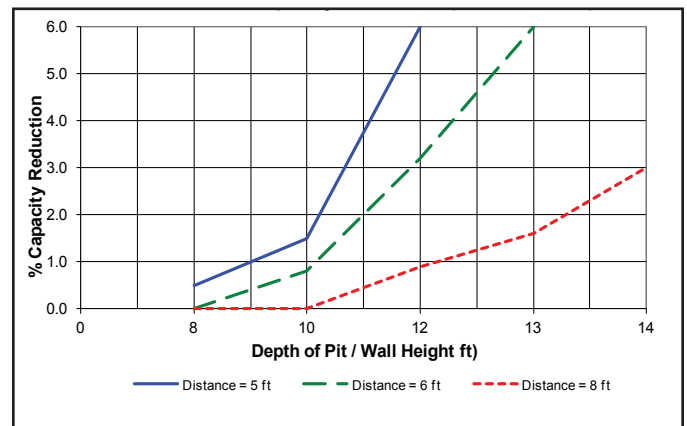

**Figure 18: Case 5 - Power Increase (AGZ075-130E)**

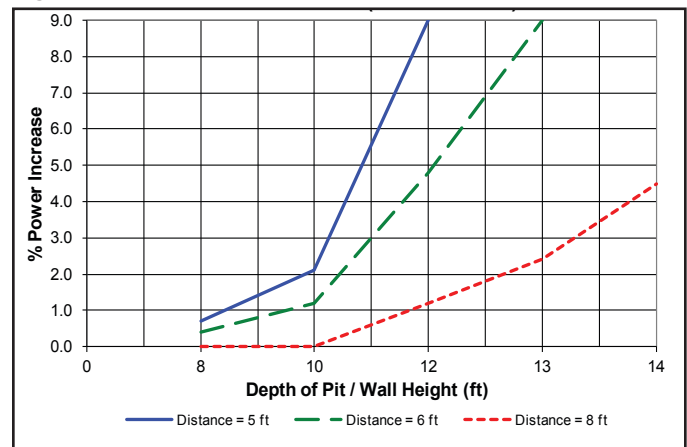

**Models AGZ140-241E:**

The Case 5 figures for models AGZ140-241E show adjustment factors for pit/wall heights of 6 feet, 8 feet, and 10 feet.

**Figure 19: Case 5 - Full Load Capacity Reduction (AGZ140-180E)**

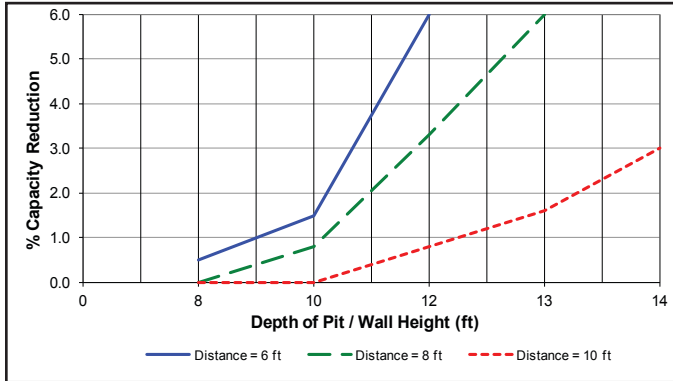

**Figure 20: Case 5 - Power Increase (AGZ140-211E)**

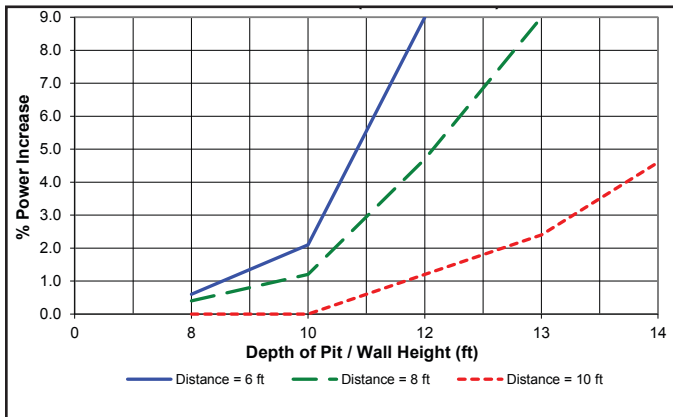

**Figure 21: Case 5 - Full Load Capacity Reduction (AGZ191-241E)**

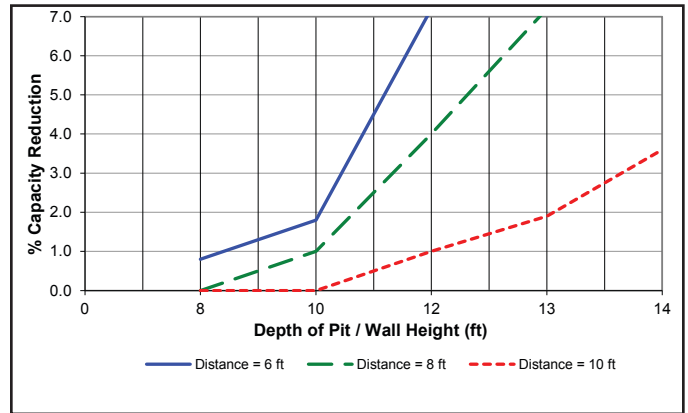

**Figure 22: Case 5 - Power Increase (AGZ226-241E)**

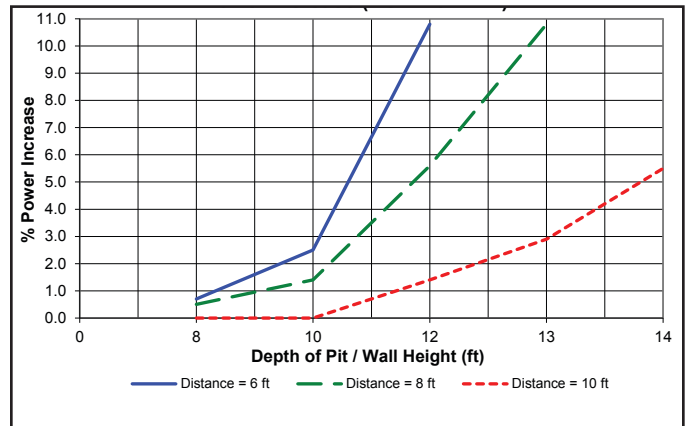

**Chilled Water Piping**

All evaporators and condensers have OGS-type grooved water connections (adhering to Standard AWWA C606) or optional flange connections. The installing contractor must provide matching mechanical connections. PVC piping should not be used. Be sure that water inlet and outlet connections match certified drawings and nozzle markings.

Field-installed water piping to the chiller **must** include:

- A cleanable strainer installed at the water inlet to the evaporator to remove debris and impurities before they reach the evaporator, causing damage. See the Inlet Strainer Guidelines and the current version of the product Installation, Operation and Maintenance manual on [www.DaikinApplied.com](http://www.DaikinApplied.com) for additional details.
- Adequate piping support to eliminate weight and strain on the fittings and connections.
- A water flow switch must be installed in the horizontal piping of the supply (evaporator outlet) water line to avoid evaporator freeze-up under low or no flow conditions. The flow switch may be ordered as a factory-installed option, a field-installed kit, or may be supplied and installed in the field. (See page 55 for more information.)

- Piping for units with brazed-plate evaporators must have a drain and vent connection provided in the bottom of the lower connection pipe and to the top of the upper connection pipe respectively, see Figure 23. These evaporators do not have drain or vent connections due to their construction.

It is **recommended** that the field-installed water piping to the chiller include:

- Thermometers at the inlet and outlet connections of the evaporator.
- Water pressure gauge connection taps and gauges at the inlet and outlet connections of the evaporator for measuring water pressure drop.
- Vibration eliminators in both the supply and return water lines. Pressure gauges must be installed in the inlet and outlet water lines to the evaporator.
- Insulated chilled water piping to reduce heat loss and prevent condensation. For information on freeze protection, see “Evaporator Freeze Protection” on page 13.

Figure 23: Typical Piping, Brazed-Plate Evaporator

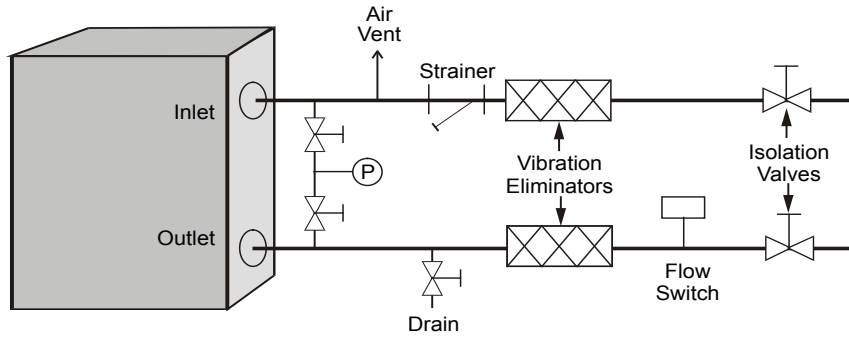

WELDED PIPE CONNECTIONS ARE NOT ALLOWED BETWEEN THE STRAINER AND EVAPORATOR DUE TO THE CHANCE OF SLAG ENTERING THE EVAPORATOR

### Inlet Strainer Guidelines

An inlet water strainer kit **must** be installed in the chilled water piping before the evaporator inlet. Several paths are available to meet this requirement:

1. A factory installed option.
2. A field-installed kit shipped-loose with the unit that consists of:
  - Y-type area strainer with 304 stainless steel perforated basket, Victaulic pipe connections and strainer cap.
  - Extension pipe with two Schrader fittings that can be used for a pressure gauge and thermal dispersion flow switch. The pipe provides sufficient clearance from the evaporator for strainer basket removal.
  - 0.5-inch blowdown valve
  - Two grooved clamps

Both are sized per Table 2 and with the pressure drop shown in the Strainer Pressure Drop graph. Connection sizes are given in the physical data section beginning on page 25.

3. A field-supplied strainer that meets specification and installation requirements of the current Installation, Operation and Maintenance Manual available at [www.DaikinApplied.com](http://www.DaikinApplied.com).

Table 2: Strainer Data

Trailblazer™ Model	Strainer Size in (mm)	Maximum perforation size in (mm)	Factory Installed Option	Field Installed Option
030-070	2.5 (64)	0.063 (1.6)	Y	Y
075-130	3.0 (76)	0.063 (1.6)	Y	Y
140-180	4.0 (102)	0.063 (1.6)	Y	Y
191-241	6.0 (152)	0.063 (1.6)	Y	Y

Figure 25: Factory Installed Strainer

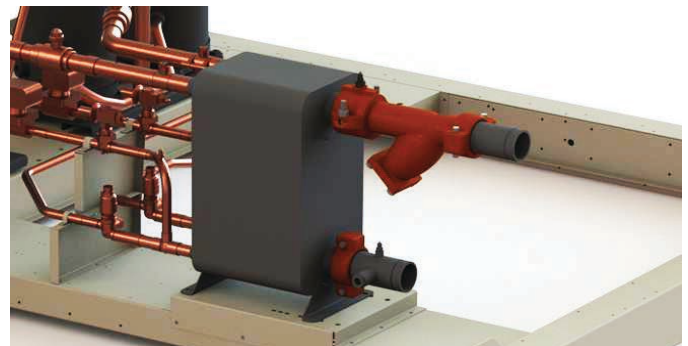
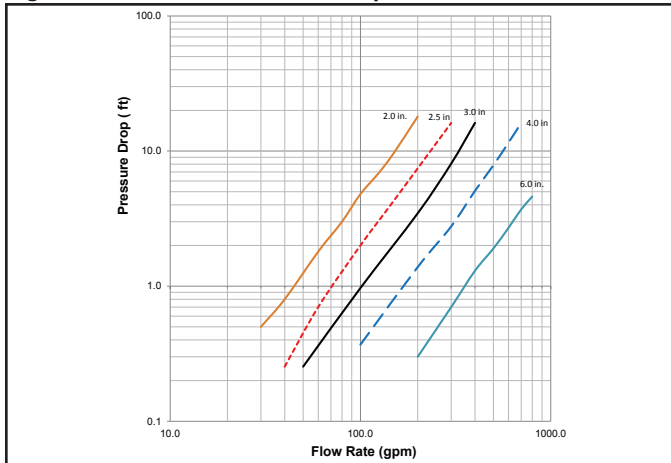

Figure 24: Strainer Pressure Drop



### Water Flow Limitations

#### Constant Flow

The evaporator flow rates and pressure drops shown in Figure 30 on page 22 and Table 14 on page 23 are for full load design purposes. The maximum flow rate and pressure drop is based on a 6°F temperature drop. Flow rates above the maximum values will result in unacceptable temperature and pressure drops and can cause excessive erosion, potentially leading to failure.

The minimum flow and pressure drop is based on a full load evaporator temperature drop of 16°F. Evaporator flow rates below the minimum values can result in laminar flow causing freeze-up problems, scaling and poor control.

#### Variable Flow

Reducing evaporator flow in proportion to load can reduce system power consumption. The rate of flow change should be

a maximum of 10 percent of the flow per minute. For example, if the maximum design flow is 200 gpm and it will be reduced to a flow of 140 gpm, the change in flow is 60 gpm. Ten percent of 200 gpm equals 20 gpm change per minute, or a minimum of three minutes to go from maximum to desired flow. The water flow through the evaporator must remain between the minimum and maximum values listed in Table 14 on page 23. If flow drops below the minimum allowable, large reductions in heat transfer can occur. If the flow exceeds the maximum rate, excessive pressure drop and tube erosion can occur.

## System Water Volume Considerations

All chilled water systems need adequate time to recognize a load change, respond to the change and stabilize to avoid undesirable short cycling of the compressors or loss of temperature control. In air conditioning systems, the potential for short cycling usually exists when the building load falls below the minimum chiller plant capacity or on close-coupled systems with very small water volumes. Some of the things the designer should consider when looking at water volume are the minimum cooling load, the minimum chiller plant capacity during the low load period and the desired cycle time for the compressors. Assuming that there are no sudden load changes and that the chiller plant has reasonable turndown, a rule of thumb of “gallons of water volume equal to two to three times the chilled water gpm flow rate” is often used. A storage tank may have to be added to the system to reach the recommended system volume.

## Evaporator Freeze Protection

Evaporator freeze-up can be a concern in the application of air-cooled water chillers in areas experiencing below freezing temperatures. To protect against freeze-up, insulation and an electric heater are furnished with the evaporator. AGZ-E chillers have an external plate heater and thermostat that helps protect the evaporator down to -20°F (-29°C) ambient air temperature. Although the evaporator is equipped with freeze protection, it does not protect water piping external to the unit or the evaporator itself if there is a power failure or heater burnout, or if the chiller does not directly control the chilled water pumps. Use one of the following recommendations for additional protection:

1. If the unit will not be operated during the winter, drain evaporator and chilled water piping and flush with glycol.
2. Add a year-round glycol solution to the chilled water system to provide freeze protection. Freeze point should be approximately 10°F (5.6°C) below minimum design ambient temperature or 10°F below the lowest design leaving water temperature, whichever is lower. The use of glycol anti-freeze is generally considered the safest protection against freeze-up, however, it will reduce the performance of the unit, depending the concentration. Take this into consideration during initial system design and selection. On glycol applications, a minimum fluid concentration should be based on Burst Protection limits.
3. The field installation of thermostatically controlled heat tracing and insulation to exposed piping. Factory insulation will have to be removed and replaced after installation of the tracing.

4. Continuous circulation of water through the chilled water piping and evaporator. (Dependent on power availability).

The evaporator heater cable or immersion heater is factory wired to the 115 volt circuit in the control box. This power should be supplied from a separate source to maximize unit protection, but it can be supplied from the control circuit. Operation of the heaters is automatic through the ambient sensing thermostat that energizes the evaporator heaters for protection against freezing. Unless the evaporator is drained in the winter or contains an adequate concentration of anti-freeze, the disconnect switch to the evaporator heater must be closed. Conversely, do not apply heat to the evaporator if it is drained.

## Chilled Water Pump

It is important that the chilled water pumps be wired to, and controlled by, the chiller’s microprocessor. The chiller controller has the capability to selectively send the signal to a pump relay (by others) to start pump A or B or automatically alternate pump selection and also has standby operation capability. The controller will energize the pump whenever at least one circuit on the chiller is enabled to run, whether there is a call for cooling or not. This helps ensure proper unit start-up sequence. The pump will also be turned on when the water temperature remains equal to or goes below the Freeze Setpoint for longer than a specified time to help prevent evaporator freeze-up. Connection points are shown in the Field Wiring Diagram on page 45 and page 46.

### CAUTION

Adding glycol or draining the system is the recommended method of freeze protection. If the chiller does not have the ability to control the pumps and the water system is not drained in temperatures below freezing, catastrophic evaporator failure may occur.

Failure to allow pump control by the chiller may cause the following problems:

1. If any device other than the chiller attempts to start the chiller without first starting the pump, the chiller will lock out on the No Flow alarm and require manual reset.
2. If the chiller evaporator water temperature drops below the “Freeze setpoint” the chiller will attempt to start the water pumps to avoid evaporator freeze. If the chiller does not have the ability to start the pumps, the chiller will alarm due to lack of water flow.
3. If the chiller does not have the ability to control the pumps and the water system is not drained in temperatures below freezing, the chiller may be subject to catastrophic evaporator failure due to freezing. The freeze rating of the evaporator is based on the immersion heater and pump operation. The immersion heater itself may not be able to properly protect the evaporator from freezing without circulation of water.

## High Ambient Operation

Trailblazer® units for high ambient operation (105°F to 125°F, 40°C to 52°C) require the addition of the optional high ambient package that includes a small fan with a filter in the air intake to cool the control panel. All units with the optional VFD low ambient fan control include the high ambient option.

## Low Ambient Operation

Compressor staging is adaptively determined by system load, ambient air temperature, and other inputs to the MicroTech® III control. The standard minimum ambient temperature is 32°F (0°C). A low ambient option with fan VFD allows operation down to -10°F (-23°C). The minimum ambient temperature is based on still conditions where the wind is not greater than 5 mph. Greater wind velocities will result in reduced discharge pressure, increasing the minimum operating ambient temperature. Field-installed louvers are available and recommended to help allow the chiller to operate effectively down to the ambient temperature for which it was designed.

## Partial Heat Recovery

Partial heat recovery for Trailblazer® chillers is achieved by adding an auxiliary heat exchanger in each unit refrigerant circuit between the compressors and the condenser coils. The heat exchangers transfer the heat from the compressor discharge gas to a separate water loop which can be used for various heating applications. The heating recovery cycle is only available when the chiller is running. The partial heat recovery auxiliary heat exchanger can return water up to 155°F; however, this value cannot be set. The amount of heat produced can be up to 50% of the nominal cooling capacity and is dependent on the requested cooling load, the operating temperatures, and the water flow rate through the auxiliary heat exchangers. Please note, if potable water is desired, a secondary heat exchanger in a separate water loop must be used. Contact your local Daikin Applied for information on specific applications.

Partial heat recovery components that are factory-supplied:

- Brazed plate heat exchangers - one in each circuit with the water piped together in parallel for one inlet and one

outlet water connection, see Figure 31 for pressure drops.

- Insulation of heat exchangers and water piping at the unit.
- Separate temperature sensors for inlet and outlet water piping at the heat exchangers.
- Connections for air vent at the outlet water piping and drain at the inlet water piping.
- Immersion heater for each auxiliary heat exchanger for freeze protection.

**Required** partial heat recovery field piping (see Figure 26) and connections (see page 47) are listed below.

- An external 3-way valve or a variable speed pump in the auxiliary heat exchanger water piping for modulation of flow through the heat exchangers by the unit controller. Heat recovery water loop pump must also be controlled by the chiller controller.
- A cleanable strainer with perforations no larger than 0.063" (1.6 mm) diameter must be installed within 5 feet (1500 mm) of pipe length from the heat exchanger inlet and downstream of any welded connections, see Figure 24 for pressure drop.
- Water piping and other portions of the heat recovery water loop must be insulated to prevent heat loss and possible injury due to hot surfaces.
- A field-installed safety or relief valve on the water side is required to prevent risks in case the water temperature thermostat should fail.
- Separate 120 volt power supply for immersion heaters. A junction box for a 120 Volt power connection is provided.
- A water tank and an additional water heater is suggested in the heat recovery piping loop for initial water temperature control and better loop stability. Typical loop sizing guidance is water volume (in gallons) be greater than or equal to two to three times the heat recovery water flow rate (in gallons/minute).

**Figure 26: Partial Heat Recovery Field Piping Schematic**

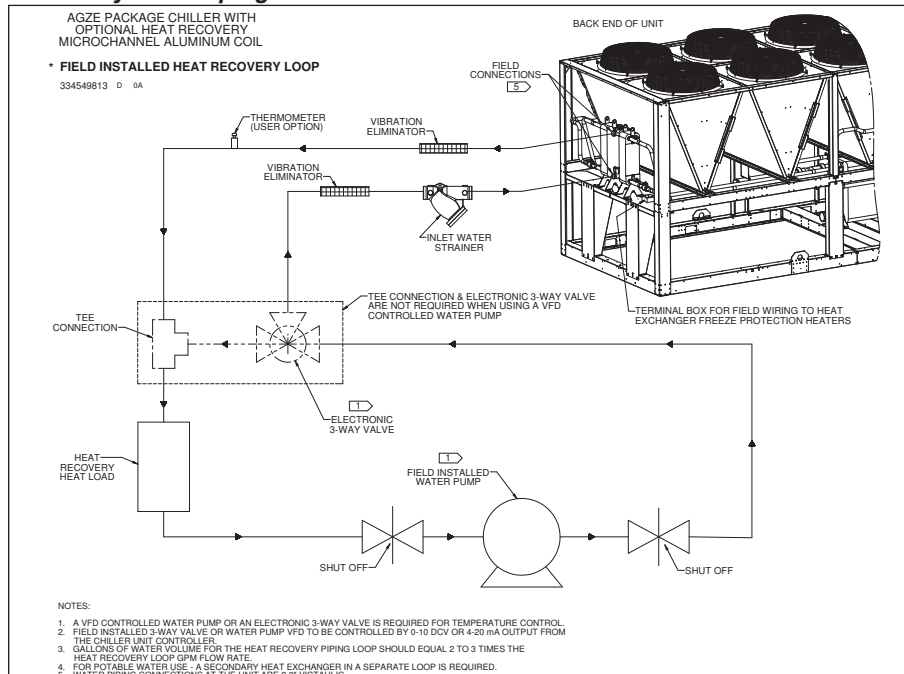



## Condenser Coil Options and Coating Considerations

The standard coils on the Trailblazer® chiller are an all aluminum alloy microchannel design with a series of flat tubes containing multiple, parallel flow microchannels layered between the refrigerant manifolds. The microchannel coils are designed to withstand 1000+ hour acidified synthetic sea water fog (SWAAT) test (ASTM G85-02) at 120°F (49°C) with 0% fin loss and develop no leaks. The all-aluminum microchannel coils provide superior longevity and durability for non-corrosive applications.

**Table 3: Coil/Coating Selection Matrix**

Coil Option	Non-Corrosive <sup>1</sup>	Unpolluted Marine <sup>2</sup>	Industrial <sup>3</sup>	Combined Marine-Industrial <sup>4</sup>
Standard Microchannel	+++	-	-	-
Epoxy-coated	+++	+++	+++	++

**NOTE:**

1. Non-corrosive environments may be estimated by the appearance of existing equipment in the immediate area where the chiller is to be placed.
2. Marine environments should take into consideration proximity to the shore as well as prevailing wind direction.
3. Industrial contaminants may be general or localized, based on the immediate source of contamination (i.e. diesel fumes due to proximity to a loading dock).
4. Combined marine-industrial are influenced by proximity to shore, prevailing winds, general and local sources of contamination.

**Epoxy coil coating** is a water-based extremely flexible and durable epoxy polymer coating uniformly applied to all coil surfaces through a multi-step, submerged electrostatic coating process. Epoxy-coated condenser coils provide a 6000+ hour salt spray resistance per ASTM B117-90, applied to both the coil and the coil frames. The epoxy-coated coils also receive a UV-resistant urethane top-coat to provide superior resistance to degradation from direct sunlight. This coil coating option provides the best overall protection against corrosive marine, industrial or combined atmospheric contamination. This coating option may be applied to any of the untreated coil options offered, to provide excellent longevity and resistance to corrosion.

**Figure 27: Epoxy Coil Coating**

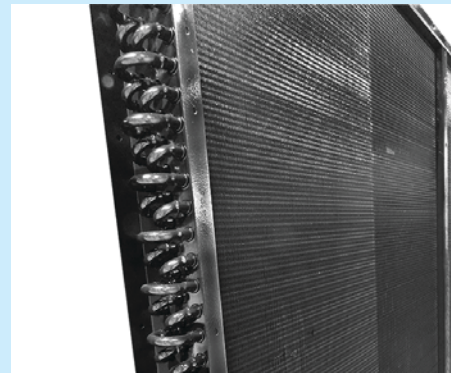

## Background Information

Sound levels can be as important as unit cost and efficiency. The inherently quiet scroll compressors used in Trailblazer® chillers are coupled with precision engineering for industry-leading sound levels.

AHRI has established standards to provide uniform methods for the determination of the sound levels of equipment. For large air-cooled chillers, it is AHRI Standard 370, “Sound Ratings of Large Outdoor Refrigeration and Air-Conditioning Equipment.” Data contained in this section are in accordance with this standard.

## “A” Weighting

Sound values may be represented several ways. One of the more common forms is the “A” weighted value, which adds or subtracts a specific amount to each center band frequency, then logarithmically adds the values to establish a single value. The “A” scale is used to represent how the human ear receives sound. The amount added in each frequency band directly corresponds to how sensitive the human ear is to each frequency.

**Table 4: “A” Scale Relative Response to Human Ear**

dB(A)	Frequency, f, in Hz									
	31.5	63	125	250	500	1K	2K	4K	8K	16K
	-39.4	-26.2	-16.1	-8.6	-3.2	0	+1.2	+1.0	-1.1	-6.6

## Sound Pressure Levels - Full Load

Sound pressure is the sound level that can be measured at some distance from the source. Sound pressure varies with distance from the source and depends on the surroundings. For example, a brick wall (a reflective surface) located 10 feet from a unit will affect the sound pressure measurements differently than a brick wall at 20 feet. Sound pressure is measured in decibels (dB).

All sound pressure data in the following pages are considered typical of what can be measured in a free field with a handheld sound meter, in the absence of any nearby reflective surfaces except the floor under the unit. Sound pressure levels are measured at 30 feet (10 meters) from the side of the unit at 100% load and standard AHRI conditions (per AHRI standard 550/590) of 95°F (35°C) ambient air temperature and 44°F (7°C) leaving evaporator water temperatures for air-cooled units.

## Sound Power Levels

Sound power is a calculated quantity and cannot be measured directly like sound pressure. Sound power is not dependent on the surrounding environment or distance from the source, as is sound pressure. It can be thought of as basic sound level emanating from the unit without consideration of distance or obstructions. Measurements are taken over a prescribed area around the unit and the data is mathematically calculated to give the sound power, dB. Acoustical consultants sometimes use sound power octave band data to perform a detailed acoustical analysis.

**Figure 28: Sound Power vs. Sound Pressure**

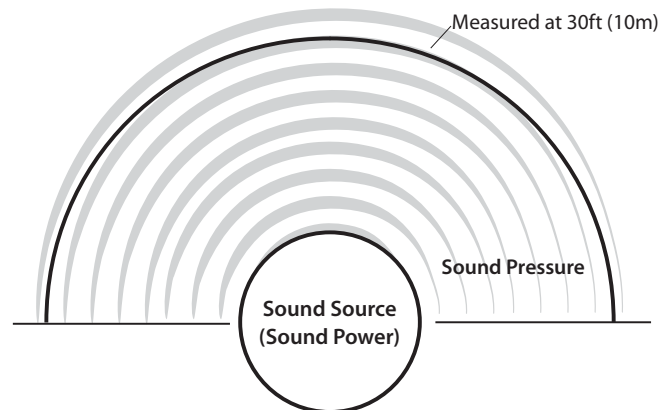

The data in Table 6 on page 18 and Table 10 on page 20 present sound power levels per AHRI Standard 370, “Sound Rating of Large Outdoor Refrigerating and Air Conditioning Equipment”. This standard was developed to establish uniform methods of determining the sound power radiated by large outdoor equipment. Measurements are taken over a prescribed area around the unit and the data is mathematically calculated to give the sound power, dB.

## Sound Reduction due to Distance from the Unit

The distance between a source of sound and the location of the sound measurement plays an important role in minimizing sound problems. Sound pressure can be calculated at any distance from the unit if sound power and “Q,” the directionality factor, are known. “Q” is a dimensionless number that compensates for the type of sound reflection from the source. For example, a unit sitting on a flat roof or ground with no other reflective surfaces or attenuation due to grass, snow, etc., between source and receiver will have Q=2. See Figure 29 for definitions of Q=1, Q=2, and Q=4.

Figure 29: “Q” Reflective Sources Illustration

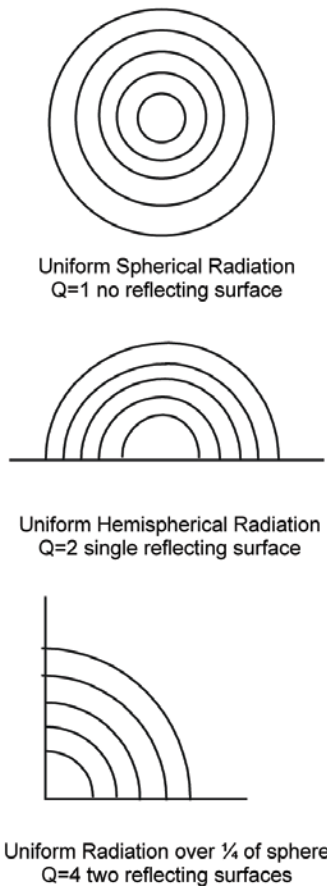

Once sound power and “Q” are known, sound pressure at any distance from the unit can be calculated using the following equation:

$$L_p = L_w - (20 \log r) + (10 \log Q) - 0.5$$

Where:

- L<sub>p</sub> = sound pressure
- L<sub>w</sub> = sound power
- r = distance from unit in feet
- Q = directivity factor

With Q=1, Unit suspended in space (theoretical condition), the equation simplifies to:

$$L_p = L_w - (20 \log r) - 0.5$$

With Q=2, for a unit sitting on a flat roof or ground with no adjacent vertical wall as a reflective surface, the equation simplifies to:

$$L_p = L_w - (20 \log r) + 2.5$$

With Q=4 for a unit sitting on a flat roof or ground with one adjacent vertical wall as a reflective surface, the equation simplifies to:

$$L_p = L_w - (20 \log r) + 5.5$$

Results for typical distances and the two most usual cases of “Q” are tabulated in Table 5.

Table 5: dB Conversion of Sound Power to Pressure

Distance from Sound Source ft (m)	DB Reduction from Sound Power at the Source to Sound Pressure at Referenced Distance	
	Q=2	Q=4
30 (9)	27.1	24.0
50 (15)	31.6	28.5
75 (23)	35.1	32.0
100 (30)	37.6	34.5
150 (46)	41.1	38.0
200 (61)	43.6	40.5
300 (91)	47.6	44.0

### Sound Data Notes

When referencing sound data below, please note:

1. Octave band readings are flat dB, overall is A-weighted.
2. Sound pressure data taken at 30 feet (9 meters) from side of unit.
3. Q=2, unit on flat surface with no adjacent wall.

All High Efficiency Trailblazer® models with fully variable speed fans also include a sound reduction mode to allow for reduced-sound operation. Based on a user-settable time schedule, the chiller will enter the reduced noise mode, which will limit the speed of the condenser fans in order to reduce sound levels. This feature is especially helpful in areas that have more stringent sound restrictions during certain times of day. While the lower fan speed may have a slight impact on the maximum unit capacity during hot outdoor conditions, the chiller can be set to automatically override the fan speed restrictions if additional capacity is needed. This way, the unit will always optimize between required capacity and the lowest sound level possible.

**Table 6: 60 Hz Sound Power without Sound Insulation**

Model	Octave Band at Center Frequency								Overall A-Weighted			
	63	125	250	500	1000	2000	4000	8000	Without Sound Insulation	75% Load	50% Load	25% Load
30	92	91	88	87	83	78	73	68	88	87	85	84
35	92	91	89	87	83	78	73	68	88	87	85	84
40	92	91	90	88	84	79	74	69	89	88	86	85
45	93	92	91	89	85	79	74	69	90	89	87	86
50	93	93	91	89	85	79	74	69	90	89	87	86
55	93	93	93	89	86	81	76	71	91	90	88	87
60	94	93	94	89	86	81	76	71	91	90	88	87
65	95	94	94	89	87	81	76	71	92	91	89	88
70	95	95	94	89	87	81	76	71	92	91	90	89
75/76	95	95	95	89	87	81	76	71	92	91	89	88
80/81	95	95	95	89	87	81	76	71	92	91	89	88
90/91	94	95	92	91	89	83	81	81	93	92	90	89
100/101	93	95	92	92	89	83	82	82	94	93	91	90
110	93	96	92	92	90	84	84	82	95	94	92	91
120	93	96	92	92	90	84	84	82	95	94	92	91
130	94	97	93	93	91	85	85	84	96	95	93	92
140	95	98	93	94	93	87	86	85	97	96	94	93
150	96	98	95	94	95	90	88	85	99	98	96	95
161	97	98	96	95	95	91	90	86	99	98	96	95
170	96	98	96	94	91	88	88	85	97	96	94	93
180	96	98	96	94	91	88	88	85	97	96	94	93
191	96	98	96	94	91	88	88	85	97	96	94	93
211	97	98	97	94	94	90	89	85	99	98	96	95
226	98	98	98	94	94	90	90	86	99	98	96	95
241	98	98	98	95	96	90	90	86	100	99	97	96

**Table 7: 60 Hz Sound Power with Sound Insulation**

Model	Octave Band at Center Frequency								Overall A-Weighted			
	63	125	250	500	1000	2000	4000	8000	With Sound Insulation	75% Load	50% Load	25% Load
30	84	84	83	84	77	75	74	70	85	84	82	81
35	84	84	83	84	77	75	74	70	85	84	82	81
40	84	84	83	84	77	75	74	70	85	84	82	81
45	85	85	85	86	80	77	75	70	87	86	84	83
50	85	85	85	86	80	77	75	70	87	86	84	83
55	85	85	85	86	80	77	75	70	87	86	84	83
60	85	85	85	86	80	77	75	70	87	86	84	83
65	86	85	85	86	80	77	75	70	87	86	84	83
70	88	85	85	86	80	77	75	70	87	86	85	84
75/76	88	85	86	86	81	81	77	70	88	87	85	84
80/81	88	85	87	86	83	81	77	71	88	88	86	85
90/91	88	87	87	86	83	80	77	71	88	87	85	84
100/101	90	86	86	86	83	80	78	71	88	87	85	84
110	90	86	87	86	82	79	76	71	88	87	85	84
120	91	85	88	86	82	81	79	72	89	88	86	85
130	91	85	88	86	82	81	80	72	89	88	86	85
140	91	86	90	87	82	81	80	72	89	88	86	85
150	92	87	91	87	84	84	82	72	90	90	88	87
161	93	87	91	87	85	84	82	72	91	90	88	87
170	92	88	89	89	86	82	80	74	91	90	88	87
180	92	88	89	89	86	82	80	74	91	90	88	87
191	92	88	89	89	86	82	80	74	91	90	88	87
211	93	88	90	89	89	84	81	74	93	92	90	89
226	94	88	91	89	89	84	82	75	93	92	90	89
241	94	88	91	90	91	84	82	75	94	93	91	90

**Table 8: 60 Hz Sound Pressure (at 30 feet from side of unit) without Sound Insulation**

Model	Octave Band at Center Frequency, 30 ft. from unit								Overall A-Weighted			
	63	125	250	500	1000	2000	4000	8000	Without Sound Insulation	75% Load	50% Load	25% Load
30	65	64	61	60	56	51	46	41	61	60	58	57
35	65	64	62	60	56	51	46	41	61	60	58	57
40	65	64	63	61	57	52	47	42	62	61	59	58
45	66	65	64	62	58	52	47	42	63	62	60	59
50	66	66	64	62	58	52	47	42	63	62	60	59
55	66	66	66	62	59	54	49	44	64	63	61	60
60	67	66	67	62	59	54	49	44	64	63	61	60
65	68	67	67	62	60	54	49	44	65	64	62	61
70	68	68	67	62	60	54	49	44	65	64	63	62
75/76	68	68	68	62	60	54	49	44	65	64	62	61
80/81	66	63	63	63	62	56	53	53	66	65	63	62
90/91	67	67	67	64	62	56	54	54	67	66	64	63
100/101	66	68	65	65	62	56	57	55	67	66	64	63
110	66	69	67	65	61	55	55	55	67	66	64	63
120	68	67	67	65	61	59	60	57	68	67	65	64
130	67	68	68	64	61	60	60	55	68	67	65	64
140	68	69	69	65	61	60	61	56	69	68	66	65
150	69	70	70	65	62	62	62	56	70	69	67	66
161	69	70	70	65	62	63	62	56	70	69	67	66
170	69	71	69	67	64	61	60	58	70	69	67	66
180	69	71	69	67	64	61	61	58	70	69	67	66
191	69	71	69	67	64	61	61	58	70	69	67	66
211	70	71	70	67	66	62	62	58	71	70	68	67
226	70	71	70	67	66	62	62	59	71	70	68	67
241	70	71	70	68	68	62	62	59	72	71	69	68

**Table 9: 60 Hz Sound Pressure (at 30 ft from side of unit) with Sound Insulation**

Model	Octave Band at Center Frequency, 30 ft. from unit								Overall A-Weighted			
	63	125	250	500	1000	2000	4000	8000	With Sound Insulation	75% Load	50% Load	25% Load
30	57	57	56	57	50	48	47	43	58	57	55	54
35	57	57	56	57	50	48	47	43	58	57	55	54
40	57	57	56	57	50	48	47	43	58	57	55	54
45	58	58	58	59	53	50	48	43	60	59	57	56
50	58	58	58	59	53	50	48	43	60	59	57	56
55	58	58	58	59	53	50	48	43	60	59	57	56
60	58	58	58	59	53	50	48	43	60	59	57	56
65	59	58	58	59	53	50	48	43	60	59	57	56
70	61	58	58	59	53	50	48	43	60	59	58	57
75/76	61	58	59	59	54	54	50	43	61	60	58	57
80/81	61	59	59	59	55	54	50	44	61	60	58	57
90/91	61	60	60	59	56	53	50	44	61	60	58	57
100/101	63	59	59	59	56	53	51	44	61	60	58	57
110	63	59	60	59	55	52	49	44	61	60	58	57
120	64	58	61	59	55	54	51	45	61	61	59	58
130	63	58	61	59	56	54	51	45	62	61	59	58
140	64	59	62	60	56	54	53	45	63	62	60	59
150	65	60	63	60	57	56	54	45	63	63	61	60
161	65	60	63	60	58	56	54	45	64	63	61	60
170	65	61	62	62	59	55	53	47	64	63	61	60
180	65	61	62	62	60	56	54	47	64	63	61	60
191	65	61	62	62	60	56	54	47	64	63	61	60
211	66	61	63	62	62	57	55	47	66	65	63	62
226	66	61	63	62	62	57	55	48	66	65	63	62
241	66	61	63	63	63	57	55	48	67	66	64	63



**Table 10: 50 Hz Sound Power**

Model	Octave Band at Center Frequency								Overall A-Weighted			
	63	125	250	500	1000	2000	4000	8000	Without Sound Insulation	75% Load	50% Load	25% Load
30	89	88	85	84	80	75	70	65	85	84	82	81
35	89	88	85	84	80	75	70	65	85	84	82	81
40	89	88	86	84	80	75	70	65	85	84	82	81
45	89	88	87	85	81	76	71	66	86	85	83	82
50	90	89	88	86	82	76	71	66	87	86	84	83
55	90	90	88	86	82	76	71	66	87	86	84	83
60	90	90	90	86	83	78	73	68	88	87	85	84
65	91	90	91	86	83	78	73	68	88	87	85	84
70	92	91	91	86	84	78	73	68	89	88	87	86
75/76	92	92	91	86	84	78	73	68	89	89	86	85
80/81	92	92	91	86	84	78	73	68	89	89	86	85
90/91	91	92	88	88	86	80	78	78	90	90	87	86
100/101	90	92	88	89	86	80	79	79	91	91	88	87
110	90	93	88	89	87	81	81	79	91	91	88	87
120	90	93	88	89	87	81	81	79	91	91	88	87
130	91	94	89	90	88	82	82	80	92	92	89	88
140	92	95	89	91	90	84	83	81	94	94	91	90
150	93	95	91	91	92	87	85	81	95	95	92	91
161	94	95	92	92	92	88	86	82	95	95	92	91
170	93	95	93	90	87	84	84	82	94	94	91	90
180	93	95	93	91	88	85	84	82	94	94	91	90
191	93	95	93	91	88	85	85	82	94	94	91	90
211	94	95	93	91	91	87	85	81	95	95	92	91
226	95	95	94	91	91	87	86	82	95	95	92	91
241	95	95	94	92	93	87	86	82	96	96	93	92

**Table 11: 50 Hz Sound Power with Sound Insulation**

Model	Octave Band at Center Frequency								Overall A-Weighted			
	63	125	250	500	1000	2000	4000	8000	With Sound Insulation	75% Load	50% Load	25% Load
30	81	81	80	81	74	72	71	67	82	81	79	78
35	81	81	80	81	74	72	71	67	82	81	79	78
40	81	81	80	81	74	72	71	67	82	81	79	78
45	82	82	82	83	77	74	72	67	84	83	81	80
50	82	82	82	83	77	74	72	67	84	83	81	80
55	82	82	82	83	77	74	72	67	84	83	81	80
60	82	82	82	83	77	74	72	67	84	83	81	80
65	83	82	82	83	77	74	72	67	84	83	81	80
70	85	82	82	83	77	74	72	67	84	83	82	81
75/76	85	82	83	83	78	78	74	67	85	84	82	81
80/81	85	83	83	83	80	78	74	68	85	85	83	82
90/91	85	84	84	83	80	77	74	68	85	84	82	81
100/101	87	83	83	83	80	77	75	68	85	84	82	81
110	87	83	84	83	79	76	73	68	85	84	82	81
120	88	82	85	83	79	78	76	69	86	85	83	82
130	88	82	85	83	79	78	77	69	86	85	83	82
140	88	83	87	84	79	78	77	69	86	85	83	82
150	89	84	88	84	81	81	79	69	88	87	85	84
161	90	85	88	84	82	81	79	69	88	87	85	84
170	89	85	86	86	83	79	77	71	88	87	85	84
180	89	85	86	86	83	79	77	71	88	87	85	84
191	89	85	86	86	83	79	77	71	88	87	85	84
211	90	85	87	86	86	81	78	71	89	89	87	86
226	91	85	88	86	86	81	79	72	90	89	87	86
241	91	85	88	87	88	81	79	72	91	90	88	87

**Table 12: 50 Hz Sound Pressure (at 30 feet from side of unit)**

Model	Octave Band at Center Frequency, 30 ft. from unit								Overall A-Weighted			
	63	125	250	500	1000	2000	4000	8000	Without Sound Insulation	75% Load	50% Load	25% Load
30	62	61	58	57	53	48	43	38	58	57	55	54
35	62	61	59	57	53	48	43	38	58	57	55	54
40	62	61	60	58	54	49	44	39	59	58	56	55
45	63	62	61	59	55	49	44	39	60	59	57	56
50	63	63	61	59	55	49	44	39	60	59	57	56
55	63	63	63	59	56	51	46	41	61	60	58	57
60	64	63	64	59	56	51	46	41	61	60	58	57
65	65	64	64	59	57	51	46	41	62	61	59	58
70	65	65	64	59	57	51	46	41	62	61	60	59
75/76	65	65	65	59	57	51	46	41	62	61	59	58
80/81	63	60	60	60	59	53	50	49	63	62	60	59
90/91	64	64	64	61	59	53	51	51	64	63	61	60
100/101	63	65	62	62	59	53	54	52	64	63	61	60
110	63	66	64	62	58	52	52	52	64	63	61	60
120	65	64	64	62	58	56	57	54	65	64	62	61
130	64	65	65	61	58	57	57	52	65	64	62	61
140	65	66	66	62	58	57	58	53	66	65	63	62
150	66	67	67	62	59	59	59	53	67	66	64	63
161	66	67	67	62	59	60	59	53	67	66	64	63
170	66	68	66	64	61	58	57	55	67	66	64	63
180	66	68	66	64	61	58	58	55	67	66	64	63
191	66	68	66	64	61	58	58	55	67	66	64	63
211	67	68	67	64	63	59	59	55	68	67	65	64
226	67	68	67	64	63	59	59	56	68	67	65	64
241	67	68	67	65	64	59	59	56	69	68	66	65

**Table 13: 50 Hz Sound Pressure (at 30 ft from side of unit) with Sound Insulation**

Model	Octave Band at Center Frequency, 30 ft. from unit								Overall A-Weighted			
	63	125	250	500	1000	2000	4000	8000	With Sound Insulation	75% Load	50% Load	25% Load
30	54	54	53	54	47	45	44	40	55	54	52	51
35	54	54	53	54	47	45	44	40	55	54	52	51
40	54	54	53	54	47	45	44	40	55	54	52	51
45	55	55	55	56	50	47	45	40	57	56	54	53
50	55	55	55	56	50	47	45	40	57	56	54	53
55	55	55	55	56	50	47	45	40	57	56	54	53
60	55	55	55	56	50	47	45	40	57	56	54	53
65	56	55	55	56	50	47	45	40	57	56	54	53
70	58	55	55	56	50	47	45	40	57	56	55	54
75/76	58	55	56	56	51	51	47	40	58	57	55	54
80/81	58	55	56	56	53	51	47	41	58	58	56	55
90/91	58	57	57	56	53	50	47	41	58	57	55	54
100/101	60	56	56	56	53	50	48	41	58	57	55	54
110	60	56	57	56	52	49	46	41	58	57	55	54
120	61	55	58	56	52	51	48	42	58	58	56	55
130	61	55	58	56	53	51	48	42	59	58	56	55
140	61	56	59	57	53	51	50	42	60	59	57	56
150	62	57	60	57	54	53	51	42	60	60	57	57
161	62	57	60	57	55	53	51	42	61	60	58	57
170	62	58	59	59	56	52	50	44	61	60	58	57
180	62	58	59	59	57	53	51	44	61	60	58	57
191	62	58	59	59	57	53	51	44	61	60	58	57
211	63	58	60	59	59	54	52	44	63	62	60	59
226	63	58	60	59	59	54	52	45	63	62	60	59
241	63	58	60	60	60	54	52	45	63	63	61	60

Figure 30: Pressure Drop Curves - Unit Evaporator - AGZ030-AGZ090E (Reference Table 14 on page 23)

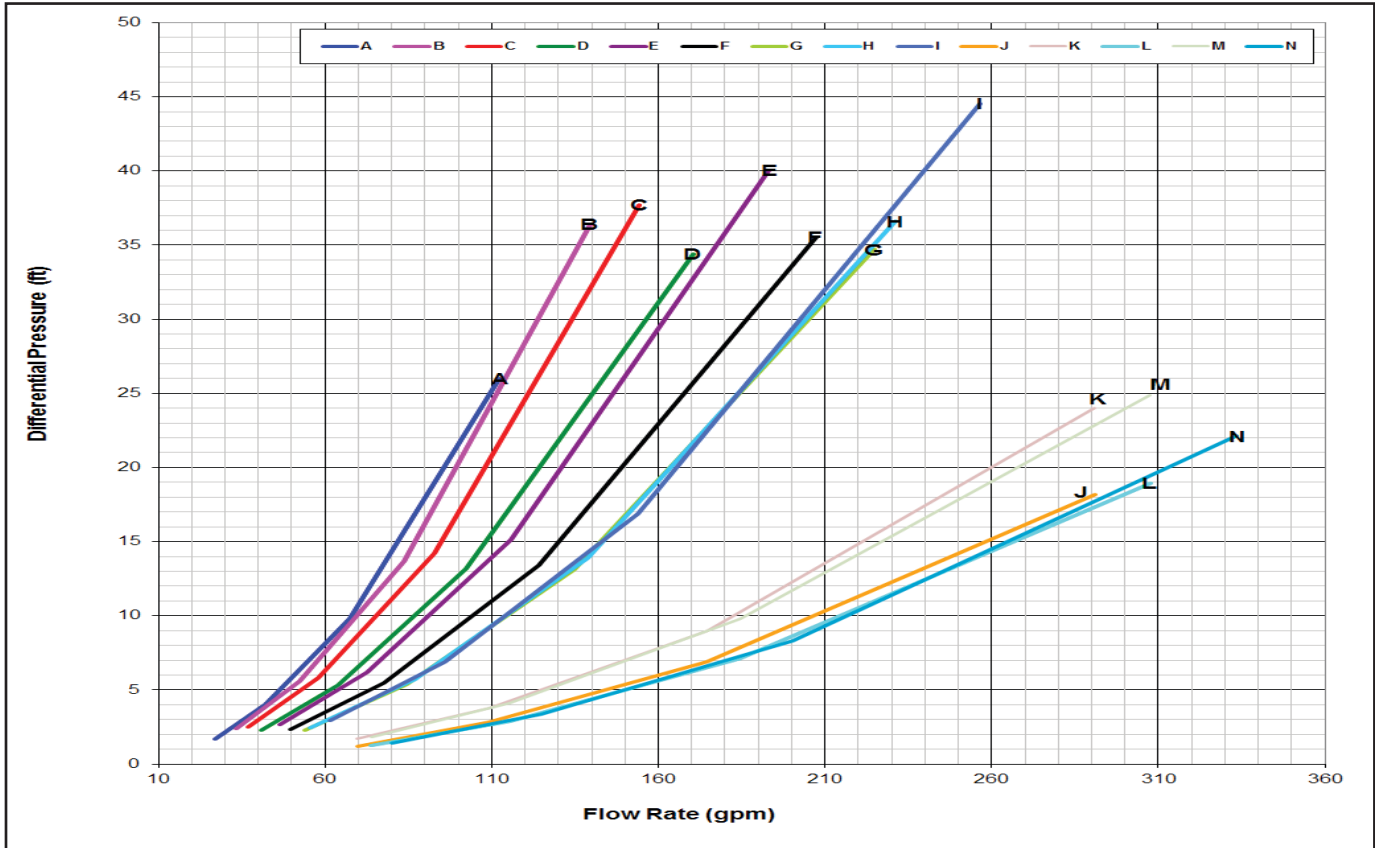
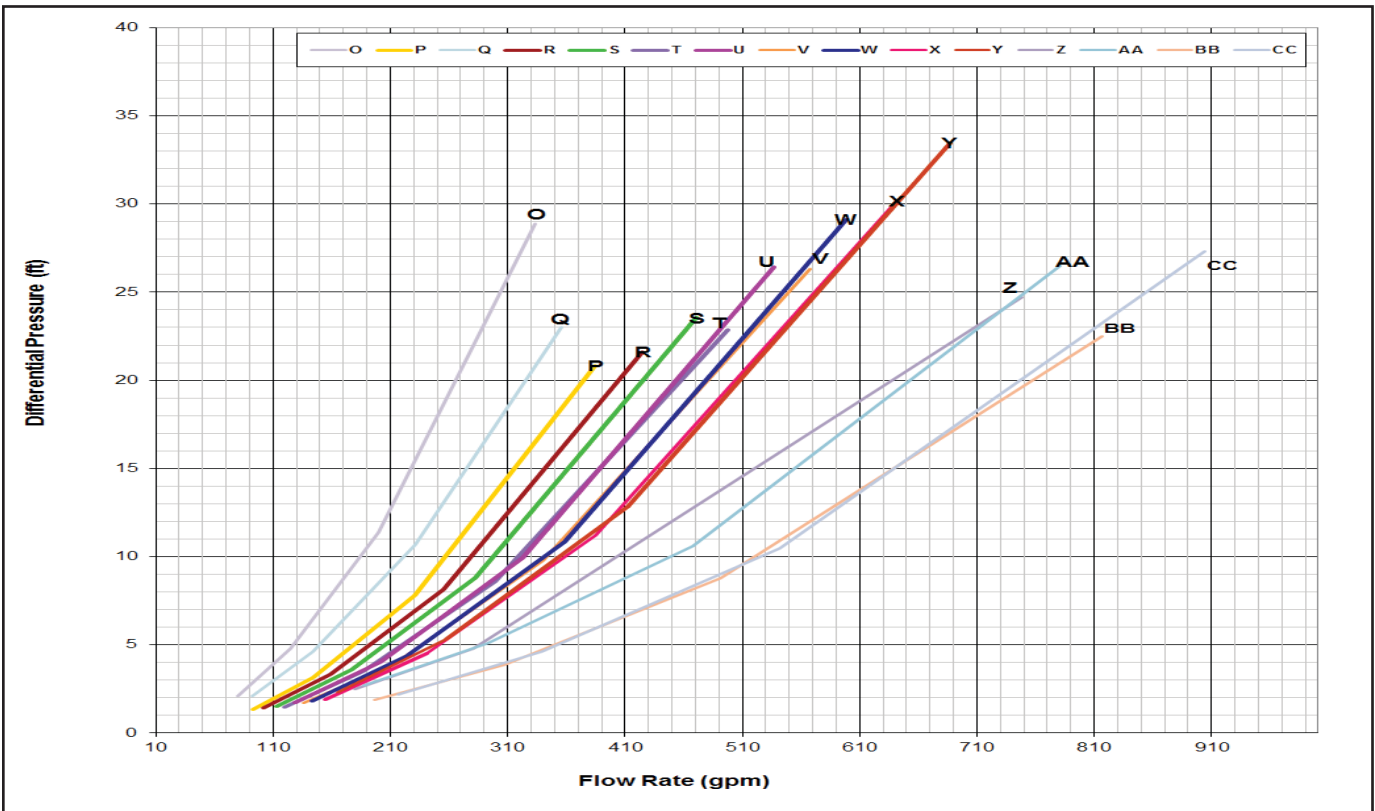

Figure 31: Pressure Drop Curves - Unit Evaporator - AGZ091-AGZ-241E (Reference Table 14 on page 23)



**Table 14: Pressure Drop Data - Unit Evaporator**

Curve Ref.	Model	Part Load Flow System Only Minimum Flow Rate <sup>2</sup>				Full Load Flow System Only Minimum Flow Rate <sup>1</sup>				Fixed and Variable Flow Systems							
		IP		SI		IP		SI		Nominal Flow Rate				Maximum Flow Rate			
		GPM	DP ft.	lps	DP kpa	GPM	DP ft.	lps	DP kpa	GPM	DP ft.	lps	DP kpa	GPM	DP ft.	lps	DP kpa
A	030E	27.0	1.7	1.7	5.1	42.2	4.0	2.7	12.0	67.4	9.8	4.3	29.4	112.4	26.0	7.1	77.7
B	035E	33.5	2.4	2.1	7.1	52.4	5.6	3.3	16.7	83.8	13.7	5.3	40.9	139.6	36.4	8.8	108.7
C	040E	37.1	2.5	2.3	7.4	57.9	5.8	3.7	17.3	92.6	14.2	5.8	42.5	154.4	37.7	9.7	112.6
D	045E	40.9	2.3	2.6	6.8	63.9	5.3	4.0	15.8	102.2	13.2	6.5	39.4	170.4	34.4	10.8	102.7
E	050E	46.4	2.7	2.9	7.9	72.5	6.2	4.6	18.5	115.9	15.2	7.3	45.3	193.2	40.0	12.2	119.6
F	055E	49.7	2.3	3.1	7.0	77.7	5.5	4.9	16.3	124.3	13.4	7.8	40.0	207.2	35.6	13.1	106.2
G	060E	54.0	2.3	3.4	6.9	84.3	5.4	5.3	16.1	134.9	13.1	8.5	39.3	224.8	34.7	14.2	103.6
H	065E	55.5	2.4	3.5	7.3	86.7	5.7	5.5	17.0	138.7	13.9	8.8	41.4	231.2	36.6	14.6	109.3
I	070E	61.5	3.0	3.9	8.8	96.1	6.9	6.1	20.6	153.8	16.9	9.7	50.4	256.4	44.5	16.2	133.0
J	075E	69.8	1.2	4.4	3.6	109.1	2.8	6.9	8.4	174.5	6.9	11.0	20.5	290.8	18.2	18.3	54.3
K	076E	69.8	1.7	4.4	5.1	109.1	3.8	6.9	11.4	174.5	9.0	11.0	26.9	290.8	24.0	18.3	71.8
L	080E	73.8	1.2	4.7	3.7	115.4	2.9	7.3	8.6	184.6	7.1	11.6	21.3	307.6	18.9	19.4	56.6
M	081E	73.8	1.8	4.7	5.5	115.4	4.1	7.3	12.4	184.6	9.8	11.6	29.3	307.6	24.9	19.4	74.6
N	090E	80.1	1.4	5.1	4.3	125.1	3.4	7.9	10.1	200.2	8.3	12.6	24.8	333.6	22.1	21.0	66.1
O	091E	80.1	2.1	5.1	5.3	125.1	4.8	7.9	14.4	200.2	11.4	12.6	34.0	333.6	28.9	21.0	86.5
P	100E	92.4	1.3	5.8	4.0	144.3	3.2	9.1	9.5	230.9	7.8	14.6	23.3	384.8	20.8	24.3	62.2
Q	101E	92.4	2.1	5.8	6.3	144.3	4.6	9.1	13.9	230.9	7.7	14.6	31.9	356.0	23.0	22.5	68.8
R	110E	102.0	1.4	6.4	4.2	159.5	3.3	10.1	9.9	255.1	8.2	16.1	24.4	425.2	21.6	26.8	64.6
S	120E	113.1	1.5	7.1	4.5	176.7	3.6	11.1	10.7	282.7	8.8	17.8	26.4	471.2	23.5	29.7	70.3
T	130E	119.5	1.5	7.5	4.4	186.8	3.5	11.8	10.4	298.8	8.6	18.9	25.7	498.0	22.9	31.4	68.3
U	140E	128.9	1.7	8.1	5.1	201.5	4.0	12.7	12.1	322.3	9.9	20.3	29.7	537.2	26.4	33.9	79.0
V	150E	136.1	1.7	8.6	4.9	212.7	3.9	13.4	11.7	340.3	9.8	21.5	29.2	567.2	26.3	35.8	78.4
W	161E	143.6	1.8	9.1	5.5	224.4	4.4	14.2	13.0	359.0	10.8	22.7	32.4	598.4	29.1	37.8	87.0
X	170E	154.1	1.9	9.7	5.6	240.8	4.5	15.2	13.4	385.2	11.2	24.3	33.4	642.0	30.2	40.5	90.2
Y	180E	164.8	2.3	10.4	6.9	257.6	5.3	16.2	15.9	412.1	12.8	26.0	38.3	686.8	33.5	43.3	99.9
Z	191E	179.6	2.5	11.3	7.5	280.6	4.8	17.7	14.3	449.0	9.9	28.3	29.6	748.5	24.7	47.2	74.0
AA	211E	187.2	2.7	11.8	8.0	292.5	5.1	18.4	15.2	468.0	10.6	29.5	31.7	780.2	26.5	49.1	79.1
BB	226E	196.8	1.9	12.4	5.6	307.5	3.9	19.4	11.6	492.0	8.8	31.0	26.4	816.7	22.5	51.5	67.3
CC	241E	216.8	2.2	13.7	6.5	338.8	4.6	21.3	13.7	542.0	10.5	34.1	31.5	903.5	27.3	56.9	81.5

Figure 32: Pressure Drop Curves - Heat Recovery Auxilliary Heat Exchangers (Reference Table 15)

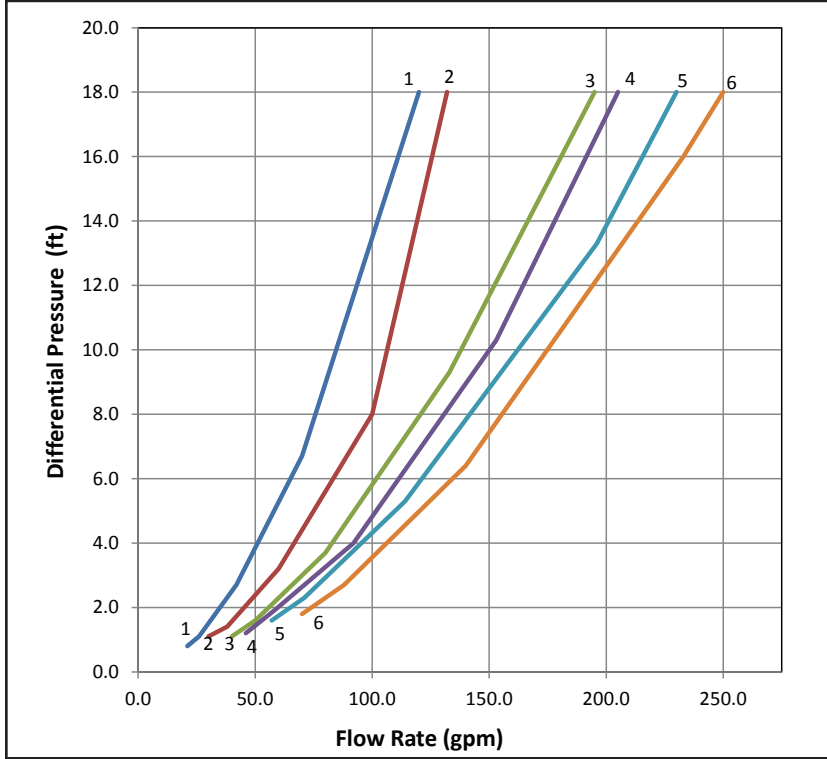

Table 15: Pressure Drop Data - Heat Recovery Auxilliary Brazed Plate Heat Exchangers

Ref.	Unit Model	Minimum Flow				Nominal Flow				Maximum Flow			
		(GPM)	Dp (ft)	l/s	DP kpa	(GPM)	Dp (ft)	l/s	DP kpa	(GPM)	Dp (ft)	l/s	DP kpa
1	AGZ075/076	21	0.8	1.3	2.3	42	2.7	2.7	8.1	120	18.0	7.6	53.8
	AGZ080/081												
	AGZ090/091												
2	AGZ100/101	30	1.1	1.9	3.2	60	3.2	3.8	9.6	132	18.0	8.3	53.8
	AGZ110												
	AGZ120												
3	AGZ130	40	1.1	2.5	3.3	80	3.7	5.0	11.1	195	18.0	12.3	53.8
	AGZ140												
4	AGZ150	46	1.2	2.9	3.7	92	4.0	5.8	12.0	205	18.0	12.9	53.8
	AGZ161												
5	AGZ170	57	1.6	3.6	4.7	114	5.3	7.2	15.8	230	18.0	14.5	53.8
	AGZ180												
	AGZ191												
	AGZ211												
6	AGZ226	70	1.8	4.4	5.3	140	6.4	8.8	19.1	250	18.0	15.8	53.8
	AGZ241												



**Table 16: Physical Data - AGZ030E - AGZ040E**

Physical Data	AGZ-E (Microchannel Packaged Chiller)					
	AGZ030E		AGZ035E		AGZ040E	
	CIRCUIT 1	CIRCUIT 2	CIRCUIT 1	CIRCUIT 2	CIRCUIT 1	CIRCUIT 2
<b>BASIC DATA</b>						
Unit Operating Charge lbs (kg) - Sealed Filter Drier	15 (16.8)	15 (16.8)	14 (6.4)	14 (6.4)	21 (9.5)	21 (9.5)
- Replaceable Core Filter Drier	17 (7.7)	17 (7.7)	16 (7.3)	16 (7.3)	23 (10.5)	23 (10.5)
<b>COMPRESSORS, SCROLL, HERMETIC</b>						
Nominal HP	7.5 / 7.5	7.5 / 7.5	9.0 / 9.0	10.0 / 10.0	10.0 / 10.0	10.0 / 10.0
Oil charge per Compressor, oz (g)	85 (2410)	85 (2410)	85 (2410)	85 (2410)	85 (2410)	85 (2410)
	85 (2410)	85 (2410)	85 (2410)	85 (2410)	85 (2410)	85 (2410)
Staging, 4 Stages (If Circuit is in Lead)	0-25-50-75-100	0-25-50-75-100	0-23-50-73-100	0-27-50-77-100	0-25-50-75-100	0-25-50-75-100
<b>CONDENSER, MICROCHANNEL</b>						
Coil Inlet Face Area, sq. ft. (sq. m.)	24.9 (2.3)	24.9 (2.3)	24.9 (2.3)	24.9 (2.3)	49.8 (4.6)	49.8 (4.6)
Rows Deep/Fins Per Inch	1 / 21	1 / 21	1 / 21	1 / 21	1 / 21	1 / 21
<b>CONDENSER FANS, DIRECT DRIVE PROPELLER</b>						
# of Fans per Circuit - Fan Diameter in. (mm)	2 - 30 (762)	2 - 30 (762)	2 - 30 (762)	2 - 30 (762)	2 - 30 (762)	2 - 30 (762)
Fan Motor, hp (kW) (for 208V,230V,460V/60Hz) <sup>1</sup>	1.5 (1.1)		1.5 (1.1)		1.5 (1.1)	
Fan & Motor RPM (for all 60Hz) <sup>1</sup>	1140		1140		1140	
Airflow, cfm (l/s) <sup>1</sup>	34,000 (16,047)		34,000 (16,047)		40,400 (19,067)	
<b>EVAPORATOR, BRAZED PLATE<sup>3</sup></b>						
Dry Weight lbs (kg)	84 (38.1)		91 (41.3)		98 (44.5)	
Water Volume, gallons (liters)	1.6 (6.1)		1.8 (6.8)		1.9 (7.2)	
Grooved inlet/outlet connection, in. (mm) <sup>2</sup>	2.5 (65)		2.5 (65)		2.5 (65)	
Max. Water Pressure, psi (kPa)	653 (4502)		653 (4502)		653 (4502)	
Max. Refrigerant Pressure, psi (kPa)	653 (4502)		653 (4502)		653 (4502)	

**Table 17: Physical Data - AGZ045E - AGZ055E**

Physical Data	AGZ-E (Microchannel Packaged Chiller)					
	AGZ045E		AGZ050E		AGZ055E	
	CIRCUIT 1	CIRCUIT 2	CIRCUIT 1	CIRCUIT 2	CIRCUIT 1	CIRCUIT 2
<b>BASIC DATA</b>						
Unit Operating Charge lbs (kg)	21 (9.5)	21 (9.5)	21 (9.5)	21 (9.5)	21 (9.5)	21 (9.5)
- Replaceable Core Filter Drier (Microchannel only)	23 (10.5)	23 (10.5)	23 (10.5)	23 (10.5)	23 (10.5)	23 (10.5)
<b>COMPRESSORS, SCROLL, HERMETIC</b>						
Nominal HP	12.0 / 12.0	12.0 / 12.0	13.0 / 13.0	13.0 / 13.0	13.0 / 13.0	15.0 / 15.0
Oil charge per Compressor, oz (g)	110 (3119)	110 (3119)	110 (3119)	110 (3119)	110 (3119)	110 (3119)
	110 (3119)	110 (3119)	110 (3119)	110 (3119)	110 (3119)	110 (3119)
Staging, 4 Stages (If Circuit is in Lead)	0-25-50-75-100	0-25-50-75-100	0-25-50-75-100	0-25-50-75-100	0-23-50-73-100	0-27-50-77-100
<b>CONDENSER, MICROCHANNEL</b>						
Coil Inlet Face Area, sq. ft. (sq. m.)	49.8 (4.6)	49.8 (4.6)	49.8 (4.6)	49.8 (4.6)	49.8 (4.6)	49.8 (4.6)
Rows Deep/Fins Per Inch	1 / 21	1 / 21	1 / 21	1 / 21	1 / 21	1 / 21
<b>CONDENSER FANS, DIRECT DRIVE PROPELLER</b>						
# of Fans per Circuit - Fan Diameter in. (mm)	2 - 30 (762)	2 - 30 (762)	2 - 30 (762)	2 - 30 (762)	2 - 30 (762)	2 - 30 (762)
Fan Motor, hp (kW) (for 208V,230V,460V/60Hz) <sup>1</sup>	1.5 (1.1)		1.5 (1.1)		1.5 (1.1)	
Fan & Motor RPM (for all 60Hz) <sup>1</sup>	1140		1140		1140	
Airflow, cfm (l/s) <sup>1</sup>	40,400 (19,067)		40,400 (19,067)		40,400 (19,067)	
<b>EVAPORATOR, BRAZED PLATE<sup>3</sup></b>						
Dry Weight lbs (kg)	112 (50.1)		126 (57.2)		133 (60.3)	
Water Volume, gallons (liters)	2.3 (8.7)		2.6 (9.8)		2.8 (10.6)	
Grooved inlet/outlet connection, in. (mm) <sup>2</sup>	2.5 (65)		2.5 (65)		2.5 (65)	
Max. Water Pressure, psi (kPa)	653 (4502)		653 (4502)		653 (4502)	
Max. Refrigerant Pressure, psi (kPa)	653 (4502)		653 (4502)		653 (4502)	

**NOTE:** 1) **Models 030-060:** Fan Motor hp = 2.0 for 380V/60Hz, 575V/60Hz, & 400V/50Hz.  
**All Models:** Fan RPM = 950 for 400V/50Hz. Airflow = (0.83 x 60Hz Airflow) for 400V/50Hz.  
 2) Water connection shown is nominal pipe size.  
 3) Brazed plate evaporators do not have drain or vent connections integral to the heat exchanger. The connections must be installed in the field inlet and outlet piping as shown in Piping Section in the current version of the Installation and Operation Manual, available on [www.DaikinApplied.com](http://www.DaikinApplied.com).

**Table 18: Physical Data - AGZ060E - AGZ070E**

Physical Data	AGZ-E (Microchannel Packaged Chiller)					
	AGZ060E		AGZ065E		AGZ070E	
	CIRCUIT 1	CIRCUIT 2	CIRCUIT 1	CIRCUIT 2	CIRCUIT 1	CIRCUIT 2
<b>BASIC DATA</b>						
Unit Operating Charge lbs (kg) - Sealed Filter Drier	21 (9.5)	21 (9.5)	21 (9.5)	21 (9.5)	21 (9.5)	21 (9.5)
- Replaceable Core Filter Drier	23 (10.5)	23 (10.5)	23 (10.5)	23 (10.5)	23 (10.5)	23 (10.5)
<b>COMPRESSORS, SCROLL, HERMETIC</b>						
Nominal HP	15.0 / 15.0	15.0 / 15.0	15.0 / 15.0	15.0 / 15.0	15.0 / 20.0	15.0 / 20.0
Oil charge per Compressor, oz (g)	110 (3119)	110 (3119)	110 (3119)	110 (3119)	110 (3119)	110 (3119)
	110 (3119)	110 (3119)	110 (3119)	110 (3119)	152 (4309)	152 (4309)
Staging, 4 Stages (If Circuit is in Lead)	0-25-50-75-100	0-25-50-75-100	0-25-50-75-100	0-25-50-75-100	0-21-50-71-100	0-28-50-78-100
<b>CONDENSER, MICROCHANNEL</b>						
Coil Inlet Face Area, sq. ft. (sq. m.)	49.8 (4.6)	49.8 (4.6)	49.8 (4.6)	49.8 (4.6)	49.8 (4.6)	49.8 (4.6)
Rows Deep/Fins Per Inch	1 / 21	1 / 21	1 / 21	1 / 21	1 / 21	1 / 21
<b>CONDENSER FANS, DIRECT DRIVE PROPELLER</b>						
# of Fans per Circuit - Fan Diameter in. (mm)	2 - 30 (762)	2 - 30 (762)	2 - 30 (762)	2 - 30 (762)	2 - 30 (762)	2 - 30 (762)
Fan Motor, hp (kW) (for 208V,230V,460V/60Hz) <sup>1</sup>	1.5 (1.1)		2.0 (1.5)		2.0 (1.5)	
Fan & Motor RPM (for all 60Hz) <sup>1</sup>	1140		1140		1140	
Airflow, cfm (l/s) <sup>1</sup>	40,400 (19,067)		48,000 (22654)		48,000 (22654)	
<b>EVAPORATOR, BRAZED PLATE<sup>3</sup></b>						
Dry Weight lbs (kg)	150 (68.1)		150 (68.1)		150 (68.1)	
Water Volume, gallons (liters)	3.2 (12.1)		3.2 (12.1)		3.2 (12.1)	
Grooved inlet/outlet connection, in. (mm) <sup>2</sup>	2.5 (65)		2.5 (65)		2.5 (65)	
Max. Water Pressure, psi (kPa)	653 (4502)		653 (4502)		653 (4502)	
Max. Refrigerant Pressure, psi (kPa)	653 (4502)		653 (4502)		653 (4502)	

**Table 19: Physical Data - AGZ075E - AGZ091E**

Physical Data	AGZ-E (Microchannel Packaged Chiller)					
	AGZ075/076E		AGZ080/081E		AGZ090/091E	
	CIRCUIT 1	CIRCUIT 2	CIRCUIT 1	CIRCUIT 2	CIRCUIT 1	CIRCUIT 2
<b>BASIC DATA</b>						
Unit Operating Charge lbs (kg)	46 (20.9)	46 (20.9)	46 (20.9)	46 (20.9)	48 (21.8)	48 (21.8)
- Replaceable Core Filter Drier (Microchannel only)						
<b>COMPRESSORS, SCROLL, HERMETIC</b>						
Nominal HP	20.0 / 20.0	20.0 / 15.0	20.0 / 20.0	20.0 / 20.0	25.0 / 20.0	20.0 / 25.0
Oil charge per Compressor, oz (g)	152 (4495)	152 (4495)	152 (4495)	152 (4495)	152 (4495)	152 (4495)
	152 (4495)	110 (3253)	152 (4495)	152 (4495)	152 (4495)	152 (4495)
Staging, 4 Stages (If Circuit is in Lead)	0-27-47-73-100	0-25-50-75-100	0-25-50-75-100	0-25-50-75-100	0-28-50-72-100	0-22-50-78-100
<b>CONDENSER, MICROCHANNEL</b>						
Coil Inlet Face Area, sq. ft. (sq. m.)	79.5 (7.4)	79.5 (7.4)	79.5 (7.4)	79.5 (7.4)	79.5 (7.4)	79.5 (7.4)
Rows Deep/Fins Per Inch	1 / 21	1 / 21	1 / 21	1 / 21	1 / 21	1 / 21
<b>CONDENSER FANS, DIRECT DRIVE PROPELLER</b>						
# of Fans per Circuit - Fan Diameter in. (mm)	3 - 30 (762)	3 - 30 (762)	3 - 30 (762)	3 - 30 (762)	3 - 30 (762)	3 - 30 (762)
Fan Motor, hp (kW)	2.0 (1.5)		2.0 (1.5)		2.0 (1.5)	
Fan & Motor RPM (for all 60Hz) <sup>1</sup>	1140		1140		1140	
Airflow, cfm (l/s) <sup>1</sup>	67,740 (31,970)		67,740 (31,970)		67,740 (31,970)	
<b>EVAPORATOR, BRAZED PLATE<sup>3</sup></b>						
Dry Weight lbs (kg)	244 (111)		266 (121)		266 (121)	
Water Volume, gallons (liters)	7.9 (30)		8.7 (33)		8.7 (33)	
Grooved inlet/outlet connection, in. (mm) <sup>2</sup>	3.0 (77)		3.0 (77)		3.0 (77)	
Max. Water Pressure, psi (kPa)	650 (4482)		650 (4482)		650 (4482)	
Max. Refrigerant Pressure, psi (kPa)	650 (4482)		650 (4482)		650 (4482)	

**NOTE:** 1) **Models 030-060:** Fan Motor hp = 2.0 for 380V/60Hz, 575V/60Hz, & 400V/50Hz.

**All Models:** Fan RPM = 950 for 400V/50Hz. Airflow = (0.83 x 60Hz Airflow) for 400V/50Hz.

2) Water connection shown is nominal pipe size.

3) Brazed plate evaporators do not have drain or vent connections integral to the heat exchanger. The connections must be installed in the field inlet and outlet piping as shown in Piping Section in the current version of the Installation and Operation Manual, available on [www.DaikinApplied.com](http://www.DaikinApplied.com).

**Table 20: Physical Data - AGZ100E - AGZ120E**

Physical Data	AGZ-E (Microchannel Packaged Chiller)					
	AGZ100/101E		AGZ110E		AGZ120E	
	CIRCUIT 1	CIRCUIT 2	CIRCUIT 1	CIRCUIT 2	CIRCUIT 1	CIRCUIT 2
<b>BASIC DATA</b>						
Unit Operating Charge lbs (kg) - Replaceable Core Filter Drier (Microchannel only)	49 (22.3)	49 (22.3)	64 (29.1)	64 (29.1)	65 (29.5)	65 (29.5)
<b>COMPRESSORS, SCROLL, HERMETIC</b>						
Nominal HP	25.0 / 25.0	25.0 / 30.0	30.0 / 25.0	25.0 / 30.0	30.0 / 30.0	30.0 / 30.0
Oil charge per Compressor, oz (g)	152 (4495)	152 (4495)	213 (6299)	152 (4495)	213 (6299)	213 (6299)
	152 (4495)	213 (6299)	152 (4495)	213 (6299)	213 (6299)	213 (6299)
Staging, 4 Stages (If Circuit is in Lead)	0-24-48-71-100	0-24-48-76-100	0-27-50-73-100	0-23-50-77-100	0-25-50-75-100	0-25-50-75-100
<b>CONDENSER, MICROCHANNEL</b>						
Coil Inlet Face Area, sq. ft. (sq. m.)	79.5 (7.4)	79.5 (7.4)	106 (9.9)	106 (9.9)	106 (9.9)	106 (9.9)
Rows Deep/Fins Per Inch	1 / 21	1 / 21	1 / 21	1 / 21	1 / 21	1 / 21
<b>CONDENSER FANS, DIRECT DRIVE PROPELLER</b>						
# of Fans per Circuit - Fan Diameter in. (mm)	3 - 30 (762)	3 - 30 (762)	4 - 30 (762)	4 - 30 (762)	4 - 30 (762)	4 - 30 (762)
Fan Motor, hp (kW)	2.0 (1.5)		2.0 (1.5)		2.0 (1.5)	
Fan & Motor RPM (for all 60Hz) <sup>1</sup>	1140		1140		1140	
Airflow, cfm (l/s) <sup>1</sup>	67,740 (31,970)		90,320 (42,627)		90,320 (42,627)	
<b>EVAPORATOR, BRAZED PLATE<sup>3</sup></b>						
Dry Weight lbs (kg)	317 (144)		339 (154)		369 (168)	
Water Volume, gallons (liters)	10.6 (41)		11.4 (44)		12.5 (48)	
Grooved inlet/outlet connection, in. (mm) <sup>2</sup>	3.0 (77)		3.0 (77)		3.0 (77)	
Max. Water Pressure, psi (kPa)	650 (4482)		650 (4482)		650 (4482)	
Max. Refrigerant Pressure, psi (kPa)	650 (4482)		650 (4482)		650 (4482)	

**Table 21: Physical Data - AGZ130E - AGZ161E**

Physical Data	AGZ-E (Microchannel Packaged Chiller)							
	AGZ130E		AGZ140E		AGZ150E		AGZ161E	
	CIRCUIT 1	CIRCUIT 2	CIRCUIT 1	CIRCUIT 2	CIRCUIT 1	CIRCUIT 2	CIRCUIT 1	CIRCUIT 2
<b>BASIC DATA</b>								
Unit Operating Charge lbs (kg) - Replaceable Core Filter Drier (Microchannel only)	65 (29.5)	65 (29.5)	76 (34.5)	76 (34.5)	76 (34.5)	76 (34.5)	78 (34.5)	78 (34.5)
<b>COMPRESSORS, SCROLL, HERMETIC</b>								
Nominal HP	30.0 / 30.0	30.0 / 40.0	40.0 / 30.0	30.0 / 40.0	40.0 / 30.0	40.0 / 40.0	40.0 / 40.0	40.0 / 40.0
Oil charge per Compressor, oz (g)	213 (6299)	213 (6299)	213 (6299)	213 (6299)	213 (6299)	213 (6299)	213 (6299)	213 (6299)
	213 (6299)	213 (6299)	213 (6299)	213 (6299)	213 (6299)	213 (6299)	213 (6299)	213 (6299)
Staging, 4 Stages (If Circuit is in Lead)	0-23-46-69-100	0-23-46-77-100	0-29-50-71-100	0-21-50-79-100	0-27-50-73-100	0-27-53-80-100	0-27-53-80-100	0-27-53-80-100
<b>CONDENSER, MICROCHANNEL</b>								
Coil Inlet Face Area, sq. ft. (sq. m.)	106 (9.9)	106 (9.9)	132.4 (12.4)	132.4 (12.4)	132.4 (12.4)	132.4 (12.4)	132.4 (12.4)	132.4 (12.4)
Rows Deep/Fins Per Inch	1 / 21	1 / 21	1 / 21	1 / 21	1 / 21	1 / 21	1 / 21	1 / 21
<b>CONDENSER FANS, DIRECT DRIVE PROPELLER</b>								
# of Fans per Circuit - Fan Diameter in. (mm)	4 - 30 (762)	4 - 30 (762)	5 - 30 (762)	5 - 30 (762)	5 - 30 (762)	5 - 30 (762)	5 - 30 (762)	5 - 30 (762)
Fan Motor, hp (kW)	2.0 (1.5)		2.0 (1.5)		2.0 (1.5)		2.0 (1.5)	
Fan & Motor RPM (for all 60Hz) <sup>1</sup>	1140		1140		1140		1140	
Airflow, cfm (l/s) <sup>1</sup>	90,320 (42,627)		112,900 (53,283)		112,900 (53,283)		112,900 (53,283)	
<b>EVAPORATOR, BRAZED PLATE<sup>3</sup></b>								
Dry Weight lbs (kg)	406 (185)		435 (198)		465 (211)		465 (211)	
Water Volume, gallons (liters)	13.8 (53)		15.0 (57)		16.1 (61)		16.1 (61)	
Grooved inlet/outlet connection, in. (mm) <sup>2</sup>	3.0 (77)		4.0 (102)		4.0 (102)		4.0 (102)	
Max. Water Pressure, psi (kPa)	650 (4482)		650 (4482)		650 (4482)		650 (4482)	
Max. Refrigerant Pressure, psi (kPa)	650 (4482)		650 (4482)		650 (4482)		650 (4482)	

**NOTE:** 1) All Models: Fan RPM = 950 for 400V/50Hz. Airflow = (0.83 x 60Hz Airflow) for 400V/50Hz.  
 2) Water connection shown is nominal pipe size.  
 3) Brazed plate evaporators do not have drain or vent connections integral to the heat exchanger. The connections must be installed in the field inlet and outlet piping as shown in Piping Section in the current version of the Installation and Operation Manual, available on [www.DaikinApplied.com](http://www.DaikinApplied.com).

**Table 22: Physical Data - AGZ170E - AGZ180E**

Physical Data	AGZ-E (Microchannel Packaged Chiller)			
	AGZ170E		AGZ180E	
	CIRCUIT 1	CIRCUIT 2	CIRCUIT 1	CIRCUIT 2
<b>BASIC DATA</b>				
Unit Operating Charge lbs (kg) - Replaceable Core Filter Drier	80 (36.3)	80 (36.3)	80 (36.3)	80 (36.3)
<b>COMPRESSORS, SCROLL, HERMETIC</b>				
Nominal HP	25 / 25 / 30	30 / 30 / 30	30 / 30 / 30	30 / 30 / 30
Oil charge per Compressor, oz (g)	152 (4495)	213 (6299)	213 (6299)	213 (6299)
	152 (4495)	213 (6299)	213 (6299)	213 (6299)
	213 (6299)	213 (6299)	213 (6299)	213 (6299)
Staging, 6 Stages (If Circuit is in Lead)	0-15-32-47-65-82-100	0-18-32-50-65-82-100	0-17-33-50-67-83-100	0-17-33-50-67-83-100
<b>CONDENSER, MICROCHANNEL</b>				
Coil Inlet Face Area, sq. ft. (sq. m.)	132.4 (12.4)	132.4 (12.4)	132.4 (12.4)	132.4 (12.4)
Rows Deep/Fins Per Inch	1 / 21	1 / 21	1 / 21	1 / 21
<b>CONDENSER FANS, DIRECT DRIVE PROPELLER</b>				
# of Fans per Circuit - Fan Diameter in (mm)	5 - 30 (762)	5 - 30 (762)	5 - 30 (762)	5 - 30 (762)
Fan Motor, hp (kW)	2.0 (1.5)		2.0 (1.5)	
Fan & Motor RPM (for all 60Hz) <sup>1</sup>	1140		1140	
Airflow, cfm (l/s) <sup>1</sup>	112,900 (53,283)		112,900 (53,283)	
<b>EVAPORATOR, BRAZED PLATE<sup>3</sup></b>				
Dry Weight lbs (kg)	494 (225)		531 (241)	
Water Volume, gallons (liters)	17.1 (65)		18.6 (71)	
Grooved inlet/outlet connection, in. (mm) <sup>2</sup>	4.0 (102)		4.0 (102)	
Max. Water Pressure, psi (kPa)	650 (4482)		650 (4482)	
Max. Refrigerant Pressure, psi (kPa)	650 (4482)		650 (4482)	

**Table 23: Physical Data - AGZ191-241E**

Physical Data	AGZ-E (Microchannel Packaged Chiller)							
	AGZ191E		AGZ211E		AGZ226E		AGZ241E	
	CIRCUIT 1	CIRCUIT 2	CIRCUIT 1	CIRCUIT 2	CIRCUIT 1	CIRCUIT 2	CIRCUIT 1	CIRCUIT 2
<b>BASIC DATA</b>								
Unit Operating Charge lbs (kg) - Replaceable Core Filter Drier (Microchannel only)	87 (39.5)	87 (39.5)	91 (41.3)	91 (41.3)	107 (48.6)	107 (48.6)	111 (50.4)	111 (50.4)
<b>COMPRESSORS, SCROLL, HERMETIC</b>								
Nominal HP	30 / 30 / 30	30 / 40 / 30	30 / 40 / 30	30 / 40 / 30	30 / 40 / 30	40 / 30 / 40	40 / 40 / 40	40 / 40 / 40
Oil charge per Compressor, oz (g)	213 (6299)	213 (6299)	213 (6299)	213 (6299)	213 (6299)	213 (6299)	213 (6299)	213 (6299)
	213 (6299)	213 (6299)	213 (6299)	213 (6299)	213 (6299)	213 (6299)	213 (6299)	213 (6299)
	213 (6299)	213 (6299)	213 (6299)	213 (6299)	213 (6299)	213 (6299)	213 (6299)	213 (6299)
Staging, 6 Stages (If Circuit is in Lead)	0-16-32-47-68-84-100	0-16-32-53-68-84-100	0-15-30-50-70-85-100	0-15-30-50-70-85-100	0-14-33-52-67-81-100	0-19-33-48-67-86-100	0-17-33-50-67-83-100	0-17-33-50-67-83-100
<b>CONDENSER, MICROCHANNEL</b>								
Coil Inlet Face Area, sq. ft. (sq. m.)	158.9 (14.8)	158.9 (14.8)	158.9 (14.8)	158.9 (14.8)	185.4 (17.3)	185.4 (17.3)	185.4 (17.3)	185.4 (17.3)
Rows Deep/Fins Per Inch	1 / 21	1 / 21	1 / 21	1 / 21	1 / 21	1 / 21	1 / 21	1 / 21
<b>CONDENSER FANS, DIRECT DRIVE PROPELLER</b>								
# of Fans per Circuit - Fan Diameter in. (mm)	6 - 30 (762)	6 - 30 (762)	6 - 30 (762)	6 - 30 (762)	7 - 30 (762)	7 - 30 (762)	7 - 30 (762)	7 - 30 (762)
Fan Motor, hp (kW)	2.0 (1.5)		2.0 (1.5)		2.0 (1.5)		2.0 (1.5)	
Fan & Motor RPM (for all 60Hz) <sup>1</sup>	1140		1140		1140		1140	
Airflow, cfm (l/s) <sup>1</sup>	135480 (63940)		135480 (63940)		158060 (74597)		158060 (74597)	
<b>EVAPORATOR, BRAZED PLATE<sup>3</sup></b>								
Dry Weight lbs (kg)	670 (304)		670 (304)		806 (366)		806 (366)	
Water Volume, gallons (liters)	17.95 (68)		17.95 (68)		22.44 (85)		22.44 (85)	
Grooved inlet/outlet connection, in. (mm) <sup>2</sup>	5.0 (127)		5.0 (127)		5.0 (127)		5.0 (127)	
Max. Water Pressure, psi (kPa)	435 (3000)		435 (3000)		435 (3000)		435 (3000)	
Max. Refrigerant Pressure, psi (kPa)	652 (4496)		652 (4496)		652 (4496)		652 (4496)	

**NOTE:** 1) **All Models:** Fan RPM = 950 for 400V/50Hz. Airflow = (0.83 x 60Hz Airflow) for 400V/50Hz.  
 2) Water connection shown is nominal pipe size.  
 3) Brazed plate evaporators do not have drain or vent connections integral to the heat exchanger. The connections must be installed in the field inlet and outlet piping as shown in Piping Section in the current version of the Installation and Operation Manual, available on [www.DaikinApplied.com](http://www.DaikinApplied.com).

Figure 33: AGZ030E - AGZ035E

334547101\_0B  
AGZ-E, 4 FANS

NOTE: LIFTING WEIGHTS ARE BASED ON UNIT SHIPPING WEIGHTS.  
MOUNTING WEIGHTS ARE BASED ON UNIT OPERATING WEIGHT WITH EVAPORATOR WATER INCLUDED.  
SHIPPING AND OPERATING WEIGHTS DO NOT INCLUDE THE WEIGHTS OF ANY OPTIONS OR ACCESSORIES.

PACKAGE UNITS WITH MICROCHANNEL COILS		
UNIT MODEL	X	Z
AGZ030E	38.9 (988)	40.9 (1039)
AGZ035E	39.7 (1008)	38.1 (968)

PACKAGE UNITS WITH MICROCHANNEL COILS		
UNIT MODEL	CG LOCATION, IN. (MM)	
	X	Y
AGZ030E	44.5 (1130)	40.9 (1039)
AGZ035E	45.5 (1156)	38.1 (968)

PACKAGE UNITS WITH MICROCHANNEL COILS		
UNIT MODEL	EVAP. DIMENSIONS IN. (MM)	CONNECTION SIZE (VICTAULIC)
	A	B
AGZ030E	24.2 (615)	2.9 (74)
AGZ035E	23.5 (597)	2.2 (56)

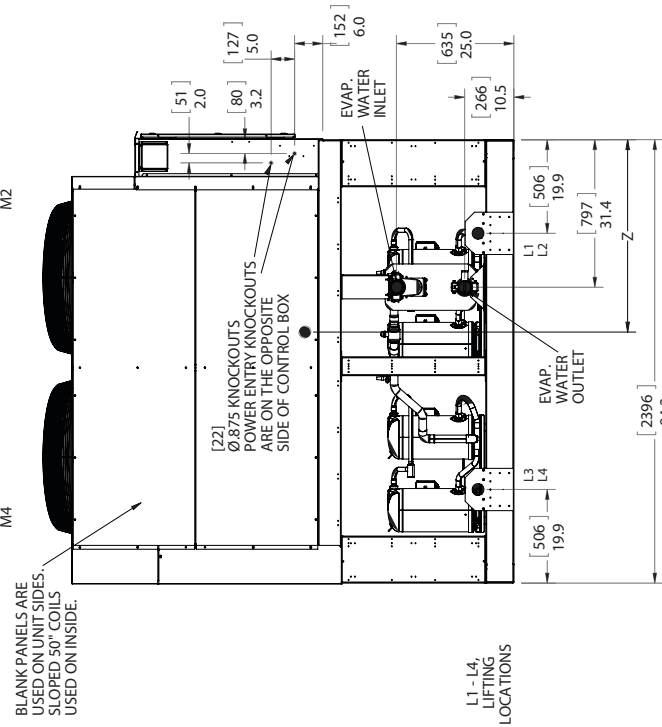
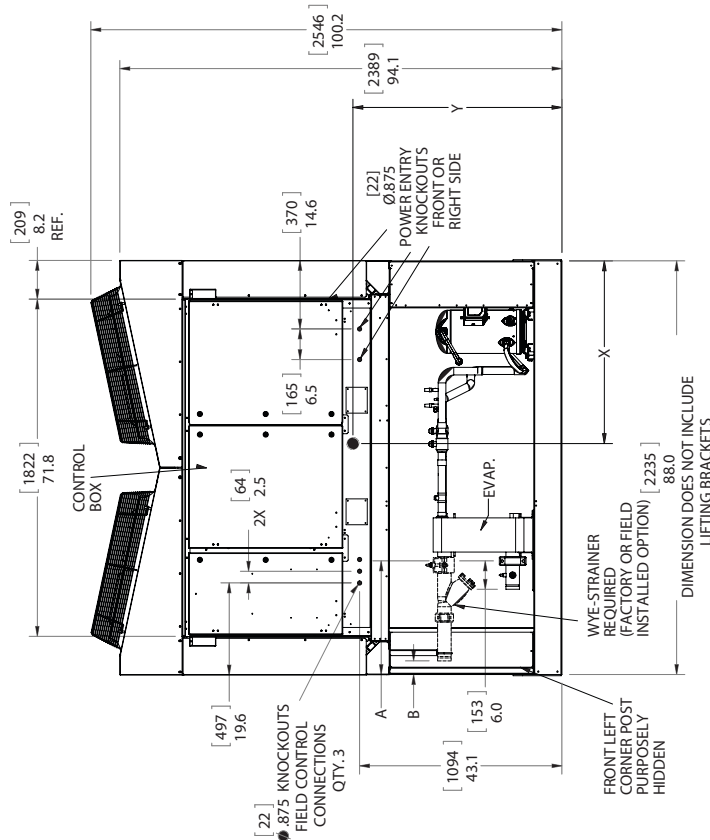
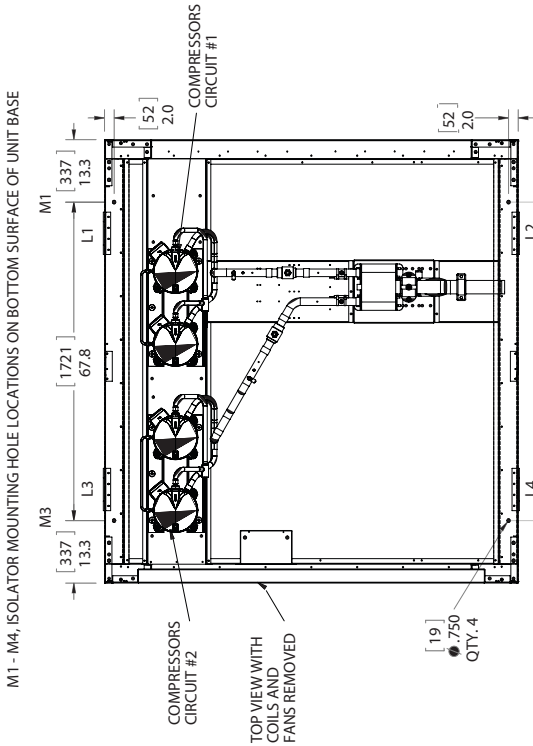

UNIT MODEL	PACKAGE UNITS WITH MICROCHANNEL COILS				PACKAGE UNITS WITH MICROCHANNEL COILS				
	SHIPPING WEIGHT		LIFTING (SHIPPING) WEIGHT BY CORNER LBS (KG)		OPERATING WEIGHT		MOUNTING (OPERATING) WEIGHT LBS (KG)		
	LBS (KG)	L1	L2	L3	L4	M1	M2	M3	M4
AGZ030E	2947 (1337)	1011 (459)	799 (362)	635 (288)	502 (228)	980 (445)	775 (352)	673 (305)	532 (241)
AGZ035E	2873 (1303)	1051 (477)	861 (391)	528 (240)	433 (196)	1005 (456)	824 (374)	581 (264)	476 (216)

Figure 34: AGZ040E - AGZ070E

PACKAGE UNITS WITH MICROCHANNEL COILS			
UNIT MODEL	CG LOCATION, IN. (MM)		
	X	Y	Z
AGZ040E	39.8 (1011)	45.9 (1166)	38.4 (975)
AGZ045E	38.9 (988)	44.5 (1130)	41.2 (1047)
AGZ050E	39.1 (993)	44.9 (1141)	41.2 (1047)
AGZ055E	39.1 (993)	44.8 (1138)	41.2 (1047)
AGZ060E	39.2 (996)	44.6 (1133)	41.1 (1044)
AGZ065E	39.2 (996)	44.6 (1133)	41.1 (1044)
AGZ070E	36.8 (935)	41.8 (1062)	42.6 (1082)

UNIT MODEL	EVAP. DIMENSIONS IN. (MM)			CONNECTION SIZE (VICTAULIC)
	A	B		
AGZ040E	22.8 (579)	1.5 (38)		2.5 (64)
AGZ045E	21.4 (544)	0.11 (3)		2.5 (64)
AGZ050E	20 (508)	2.7 (69)		2.5 (64)
AGZ055E	19.3 (490)	2.0 (51)		2.5 (64)
AGZ060E	17.6 (447)	0.3 (8)		2.5 (64)
AGZ065E	17.6 (447)	0.3 (8)		2.5 (64)
AGZ070E	17.6 (447)	0.3 (8)		2.5 (64)

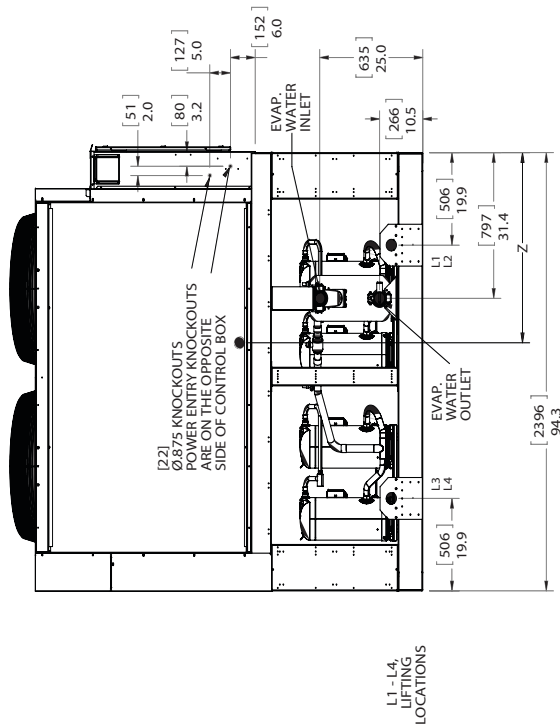
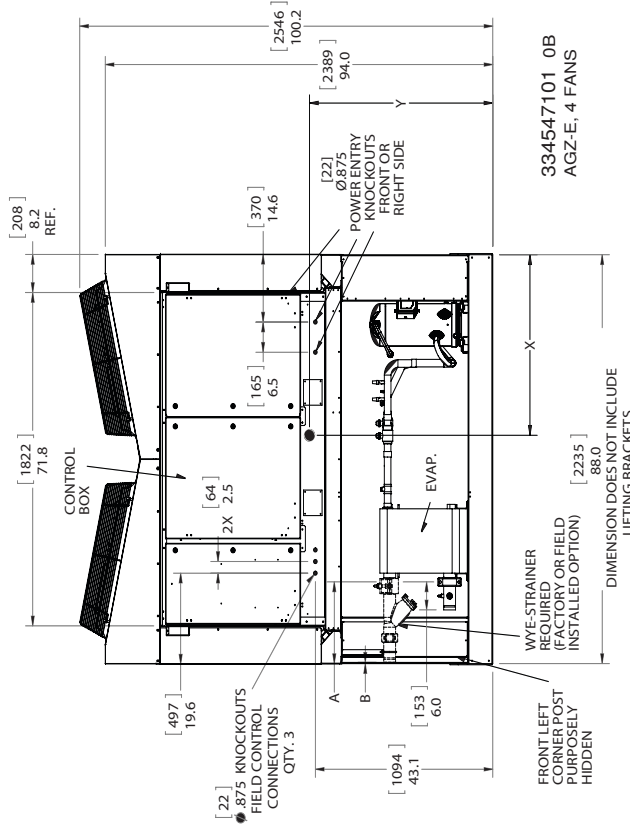
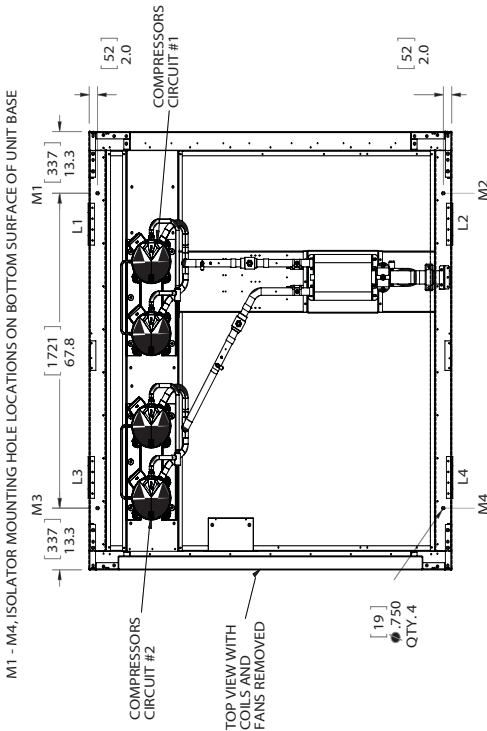

UNIT MODEL	PACKAGE UNITS WITH MICROCHANNEL COILS							
	LIFTING (SHIPPING) WEIGHT BY CORNER LBS (KG)		MOUNTING (OPERATING) WEIGHT LBS (KG)					
	L1	L2	L3	L4	M1	M2	M3	M4
AGZ040E	1067 (484)	881 (400)	548 (249)	453 (206)	1022 (464)	844 (383)	601 (273)	496 (225)
AGZ045E	1051 (477)	832 (377)	676 (307)	535 (243)	1021 (463)	809 (367)	715 (324)	567 (257)
AGZ050E	1049 (476)	837 (380)	671 (304)	536 (243)	1020 (463)	814 (369)	712 (323)	568 (258)
AGZ055E	1052 (477)	840 (381)	675 (306)	539 (245)	1023 (464)	817 (371)	716 (325)	572 (260)
AGZ060E	1059 (480)	851 (386)	676 (307)	543 (246)	1031 (468)	828 (376)	718 (326)	577 (262)
AGZ065E	1059 (480)	851 (386)	676 (307)	543 (246)	1031 (468)	828 (376)	718 (326)	577 (262)
AGZ070E	1180 (535)	847 (384)	842 (382)	604 (274)	1157 (525)	830 (377)	880 (399)	631 (286)

NOTE: LIFTING WEIGHTS ARE BASED ON UNIT SHIPPING WEIGHTS.  
 MOUNTING WEIGHTS, BASED ON UNIT OPERATING WEIGHT WITH EVAPORATOR WATER INCLUDED.  
 SHIPPING AND OPERATING WEIGHTS DO NOT INCLUDE THE WEIGHTS OF ANY OPTIONS OR ACCESSORIES.

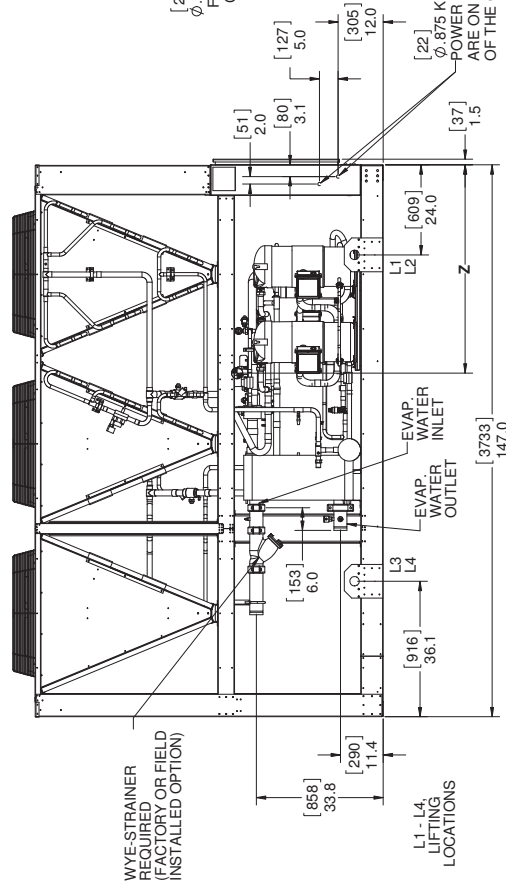
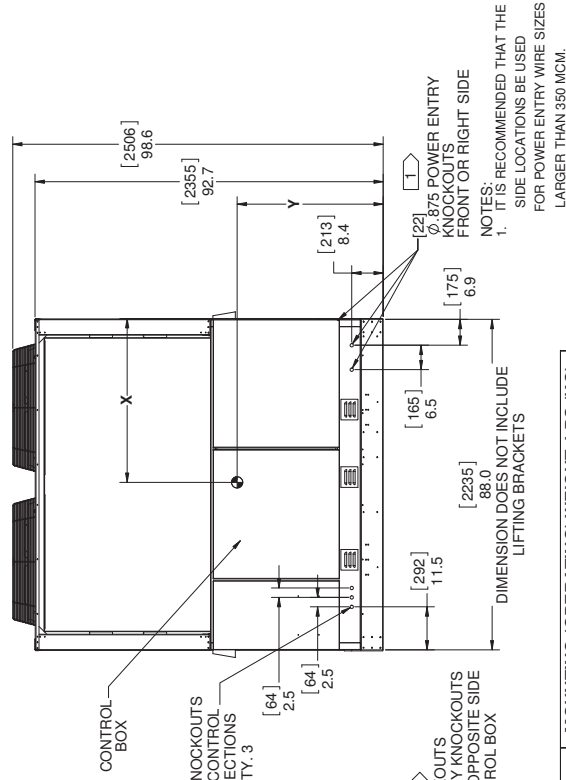
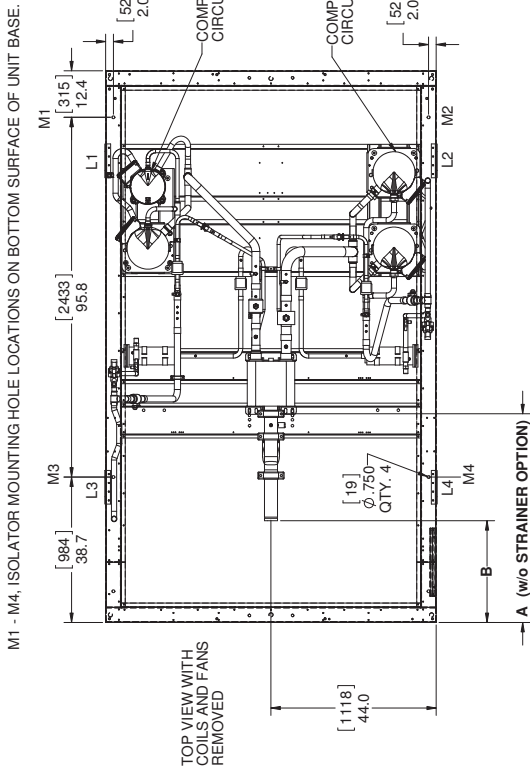

Figure 35: AGZ075E - AGZ101E

AGZ-E, 6 FANS  
334547111 D 0A

UNIT MODEL	CG LOCATION, IN. (MM)			EVAP. DIMENSIONS IN. (MM)		CONNECTION SIZE, IN.
	X	Y	Z	A	B	
AGZ075076E	45.3 (1151)	38.6 (980)	56.2 (1427)	55.6 (1412)	27.1 (688)	3.0 (76)
AGZ080081E	44.2 (1122)	39.2 (995)	56.5 (1435)	54.4 (1382)	25.9 (658)	
AGZ090091E	44.2 (1122)	39.2 (995)	55.0 (1397)	54.4 (1382)	25.9 (658)	
AGZ100101E	43.6 (1108)	38.9 (988)	55.7 (1415)	51.6 (1311)	23.1 (587)	

NOTE: LIFTING WEIGHTS ARE BASED ON UNIT SHIPPING WEIGHTS. MOUNTING WEIGHTS ARE BASED ON UNIT OPERATING WEIGHT WITH EVAPORATOR WATER INCLUDED. SHIPPING AND OPERATING WEIGHTS DO NOT INCLUDE THE WEIGHTS OF ANY OPTIONS OR ACCESSORIES.



UNIT MODEL	SHIPPING WEIGHT				OPERATING WEIGHT				LIFTING (SHIPPING) WEIGHT BY CORNER				MOUNTING (OPERATING) WEIGHT, LBS (KG)				
	LBS (KG)	L1	L2	L3	LBS (KG)	L1	L2	L3	L4	M1	M2	M3	M4	LBS (KG)	LBS (KG)	LBS (KG)	LBS (KG)
AGZ075076E	4388 (1990)	1341 (608)	1420 (644)	790 (358)	837 (380)	1173 (532)	1242 (563)	989 (449)	1047 (475)	1173 (532)	1242 (563)	989 (449)	1047 (475)	989 (449)	1047 (475)	1047 (475)	1047 (475)
AGZ080081E	4510 (2046)	1407 (638)	1418 (643)	840 (381)	846 (384)	1232 (559)	1241 (563)	1049 (476)	1057 (479)	1232 (559)	1241 (563)	1049 (476)	1057 (479)	1049 (476)	1057 (479)	1057 (479)	1057 (479)
AGZ090091E	4540 (2059)	1456 (660)	1466 (665)	806 (366)	812 (368)	1276 (579)	1285 (583)	1020 (463)	1028 (466)	1276 (579)	1285 (583)	1020 (463)	1028 (466)	1028 (466)	1028 (466)	1028 (466)	1028 (466)
AGZ100101E	4696 (2130)	1505 (683)	1480 (671)	863 (391)	848 (385)	1322 (600)	1299 (589)	1089 (494)	1070 (485)	1322 (600)	1299 (589)	1089 (494)	1070 (485)	1089 (494)	1070 (485)	1070 (485)	1070 (485)

Figure 36: AGZ110E - AGZ130E

AGZ-E 8 FANS  
334547121 D 0A

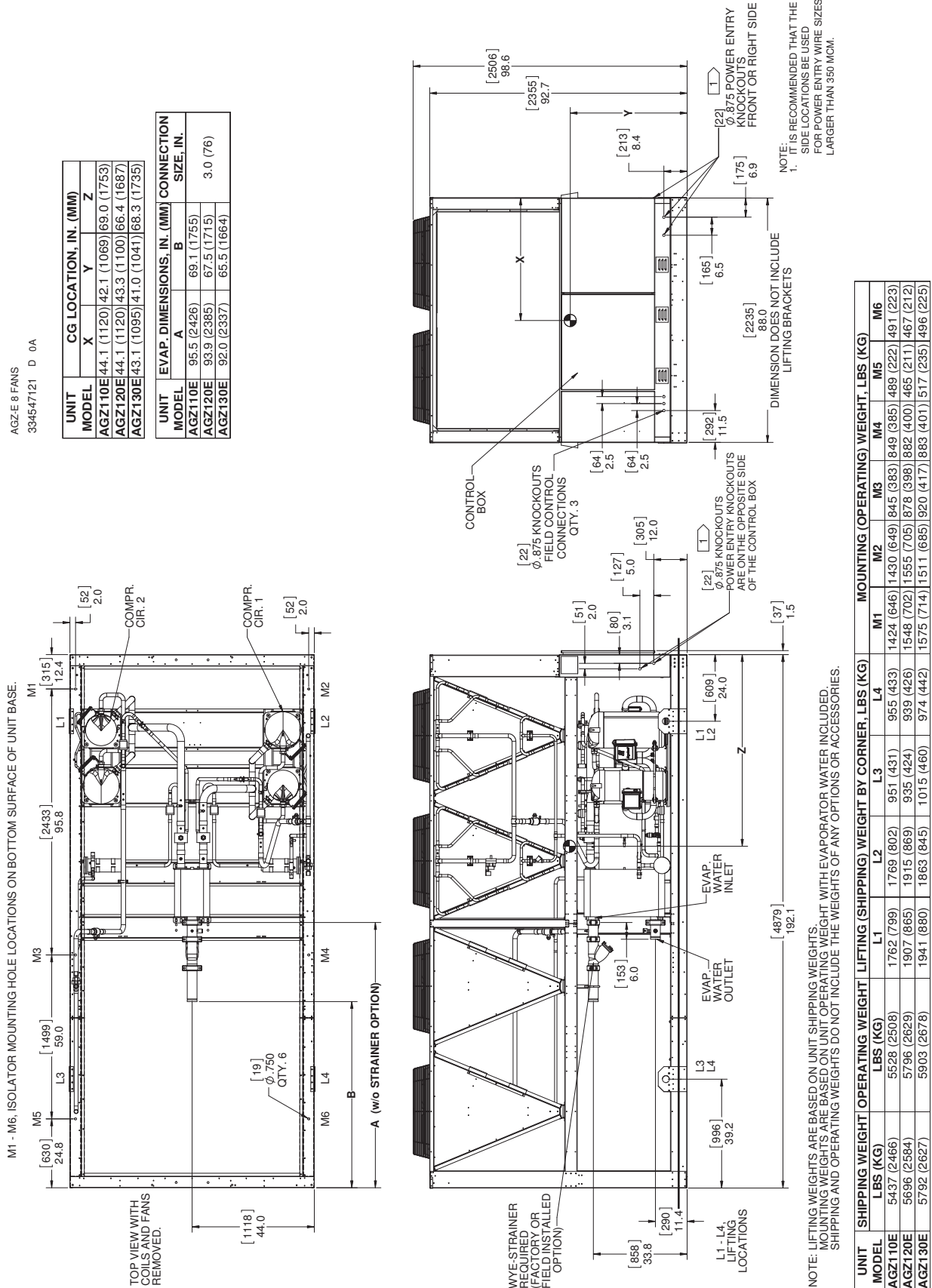
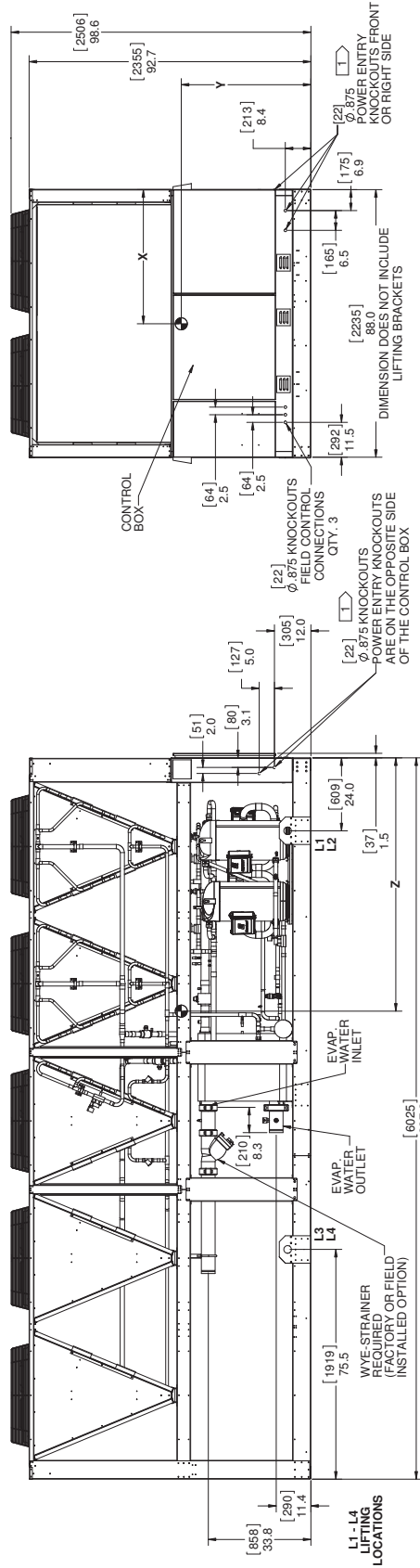
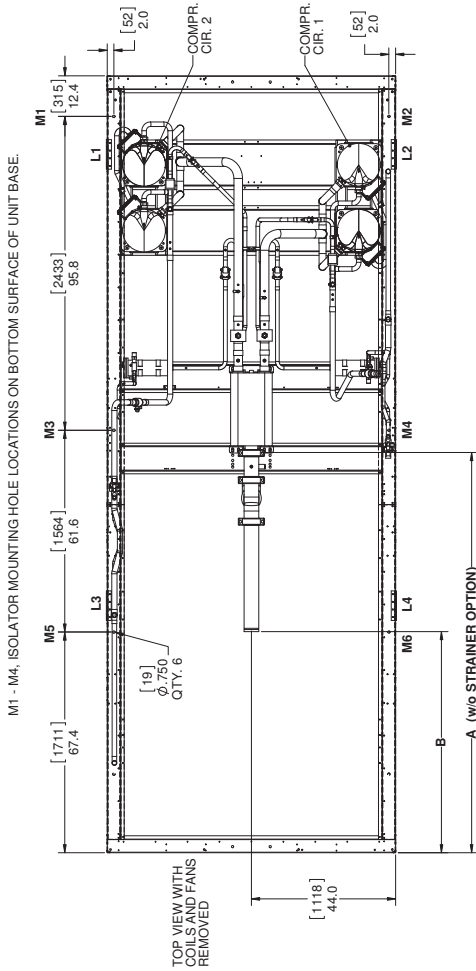

Figure 37: AGZ140E - AGZ161E

AGZ-E 10FANS, 4 COMPRESSORS.  
334547131 D 08

UNIT MODEL	X	Y	Z	A	B	CONNECTION SIZE, IN.
AGZ140E	44.1 (1120)	42.6 (1083)	83.3 (2117)	122.1 (3102)	67.51 (1715)	4.0 (102)
AGZ150E	43.9 (1116)	42.4 (1077)	83.3 (2115)	120.5 (3062)	65.9 (1674)	4.0 (102)
AGZ161E	43.5 (1105)	42.3 (1074)	83.4 (2117)	120.5 (3062)	65.9 (1674)	4.0 (102)

NOTE:  
1. IT IS RECOMMENDED THAT THE SIDE LOCATIONS BE USED FOR MOUNTING. LIFTING WEIGHTS ARE BASED ON UNIT SHIPPING WEIGHTS. MOUNTING WEIGHTS ARE BASED ON UNIT OPERATING WEIGHTS. WEIGHTS FOR ACCESSORIES, INCLUDING LIFTING BRACKETS AND OPERATING WEIGHTS, DO NOT INCLUDE THE WEIGHTS OF ANY OPTIONS OR ACCESSORIES.



UNIT MODEL	L1	L2	L3	L4	M1	M2	M3	M4	M5	M6
AGZ140E	6555 (2973)	1862 (845)	1410 (640)	1415 (642)	1411 (640)	1416 (642)	1070 (485)	1074 (487)	850 (386)	853 (387)
AGZ150E	6617 (3001)	1888 (856)	1426 (647)	1421 (645)	1433 (650)	1428 (648)	1085 (492)	1081 (490)	861 (391)	858 (389)
AGZ161E	6668 (3025)	1917 (870)	1876 (851)	1453 (659)	1422 (645)	1425 (646)	1104 (501)	1080 (490)	878 (398)	859 (390)

Figure 38: AGZ170E - AGZ180E

AGZE 10FANS, 6 COMPRESSORS.  
339457131 D 08

UNIT MODEL	CG LOCATION, IN. (MM)			EVAP. DIMENSIONS, IN. (MM)			CONNECTION SIZE, IN.
	X	Y	Z	A	B		
AGZ170E	43.2 (1096)	40.4 (1025)	83.6 (2123)	119 (3022)	64.3 (1634)		4.0 (102)
AGZ180E	44.1 (1119)	39.4 (1000)	82.8 (2109)	117 (2971)	62.4 (1584)		

NOTE: IT IS RECOMMENDED THAT THE SIDE LOCATIONS BE USED FOR POWER ENTRY WIRE SIZES LARGER THAN 350 MCM.

NOTE: LIFTING WEIGHTS ARE BASED ON UNIT SHIPPING WEIGHTS. MOUNTING WEIGHTS ARE BASED ON UNIT OPERATING WEIGHTS. LIFTING WEIGHTS DO NOT INCLUDE THE WEIGHTS OF ANY OPTIONS OR ACCESSORIES.

62.4 (1584)

M1 - M4, ISOLATOR MOUNTING HOLE LOCATIONS ON BOTTOM SURFACE OF UNIT BASE.

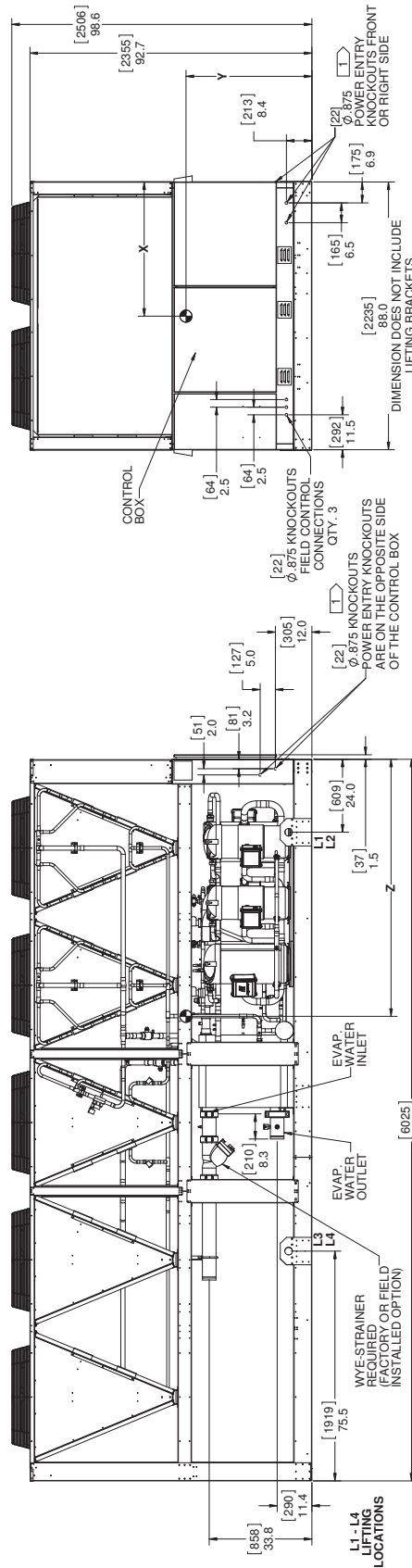
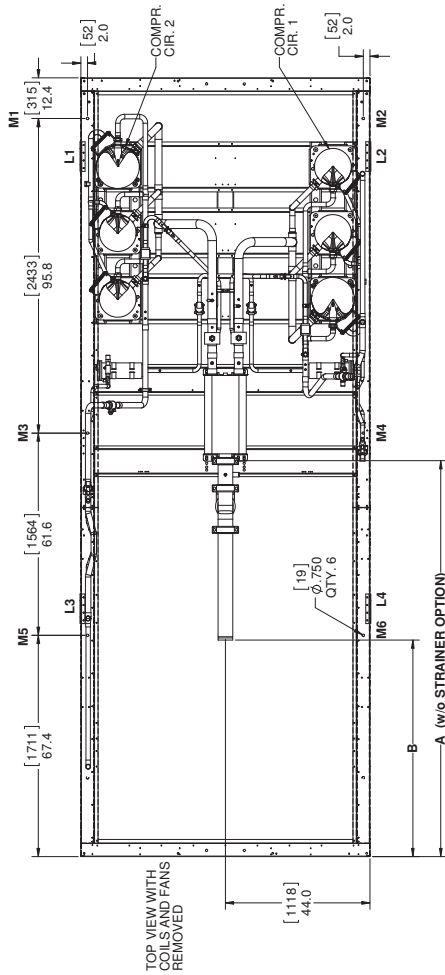

UNIT MODEL	SHIPPING WEIGHT OPERATING WEIGHT			LIFTING (SHIPPING) WEIGHT BY CORNER, LBS (KG)			MOUNTING (OPERATING) WEIGHT, LBS (KG)						
	LBS (KG)	LBS (KG)		L1	L2	L3	L4	M1	M2	M3	M4	M5	M6
AGZ170E	7170 (3252)	7307 (3314)	7560 (3429)	2072 (940)	1995 (905)	1581 (717)	1522 (690)	1571 (713)	1512 (686)	1197 (543)	1152 (523)	956 (434)	920 (417)
AGZ180E	7412 (3362)	7560 (3429)	7560 (3429)	2121 (962)	2127 (965)	1580 (717)	1584 (718)	1613 (732)	1617 (733)	1210 (549)	1214 (551)	951 (431)	954 (433)

Figure 39: AGZ191E - AGZ211E

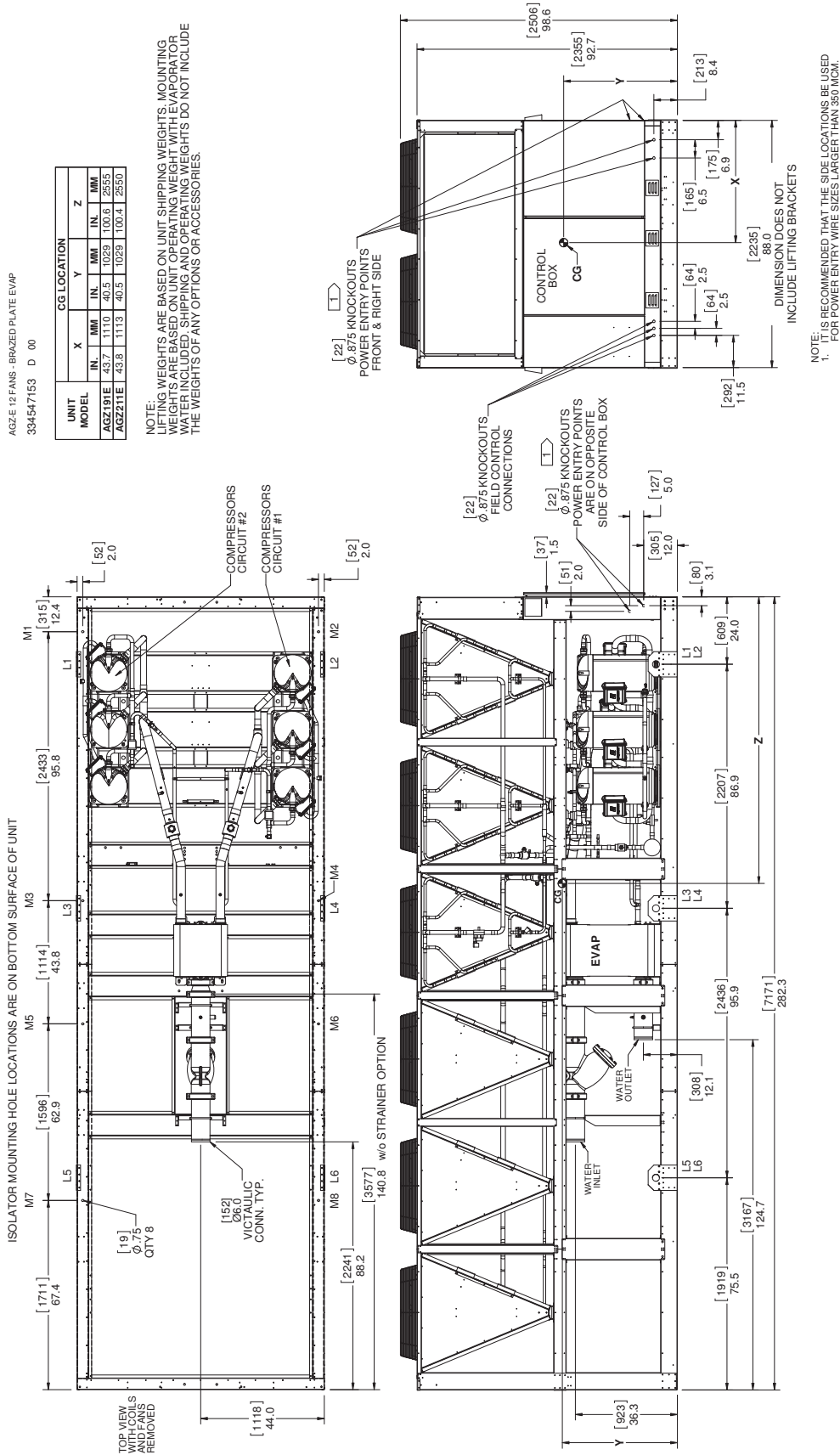

UNIT MODEL	SHIP WEIGHT		LIFTING (SHIPPING) WEIGHT BY CORNER								MOUNTING (OPERATING) WEIGHT																					
	LBS	KG	L1	L2	L3	L4	L5	L6	M1	M2	M3	M4	M5	M6	M7	M8																
AGZ191E	8635	3917	8785	3985	1759	798	1738	788	1458	661	1441	654	1127	511	1113	505	1578	716	1560	708	1164	528	1150	522	974	442	963	437	702	318	694	315
AGZ211E	8669	3932	8819	4000	1766	801	1753	795	1461	663	1450	658	1124	510	1116	506	1585	719	1573	713	1166	529	1158	525	975	442	968	439	700	318	695	315

Figure 40: AGZ226E - AGZ241E

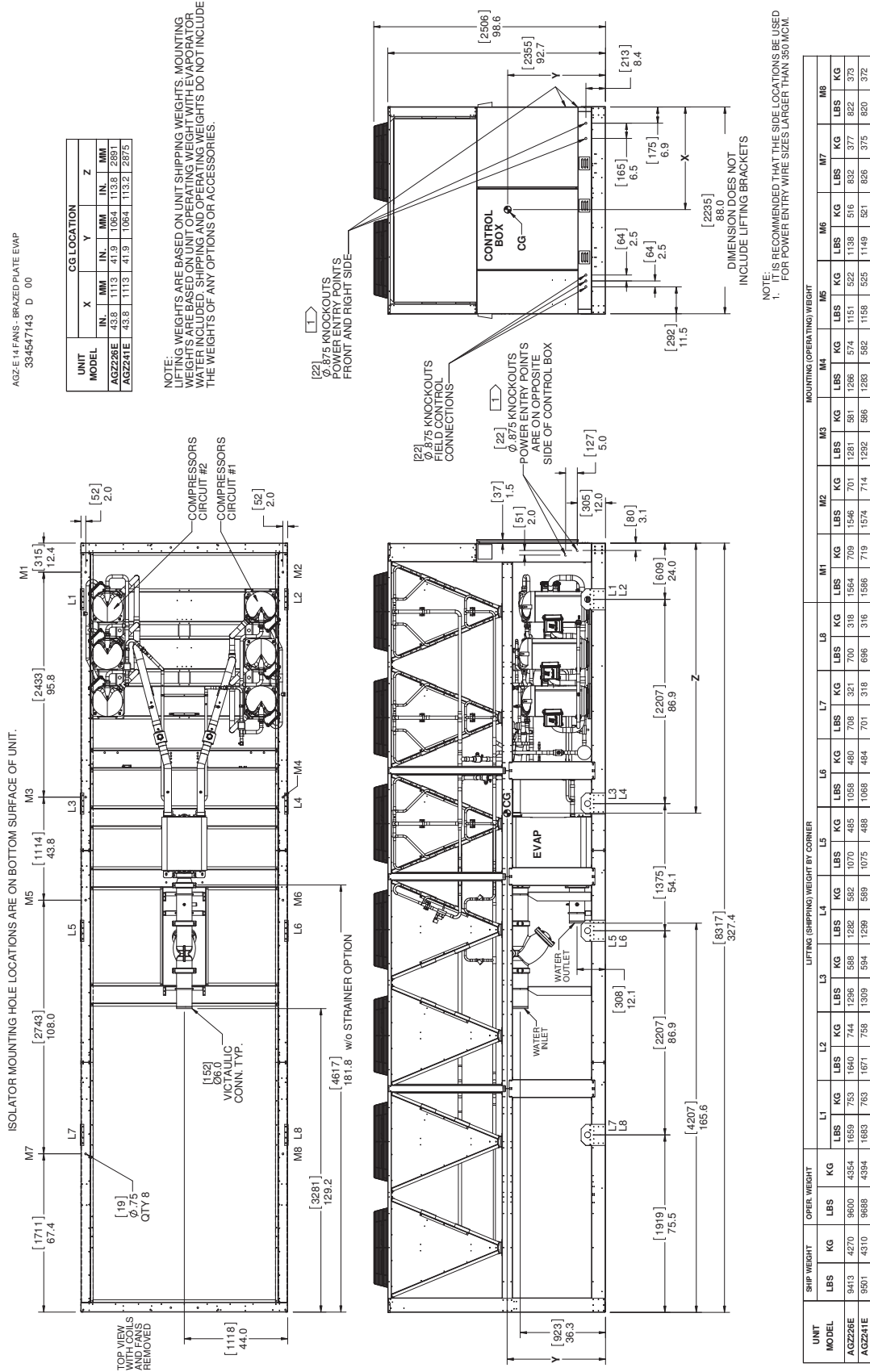
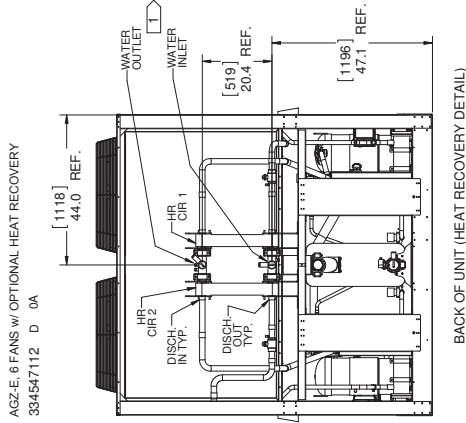



Figure 41: AGZ075E - AGZ101E - Heat Recovery Option



AGZ\_E\_6 FANS w/ OPTIONAL HEAT RECOVERY  
334547112 D\_0A

UNIT MODEL	CG LOCATION			Z
	X	Y		
AGZ075076E	45.5	1156	39.0	991
AGZ080081E	44.5	1130	39.5	1003
AGZ090091E	44.5	1130	39.5	1003
AGZ100101E	44.0	1118	39.3	998

  

UNIT MODEL	EVAP DIM'S			NOM. VICTAULIC CONN. SIZE		
	A	B		IN.	MM	IN.
AGZ075076E	55.6	1412	27.1	688		
AGZ080081E	54.4	1382	25.9	658	3.0	76
AGZ090091E	54.4	1382	25.9	658		
AGZ100101E	51.6	1311	23.1	587		

NOTE:  
1. HEAT RECOVERY WATER CONNECTIONS FOR CIRCUIT 1 & 2 ARE CONNECTED WITH A TEE AND HAVE ONE INLET & ONE OUTLET. CONNECTION SIZES ARE 2.0 NOMINAL VICTAULIC. IT IS RECOMMENDED THAT THE SIDE LOCATIONS BE AT LEAST 350 MCH.  
2. THE POWER ENTRY WIRE SIZES LARGER THAN 350 MCH.

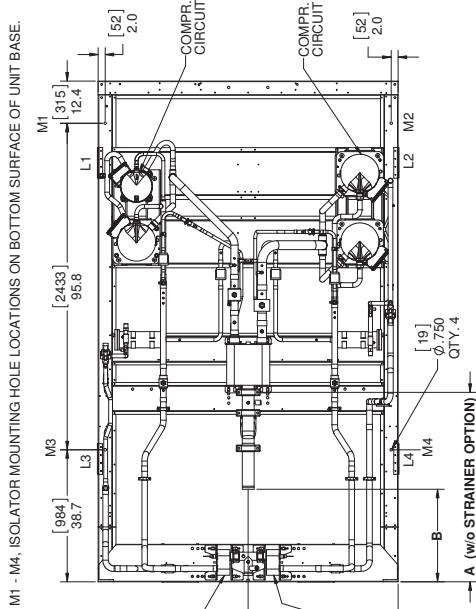

M1 - M4, ISOLATOR MOUNTING HOLE LOCATIONS ON BOTTOM SURFACE OF UNIT BASE.

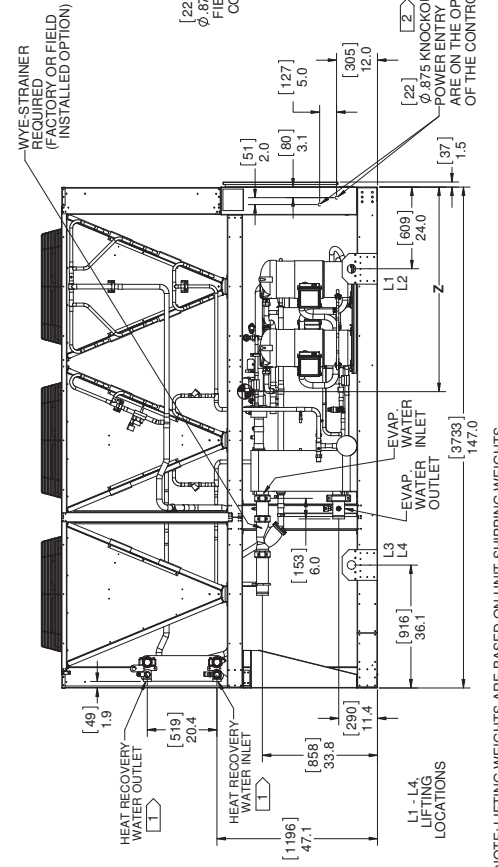
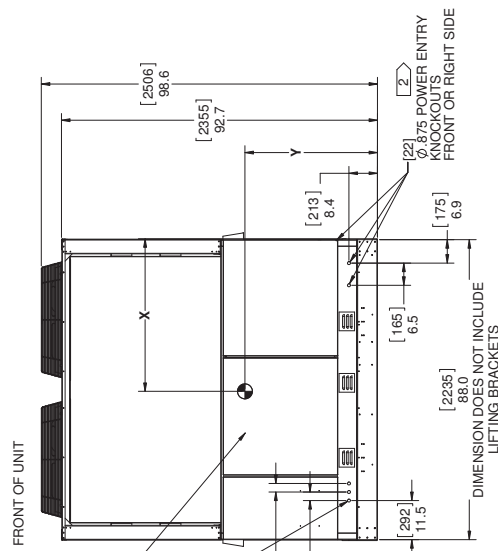

NOTE: LIFTING WEIGHTS ARE BASED ON UNIT SHIPPING WEIGHTS. MOUNTING WEIGHTS ARE BASED ON UNIT OPERATING WEIGHT WITH EVAPORATOR & HEAT RECOVERY WATER INCLUDED. SHIPPING AND OPERATING WEIGHTS WITH HEAT RECOVERY DO NOT INCLUDE THE WEIGHTS OF ANY OTHER OPTIONS OR ACCESSORIES.

UNIT MODEL	SHIP WEIGHT		LIFTING (SHIPPING) WEIGHT BY CORNER				MOUNTING (OPERATING) WEIGHT											
	LBS	KG	L1	L2	L3	L4	M1	M2	M3	M4								
AGZ075076E	4613	2092	1294	587	1388	630	932	423	1000	454	1129	512	1211	549	1134	514	1216	552
AGZ080081E	4794	2147	1285	587	1388	628	932	423	1000	454	1129	512	1211	549	1134	514	1216	552
AGZ090091E	4764	2161	1285	587	1388	628	932	423	1000	454	1129	512	1211	549	1134	514	1216	552
AGZ100101E	4936	2239	1452	659	1449	657	1019	461	1017	461	1273	577	1270	576	1250	567	1247	566

Figure 42: AGZ110E - AGZ130E - Heat Recovery Option

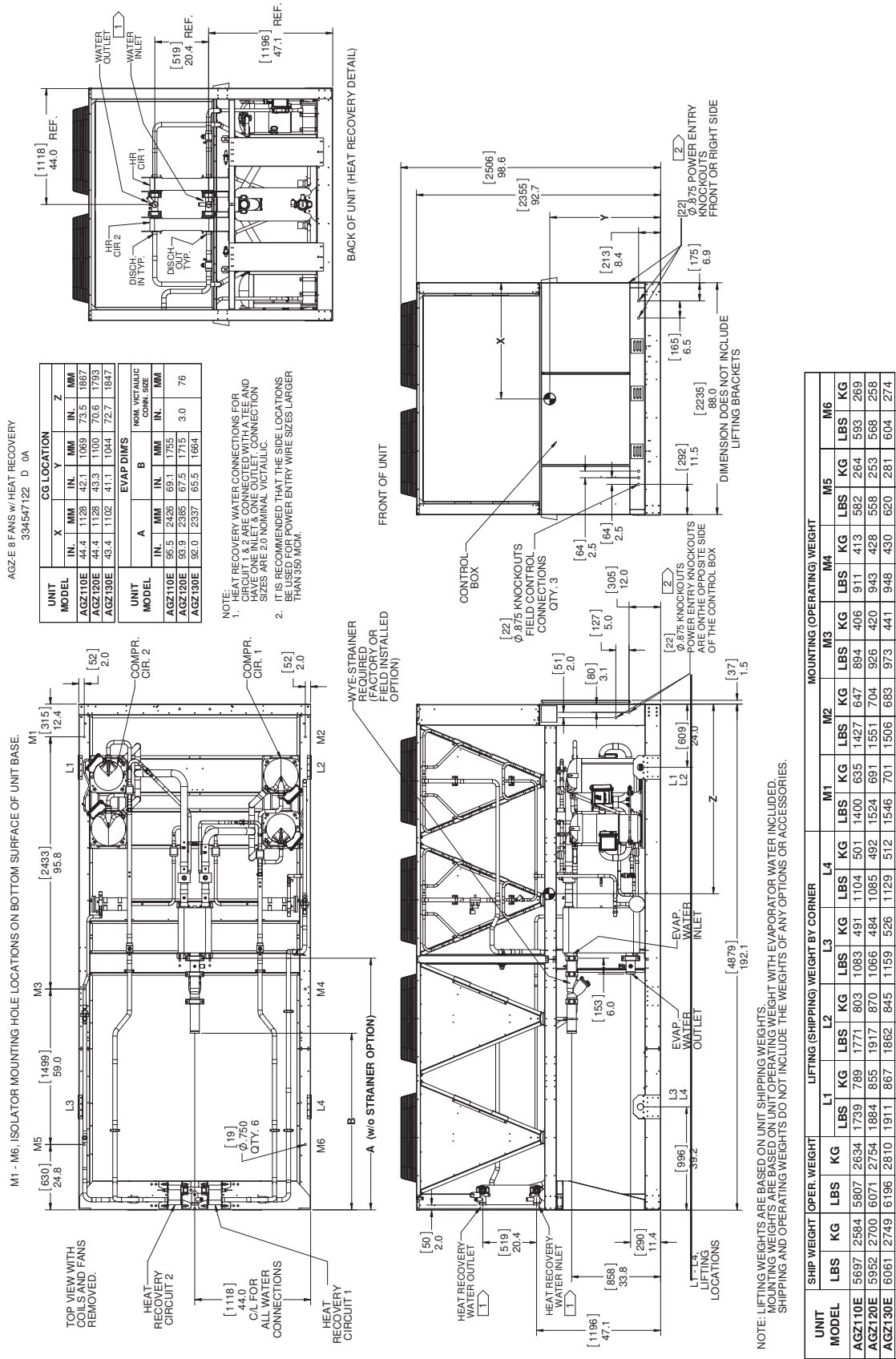





Figure 45: AGZ191E - AGZ211E - Heat Recovery Option

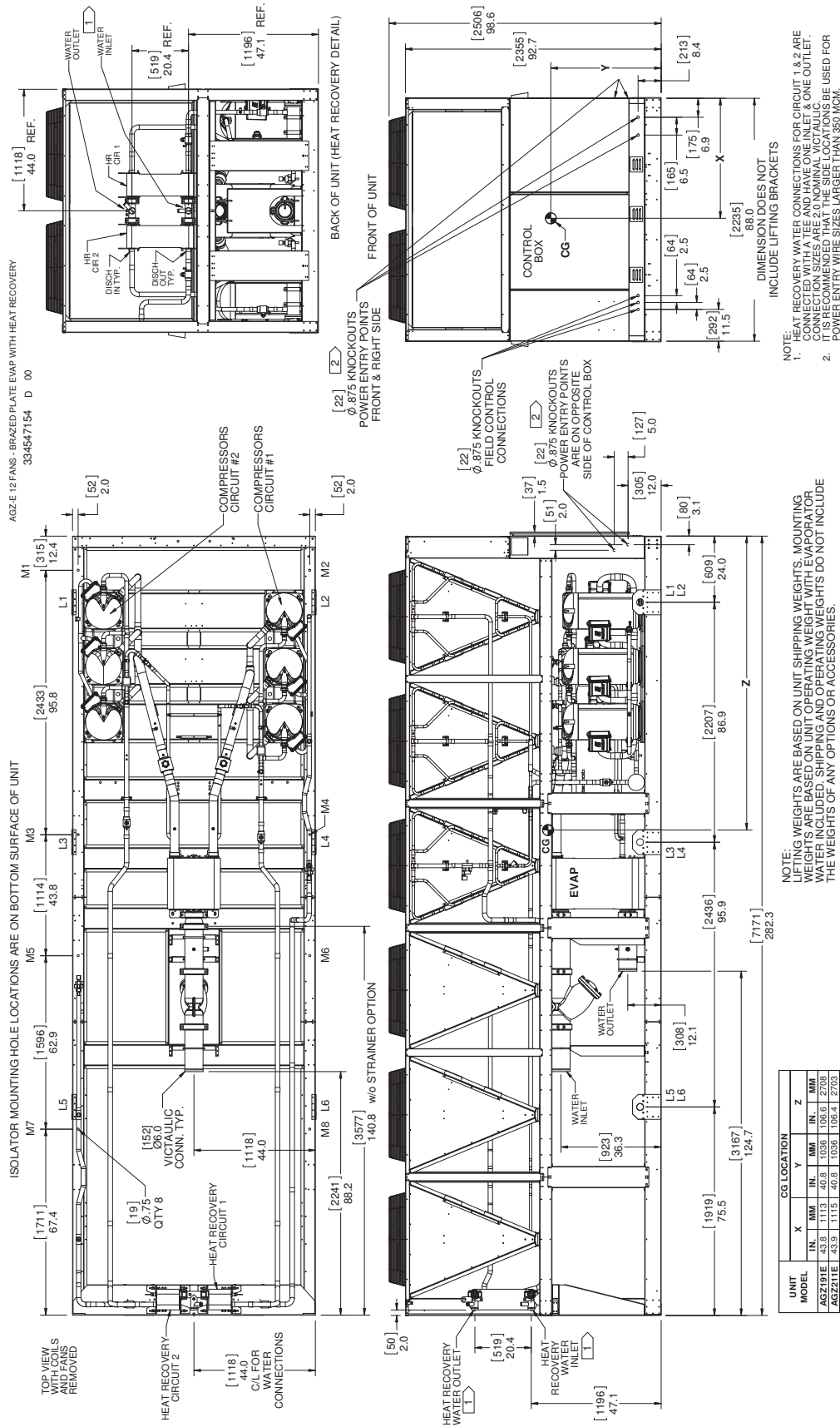
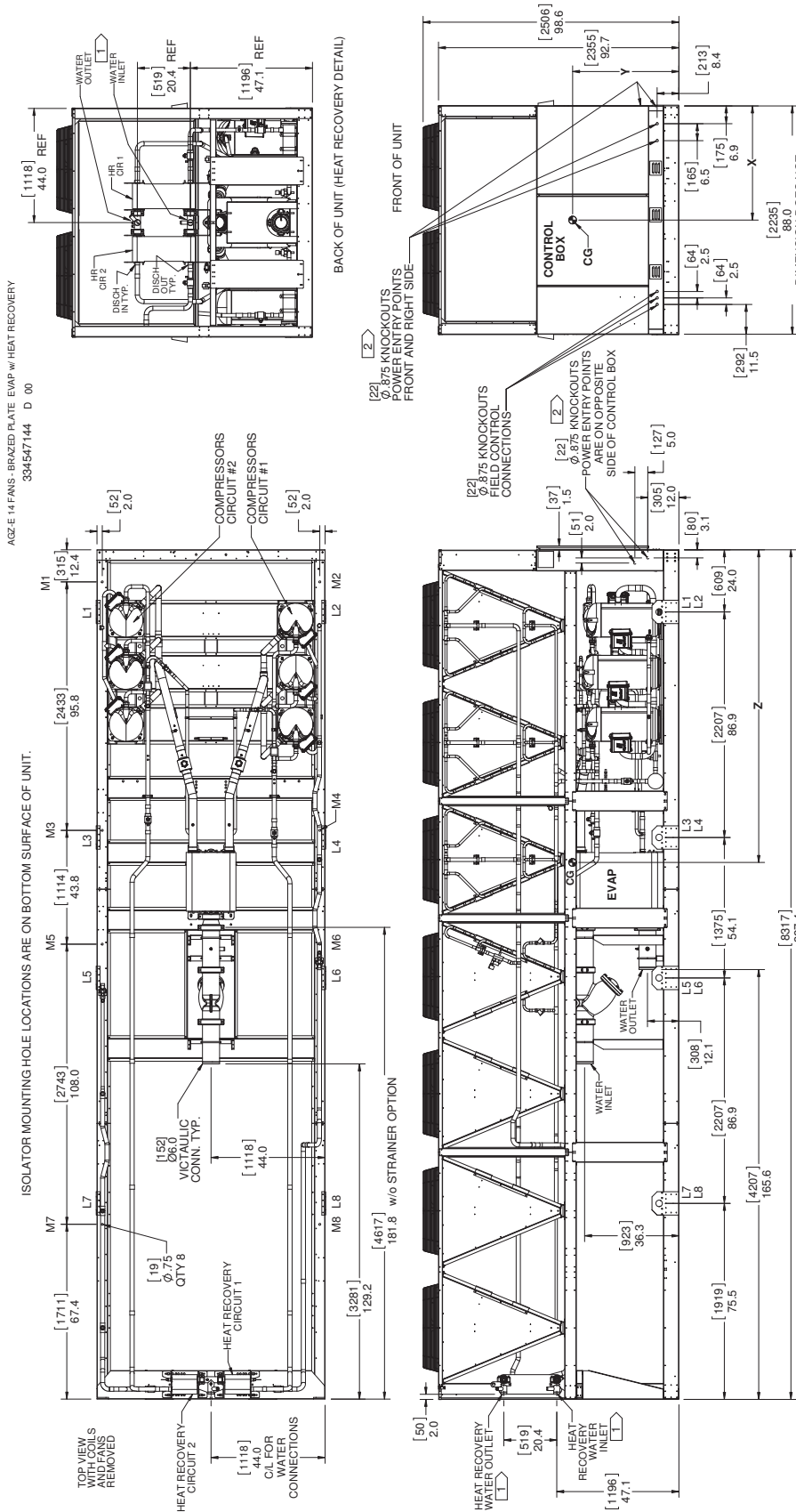



Figure 46: AGZ226E - AGZ241E - Heat Recovery Option



NOTE: HEAT RECOVERY WATER CONNECTIONS FOR CIRCUIT 1 & 2 ARE CONNECTED WITH A TEE AND HAVE ONE INLET & ONE OUTLET. CONNECTION SIZES ARE 2.0 NOMINAL VICTAULIC. IT IS RECOMMENDED THAT THE SIDE LOCK NUTS BE USED FOR POWER ENTRY WIRE SIZES LARGER THAN #80 INCH.

NOTE: WEIGHTS ARE BASED ON UNIT SHIPPING WEIGHTS. MOUNTING LIFTING ARE BASED ON UNIT OPERATING WEIGHT WITH EVAPORATOR WATER INCLUDED. SHIPPING AND OPERATING WEIGHTS DO NOT INCLUDE THE WEIGHTS OF ANY OPTIONS OR ACCESSORIES.

UNIT MODEL	CG LOCATION		
	X	Y	Z
AGZ226E	43.9	111.5	42.1
AGZ241E	44.0	111.8	42.2

UNIT MODEL	SHIP WEIGHT								LIFTING (SHIPPING) WEIGHT BY CORNER								MOUNTING (OPERATING) WEIGHT																			
	LBS	KG	LBS	KG	LBS	KG	LBS	KG	L1	L2	L3	L4	L5	L6	L7	L8	M1	M2	M3	M4	M5	M6	M7	M8												
AGZ226E	9784	4438	10012	4541	1573	713	1563	709	1309	594	1301	590	1145	519	1138	516	881	400	875	397	1489	675	1479	671	1304	591	1295	587	1219	553	1211	549	1011	459	1004	455
AGZ241E	9973	4478	10101	4582	1597	724	1593	723	1321	599	1318	598	1150	522	1147	520	874	396	872	396	1511	685	1507	684	1315	596	1312	595	1226	556	1223	555	1005	456	1003	455



Figure 47: Spring Isolator

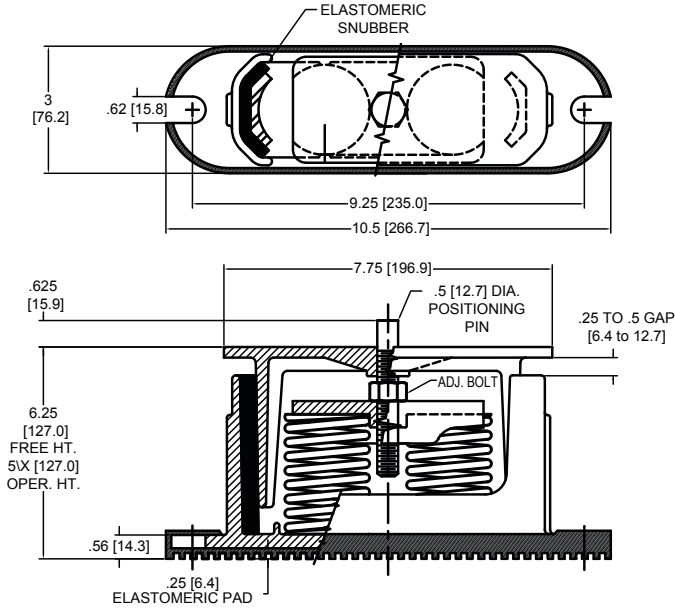

Transfer the unit as indicated in the current AGZ-E Installation and Operation Manual, which can be found on [www.DaikinApplied.com](http://www.DaikinApplied.com). In all cases, set the unit in place and level. If anti-skid pads are used, do not use hold down bolts. If hold down bolts are used, do not use anti-skid pads.

When spring isolators are required, install springs running under the main unit supports. Unit should be installed on blocks or shims at the listed free height. Isolator springs should not be loaded until the installation is complete, then adjust the springs to the vendor listed compression gap for the load point. When securing the isolator, do not over-tighten the mounting bolts. Over-tightening may result in cracking of the cast isolator housing and will have a negative impact on the isolation effect.

Installation of spring isolators requires flexible piping connections and at least three feet of flexible electrical conduit to avoid straining the piping and transmitting vibration and noise.

Mounting locations for each model can be found in the Dimensions and Weights section, starting on page 29.

Neoprene waffle pads, supplied by customers, should be mounted at the defined mounting point locations along the rail length.

Figure 48: Rubber-in-Shear (RIS) Isolator

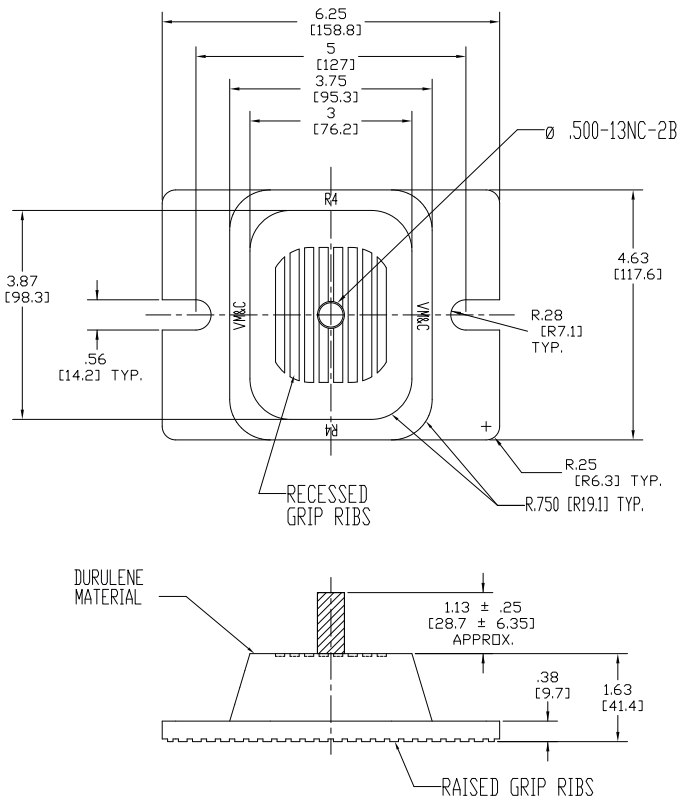

## Electrical Data Notes

1. Power wiring connections to the chiller may be done with either copper or aluminum wiring. Wire should be sized per NEC and/or local codes. Wire sizing and wire count must fit in the power connection lug sizing shown in the Electrical Data tables starting on [page 49](#).
2. Unit wire size ampacity (MCA) is equal to 125% of the largest compressor motor RLA, plus 100% of RLA of all other loads in the circuit.
3. Recommended fuse sizes are selected at approximately 175% of the largest compressor motor RLA, plus 100% of all other loads in the circuit.
4. Maximum fuse or breaker size is equal to 225% of the largest compressor motor RLA, plus 100% of all other loads.
5. The control transformer is furnished and no separate 115V power is required. For both single and multi-point power connections, the control transformer is in circuit #1 with control power wired from there to circuit #2. In multi-point power, disconnecting power to circuit #1 disconnects control power to the unit.
6. Wire sizing amps is 15 amps if a separate 115V power supply is used for the control circuit.
7. Single-point power supply requires a single disconnect to supply electrical power to the unit. This power supply must either be fused or use a circuit breaker.
8. All field wire lug range values given in the Electrical Data tables starting on [page 49](#) apply to 75°C rated wire per NEC.
9. Must be electrically grounded according to national and local electrical codes.

**⚠ DANGER**

Qualified, licensed electricians must perform wiring. Electrical shock hazard exists that can cause severe injury or death.

## Circuit Breakers

Factory-installed compressor circuit breakers are standard on units with single point power supply only. This option provides compressor short circuit protection and makes servicing easier.

## Voltage Limitations:

1. Within 10% of nameplate rating.
2. Voltage unbalance not to exceed 2% with a resultant current unbalance of 6 to 10 times the voltage unbalance per NEMA MG-1, 2009 Standard Rev. 1-2010.

**Table 24: Standard and HSCCR Panel Ratings**

Panel Type	208V / 230V	380V / 400V / 460V	575V
Standard	5kA	5kA	5kA
HSCCR	65kA	65kA	25kA

## Electrical Control Center

Operating and equipment protection controls and motor starting components are separately housed in a centrally located, weather-resistant control panel with hinged and tool-locked doors. In addition to the MicroTech® III controller described in the next sections, the following components are housed in the panel:

- Power terminal blocks, multi-point connection standard
- Control, input, and output terminal block
- Control transformer
- Optional disconnect switch (through-the-door handle)
- Compressor motor inherent thermal and overload protection is standard
- Optional phase voltage monitor with under/over voltage and phase reversal protection
- Fan contactors with short circuit protective devices.
- Optional ground fault protection
- FanTrol® fan staging head pressure control system
- Power connections are per [Table 25](#)

## Power Connections

**Table 25: Power Connection Availability**

Power Connection	Power Block	Disc. Swt.	Comp. Circuit Breakers	Panel High Short Circuit Current Rating
Optional Single Point	Std.	Opt.	Std.	Opt.
Standard Multi-Point	Std.	Opt.	Not Avail.	Not Avail.

## Definitions:

1. **Power Block:** An electrical device to directly accept field wiring without any disconnecting means.
2. **Disconnect Switch:** A molded case switch that accepts field wiring and disconnects main power to the entire unit or each main power supply if the multi-point power supply option is selected. This option does not provide overcurrent protection.
3. **Compressor Circuit Breakers:** A manually reset circuit breaker for each compressor, providing compressor only short circuit protection and located ahead of the contactor.
4. **Control Panel High Short Circuit Current Rating:** (Previously known as “withstand rating”). The entire control panel is designed for short circuit current rating as shown in [Table 24](#). In the event of a short circuit, the damage is contained within the control panel enclosure.

Figure 49: Typical Field Wiring Diagram (Single-Point Connection)

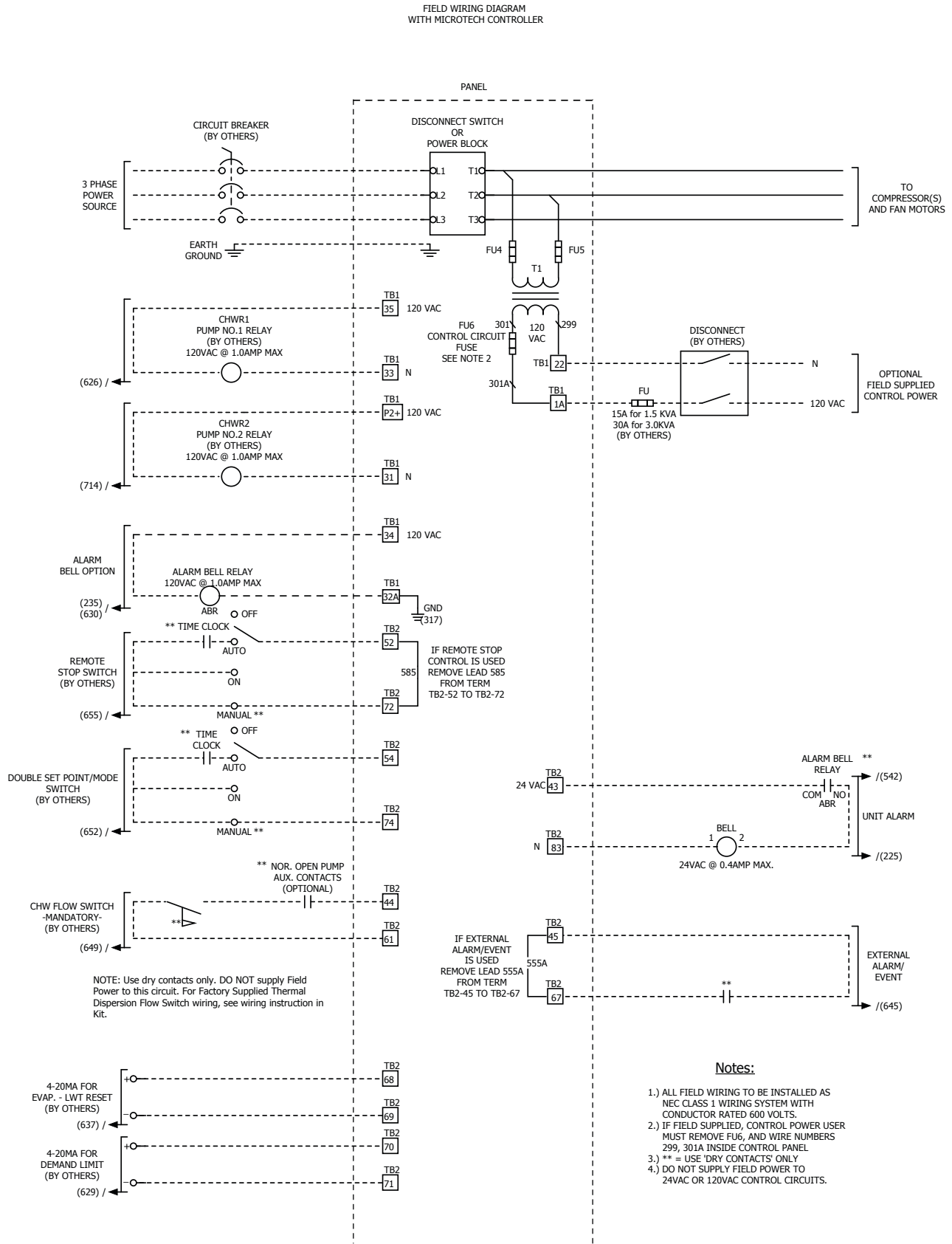

Figure 50: Typical Field Wiring Diagram (Multi-Point Connection)

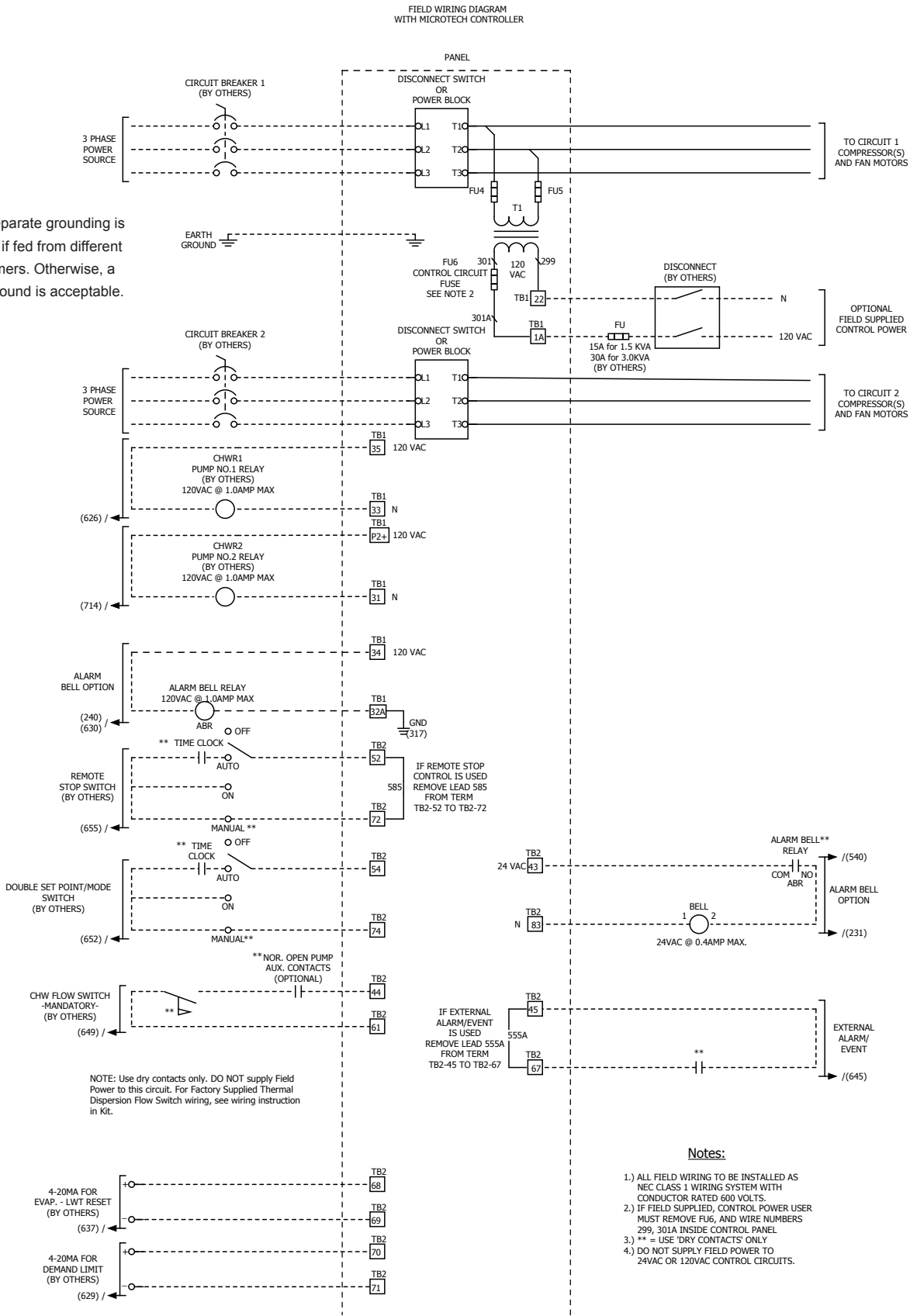

Figure 51: Typical Field Wiring Diagram for Partial Heat Recovery (Single-Point Connection)

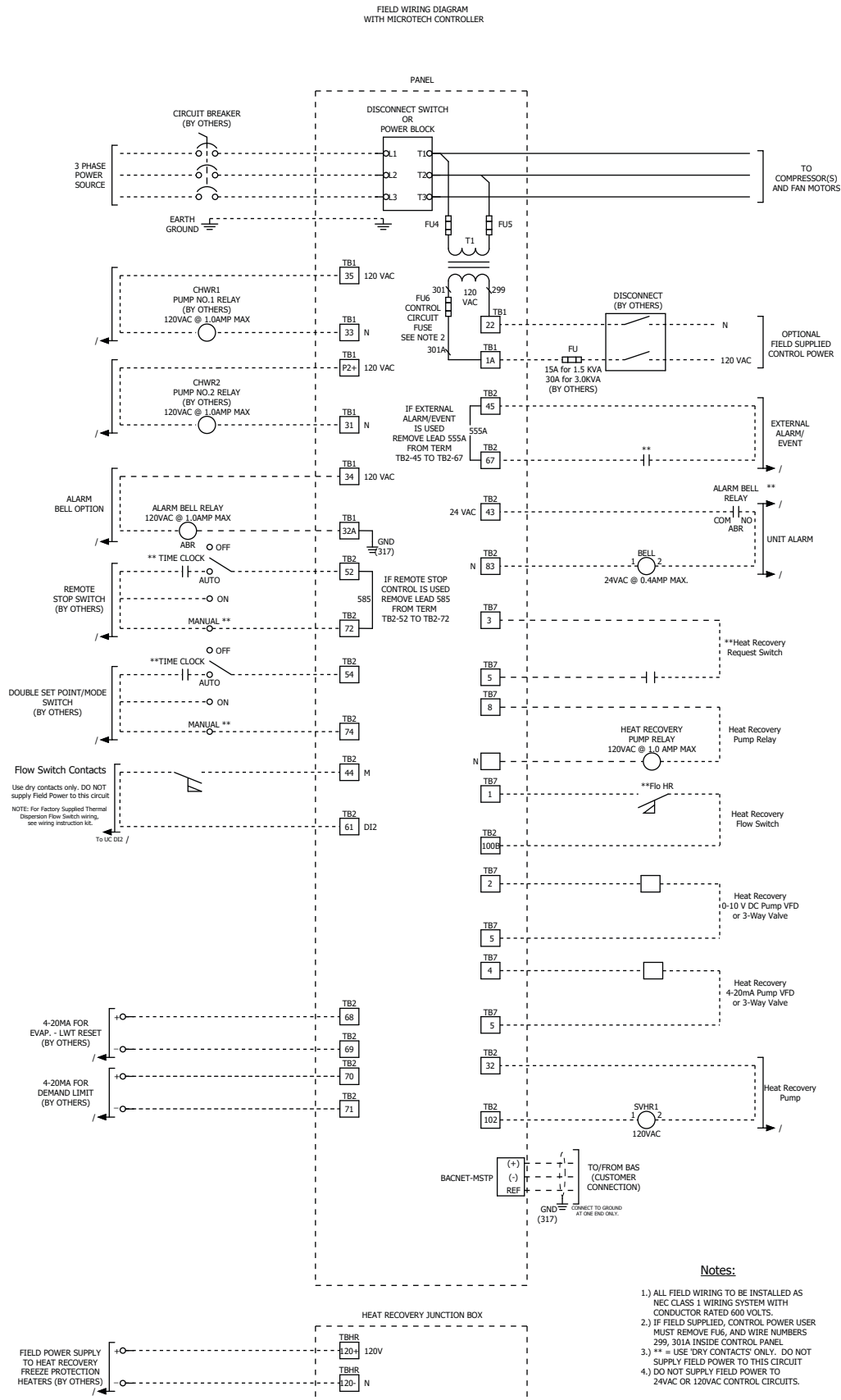
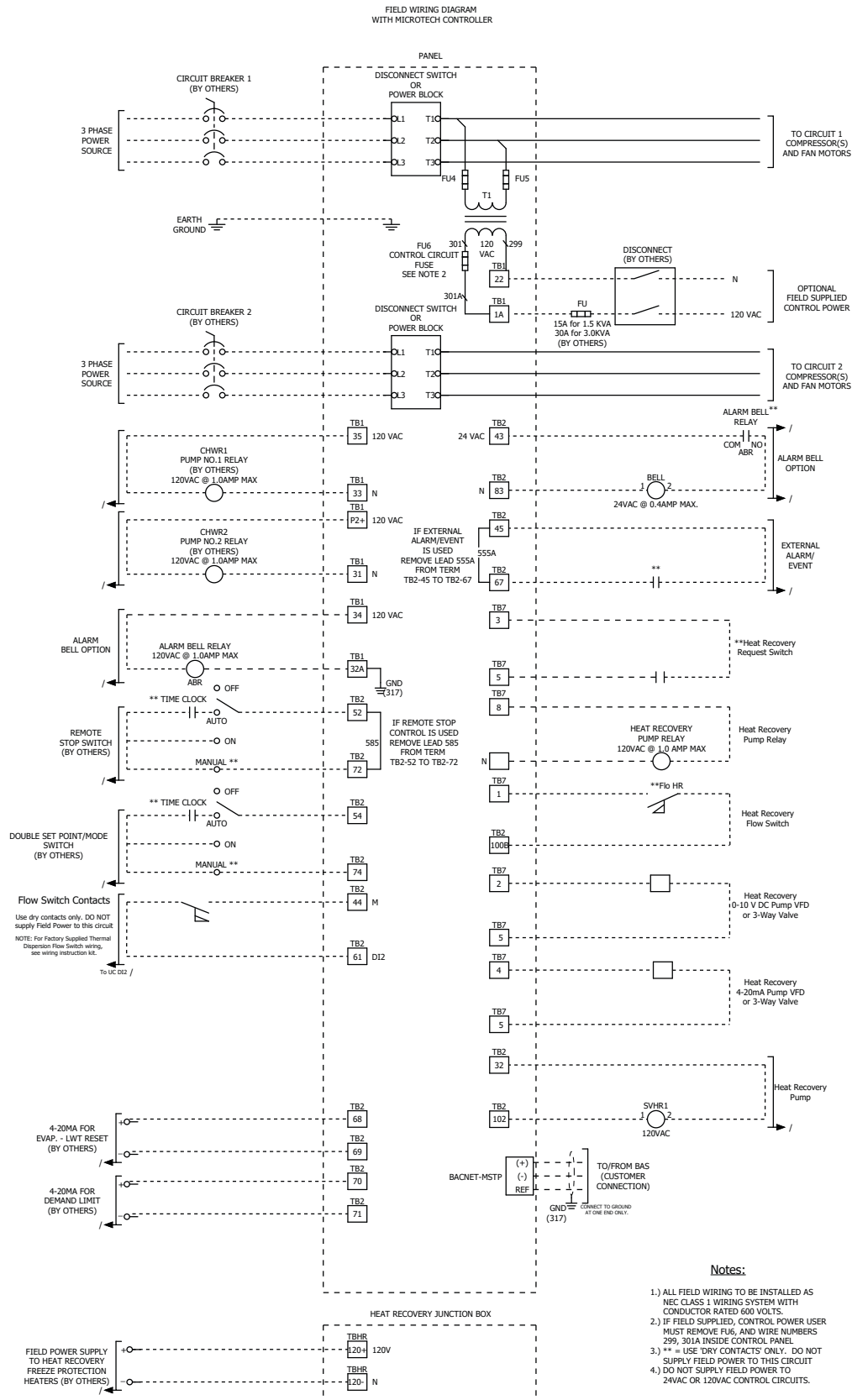



Figure 52: Typical Field Wiring Diagram for Partial Heat Recovery (Multi-Point Connection)



**Table 26: Electrical Data - Single Point (60/50Hz)**

Model Size	Voltage / Freq.	Single Point Field Data				
		Ratings			Lug Range	
		MCA	RFS	MFS	Power Block	Disconnect
030E	208V/60	149	175	175	(1) 2-600MCM	(1) 6-350MCM
	230V/60	149	175	175	(1) 2-600MCM	(1) 6-350MCM
	380V/60	87	100	100	(1) 2-600MCM	(1) 12-1/0
	460V/60	74	80	80	(1) 14-2/0	(1) 12-1/0
	575V/60	64	70	70	(1) 14-2/0	(1) 12-1/0
	400V/50	77	90	90	(1) 14-2/0	(1) 12-1/0
035E	208V/60	163	175	175	(1) 2-600MCM	(1) 6-350MCM
	230V/60	163	175	175	(1) 2-600MCM	(1) 6-350MCM
	380V/60	96	110	110	(1) 2-600MCM	(1) 4-300MCM
	460V/60	77	90	90	(1) 14-2/0	(1) 12-1/0
	575V/60	64	70	70	(1) 14-2/0	(1) 12-1/0
	400V/50	80	90	90	(1) 14-2/0	(1) 12-1/0
040E	208V/60	168	200	200	(1) 2-600MCM	(1) 6-350MCM
	230V/60	168	200	200	(1) 2-600MCM	(1) 6-350MCM
	380V/60	107	125	125	(1) 2-600MCM	(1) 4-300MCM
	460V/60	80	90	90	(1) 14-2/0	(1) 12-1/0
	575V/60	67	80	80	(1) 14-2/0	(1) 12-1/0
	400V/50	83	100	100	(1) 14-2/0	(1) 12-1/0
045E	208V/60	228	250	250	(1) 2-600MCM	(1) 6-350MCM
	230V/60	228	250	250	(1) 2-600MCM	(1) 6-350MCM
	380V/60	117	125	125	(1) 2-600MCM	(1) 4-300MCM
	460V/60	90	100	100	(1) 2-600MCM	(1) 12-1/0
	575V/60	75	90	90	(1) 14-2/0	(1) 12-1/0
	400V/50	94	110	110	(1) 2-600MCM	(1) 4-300MCM
050E	208V/60	241	250	250	(1) 2-600MCM	(2) 3/0-500MCM
	230V/60	241	250	250	(1) 2-600MCM	(2) 3/0-500MCM
	380V/60	131	150	150	(1) 2-600MCM	(1) 4-300MCM
	460V/60	109	125	125	(1) 2-600MCM	(1) 4-300MCM
	575V/60	97	110	110	(1) 2-600MCM	(1) 4-300MCM
	400V/50	107	125	125	(1) 2-600MCM	(1) 4-300MCM
055E	208V/60	251	300	300	(1) 2-600MCM	(2) 3/0-500MCM
	230V/60	251	300	300	(1) 2-600MCM	(2) 3/0-500MCM
	380V/60	147	175	175	(1) 2-600MCM	(1) 6-350MCM
	460V/60	118	125	125	(1) 2-600MCM	(1) 4-300MCM
	575V/60	105	125	125	(1) 2-600MCM	(1) 4-300MCM
	400V/50	119	125	125	(1) 2-600MCM	(1) 4-300MCM
060E	208V/60	260	300	300	(1) 2-600MCM	(2) 3/0-500MCM
	230V/60	260	300	300	(1) 2-600MCM	(2) 3/0-500MCM
	380V/60	161	175	175	(1) 2-600MCM	(1) 6-350MCM
	460V/60	126	150	150	(1) 2-600MCM	(1) 4-300MCM
	575V/60	113	125	125	(1) 2-600MCM	(1) 4-300MCM
	400V/50	129	150	150	(1) 2-600MCM	(1) 4-300MCM

**Table 27: Electrical Data - Single Point (60/50Hz)**

Model Size	Voltage / Freq.	Single Point Field Data				
		Ratings			Lug Range	
		MCA	RFS	MFS	Power Block	Disconnect
065E	208V/60	268	300	300	(1) 2-600MCM	(2) 3/0-500MCM
	230V/60	268	300	300	(1) 2-600MCM	(2) 3/0-500MCM
	380V/60	161	175	175	(1) 2-600MCM	(1) 6-350MCM
	460V/60	129	150	150	(1) 2-600MCM	(1) 4-300MCM
	575V/60	113	125	125	(1) 2-600MCM	(1) 4-300MCM
	400V/50	129	150	150	(1) 2-600MCM	(1) 4-300MCM
070E	208V/60	306	350	350	(1) 2-600MCM	(2) 3/0-500MCM
	230V/60	306	350	350	(1) 2-600MCM	(2) 3/0-500MCM
	380V/60	164	200	200	(1) 2-600MCM	(1) 6-350MCM
	460V/60	138	150	150	(1) 2-600MCM	(1) 4-300MCM
	575V/60	117	125	125	(1) 2-600MCM	(1) 4-300MCM
	400V/50	138	150	150	(1) 2-600MCM	(1) 4-300MCM
075E	208V/60	338	400	400	(1) 2-600MCM	(2) 3/0-500MCM
	230V/60	338	400	400	(1) 2-600MCM	(2) 3/0-500MCM
	380V/60	173	200	200	(1) 14-2/0	(1) 6-350MCM
	460V/60	149	175	175	(1) 14-2/0	(1) 6-350MCM
	575V/60	125	150	150	(1) 14-2/0	(1) 4-300MCM
	400V/50	149	175	175	(1) 14-2/0	(1) 6-350MCM
080E	208V/60	355	400	400	(1) 2-600MCM	(2) 3/0-500MCM
	230V/60	355	400	400	(1) 2-600MCM	(2) 3/0-500MCM
	380V/60	187	225	225	(1) 2-600MCM	(1) 6-350MCM
	460V/60	153	175	175	(1) 14-2/0	(1) 6-350MCM
	575V/60	126	150	150	(1) 14-2/0	(1) 4-300MCM
	400V/50	153	175	175	(1) 14-2/0	(1) 6-350MCM
090E	208V/60	384	450	450	(1) 2-600MCM	(2) 3/0-500MCM
	230V/60	384	450	450	(1) 2-600MCM	(2) 3/0-500MCM
	380V/60	218	250	250	(1) 2-600MCM	(1) 6-350MCM
	460V/60	168	200	200	(1) 14-2/0	(1) 6-350MCM
	575V/60	147	175	175	(1) 14-2/0	(1) 6-350MCM
	400V/50	168	200	200	(1) 14-2/0	(1) 6-350MCM
100E	208V/60	442	500	500	(2) 6-500MCM	(2) 3/0-500MCM
	230V/60	442	500	500	(2) 6-500MCM	(2) 3/0-500MCM
	380V/60	268	300	300	(1) 2-600MCM	(2) 3/0-500MCM
	460V/60	203	250	250	(1) 2-600MCM	(1) 6-350MCM
	575V/60	184	225	225	(1) 2-600MCM	(1) 6-350MCM
	400V/50	203	250	250	(1) 2-600MCM	(1) 6-350MCM
110E	208V/60	490	600	600	(2) 6-500MCM	(2) 3/0-500MCM
	230V/60	490	600	600	(2) 6-500MCM	(2) 3/0-500MCM
	380V/60	294	350	350	(1) 2-600MCM	(2) 3/0-500MCM
	460V/60	227	250	250	(1) 2-600MCM	(1) 6-350MCM
	575V/60	204	250	250	(1) 2-600MCM	(1) 6-350MCM
	400V/50	227	250	250	(1) 2-600MCM	(1) 6-350MCM

MCA = Minimum Current Ampacity, RFS = Recommended Fuse Size, MFS = Maximum Fuse Size.

For RFS, use the given values for intended standard ambient operation. If the operating ambient is intended to be above 105°F, MFS must be used.

**Table 28: Electrical Data - Single Point (60/50Hz)**

Model Size	Voltage / Freq.	Single Point Field Data				
		Ratings			Lug Range	
		MCA	RFS	MFS	Power Block	Disconnect
120E	208V/60	534	600	600	(2) 6-500MCM	(2) 3/0-500MCM
	230V/60	534	600	600	(2) 6-500MCM	(2) 3/0-500MCM
	380V/60	330	400	400	(1) 2-600MCM	(2) 3/0-500MCM
	460V/60	261	300	300	(1) 2-600MCM	(2) 3/0-500MCM
	575V/60	234	250	250	(1) 2-600MCM	(2) 3/0-500MCM
	400V/50	261	300	300	(1) 2-600MCM	(2) 3/0-500MCM
130E	208V/60	569	700	700	(2) 6-500MCM	(3) 2/0-400MCM
	230V/60	569	700	700	(2) 6-500MCM	(3) 2/0-400MCM
	380V/60	358	400	450	(1) 2-600MCM	(2) 3/0-500MCM
	460V/60	284	350	350	(1) 2-600MCM	(2) 3/0-500MCM
	575V/60	239	250	250	(1) 2-600MCM	(2) 3/0-500MCM
	400V/50	284	350	350	(1) 2-600MCM	(2) 3/0-500MCM
140E	208V/60	612	700	700	(2) 6-500MCM	(3) 2/0-400MCM
	230V/60	612	700	700	(2) 6-500MCM	(3) 2/0-400MCM
	380V/60	388	450	450	(1) 2-600MCM	(2) 3/0-500MCM
	460V/60	309	350	350	(1) 2-600MCM	(2) 3/0-500MCM
	575V/60	248	300	300	(1) 2-600MCM	(2) 3/0-500MCM
	400V/50	309	350	350	(1) 2-600MCM	(2) 3/0-500MCM
150E	208V/60	640	700	700	(2) 6-500MCM	(3) 2/0-400MCM
	230V/60	640	700	700	(2) 6-500MCM	(3) 2/0-400MCM
	380V/60	410	500	500	(1) 2-600MCM	(2) 3/0-500MCM
	460V/60	328	400	400	(1) 2-600MCM	(2) 3/0-500MCM
	575V/60	252	300	300	(1) 2-600MCM	(2) 3/0-500MCM
	400V/50	328	400	400	(1) 2-600MCM	(2) 3/0-500MCM
161E	208V/60	668	800	800	(2) 6-500MCM	(3) 2/0-400MCM
	230V/60	668	800	800	(2) 6-500MCM	(3) 2/0-400MCM
	380V/60	432	500	500	(1) 2-600MCM	(2) 3/0-500MCM
	460V/60	346	400	400	(1) 2-600MCM	(2) 3/0-500MCM
	575V/60	255	300	300	(1) 2-600MCM	(2) 3/0-500MCM
	400V/50	346	400	400	(1) 2-600MCM	(2) 3/0-500MCM
170E	208V/60	734	800	800	(2) 6-500MCM	(4) 4/0-500MCM
	230V/60	734	800	800	(2) 6-500MCM	(4) 4/0-500MCM
	380V/60	442	500	500	(2) 6-500MCM	(2) 3/0-500MCM
	460V/60	355	400	400	(1) 2-600MCM	(2) 3/0-500MCM
	575V/60	309	350	350	(1) 2-600MCM	(2) 3/0-500MCM
	400V/50	355	400	400	(1) 2-600MCM	(2) 3/0-500MCM
180E	208V/60	875	1000	1000	--	(4) 4/0-500MCM
	230V/60	875	1000	1000	--	(4) 4/0-500MCM
	380V/60	479	500	500	(2) 6-500MCM	(2) 3/0-500MCM
	460V/60	394	450	450	(1) 2-600MCM	(2) 3/0-500MCM
	575V/60	339	350	350	(1) 2-600MCM	(2) 3/0-500MCM
	400V/50	394	450	450	(1) 2-600MCM	(2) 3/0-500MCM

**Table 29: Electrical Data - Single Point (60/50Hz)**

Model Size	Voltage / Freq.	Single Point Field Data				
		Ratings			Lug Range	
		MCA	RFS	MFS	Power Block	Disconnect
191E	208V/60	848	1000	1000	(4) 2-600MCM	(4) 4/0-500MCM
	230V/60	848	1000	1000	(4) 2-600MCM	(4) 4/0-500MCM
	380V/60	508	600	600	(2) 6-500MCM	(2) 3/0-500MCM
	460V/60	424	500	500	(2) 6-500MCM	(2) 3/0-500MCM
	575V/60	348	400	400	(2) 6-500MCM	(2) 3/0-500MCM
	400V/50	424	500	500	(1) 2-600MCM	(2) 3/0-500MCM
211E	208V/60	890	1000	1000	(4) 2-600MCM	(4) 4/0-500MCM
	230V/60	890	1000	1000	(4) 2-600MCM	(4) 4/0-500MCM
	380V/60	525	600	600	(2) 6-500MCM	(2) 3/0-500MCM
	460V/60	443	500	500	(2) 6-500MCM	(2) 3/0-500MCM
	575V/60	351	400	400	(2) 6-500MCM	(2) 3/0-500MCM
	400V/50	443	500	500	(1) 2-600MCM	(2) 3/0-500MCM
226E	208V/60	943	1000	1000	(4) 2-600MCM	(4) 4/0-500MCM
	230V/60	943	1000	1000	(4) 2-600MCM	(4) 4/0-500MCM
	380V/60	551	600	600	(2) 6-500MCM	(3) 2/0-400MCM
	460V/60	469	500	500	(2) 6-500MCM	(2) 3/0-500MCM
	575V/60	359	400	400	(2) 6-500MCM	(2) 3/0-500MCM
	400V/50	469	500	500	(1) 2-600MCM	(2) 3/0-500MCM
241E	208V/60	1071	1200	1200	(4) 2-600MCM	(4) 4/0-500MCM
	230V/60	1071	1200	1200	(4) 2-600MCM	(4) 4/0-500MCM
	380V/60	602	700	700	(2) 6-500MCM	(3) 2/0-400MCM
	460V/60	525	600	600	(2) 6-500MCM	(2) 3/0-500MCM
	575V/60	367	400	400	(2) 6-500MCM	(2) 3/0-500MCM
	400V/50	525	600	600	(1) 2-600MCM	(2) 3/0-500MCM

MCA = Minimum Current Ampacity, RFS = Recommended Fuse Size, MFS = Maximum Fuse Size.

For RFS, use the given values for intended standard ambient operation. If the operating ambient is intended to be above 105°F, MFS must be used.

**Table 30: Electrical Data - Multiple Point (60/50 Hz)**

Model Size	Voltage / Frequency	Multiple Point Field Data - Circuit #1					Multiple Point Field Data - Circuit #2				
		Ratings			Lug Range		Ratings			Lug Range	
		MCA	RFS	MFS	Power Block	Disconnect Switch	MCA	RFS	MFS	Power Block	Disconnect Switch
030E	208V/60	78	100	100	(1) 14-2/0	(1) 12-1/0	78	100	100	(1) 14-2/0	(1) 4-300MCM
	230V/60	78	100	100	(1) 14-2/0	(1) 12-1/0	78	100	100	(1) 14-2/0	(1) 4-300MCM
	380V/60	46	60	60	(1) 14-2/0	(1) 12-1/0	46	60	60	(1) 14-2/0	(1) 12-1/0
	460V/60	39	50	50	(1) 14-2/0	(1) 12-1/0	39	50	50	(1) 14-2/0	(1) 12-1/0
	575V/60	34	40	45	(1) 14-2/0	(1) 12-1/0	34	40	45	(1) 14-2/0	(1) 12-1/0
	400V/50	40	50	50	(1) 14-2/0	(1) 12-1/0	40	50	50	(1) 14-2/0	(1) 12-1/0
035E	208V/60	82	100	110	(1) 14-2/0	(1) 4-300MCM	88	110	110	(1) 14-2/0	(1) 4-300MCM
	230V/60	82	100	110	(1) 14-2/0	(1) 4-300MCM	88	110	110	(1) 14-2/0	(1) 4-300MCM
	380V/60	44	60	60	(1) 14-2/0	(1) 12-1/0	56	70	70	(1) 14-2/0	(1) 12-1/0
	460V/60	39	50	50	(1) 14-2/0	(1) 12-1/0	42	50	50	(1) 14-2/0	(1) 12-1/0
	575V/60	32	40	40	(1) 14-2/0	(1) 12-1/0	35	45	45	(1) 14-2/0	(1) 12-1/0
	400V/50	40	50	50	(1) 14-2/0	(1) 12-1/0	44	60	60	(1) 14-2/0	(1) 12-1/0
040E	208V/60	88	110	110	(1) 14-2/0	(1) 4-300MCM	88	110	110	(1) 14-2/0	(1) 4-300MCM
	230V/60	88	110	110	(1) 14-2/0	(1) 4-300MCM	88	110	110	(1) 14-2/0	(1) 4-300MCM
	380V/60	56	70	70	(1) 14-2/0	(1) 12-1/0	56	70	70	(1) 14-2/0	(1) 12-1/0
	460V/60	42	50	50	(1) 14-2/0	(1) 12-1/0	42	50	50	(1) 14-2/0	(1) 12-1/0
	575V/60	35	45	45	(1) 14-2/0	(1) 12-1/0	35	45	45	(1) 14-2/0	(1) 12-1/0
	400V/50	44	60	60	(1) 14-2/0	(1) 12-1/0	44	60	60	(1) 14-2/0	(1) 12-1/0
045E	208V/60	120	150	150	(1) 14-2/0	(1) 4-300MCM	120	150	150	(1) 14-2/0	(1) 6-350MCM
	230V/60	120	150	150	(1) 14-2/0	(1) 4-300MCM	120	150	150	(1) 14-2/0	(1) 6-350MCM
	380V/60	62	80	80	(1) 14-2/0	(1) 12-1/0	62	80	80	(1) 14-2/0	(1) 12-1/0
	460V/60	48	60	60	(1) 14-2/0	(1) 12-1/0	48	60	60	(1) 14-2/0	(1) 12-1/0
	575V/60	39	50	50	(1) 14-2/0	(1) 12-1/0	39	50	50	(1) 14-2/0	(1) 12-1/0
	400V/50	49	60	60	(1) 14-2/0	(1) 12-1/0	49	60	60	(1) 14-2/0	(1) 12-1/0
050E	208V/60	127	150	175	(1) 14-2/0	(1) 6-350MCM	127	150	175	(1) 14-2/0	(1) 6-350MCM
	230V/60	127	150	175	(1) 14-2/0	(1) 6-350MCM	127	150	175	(1) 14-2/0	(1) 6-350MCM
	380V/60	69	90	90	(1) 14-2/0	(1) 12-1/0	69	90	90	(1) 14-2/0	(1) 12-1/0
	460V/60	58	70	80	(1) 14-2/0	(1) 12-1/0	58	70	80	(1) 14-2/0	(1) 12-1/0
	575V/60	51	60	70	(1) 14-2/0	(1) 12-1/0	51	60	70	(1) 14-2/0	(1) 12-1/0
	400V/50	56	70	70	(1) 14-2/0	(1) 12-1/0	56	70	70	(1) 14-2/0	(1) 12-1/0
055E	208V/60	127	150	175	(1) 14-2/0	(1) 6-350MCM	137	175	175	(1) 14-2/0	(1) 6-350MCM
	230V/60	127	150	175	(1) 14-2/0	(1) 6-350MCM	137	175	175	(1) 14-2/0	(1) 6-350MCM
	380V/60	69	90	90	(1) 14-2/0	(1) 12-1/0	85	110	110	(1) 14-2/0	(1) 4-300MCM
	460V/60	58	70	80	(1) 14-2/0	(1) 12-1/0	66	80	90	(1) 14-2/0	(1) 12-1/0
	575V/60	51	60	70	(1) 14-2/0	(1) 12-1/0	59	70	80	(1) 14-2/0	(1) 12-1/0
	400V/50	56	70	70	(1) 14-2/0	(1) 12-1/0	68	80	90	(1) 14-2/0	(1) 12-1/0
060E	208V/60	137	175	175	(1) 14-2/0	(1) 6-350MCM	137	175	175	(1) 14-2/0	(1) 6-350MCM
	230V/60	137	175	175	(1) 14-2/0	(1) 6-350MCM	137	175	175	(1) 14-2/0	(1) 6-350MCM
	380V/60	85	110	110	(1) 14-2/0	(1) 4-300MCM	85	110	110	(1) 14-2/0	(1) 4-300MCM
	460V/60	66	80	90	(1) 14-2/0	(1) 12-1/0	66	80	90	(1) 14-2/0	(1) 12-1/0
	575V/60	59	70	80	(1) 14-2/0	(1) 12-1/0	59	70	80	(1) 14-2/0	(1) 12-1/0
	400V/50	68	80	90	(1) 14-2/0	(1) 12-1/0	68	80	90	(1) 14-2/0	(1) 12-1/0

**NOTE:** MCA = Minimum Current Ampacity, RFS = Recommended Fuse Size, MFS = Maximum Fuse Size.  
 For RFS, use the given values for intended standard ambient operation. If the operating ambient is intended to be above 105°F, MFS must be used.

**Table 31: Electrical Data - Multiple Point (60/50 Hz)**

Model Size	Voltage / Frequency	Multiple Point Field Data - Circuit #1					Multiple Point Field Data - Circuit #2				
		Ratings			Lug Range		Ratings			Lug Range	
		MCA	RFS	MFS	Power Block	Disconnect Switch	MCA	RFS	MFS	Power Block	Disconnect Switch
065E	208V/60	141	175	175	(1) 14-2/0	(1) 6-350MCM	141	175	175	(1) 14-2/0	(1) 6-350MCM
	230V/60	141	175	175	(1) 14-2/0	(1) 6-350MCM	141	175	175	(1) 14-2/0	(1) 6-350MCM
	380V/60	85	110	110	(1) 14-2/0	(1) 4-300MCM	85	110	110	(1) 14-2/0	(1) 4-300MCM
	460V/60	68	80	90	(1) 14-2/0	(1) 12-1/0	68	80	90	(1) 14-2/0	(1) 12-1/0
	575V/60	59	70	80	(1) 14-2/0	(1) 12-1/0	59	70	80	(1) 14-2/0	(1) 12-1/0
	400V/50	68	80	90	(1) 14-2/0	(1) 12-1/0	68	80	90	(1) 14-2/0	(1) 12-1/0
070E	208V/60	162	200	225	(1) 2-600MCM	(1) 6-350MCM	162	200	225	(1) 2-600MCM	(1) 6-350MCM
	230V/60	162	200	225	(1) 2-600MCM	(1) 6-350MCM	162	200	225	(1) 2-600MCM	(1) 6-350MCM
	380V/60	86	110	110	(1) 14-2/0	(1) 4-300MCM	86	110	110	(1) 14-2/0	(1) 4-300MCM
	460V/60	73	90	100	(1) 14-2/0	(1) 12-1/0	73	90	100	(1) 14-2/0	(1) 4-300MCM
	575V/60	62	80	80	(1) 14-2/0	(1) 12-1/0	62	80	80	(1) 14-2/0	(1) 12-1/0
	400V/50	73	90	100	(1) 14-2/0	(1) 12-1/0	73	90	100	(1) 14-2/0	(1) 4-300MCM
075E	208V/60	186	225	250	(1) 2-600MCM	(1) 6-350MCM	170	225	225	(1) 14-2/0	(1) 6-350MCM
	230V/60	186	225	250	(1) 2-600MCM	(1) 6-350MCM	170	225	225	(1) 14-2/0	(1) 6-350MCM
	380V/60	92	110	125	(1) 14-2/0	(1) 4-300MCM	91	110	125	(1) 14-2/0	(1) 4-300MCM
	460V/60	80	100	110	(1) 14-2/0	(1) 4-300MCM	76	100	100	(1) 14-2/0	(1) 4-300MCM
	575V/60	66	80	90	(1) 14-2/0	(1) 12-1/0	65	80	90	(1) 14-2/0	(1) 12-1/0
	400V/50	80	100	110	(1) 14-2/0	(1) 4-300MCM	76	100	100	(1) 14-2/0	(1) 4-300MCM
080E	208V/60	186	225	250	(1) 2-600MCM	(1) 6-350MCM	186	225	250	(1) 2-600MCM	(2) 3/0-500MCM
	230V/60	186	225	250	(1) 2-600MCM	(1) 6-350MCM	186	225	250	(1) 2-600MCM	(2) 3/0-500MCM
	380V/60	98	125	125	(1) 14-2/0	(1) 4-300MCM	98	125	125	(1) 14-2/0	(1) 6-350MCM
	460V/60	80	100	110	(1) 14-2/0	(1) 4-300MCM	80	100	110	(1) 14-2/0	(1) 4-300MCM
	575V/60	66	80	90	(1) 14-2/0	(1) 12-1/0	66	80	90	(1) 14-2/0	(1) 4-300MCM
	400V/50	80	100	110	(1) 14-2/0	(1) 4-300MCM	80	100	110	(1) 14-2/0	(1) 4-300MCM
090E	208V/60	203	250	250	(1) 2-600MCM	(1) 6-350MCM	203	250	250	(1) 2-600MCM	(2) 3/0-500MCM
	230V/60	203	250	250	(1) 2-600MCM	(1) 6-350MCM	203	250	250	(1) 2-600MCM	(2) 3/0-500MCM
	380V/60	115	150	150	(1) 14-2/0	(1) 4-300MCM	115	150	150	(1) 14-2/0	(1) 6-350MCM
	460V/60	89	110	125	(1) 14-2/0	(1) 4-300MCM	89	110	125	(1) 14-2/0	(1) 4-300MCM
	575V/60	78	100	110	(1) 14-2/0	(1) 4-300MCM	78	100	110	(1) 14-2/0	(1) 4-300MCM
	400V/50	89	110	125	(1) 14-2/0	(1) 4-300MCM	89	110	125	(1) 14-2/0	(1) 4-300MCM
100E	208V/60	215	300	300	(1) 2-600MCM	(2) 3/0-500MCM	248	300	350	(1) 2-600MCM	(2) 3/0-500MCM
	230V/60	215	300	300	(1) 2-600MCM	(2) 3/0-500MCM	248	300	350	(1) 2-600MCM	(2) 3/0-500MCM
	380V/60	129	175	175	(1) 14-2/0	(1) 6-350MCM	152	200	200	(1) 14-2/0	(2) 3/0-500MCM
	460V/60	96	125	125	(1) 14-2/0	(1) 4-300MCM	117	150	150	(1) 14-2/0	(1) 6-350MCM
	575V/60	87	110	110	(1) 14-2/0	(1) 4-300MCM	105	150	150	(1) 14-2/0	(1) 6-350MCM
	400V/50	96	125	125	(1) 14-2/0	(1) 4-300MCM	117	150	150	(1) 14-2/0	(1) 6-350MCM
110E	208V/60	259	350	350	(1) 2-600MCM	(2) 3/0-500MCM	259	350	350	(1) 2-600MCM	(2) 3/0-500MCM
	230V/60	259	350	350	(1) 2-600MCM	(2) 3/0-500MCM	259	350	350	(1) 2-600MCM	(2) 3/0-500MCM
	380V/60	156	200	225	(1) 14-2/0	(1) 6-350MCM	156	200	225	(1) 14-2/0	(2) 3/0-500MCM
	460V/60	120	150	175	(1) 14-2/0	(1) 6-350MCM	120	150	175	(1) 14-2/0	(1) 6-350MCM
	575V/60	108	150	150	(1) 14-2/0	(1) 4-300MCM	108	150	150	(1) 14-2/0	(1) 6-350MCM
	400V/50	120	150	175	(1) 14-2/0	(1) 6-350MCM	120	150	175	(1) 14-2/0	(1) 6-350MCM

**NOTE:** MCA = Minimum Current Ampacity, RFS = Recommended Fuse Size, MFS = Maximum Fuse Size.  
 For RFS, use the given values for intended standard ambient operation. If the operating ambient is intended to be above 105°F, MFS must be used.

**Table 32: Electrical Data - Multiple Point (60/50Hz)**

Model Size	Voltage / Frequency	Multiple Point Field Data - Circuit #1					Multiple Point Field Data - Circuit #2				
		Ratings			Lug Range		Ratings			Lug Range	
		MCA	RFS	MFS	Power Block	Disconnect Switch	MCA	RFS	MFS	Power Block	Disconnect Switch
120E	208V/60	281	350	350	(1) 2-600MCM	(2) 3/0-500MCM	281	350	350	(1) 2-600MCM	(2) 3/0-500MCM
	230V/60	281	350	350	(1) 2-600MCM	(2) 3/0-500MCM	281	350	350	(1) 2-600MCM	(2) 3/0-500MCM
	380V/60	174	225	225	(1) 14-2/0	(1) 6-350MCM	174	225	225	(1) 14-2/0	(2) 3/0-500MCM
	460V/60	137	175	175	(1) 14-2/0	(1) 6-350MCM	137	175	175	(1) 14-2/0	(1) 6-350MCM
	575V/60	123	150	150	(1) 14-2/0	(1) 4-300MCM	123	150	150	(1) 14-2/0	(1) 6-350MCM
	400V/50	137	175	175	(1) 14-2/0	(1) 6-350MCM	137	175	175	(1) 14-2/0	(1) 6-350MCM
130E	208V/60	281	350	350	(1) 2-600MCM	(2) 3/0-500MCM	316	400	450	(1) 2-600MCM	(2) 3/0-500MCM
	230V/60	281	350	350	(1) 2-600MCM	(2) 3/0-500MCM	316	400	450	(1) 2-600MCM	(2) 3/0-500MCM
	380V/60	174	225	225	(1) 14-2/0	(1) 6-350MCM	201	250	250	(1) 2-600MCM	(2) 3/0-500MCM
	460V/60	137	175	175	(1) 14-2/0	(1) 6-350MCM	160	200	225	(1) 14-2/0	(2) 3/0-500MCM
	575V/60	123	150	150	(1) 14-2/0	(1) 4-300MCM	128	175	175	(1) 14-2/0	(1) 6-350MCM
	400V/50	137	175	175	(1) 14-2/0	(1) 6-350MCM	160	200	225	(1) 14-2/0	(2) 3/0-500MCM
140E	208V/60	324	400	450	(1) 2-600MCM	(2) 3/0-500MCM	324	400	450	(1) 2-600MCM	(2) 3/0-500MCM
	230V/60	324	400	450	(1) 2-600MCM	(2) 3/0-500MCM	324	400	450	(1) 2-600MCM	(2) 3/0-500MCM
	380V/60	206	250	250	(1) 2-600MCM	(1) 6-350MCM	206	250	250	(1) 2-600MCM	(2) 3/0-500MCM
	460V/60	164	200	225	(1) 14-2/0	(1) 6-350MCM	164	200	225	(1) 14-2/0	(2) 3/0-500MCM
	575V/60	131	175	175	(1) 14-2/0	(1) 6-350MCM	131	175	175	(1) 14-2/0	(1) 6-350MCM
	400V/50	164	200	225	(1) 14-2/0	(1) 6-350MCM	164	200	225	(1) 14-2/0	(2) 3/0-500MCM
150E	208V/60	324	400	450	(1) 2-600MCM	(2) 3/0-500MCM	351	450	450	(1) 2-600MCM	(2) 3/0-500MCM
	230V/60	324	400	450	(1) 2-600MCM	(2) 3/0-500MCM	351	450	450	(1) 2-600MCM	(2) 3/0-500MCM
	380V/60	206	250	250	(1) 2-600MCM	(1) 6-350MCM	228	300	300	(1) 2-600MCM	(2) 3/0-500MCM
	460V/60	164	200	225	(1) 14-2/0	(1) 6-350MCM	182	225	250	(1) 2-600MCM	(2) 3/0-500MCM
	575V/60	131	175	175	(1) 14-2/0	(1) 6-350MCM	134	175	175	(1) 14-2/0	(1) 6-350MCM
	400V/50	164	200	225	(1) 14-2/0	(1) 6-350MCM	182	225	250	(1) 2-600MCM	(2) 3/0-500MCM
161E	208V/60	358	450	450	(1) 2-600MCM	(2) 3/0-500MCM	358	450	450	(1) 2-600MCM	(2) 3/0-500MCM
	230V/60	358	450	450	(1) 2-600MCM	(2) 3/0-500MCM	358	450	450	(1) 2-600MCM	(2) 3/0-500MCM
	380V/60	212	250	250	(1) 2-600MCM	(1) 6-350MCM	212	250	250	(1) 2-600MCM	(2) 3/0-500MCM
	460V/60	165	200	200	(1) 14-2/0	(1) 6-350MCM	165	200	200	(1) 14-2/0	(2) 3/0-500MCM
	575V/60	146	175	175	(1) 14-2/0	(1) 6-350MCM	146	175	175	(1) 14-2/0	(1) 6-350MCM
	400V/50	165	200	200	(1) 14-2/0	(1) 6-350MCM	165	200	200	(1) 14-2/0	(2) 3/0-500MCM
170E	208V/60	358	450	450	(1) 2-600MCM	(2) 3/0-500MCM	405	500	500	(1) 2-600MCM	(2) 3/0-500MCM
	230V/60	358	450	450	(1) 2-600MCM	(2) 3/0-500MCM	405	500	500	(1) 2-600MCM	(2) 3/0-500MCM
	380V/60	212	250	250	(1) 2-600MCM	(1) 6-350MCM	248	300	300	(1) 2-600MCM	(2) 3/0-500MCM
	460V/60	165	200	200	(1) 14-2/0	(1) 6-350MCM	204	250	250	(1) 2-600MCM	(2) 3/0-500MCM
	575V/60	146	175	175	(1) 14-2/0	(1) 6-350MCM	176	200	225	(1) 2-600MCM	(1) 6-350MCM
	400V/50	165	200	200	(1) 14-2/0	(1) 6-350MCM	204	250	250	(1) 2-600MCM	(2) 3/0-500MCM
180E	208V/60	453	500	500	(2) 6-500MCM	(2) 3/0-500MCM	453	500	500	(2) 6-500MCM	(2) 3/0-500MCM
	230V/60	453	500	500	(2) 6-500MCM	(2) 3/0-500MCM	453	500	500	(2) 6-500MCM	(2) 3/0-500MCM
	380V/60	248	300	300	(1) 2-600MCM	(2) 3/0-500MCM	248	300	300	(1) 2-600MCM	(2) 3/0-500MCM
	460V/60	204	250	250	(1) 2-600MCM	(1) 6-350MCM	204	250	250	(1) 2-600MCM	(2) 3/0-500MCM
	575V/60	176	200	225	(1) 2-600MCM	(1) 6-350MCM	176	200	225	(1) 2-600MCM	(2) 3/0-500MCM
	400V/50	204	250	250	(1) 2-600MCM	(1) 6-350MCM	204	250	250	(1) 2-600MCM	(2) 3/0-500MCM

**NOTE:** MCA = Minimum Current Ampacity, RFS = Recommended Fuse Size, MFS = Maximum Fuse Size.  
 For RFS, use the given values for intended standard ambient operation. If the operating ambient is intended to be above 105°F, MFS must be used.



**Table 33: Electrical Data - Multiple Point (60/50Hz)**

Model Size	Voltage / Frequency	Multiple Point Field Data - Circuit #1					Multiple Point Field Data - Circuit #2				
		Ratings			Lug Range		Ratings			Lug Range	
		MCA	RFS	MFS	Power Block	Disconnect Switch	MCA	RFS	MFS	Power Block	Disconnect Switch
191E	208V/60	413	500	500	(1) 2-600MCM	(2) 3/0-500MCM	464	600	600	(2) 6-500MCM	(3) 2/0-400MCM
	230V/60	413	500	500	(1) 2-600MCM	(2) 3/0-500MCM	464	600	600	(2) 6-500MCM	(3) 2/0-400MCM
	380V/60	252	300	300	(1) 2-600MCM	(2) 3/0-500MCM	274	350	350	(1) 2-600MCM	(2) 3/0-500MCM
	460V/60	208	250	250	(1) 2-600MCM	(1) 6-350MCM	231	300	300	(1) 2-600MCM	(2) 3/0-500MCM
	575V/60	179	225	225	(1) 2-600MCM	(1) 6-350MCM	182	225	225	(1) 2-600MCM	(2) 3/0-500MCM
	400V/50	208	250	250	(1) 2-600MCM	(1) 6-350MCM	231	300	300	(1) 2-600MCM	(2) 3/0-500MCM
211E	208V/60	464	600	600	(2) 6-500MCM	(2) 3/0-500MCM	464	600	600	(2) 6-500MCM	(3) 2/0-400MCM
	230V/60	464	600	600	(2) 6-500MCM	(2) 3/0-500MCM	464	600	600	(2) 6-500MCM	(3) 2/0-400MCM
	380V/60	274	350	350	(1) 2-600MCM	(2) 3/0-500MCM	274	350	350	(1) 2-600MCM	(2) 3/0-500MCM
	460V/60	231	300	300	(1) 2-600MCM	(2) 3/0-500MCM	231	300	300	(1) 2-600MCM	(2) 3/0-500MCM
	575V/60	182	225	225	(1) 2-600MCM	(2) 3/0-500MCM	182	225	225	(1) 2-600MCM	(2) 3/0-500MCM
	400V/50	231	300	300	(1) 2-600MCM	(1) 6-350MCM	231	300	300	(1) 2-600MCM	(2) 3/0-500MCM
226E	208V/60	483	600	600	(2) 6-500MCM	(2) 3/0-500MCM	494	600	600	(2) 6-500MCM	(3) 2/0-400MCM
	230V/60	483	600	600	(2) 6-500MCM	(2) 3/0-500MCM	494	600	600	(2) 6-500MCM	(3) 2/0-400MCM
	380V/60	278	350	350	(1) 2-600MCM	(2) 3/0-500MCM	295	350	350	(1) 2-600MCM	(2) 3/0-500MCM
	460V/60	235	300	300	(1) 2-600MCM	(2) 3/0-500MCM	253	300	300	(1) 2-600MCM	(2) 3/0-500MCM
	575V/60	185	225	225	(1) 2-600MCM	(2) 3/0-500MCM	187	225	225	(1) 2-600MCM	(2) 3/0-500MCM
	400V/50	235	300	300	(1) 2-600MCM	(1) 6-350MCM	253	300	300	(1) 2-600MCM	(2) 3/0-500MCM
241E	208V/60	555	700	700	(2) 6-500MCM	(3) 2/0-400MCM	555	700	700	(2) 6-500MCM	(3) 2/0-400MCM
	230V/60	555	700	700	(2) 6-500MCM	(3) 2/0-400MCM	555	700	700	(2) 6-500MCM	(3) 2/0-400MCM
	380V/60	312	400	400	(1) 2-600MCM	(2) 3/0-500MCM	312	400	400	(1) 2-600MCM	(2) 3/0-500MCM
	460V/60	272	300	300	(1) 2-600MCM	(2) 3/0-500MCM	272	300	300	(1) 2-600MCM	(2) 3/0-500MCM
	575V/60	190	225	225	(1) 2-600MCM	(2) 3/0-500MCM	190	225	225	(1) 2-600MCM	(2) 3/0-500MCM
	400V/50	272	300	300	(1) 2-600MCM	(1) 6-350MCM	272	300	300	(1) 2-600MCM	(2) 3/0-500MCM

**NOTE:** MCA = Minimum Current Ampacity, RFS = Recommended Fuse Size, MFS = Maximum Fuse Size.  
 For RFS, use the given values for intended standard ambient operation. If the operating ambient is intended to be above 105°F, MFS must be used.

## Controls Options & Accessories

### **RapidRestore® and Fast Loading**

Allows the unit to restart and to reach full load more quickly than standard in case of a power interruption. After a power loss duration of up to 180 seconds, once power is restored, the time for a Trailblazer® chiller to restart is less than 125 seconds with the chiller reaching full load within 220 seconds from power restoration.

### **Fast Loading Stand-By Chiller**

Gives the system greater response time by starting a stand-by chiller and reaching full load capacity in 115 seconds (assumes conditions require full load capacity).

### **Hot Gas Bypass (Factory Installed)**

Hot gas bypass permits unit operation down to 10% of full load capacity. This option includes a factory-mounted hot gas bypass valve, solenoid valve, and manual shutoff valve (models 075-241 only) for each circuit.

### **High Efficiency Variable Speed Condenser Fans**

High efficiency adds variable speed drives to the condenser fans on the chiller. The MicroTech® III controller adjusts the speed of the condenser fans using the VFDs to optimize chiller efficiency and maintain proper head pressure. This feature improves part load efficiency substantially and offers the ability to operate in low ambient conditions down to -10°F. Models 075-241 only.

All High Efficiency Trailblazer® models with fully variable speed fans also include a sound reduction mode to allow for reduced-sound operation. Based on a user-settable time schedule, the chiller will enter the reduced noise mode, which will limit the speed of the condenser fans in order to reduce sound levels. This feature is especially helpful in areas that have more rigorous sound restrictions during certain times of day. While the lower fan speed may have a slight impact on the maximum unit capacity during hot outdoor conditions, the chiller can be set to automatically override the fan speed restrictions if additional capacity is needed. This way, the unit will always optimize between required capacity and the lowest sound level possible.

### **Low Ambient Control (Factory Installed)**

Optional fan VFD control allows unit operation down to -10°F (-23°C). Not available on 380 volt (60 Hz) units.

### **High Ambient Control Panel**

Includes an exhaust fan with rain hood, two inlet screens with filters, necessary controls and wiring. Required for operation from 105°F to 125°F (40°C to 52°C) ambient temperature. This panel is included on units with Low Ambient Control, regardless of ambient temperature, to dissipate additional VFD heat.

### **Power Factor Correction Capacitors**

Option to add power factor correction capacitors to improve the chiller's power factor. Compressor power factor is corrected to approximately 0.95 at standard conditions.

### **Water Flow Switch (Field Installed)**

A thermal dispersion water flow switch is available for field installation in the chilled water piping to avoid evaporator freeze-up under low or no flow conditions. Terminals are provided in the unit control center for field hook-up of the water flow switch. If this option is not ordered with the unit, then a field supplied water flow switch must be installed.

### **Water Flow Switch (Factory Installed)**

A factory-mounted and wired thermal dispersion flow switch to avoid evaporator freeze-up under low or no flow conditions.

### **Alarm Bell (Field Installed)**

Field installed and wired to the control panel to provide remote indication of unit alarm condition.

### **Remote Operator Interface Panel (Field Installed)**

A remote interface panel, field wired to the unit, providing all the data viewable on the unit's controller, including alarm clearing and setpoint change capability. See "Intelligent Equipment®" on page 5 for details.

### **BAS Interface - Open Choices™ (Field Installed)**

The preferred module is shipped loose for field installation on the Microtech® III controller to provide the interface to the following standard protocols:

- BACnet®/IP
- Modbus®
- BACnet® Ethernet
- LonMark®

### **Intelligent Equipment®**

Intelligent Equipment (IE) from Daikin Applied is a secure, cloud-based controls solution that enables delivery equipment and/or system information to customers via web or mobile devices. A power measurement module and communications gateway installed on Daikin equipment enables the unit to be directly connected to the Internet via wireless (cellular, Wi-Fi) or local area network (LAN), providing management, monitoring control analysis and decision-making functionality for Daikin chiller systems and the facility.

## Electrical Options and Accessories

### **Single-Point Electrical Connection**

Provides a single power connection to the unit power block with compressor circuit breakers or to a disconnect switch with compressor circuit breakers. Either option also available without circuit breakers.

### **Multi-Point with Disconnect Switch**

Provides a disconnect switch mounted inside the power section of the control box with a through-the-door handle for each circuit and no compressor circuit breakers. Requires field-installed circuit protection.

**Phase Loss/Voltage Protection**

Phase loss with under/over voltage protection and multiple LED indication of fault type is available as a factory-installed option to guard against compressor motor burnout.

**Convenience Outlet**

10.0 amp, 115 volt Ground Fault Circuit Interruption (GFCI) outlet in control panel for servicing unit.

**Ground Fault Protection**

Protects equipment from damage from line-to-ground fault currents less than those required for conductor protection.

**High Short Circuit Current Rating (HSCCR)**

Provides control panel with high short circuit current rating with a single-point disconnect breaker switch.

**Table 34: Standard and HSCCR Panel Ratings**

Panel Type	208V / 230V	380V / 400V / 460V	575V
Standard	5kA	5kA	5kA
HSCCR	65kA	65kA	25kA

**Electronic Expansion Valve**

An electronic expansion valve is optional on 030-070 models, which have thermal expansion valves as standard.

**Unit Options and Accessories**

**Remote Evaporators**

Trailblazer® models have an evaporator shipped separately for field installation and piping to the outdoor unit. Refrigerant piping information on models with remote evaporators can be found in the current product Installation and Operation Manual, available at [www.DaikinApplied.com](http://www.DaikinApplied.com).

**Pump Packages**

The on-board, integrated chilled water pump package is available with single or dual pump configurations. See page 5 for general information, and refer to the current product Installation and Operation Manual, available on [www.DaikinApplied.com](http://www.DaikinApplied.com), for detailed information.

**Partial Heat Recovery**

Partial heat recovery (available on 075-241 models) adds optional factory-installed heat exchangers and control logic to provide hot water for many uses such as dehumidification and pre-heating water for a boiler. See page 14 for general information, and refer to the current product Installation and Operation Manual, available on [www.DaikinApplied.com](http://www.DaikinApplied.com), for detailed information.

**IBC/OSHPD Seismic Certification**

Daikin 030-241 models have been tested and certified by an independent agency — experts in seismic analysis and design — to meet IBC seismic and OSHPD pre-approval. The SDS (design spectral response acceleration at short

period) level varies by model size and other factors. The chiller must be installed with either the seismic rated springs, or the neoprene pads provided with the unit. Find more information about seismic requirements and HVAC systems at [www.DaikinApplied.com](http://www.DaikinApplied.com). Seismic option not available with select options. Contact your local sales representative for more details.

**Vibration Isolators (Field Installed)**

Spring or neoprene-in-shear vibration isolators are available for field installation to reduce vibration transmission through the unit base. Seismic rated spring isolators are available for units requiring seismic certification.

**Wind Load Rated**

AGZ-E models have been evaluated to withstand up to 186 mph winds when ordered with this option. Contact the local Daikin Applied sales representative with your specific installation requirements.

**Protective Base Guards**

Optional factory-installed, vinyl-coated, welded-wire base guards provide around lower section protection on ground level installations.

**Figure 53: Unit with Base Guards**

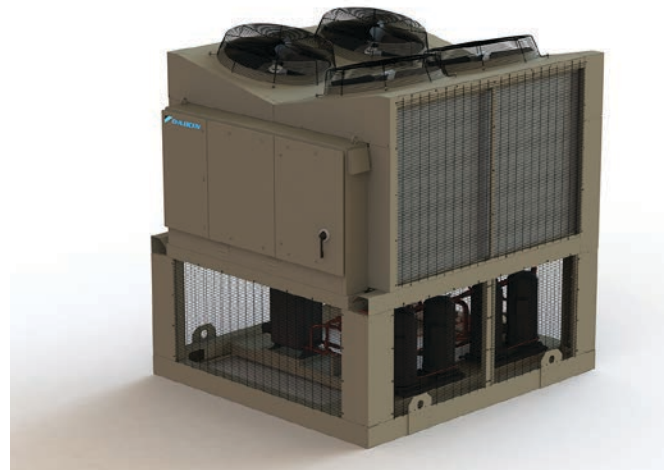

**Louvers (Base and/or Coil)**

Available for the upper portion or both the upper and lower portions of unit (upper not required on 030 and 035 models). Selecting both will completely enclose the unit with louvers. The louvers protect the coils from hail damage.

**Figure 54: Unit with Louvered Panels**



### ***Epoxy Coated Fins***

Microchannel coils coated with baked epoxy protective coating with 6000+ hour salt spray resistance (ASTM B117-90).

### ***Evaporator Insulation***

Double insulation thickness (total of 1.5 inches) for high humidity areas or low fluid temperatures.

### ***Sound Reduction***

Acoustical blankets are factory installed on each compressor. They are also available for retrofit field installation.

### ***Shut-off Valves***

Suction valves (one per circuit), liquid line shutoff valves, and discharge shutoff valves can be factory mounted.

### ***Chicago Code Relief Valves***

Unit will be provided with factory-mounted relief valves to meet Chicago code requirements.

### ***Evaporator Inlet Strainer***

Field-installed evaporator water strainer kit consisting of Y-type strainer, blowdown valve, pipe extension with two Schrader fittings and two grooved couplings. Details on page 12.

### ***Replaceable Core Filter Drier***

Factory-installed filter drier with a replaceable core allows for fast replacement of filter element and easier serviceability.

# TRAILBLAZER® AIR-COOLED SCROLL COMPRESSOR CHILLERS

## PART 1--GENERAL

### 1.01 SUMMARY

- A. Section includes design, performance criteria, refrigerants, controls, and installation requirements for air-cooled scroll compressor chillers.

### 1.02 REFERENCES

- A. Comply with applicable Standards/Codes of AHRI 550/590, ANSI/ASHRAE 15, ETL, cETL, NEC, and OSHA as adopted by the State.
- B. Units shall meet the efficiency standards of the current version of ASHRAE Standard 90.1, and FEMP Standard 2012.

### 1.03 SUBMITTALS

- A. Submit shop drawings and product data in accordance with the specifications.
- B. Submittals shall include the following:
  1. Dimensioned plan and elevation view drawings, required clearances, and location of all field connections.
  2. Single-line schematic drawing of the power field hookup requirements, indicating all items that are furnished.
  3. Schematic diagram of control system indicating points for field interface/connection.
  4. Diagram shall fully delineate field and factory wiring.
  5. Installation manuals.

### 1.04 QUALITY ASSURANCE

- A. Qualifications: Equipment manufacturer must specialize in the manufacture of the products specified and have five years experience with the type of equipment and refrigerant offered.
- B. Regulatory Requirements: Comply with the codes and standards specified.
- C. Chiller manufacturer's plant must be ISO registered.

### 1.05 DELIVERY AND HANDLING

- A. [Packaged Chillers Only: Chiller shall be delivered to the job site completely assembled and charged with refrigerant and oil by the manufacturer.] [030-070 models only: The outdoor unit shall be delivered to the job site with condensing section completely assembled and a holding charge of inert gas.
- B. Comply with the manufacturer's instructions for rigging and handling equipment.

### 1.06 WARRANTY

- A. The refrigeration equipment manufacturer's guarantee shall be for a period of one year from date of equipment start-up but not more than 18 months

from shipment. The guarantee shall provide for repair or replacement due to failure by material and workmanship that prove defective within the above period, excluding refrigerant.

### 1.07 MAINTENANCE

- A. Maintenance of the chillers shall be the responsibility of the owner and performed in accordance with the manufacturer's instructions.

## PART 2--PRODUCTS

### 2.01 ACCEPTABLE MANUFACTURERS

- A. Daikin Applied
- B. (Approved Equal)

### 2.02 UNIT DESCRIPTION

- A. Provide and install as shown on the plans factory assembled, factory-charged air-cooled packaged chillers in the quantity specified. Each chiller shall consist of hermetic dual or triple scroll compressor sets (total four or six compressors), brazed plate evaporator, air-cooled condenser section, microprocessor-based control system and all components necessary for controlled unit operation.
- B. Chiller shall be functionally tested at the factory to ensure trouble-free field operation.

### 2.03 DESIGN REQUIREMENTS

- A. General:[Packaged Chillers: Provide a complete scroll compressor packaged chiller as specified herein and as shown on the drawings. The unit shall be in accordance with the standards referenced in section 1.02 and any local codes in effect.] [030-241 remote models: Provide a complete scroll compressor chiller system consisting of an outdoor compressor-condenser section and a remote indoor evaporator as specified herein and as shown on the drawings. The unit shall be in accordance with the standards referenced in section 1.02 and any local codes in effect.]
- B. Performance: Refer to the schedule of performance on the drawings. The chiller shall be capable of stable operation to a minimum percentage of full load (without hot gas bypass) of 25%. [17% for 6 compressor units]. Performance shall be in accordance with AHRI Standard 550/590.
- C. Flow Range: The chiller shall have the ability to support variable flow range down to 40% of nominal design (based on AHRI conditions).
- D. Operating Range: The chiller shall have the ability to control leaving chilled fluid temperature from 15°F (-9°C) to 65°F (18°C).
- E. Acoustics: Sound pressure levels for the unit shall not exceed the following specified levels. The



manufacturer shall provide the necessary sound treatment to meet these levels if required. Sound data shall be provided with the quotation. Test shall be in accordance with AHRI Standard 370.

Sound Pressure (at 30 feet)											
63 Hz	125 Hz	250 Hz	500 Hz	1000 Hz	2000 Hz	4000 Hz	8000 Hz	Overall dBA	75% Load dBA	50% Load dBA	25% Load dBA

Sound Power											
63 Hz	125 Hz	250 Hz	500 Hz	1000 Hz	2000 Hz	4000 Hz	8000 Hz	Overall dBA	75% Load dBA	50% Load dBA	25% Load dBA

**2.04 CHILLER COMPONENTS**

**A. Compressors**

- The compressors shall be sealed hermetic, scroll type with crankcase oil heater and suction strainer. The compressor motor shall be refrigerant gas cooled, high torque, hermetic induction type, two-pole, with inherent thermal protection on all three phases and shall be mounted on RIS vibration isolator pads. The compressors shall be equipped with an internal module providing compressor protection and communication capability.

[Optional] Provide power factor correction capacitors for each compressor in order to raise compressor power factor to 0.95 at standard rating conditions. Capacitors shall be housed in a separate NEMA 3R rated enclosure and shall have fusing to protect the capacitors from over current. Fuse indicator lights shall be provided to provide visual indication that a fuse has blown.

**B. Evaporators**

- The evaporator shall be a compact, high efficiency, dual circuit, brazed plate-to-plate type heat exchanger consisting of parallel stainless steel plates.
- The evaporator shall be protected with an external, electric resistance heater plate and insulated with 3/4-inch (19 mm) thick closed-cell polyurethane insulation. This combination shall provide freeze protection down to -20°F (-29°C) ambient air temperature.
- The water-side working pressure shall be a minimum of 653 psig (4502 kPa). Vent and drain connections shall be provided in the inlet and outlet chilled water piping by the installing contractor. Evaporators shall be designed and constructed according to, and listed by, Underwriters Laboratories (UL).

[OPTIONAL] The evaporator shall have 1.5-inch (38 mm) closed-cell polyurethane insulation.

**C. Condenser**

- Condenser fans shall be propeller type arranged for vertical air discharge and individually driven by direct-drive fan motors. The fans shall be equipped with a heavy-gauge vinyl-coated fan guard. Fan motors shall be TEAO type with permanently lubricated ball bearings, inherent overload protection, three-phase, direct-drive, 1140 rpm.

Each fan section shall be partitioned to avoid cross circulation.

- Coil shall be microchannel design and shall have a series of flat tubes containing multiple, parallel flow microchannels layered between the refrigerant manifolds. Tubes shall be 9153 aluminum alloy. Tubes made of 3102 alloy or other alloys of lower corrosion resistance shall not be accepted. Coils shall consist of a two-pass arrangement. Each condenser coil shall be factory leak tested with high-pressure air under water.

[Standard Microchannel Coil] Coils shall withstand 1000+ hour acidified synthetic sea water fog (SWAAT) test (ASTM G85-02) at 120°F (49°C) with 0% fin loss and develop no leaks.

[Epoxy-coated Microchannel Option] Condenser coils shall include baked epoxy coating providing 6000+ hour salt spray resistance (ASTM B117-90) applied to both the coil and the coil frames.

**D. Refrigerant Circuit**

- Each of the two refrigerant circuits shall include a refrigerant filter drier, sight glass with moisture indicator, liquid line solenoid valve (no exceptions), expansion valve, and insulated suction line.

[Optional] Each of the two refrigerant circuits shall include a replaceable-core refrigerant filter drier, sight glass with moisture indicator, liquid line solenoid valve (no exceptions), expansion valve, and insulated suction line.

**E. Construction**

- Unit casing and all structural members and rails shall be fabricated of pre-painted or galvanized steel. Painted parts shall be able to meet ASTM B117, 1000-hour salt spray test.
- Options
  - Painted steel wraps enclosing the coil end sections and piping
  - Protective, 12 GA, PVC-coated, wire coil guards for the vertical upper coil section of the unit
  - Protective, 12 GA, PVC-coated, wire base guards for the lower section of the unit
  - Protective and decorative louvers for upper section of the unit, covering the coils and unit end.



- e. Protective and decorative louvers for lower section of the unit
- F. Control System
1. A centrally located weatherproof control panel shall contain the field power connection points, control interlock terminals, and control system. Box shall be designed in accordance with NEMA 3R rating. Power and starting components shall include factory circuit breaker for fan motors and control circuit, individual contactors for each fan motor, solid-state compressor three-phase motor overload protection, inherent fan motor overload protection and two power blocks (one per circuit) for connection to remote, contractor supplied disconnect switches. Hinged access doors shall be lockable. Barrier panels or separate enclosures are required to protect against accidental contact with line voltage when accessing the control system.
  2. Options
    - a. [Shall include standard multi-point power blocks.]
    - b. [Shall include single-point power connection to power block with compressor circuit breakers (Customer-supplied disconnect required).]
      - [Shall include single-point connection to a non-fused disconnect switch with through-the-door handle and compressor circuit breakers.]
    - c. [Shall include multi-point disconnect switches (one per circuit).]
    - d. [Shall include high short circuit current rating of 65,000 amps (25,000 amps at 575 Volt) with single-point disconnect switch.][Shall include multi-point disconnect switches (one per circuit).]
- G. An advanced DDC microprocessor unit controller with a 5-line by 22-character liquid crystal display provides the operating and protection functions. The controller shall take preemptive limiting action in case of high discharge pressure or low evaporator pressure. The controller shall contain the following features as a minimum:
1. Equipment Protection
    - a. The unit shall be protected in two ways: (1) by alarms that shut the unit down and require manual reset to restore unit operation and (2) by limit alarms that reduce unit operation in response to some out-of-limit condition. Shutdown alarms shall activate an alarm signal.
    - b. Shutdown Alarms:
      - No evaporator water flow
      - Sensor failures
      - Low evaporator pressure
      - Evaporator freeze protection
      - High condenser pressure
      - Outside ambient temperature (auto-restart)
  - Motor protection system
  - Phase voltage protection (Optional)
- c. Limit Alarms
- Condenser pressure stage down, unloads unit at high discharge pressures
  - Low ambient lockout, shuts off unit at low ambient temperatures
  - Low evaporator pressure hold, holds stage #1 until pressure rises
  - Low evaporator pressure unload, shuts off one compressor
- d. Unit Enable Selection
- Enables unit operation from either local keypad, digital input, or BAS
- e. Unit Mode Selection
- Selects standard cooling, ice, glycol, or test operation mode
- f. Analog Inputs
- Reset of leaving water temperature, 4-20 mA
  - Current Limit
- g. Digital Inputs
- Unit off switch
  - Remote start/stop
  - Flow switch
  - Ice mode switch, converts operation and setpoints for ice production
  - Motor protection
- h. Digital Outputs
- Shutdown alarm; field wired, activates on an alarm condition, off when alarm is cleared
  - Evaporator pump; field wired, starts pump when unit is set to start
- i. Condenser Fan Control
- The unit controller shall provide control of condenser fans based on compressor discharge pressure.
- j. Building Automation System (BAS) Interface
- Factory mounted DDC controller(s) shall support operation on a BACnet®, Modbus® or LonMark® network via one of the data link / physical layers listed below as specified by the successful Building Automation System (BAS) supplier.
  - BACnet® MS/TP master (Clause 9)
  - BACnet® IP, (Annex J)
  - BACnet® ISO 8802-3, (Ethernet)
  - LonMark® FTT-10A. The unit controller shall be LonMark® certified.
  - The information communicated between the BAS and the factory mounted unit controllers

shall include the reading and writing of data to allow unit monitoring, control and alarm notification as specified in the unit sequence of operation and the unit points list.

- For chillers communicating over a LonMark® network, the corresponding LonMark® External Interface File (XIF) shall be provided with the chiller submittal data.
- All communication from the chiller unit controller as specified in the points list shall be via standard BACnet® objects. Proprietary BACnet® objects shall not be allowed. BACnet® communications shall conform to the BACnet® protocol (ANSI/ASHRAE135-2001). A BACnet® Protocol Implementation Conformance Statement (PICS) shall be provided along with the unit submittal.

## 2.05 OPTIONS AND ACCESSORIES

The following optional items shall be furnished:

- A. RapidRestore® and Fast Loading: The chiller shall be equipped with the capability to restart and to reach full load more quickly than standard in case of a power interruption. The chiller shall be capable of rapidly restarting after power loss duration of up to 180 seconds. The time to restart the chiller shall be a maximum of 125 seconds, and full load shall be achieved in 220 seconds from power restoration.
- B. Fast Loading Stand-By Chiller: The chiller shall be equipped with the capability to start and to reach full load more quickly than standard in the event that the primary chiller system is disabled. The chiller shall be capable of rapidly achieving full capacity. The time to full load shall be achieved in 115 seconds.
- C. [075-241 models only] Partial Heat Recovery: An auxilliary brazed-plate heat exchanger shall be added in each unit refrigerant circuit between the compressors and the condenser coils. The heat exchangers shall transfer the compressor discharge gas heat to a separate water loop to be used for various heating applications. Water temperature sensors and piping connections shall be factory installed. The amount of heat produced is dependent on the requested cooling load, the operating temperatures, and the water flow rate through the auxilliary heat exchangers. Chiller controller shall supply 0-10V DC or 4-20ma signal for control of a field provided 3-way valve or pump VFD.
- D. Optional Seismic Certification: Provide chiller with seismic rating based on site SDS and importance factor levels. Seismic rating shall consist of OSHPD pre-approval for the model and configuration provided. Ensure rated SDS level is adequate for the installed location. Provide [seismic rated spring isolators] [neoprene pads] for secure mounting of the chiller to the base. Chiller shall be marked with a label showing the applicable OSHPD pre-approval number.
- E. Wind Load Rated: Evaluated to withstand wind speeds up to 186 mph. Provide engineer-stamped

certificate that equipment has been evaluated and built to meet the required wind velocity.

- F. Hot Gas Bypass: Allows unit operation to 10% of full load. Includes factory-mounted hot gas bypass valve, solenoid valve, and manual shutoff valve for each circuit. Shall be ready for field piping according to manufacturer instructions.
- G. Low Ambient Control: Fan VFD allows unit operation down to -10°F (-23°C).
- H. High ambient control box for operation in ambient temperatures from 105°F (40°C) to 125°F (52°C).
  - I. Ground Fault Protection: Factory installed circuit breaker to protect equipment from damage from line-to-ground fault currents less than those required for conductor protection.
  - J. Phase loss with under/over voltage protection and with LED indication of the fault type to guard against compressor motor burnout.
- K. Factory-mounted thermal dispersion flow switch
- L. Field-mounted, paddle type, chilled water flow switch field wired to the control panel
- M. Evaporator inlet strainer, minimum of 0.063" perforations for brazed plate evaporators with extension pipe and grooved couplings (factory mounted or field installed).
- N. Spring vibration isolators (field installed)
- O. Rubber-in-shear vibration isolators (field installed)
- P. Seismic-rated spring isolators (field installed)
- Q. Compressor sound reduction package
- R. Remote operator interface panel (field-wired)
- S. 115V GFI convenience outlet
- T. BAS interface module, factory mounted

## 2.06 OPTIONAL FACTORY-INSTALLED PUMP PACKAGE

- A. The pump package shall be factory mounted and wired on the chiller. The chiller controller shall provide a pump start/stop signal when operation is required. On dual pump systems, the chiller shall also provide automatic alternating of pump starts and duty/standby functionality. The package shall be equipped with:
  1. Single Pump Model 4380: single spring inside-seal, vertical, in-line, radially split-case pump, serviceable without breaking pipe connections. The motor and pump rotating assembly shall be serviceable without removing the pump casing from the line - OR -
  2. Dual Pumps in a Single Casting Model 4392: single-spring inside-seal vertical, in-line, radially split-case pumps, mounted in a common casing with a common inlet connection and outlet connection and including a flapper valve to prevent recirculation when only one pump is operating. An isolation valve shall be included to allow one pump to operate when the other is removed. The pumps shall be designed for duty/standby, not parallel operation.

- B. Pump package shall also be equipped with:
1. "Y" type inlet strainer
  2. Combination triple-duty outlet valve having a drip-tight discharge shutoff valve, non-slam check valve, and flow throttling valve
  3. Combination suction guide with flow stabilizing outlet vanes and stainless steel strainer with a disposable fine-mesh strainer for start-up
  4. Factory power and control wiring from the AGZ chiller to the pump package control panel
  5. Flow switch mounted and wired
  6. Interconnecting schedule 40 piping with grooved couplings
  7. Insulation of all cold surfaces

C. Pump Package Options

1. Water pressure gauges on the pump suction and discharge
2. Expansion tank with size increments from 4.4 to 90 gallons, field installed (small sizes can be factory mounted)
3. Air separator with air vent, field installed
4. Storage tanks, vertical, insulated, 150, 300, 600, 1000 gallon sizes with optional immersion heater, field installed.
5. Pump VFD for variable chilled water flow capability.

[075-241 models only] Optional Variable Frequency Drive: Flow control through the pump VFD without external pressure sensors. There shall be four selectable operating modes:

- a. Sensorless Operation
- b. **BAS Input:** The pump speed and system flow will be controlled from a customer-supplied BAS input signal.
- c. **Remote Sensor Control:** The VFD is wired to a pressure sensor mounted in the chilled water piping system. This is the standard VFD control when a sensorless VFD is not used.
- d. **Locally Selected Constant Speed Control:** Provides manual control of the pump speed, overriding any current automatic speed control.

Control software shall provide automatic speed control in variable volume systems without the need for pump mounted (internal/external) or remotely mounted differential pressure system feedback sensor. Control mode setting and minimum / maximum head and flow set-points shall be set at the factory and be user adjustable via the built-in programming interface.

## PART 3--EXECUTION

### 3.01 INSTALLATION

- A. Install in strict accordance with manufacturer's requirements, shop drawings, and contract documents.
- B. Adjust and level chiller in alignment on supports.
- C. Coordinate electrical installation with electrical contractor.
- D. Coordinate controls with control contractor.
- E. Install a required cleanable, field-supplied strainer in the chilled water return line at the evaporator inlet per the guidelines in the installation manual.

### 3.02 START-UP

- A. Provide testing and starting of machine, and instruct the Owner in its proper operation and maintenance.



**DAIKIN APPLIED AMERICAS INC.  
LIMITED PRODUCT WARRANTY  
(North America)**

Daikin Applied Americas Inc. dba Daikin Applied (“Company”) warrants to contractor, purchaser and any owner of the product (collectively “Owner”) that Company, at its option, will repair or replace defective parts in the event any product manufactured by Company, including products sold under the brand name Daikin and used in the United States or Canada, proves defective in material or workmanship within twelve (12) months from initial startup or eighteen (18) months from the date shipped by Company, whichever occurs first. Authorized replaced parts are warranted for the duration of the original warranty. All shipments of such parts will be made FOB factory, freight prepaid and allowed. Company reserves the right to select carrier and method of shipment.

In addition, labor to repair or replace warranty parts is provided during Company normal working hours on products with rotary screw compressors and centrifugal compressors. Warranty labor is not provided for any other products.

Company’s liability to Owner under this warranty shall not exceed the lesser of the cost of correcting defects in the products sold or the original purchase price of the products.

PRODUCT STARTUP ON CENTRIFUGAL AND SCREW COMPRESSOR PRODUCTS IS MANDATORY and must be performed by a Daikin Applied or a Company authorized service representative.

It is Owner’s responsibility to complete and return the Registration and Startup Forms accompanying the product to Company within ten (10) days of original startup. If this is not done, the ship date and the startup date will be deemed the same for warranty period determination, and this warranty shall expire twelve (12) months from that date.

**EXCEPTIONS**

1. If free warranty labor is available as set forth above, such free labor does not include diagnostic visits, inspections, travel time and related expenses, or unusual access time or costs required by product location.
2. Refrigerants, fluids, oils and expendable items such as filters are not covered by this warranty.
3. This warranty shall not apply to products or parts which (a) have been opened, disassembled, repaired, or altered by anyone other than Company or its authorized service representative; or (b) have been subjected to misuse, negligence, accidents, damage, or abnormal use or service; or (c) have been operated, installed, or startup has been provided in a manner contrary to Company’s printed instructions, or (d) were manufactured or furnished by others and which are not an integral part of a product manufactured by Company; (e) have been exposed to contaminants, or corrosive agents, chemicals, or minerals, from the water supply source, or (f) have not been fully paid for by Owner.

**ASSISTANCE**

To obtain assistance or information regarding this warranty, please contact your local sales representative or a Daikin Applied office.

**SOLE REMEDY**

**THIS WARRANTY CONSTITUTES THE OWNER’S SOLE REMEDY. IT IS GIVEN IN LIEU OF ALL OTHER WARRANTIES. THERE IS NO IMPLIED WARRANTY OF MERCHANTABILITY OR FITNESS FOR A PARTICULAR PURPOSE. IN NO EVENT AND UNDER NO CIRCUMSTANCE SHALL COMPANY BE LIABLE FOR INCIDENTAL, INDIRECT, SPECIAL, CONTINGENT OR CONSEQUENTIAL DAMAGES, WHETHER THE THEORY BE BREACH OF THIS OR ANY OTHER WARRANTY, NEGLIGENCE OR STRICT LIABILITY IN TORT.**

No person (including any agent, sales representative, dealer or distributor) has the authority to expand the Company’s obligation beyond the terms of this express warranty or to state that the performance of the product is other than that published by Company.

For additional consideration, Company will provide an extended warranty(ies) on certain products or components thereof. The terms of the extended warranty(ies) are shown on a separate extended warranty statement.



### ***Daikin Applied Training and Development***

Now that you have made an investment in modern, efficient Daikin Applied equipment, its care should be a high priority. For training information on all Daikin Applied HVAC products, please visit us at [www.DaikinApplied.com](http://www.DaikinApplied.com) and click on Training, or call 540-248-9646 and ask for the Training Department.

### ***Warranty***

All Daikin Applied equipment is sold pursuant to its standard terms and conditions of sale, including Limited Product Warranty. Consult your local Daikin Applied representative for warranty details. To find your local Daikin Applied representative, go to [www.DaikinApplied.com](http://www.DaikinApplied.com).

### ***Aftermarket Services***

To find your local parts office, visit [www.DaikinApplied.com](http://www.DaikinApplied.com) or call 800-37PARTS (800-377-2787). To find your local service office, visit [www.DaikinApplied.com](http://www.DaikinApplied.com) or call 800-432-1342.

This document contains the most current product information as of this printing. For the most up-to-date product information, please go to [www.DaikinApplied.com](http://www.DaikinApplied.com).

Products manufactured in an ISO Certified Facility.