



BY JOHNSON CONTROLS



***Model YVAA Air-cooled Screw Compressor Liquid Chillers
with Variable Speed Drive
Style A***

150-350 Tons
525-1225 kW
2 Compressor
50 and 60 Hz
HFC-134a

FORM 201.28-EG1 (811) 1
 Introduction..... 3
 Ratings 4
 Product Description 5
 MicroComputer Control Center..... 6
 Accessories and Options 7
 Refrigerant Piping Layout..... 11
 Application Data 12
 Physical Data - English..... 16
 Physical Data - SI..... 18
 Evaporator Options..... 20
 Dimensions 22
 Rigging Hole Locations 24
 Isolator Locations..... 28
 Isolator Details..... 32
 Electrical Data..... 36
 Power Wiring..... 42
 Customer Control Wiring..... 43
 Control Wiring..... 44
 Guide Specifications 46
 Unit Conversion..... 52

NOMENCLATURE

YVAA 021 3AXX 46 AA

<p>1 2 3 4 BASE PRODUCT TYPE</p> <p>Y V A A</p> <ul style="list-style-type: none"> : York : Variable Speed Screw : Air cooled : Design Series 	<p>5 6 7 FRAME SIZE</p> <p># # #</p>	<p>8 9 10 11 CONFIGURATION</p> <p># # # #</p> <ul style="list-style-type: none"> : Condenser code : Evaporator code : Compressor code : Condenser fan & sound kit code 	<p>12 13 VOLTAGE</p> <p>1 7 : 200 / 3 / 60 2 8 : 230 / 3 / 60 4 0 : 380 / 3 / 60 4 6 : 460 / 3 / 60 5 0 : 380-415 / 3 / 50 5 8 : 575 / 3 / 60</p>	<p>14 15 LEVEL / REFRIGERANT</p> <p># A</p> <ul style="list-style-type: none"> : Development Level : Refrigerant R134a
--	---	---	---	---



Products are produced at a facility whose quality-management systems are ISO9001 certified.



ASHRAE 90.1 Compliant



JOHNSON CONTROLS

Introduction



For over 135 years, Johnson Controls has raised the bar of chiller design and customer expectations. We are raising the bar again with a leap forward in air-cooled chiller technology. Continuing the history of innovation in both compressor design and Variable Speed Drive (VSD) technology, Johnson Controls proudly introduces the YORK® YVAA.

In the past, the choice to use an air-cooled chiller came with the expectation of compromise, where simplicity of design and maintenance were traded for performance and efficiency. The new YVAA provides a better balance by combining the best of both - a high performance design that minimizes the total cost of ownership.

YORK YVAA model air-cooled chillers provide superior performance. Higher efficiency heat exchangers coupled with variable speed operation and smart controls elevate the system efficiency to a whole new level. The resulting benefit from YVAA chillers is much greater than the sum of its parts.

Efficiency: Reduce your consumption

YVAA chillers are Johnson Controls' most efficient air-cooled chillers. The design offers a lighter, smaller and quieter package that minimizes the installed cost and maximizes usable building space. YVAA chillers are simpler in design with easy access to service components for reliable operation and efficient maintenance. With up to a 40% improvement in real world efficiency versus current products, YVAA sets the new standards for lowering energy use.

Sustainability: Improve your environmental footprint

YVAA lowers both direct and indirect impact on the environment. It uses R134a refrigerant which has zero ozone

depletion potential (ODP). The design minimizes the quantity of refrigerant used in the system. Every YVAA model helps LEED projects earn the Energy and Atmosphere Credit 4. The highest portion of green house gases is carbon dioxide generated from electric power plants. HVAC systems are one of the largest consumers of electricity in commercial buildings. YVAA chillers reduce the electricity usage, thereby contributing to reducing greenhouse gases and helping keep the planet cool.

Low Sound: Quiet operation makes you a good neighbor

The variable speed technology on YVAA allows unparalleled low sound levels at off peak design conditions. This makes YVAA a great solution for sound sensitive zones. Several acoustic attenuation options such as smart controls (SilentNight™), aerodynamic fans, and effective sound enclosures allow the chiller to meet even the most stringent sound level requirements.

Confidence: Proven performance provides peace of mind

YVAA design is proven by years of success with the previous generation of YORK VSD air-cooled screw chillers with thousands of machines operating in more than one hundred countries.

YVAA is configurable to be the perfect fit for your unique needs. YVAA offers an array of options that can be tailored and tuned to match the capacity, efficiency, sound and footprint for your specific application. Several variations of condenser fans, evaporator arrangements, sound kits, protection enclosures, and controls schemes are available to meet specific requirements for your site.

Ratings



Rated in accordance with the latest issuance of AHRI Standard 550/590.

AHRI CERTIFICATION PROGRAM

The performance of the YORK YVAA chiller has been certified to the Air Conditioning, Heating, and Refrigeration Institute (AHRI) as complying with the certification sections of the latest issue of AHRI Standard 550/590. Under this Certification Program, chillers are regularly tested in strict compliance with this Standard. This provides an independent, third-party verification of chiller performance.

COMPUTERIZED PERFORMANCE RATINGS

Each chiller is custom-matched to meet the individual building load and energy requirements. A variety of standard heat exchangers and pass arrangements are available to provide the best possible match.

It is not practical to provide tabulated performance for each combination, as the energy requirements at both full and part load vary significantly with each heat exchanger and

pass arrangement. Computerized ratings are available through each Johnson Controls sales office. Each rating can be tailored to specific job requirements, and is part of the AHRI Certification Program.

OFF-DESIGN PERFORMANCE

Since the vast majority of its operating hours are spent at off-design conditions, a chiller should be chosen not only to meet the full load design, but also for its ability to perform efficiently at lower loads. It is not uncommon for chillers with the same full load efficiency to have an operating cost difference of over 10% due to differences in off-design (part-load) efficiencies.

Part load information can be easily and accurately generated by use of the computer. And because it is so important to an owner's operating budget, this information has now been standardized within the AHRI Certification Program in the form of an Integrated Part Load Value (IPLV), and Non-Standard Part Load Value (NPLV).

The current IPLV/NPLV rating from AHRI Standard 550/590 much more closely tracks actual chiller operation, and provides a more accurate indication of chiller performance than the previous IPLV/APLV rating. A more detailed analysis must take into account actual building load profiles, and local weather data. Part load performance data should be obtained for each job using its own design criteria.

Product Description

SEMI-HERMETIC YORK TWIN SCREW COMPRESSORS

The direct-drive, semi-hermetic rotary twin-screw compressors incorporate advanced technology in a rugged design. The continuous function, microprocessor controlled VSD provides smooth capacity control from 100% down to 10% of chiller capacity. State-of-the-art technology, obtained from decades of screw compressor design and manufacturing by FRICK®, ensures optimal efficiencies at all chiller load points. With no unloading steps or slide valves in the compressors, the YVAA variable speed driven compressors have 50% fewer moving parts than fixed speed compressors with slide valves. The YVAA compressor is one of the most efficient and reliable screw compressors in the industry.

EVAPORATOR

The evaporator is a shell and tube, hybrid falling film type heat exchanger. It contains a balance of flooded and falling film technology to optimize efficiency, minimize refrigerant charge, and maintain reliable control. A specifically designed distribution system provides uniform refrigerant flow for optimum performance.

CONDENSER

The YVAA introduces the microchannel coil to the YORK screw compressor chiller line. Microchannel coils are made of a single material to avoid galvanic corrosion due to dissimilar metals. Coils and headers are brazed as one piece, minimizing leaks. The inherently rugged coil construction, which includes non-overhanging fins, eliminates the possibility of fin damage. The microchannel maximizes condenser heat transfer, resulting in a smaller footprint, and reduces refrigerant charge by as much as 50%.

The condenser fans are composed of corrosion resistant aluminum hub and glass-fiber-reinforced polypropylene composite blades molded into a low-noise airfoil section. All blades are statically and dynamically balanced for vibration-free operation. Fan motors are Totally Enclosed Air-Over (TEAO), squirrel-cage type and current protected. The direct drive motors feature double-sealed and permanently lubricated ball bearings, cutting down on maintenance cost over the life of the unit.

REFRIGERANT CIRCUIT

The YVAA has one independent refrigerant circuit per compressor. Each circuit uses copper refrigerant pipe formed on computer-controlled bending machines. By using computer-aided technology, over 60% of system

pipework brazed joints have been eliminated (as compared to designs that use fittings), resulting in a highly reliable and leak-resistant system.

COMPLETE FACTORY PACKAGE

Each unit is shipped as a complete factory package, completely assembled with all interconnecting refrigerant piping and internal wiring and ready for field installation. Prior to shipment, each individual chiller undergoes an extensive testing procedure, ensuring workmanship is the highest quality and that the initial start-up is trouble-free. Before leaving the factory, each refrigerant circuit is factory pressure tested, evacuated and then fully charged with R134a refrigerant and oil. An operational test is performed with water flowing through the evaporator to ensure each circuit functions correctly.

ELECTRICAL

All controls and motor starting equipment necessary for unit operation are factory wired and function tested. There are no surprises when you go to start-up; you can have confidence that the unit will start up right the first time and every time.

The chillers come with a single point power connection and are supplied with a factory mounted and wired control transformer that powers all unit controls from the main unit power supply. The transformer utilizes scheduled line voltage on the primary side and provides 115V/1Ø on secondary. The standard unit is equipped with terminal block electrical connections. All exposed power wiring is routed through liquid-tight, UV-stabilized, non-metallic conduit.

VSD Power/Control Panel includes main power connection(s), VSD and fan motor contactors, current overloads, and factory wiring. All display and control features can be accessed through the keypad and control display access door, eliminating the need to open the main cabinet doors.

BUILDING AUTOMATION SYSTEM CAPABILITIES

The E-Link Gateway provides an economical and versatile connection between Johnson Controls equipment and open/standard protocols. It efficiently manages the communication protocols currently used by Johnson Controls equipment, exposing the data in a consistent, organized, and defined fashion. A simple switch selection allows configuration of the required equipment profile and output protocol, which reduces equipment connectivity startup time.

MicroComputer Control Center

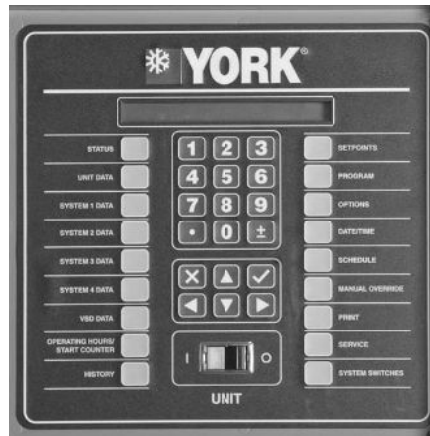

FIG.1 – VIEW OF YORK CONTROL CENTER KEYPAD AND DISPLAY

MICROCOMPUTER CONTROL CENTER

The microcomputer control center (see Figure 1) provides automatic control of chiller operation including compressor start/ stop and load/unload anti-recycle timers, condenser fans, chilled liquid pump, evaporator heater, unit alarm contacts and run signal contacts. The microcomputer control center comes online as soon as the main power switch on the unit is switched on; immediately, the micro-computer control center will begin to continuously monitor all variables.

The microprocessor controls the unit's capacity by matching the actual leaving chilled liquid temperature (LCHLT) to the user-defined setpoint. Factors that may cause the system's actual LCHLT to fluctuate are changes in ambient temperature, load, and chilled liquid loop flow rate and volume. The controls system reacts to such changes by adjusting the number of compressors that are on and the loading of each compressor in order to keep the LCHLT at the setpoint.

The controls system logic monitors the rate at which the LCWT is approaching the setpoint to ramp up or down compressor capacity as required. The variable frequency drive allows the compressor capacity to match the load.

Display Data

- Leaving Chilled Liquid Temperature
- Returning Liquid Temperature
- Ambient Temperature
- Lead System
- Compressor Capacity (% of Full Load Amps)
- VSD Output Frequency / Compressor Speed
- Compressor Run Hours
- Compressor Number of Starts
- Oil Pressure and Temperature (per Compressor)
- Chilled Liquid Pump Status

- Evaporator Heater Status
- History Data for Last Twenty Normal Shutdowns
- History Data for Last Ten Shutdown Faults

Programmable Setpoints

- Chiller on/Off
- Chilled Liquid (Water or Glycol)
- Local or Remote Control
- Units of Measure (Imperial or SI)
- System Lead/Lag
- Remote Temperature Reset
- Remote Current Limit
- Leaving Chilled Liquid Temperature Setpoint and Range

Johnson Controls' systems or another vendor's systems can incorporate these setpoints and data outputs to give the customer a complete understanding of how the system is running through a Building Automation System.

Extreme Conditions - During extreme or unusual conditions (i.e. blocked condenser coils, ambient above scheduled maximum, etc.) the chiller control system will avoid shutdown by varying capacity. By monitoring motor current and suction and discharge pressures, the chiller can maintain maximum available cooling output without shutting down.

Unit Safeties are provided for the chiller to perform auto-reset shut down for the following conditions:

- Ambient temperature above or below allowable range
- Out of range leaving chilled liquid temperature
- Under voltage
- Flow switch operation

Accessories and Options

All options factory mounted unless otherwise noted.

SOUND ATTENUATION

LOW NOISE KITS – The standard chiller configuration is equipped with low sound fans and acoustic treatments on the refrigerant lines and compressors. There are several sound attenuation options available to further reduce sound at its source thereby meeting local sound level regulations.

SilentNight - Due to time of day based sound regulations in some locations it may be desirable to force the chiller to a lower sound level on demand. The SilentNight control option provides a control input to limit sound output of the chiller based on time of day. This feature is programmable at the chiller panel or can be controlled remotely via a signal (4-20mA or 0-10 VDC) from a BAS system.

ULTRA QUIET FANS – The chiller is equipped with specially designed fans and motors to provide lower sound levels yet retain appropriate airflow. The result is reduced fan generated sound with minimal effect on the chiller capacity or efficiency at standard AHRI conditions. The fans are three-bladed for 60Hz and five-bladed for 50Hz.

FAN OPTIONS

HIGH STATIC FANS - (380V/60 Hz, 460V/60 Hz, 400V/50 Hz) The chiller is equipped with condenser fans with higher power motors suitable for high external static pressure, up to 100Pa (0.4 in. water), across condenser coils. This option should be selected if additional airflow resistance may be present due to flow restrictions such as field installed ducts, filters, sound enclosures etc. Please contact your local Johnson Controls representative for more information.

HIGH AIRFLOW FANS - (380V/60 Hz, 460V/60 Hz, and 400V/50 Hz) The chiller is equipped with condenser fans with airfoil type blades and high power motors providing extra airflow across coils. In some chiller configurations, this option can provide an increase in chiller capacity at high ambient. Please contact your local Johnson Controls representative for more information.

CONDENSER COIL PROTECTION

The aluminum alloys used in the YVAA microchannel condenser have been carefully selected and tested for high corrosion resistance. However, all metals can cor-

rode in harsh conditions. Consider protecting coils from corrosive environments such as coastal, marine, urban and industrial.

POST-COATED EPOXY DIPPED CONDENSER – Micro-channel condenser coils applied with electro-deposited and baked flexible epoxy coating that is finished with a polyurethane UV resistant top-coat suitable for highly corrosive applications.

PROTECTIVE CHILLER PANELS

WIRE PANELS – UV stabilized black polyvinyl chloride coated, heavy gauge, welded wire mesh guards mounted on the exterior of the full unit. Protects condenser coil faces and prevents unauthorized access to refrigerant components (compressors, pipes, evaporator, etc.), yet provides free air flow. This can cut installation cost by eliminating the need for separate, expensive fencing. See Figure 2.

LOUVERED PANELS – Louvered panels, painted the same color as the unit, enclose the unit to visually screen and protect the coils as well as prevent unauthorized access to internal components. Also available as a condenser-only option. See Figures 3 and 4.

LOUVERED/WIRE PANELS COMBINATION - Louvered panels, painted the same color as the unit, are mounted on external condenser coil faces. Heavy gauge, welded wire-mesh panels, coated to resist corrosion, are mounted around base of machine to restrict unauthorized access. See Figure 5.

END HAIL GUARD – Louvered panels, painted the same color as the unit, are installed on the rear of the unit (opposite end of the control panel) to protect the exposed condenser from flying debris or hail. See Figure 6.

V-GUARD PANELS – Solid panels, painted the same color as the unit, are installed along the sides of the units to cover exposed piping within the condenser section without impacting airflow. These guard panels can be combined with End Hail Guard option for additional protection from debris. See Figure 7.

Accessories and Options - continued

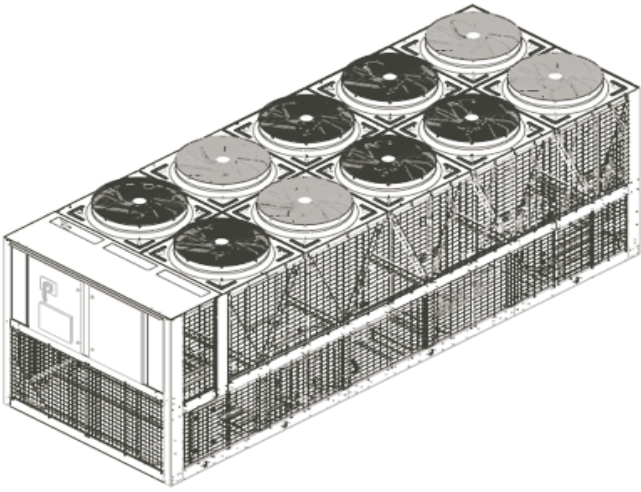

FIG. 2 – FULL UNIT WIRE PANELS

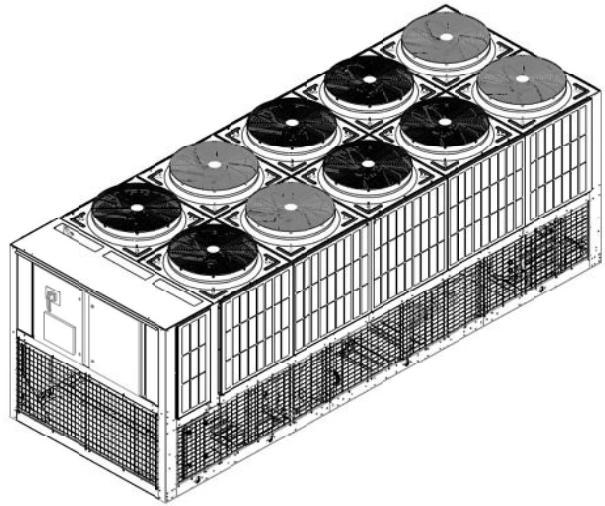

FIG. 5 – LOUVERED/WIRE PANELS COMBINATION

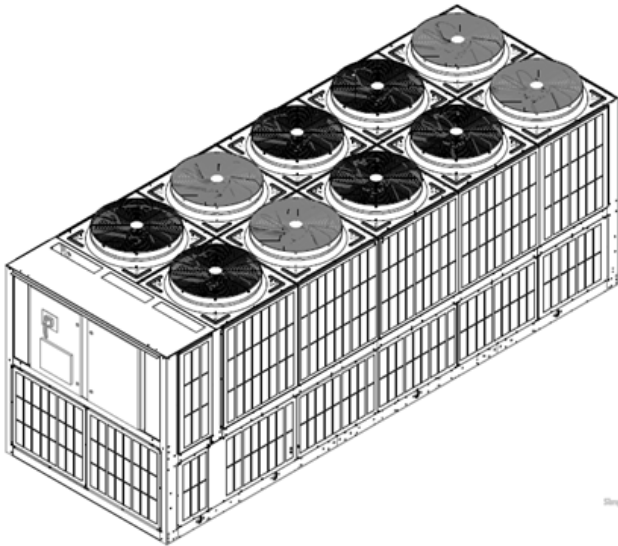

FIG. 3 – FULL UNIT LOUVERED PANELS

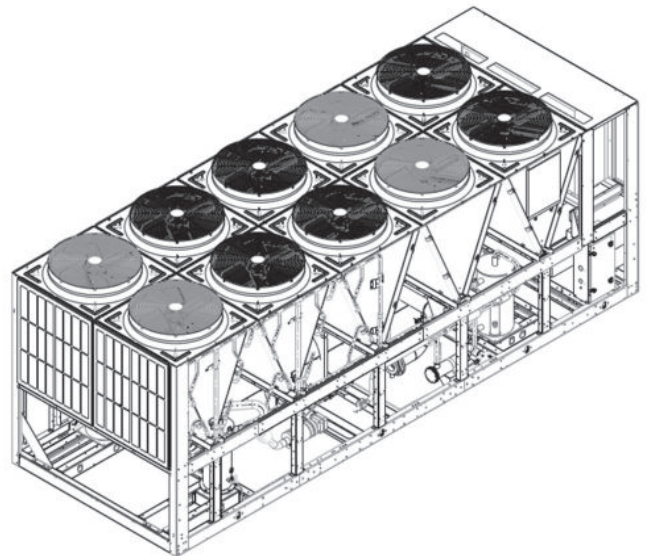

FIG. 6 – END HAIL GUARD

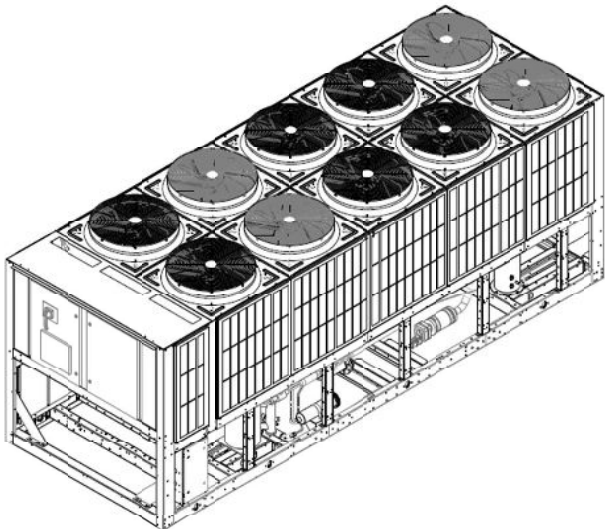

FIG. 4 – CONDENSERS-ONLY LOUVERED PANELS

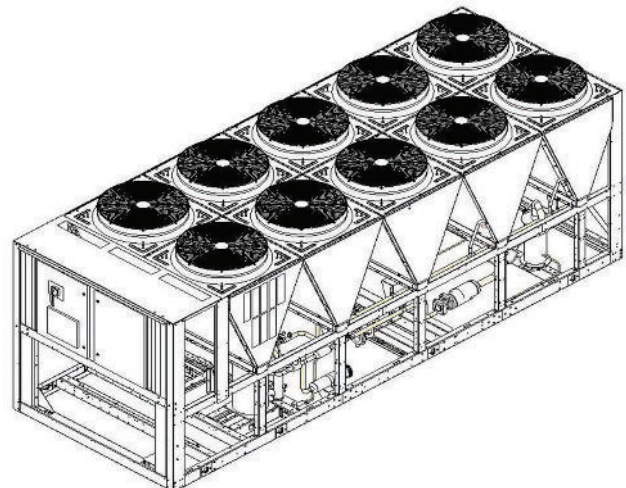

FIG. 7 – V-GUARD OPTION

EVAPORATOR OPTIONS

1-1/2" INSULATION – Double thickness insulation provided.

FLANGE KIT – Provides contractor with the couplings best suited to tie into the chilled liquid piping. All flanges are ANSI 150 psig (10.3 barg). **Field mounted.** Options include:

- **ANSI/AWWA C-606 flanges** - 2 flanges, for applications where field piping has existing flanges.
- **ANSI/AWWA C-606 flanges** - 4 flanges, for applications where customer wants flanged connections which do not exist on the field piping.
- **Weld flanges** - 2 flanges, for customer to weld to evaporator to mate to existing flanges on field piping.
- **Weld flanges** - 4 flanges, for customer to weld to evaporator and customer wants flanged connections which do not exist on the field piping

CONNECTION LOCATION - The standard unit configuration is available with liquid inlet connections at rear (opposite control panel end) of unit. Option available for front fluid inlet on select configurations.

THREE-PASS – The standard evaporator is constructed with two chilled water passes through the evaporator. The three-pass option is recommended for use in brine applications or where a greater water temperature difference is required but efficiency cannot be sacrificed.

WATER BOX HEATER - The standard unit comes with freeze protection on the evaporator down to 0°F (-17.8°C). The waterbox heater option provides additional freeze protection down to -20°F (-28°C).

CONTROLS OPTIONS

HIGH AMBIENT OPERATION – (400V/50Hz and 380V/60Hz only) This provides special control logic coupled with high airflow fans to permit high ambient (up to 125°F (52°C)) operation. This option may also allow for increased machine capacity, allowing the selection of a smaller chassis to meet specific capacity requirements.

BUILDING AUTOMATION SYSTEM INTERFACE (TEMPERATURE) - Factory installed option to accept a 4 to 20 mA or a 0 to 10 VDC input to allow remote reset of the Leaving Chilled Liquid Temperature Setpoint. The setpoint can be positively offset upwards up to 40°F (22.2°C). This option is useful for ice storage or process applications or for periods where higher chilled liquid temperatures are adequate for low loads. Available alone or in combination with BAS Load Limit.

BUILDING AUTOMATION SYSTEM INTERFACE (LOAD LIMIT) - Factory installed option to accept a 4 to 20 mA or a 0 to 10 VDC input to allow remote reset of the Load Limit Setpoint. The setpoint can limit system demand from 30-100%. Available alone or in combination with BAS Temperature Reset.

E-Link – The E-Link gateway provides full communication to Building Automation Systems, including BACnet (MS/TP), Modbus, LON and N2.

THERMAL STORAGE – Provides special control logic and modifications to produce leaving chilled brine temperatures below 40°F (4.4°C) primarily at times of low ambient temperatures (night time). Option can be used to produce ice to supplement cooling and significantly decrease energy costs. The capability of the chiller is enhanced by using both ice and chilled liquid simultaneously during times of peak cooling needs.

GENERAL OPTIONS

FLOW SWITCH ACCESSORY - Vapor proof SPDT, NEMA 3R switch, 150 psig (10.3 barg) DWP, -20°F to 250°F (-29°C to 121°C) with 1" NPT (IPS) connection for upright mounting in horizontal pipe (This flow switch or equivalent must be furnished with each unit). **Field mounted.**

DIFFERENTIAL PRESSURE SWITCH – This 3-45 psig (0.2-3 barg) range switch, with 1/4" NPTE pressure connections, is an alternative to the paddle-type flow switch. **Field mounted.**

SERVICE ISOLATION VALVE – Service suction isolation valve added to unit for each refrigerant circuit.

CHICAGO CODE RELIEF VALVE - Special relief valves per Chicago code.

DUAL PRESSURE RELIEF VALVE – Two safety relief valves are mounted in parallel; one is always operational to assist in valve replacement during maintenance.

PRESSURE VESSEL OPTIONS – The evaporator can be provided with either ASME or PED pressure vessel codes certification.

CIRCUIT BREAKER – A unit-mounted circuit breaker with external lockable handle will be supplied to isolate the single point power voltage for servicing. The circuit breaker is sized to provide motor branch circuit protection, short circuit protection and ground fault protection for the motor branch-circuit conductors, the motor control apparatus and the motors.

Accessories and Options - continued

NON-FUSED DISCONNECT SWITCH – Unit-mounted disconnect switch(es) with external lockable handle can be supplied to isolate the unit power voltage for servicing. Separate external fusing must be supplied by the power wiring, which must comply with local codes.

SPECIAL REQUIREMENT DOCUMENTS – There are two options to select from:

- Special Requirement Document Package (SRDP) includes Pressure Vessel Report, Unit Run Test Report, Production System Check Sheet and Final Unit Inspection Check Sheet.
- Materials Package includes steel mill material reports for vessels in addition to the SRDP.

VIBRATION ISOLATION

ELASTOMERIC ISOLATION – This option is recommended for normal installations. It provides very good performance in most applications for the least cost. **Field mounted.**

1" SPRING ISOLATORS – Spring and cage type isolators for mounting under the unit base rails are available to support unit. They are level adjustable. 1" nominal deflection may vary slightly by application. **Field mounted.**

2" RESTRAINED SPRING ISOLATORS – Restrained Spring-Flex Mounting isolators incorporate a rugged welded steel housing with vertical and horizontal limit stops. Housings designed to withstand a minimum 1.0g accelerated force in all directions up to 2" (51mm). The deflection may vary slightly by application. They are level adjustable. **Field mounted.**

Refrigerant Piping Layout

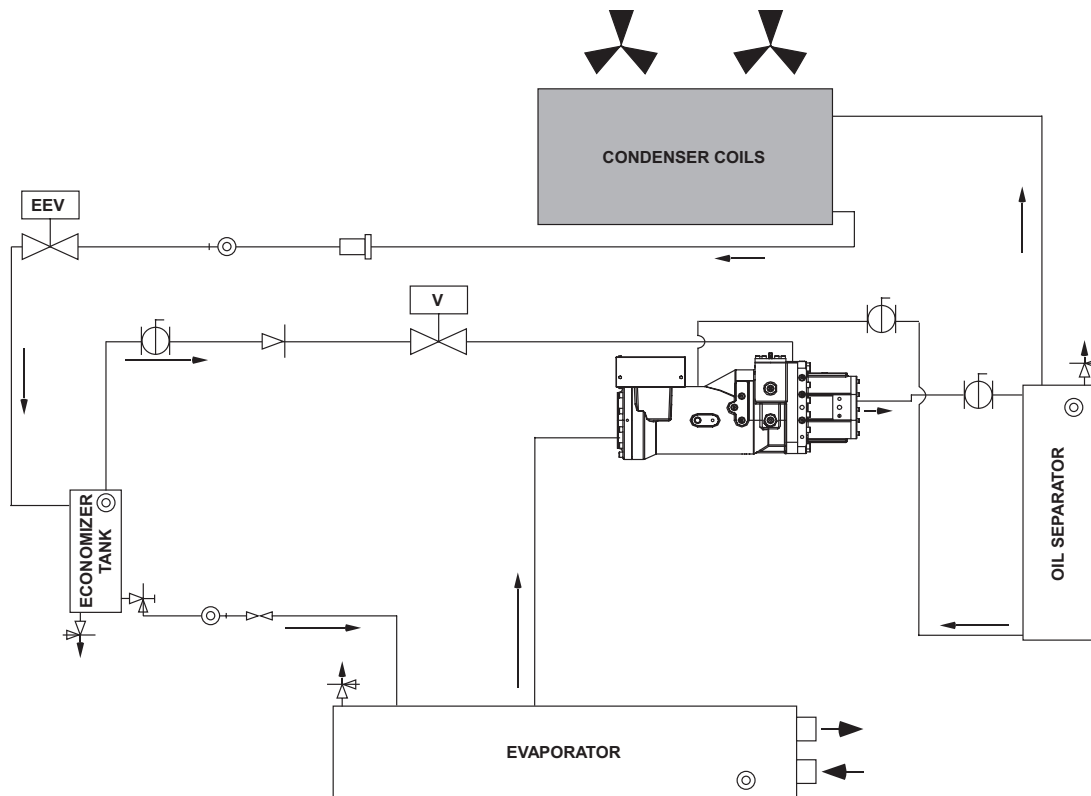

Symbol	VVAA System Component
	Electronic Expansion Valve
	Ball Valve
	Relief Valve
	Stop Valve Angle, Access
	Replaceable Core Filter/Dryer
	Sight Glass
	Orifice
	Check Valve
	Valve

Low pressure refrigerant (liquid and gas) enters the evaporator and is sprayed across the top of the tube bundle from spray nozzles. The liquid refrigerant from the nozzles gravity drains down across the tube bundle and is evaporated and superheated by the heat energy absorbed from the chilled liquid passing through the tubes.

The low pressure refrigerant vapor leaves the top of the evaporator and enters the compressor where the refrigerant vapor is compressed and the pressure and superheat are increased. The high pressure superheated gas enters the air cooled condenser where heat is rejected via the condenser coils and fans.

The fully condensed and sub-cooled liquid leaves the air cooled condenser, flows through the filter drier and enters the economizer tank. The flow of refrigerant into the economizer is controlled by the electronic expansion valve.

Additional cooling of the refrigerant liquid may take place in the economizer tank when the economizer valve is opened. After leaving the economizer tank, liquid refrigerant flows through an orifice where pressure reduction and further cooling take place. The low pressure refrigerant (liquid and gas) then enters the evaporator.

Application Data

UNIT SIZING

Avoid over-sizing a chiller. Properly sized chillers operate stably and provide the best life cycle cost. When designing phased projects, select multiple small chillers to match demand for each phase. Use multiple small chillers when the minimum cooling demand is less than 10% of the maximum cooling demand.

UNIT LOCATION

The YVAA chillers are designed for outdoor installation. To achieve optimum performance and trouble-free service provide adequate space around chillers (see Figure 8). When selecting chiller installation sites, follow these requirements:

1. Installation sites may be either on a roof or on ground level. (See **FOUNDATION**)
2. Provide space for air to flow into condensers per dimensions shown on the dimension drawing on pgs 20 and 21. Restricted airflow or hot air recirculation will diminish performance. Johnson Controls' unit controls will optimize the operation without nuisance high pressure safety cutouts; however, the system designer **MUST** consider potential performance degradation. Recommended clearances (See Fig. 8) for all units are as follows:
 - a. Access to the unit control center stipulates the unit is no higher than on spring isolators.
 - b. Recommended minimum clearances:
 - i. Side to wall – 6' (1.8m)
 - ii. Rear to wall – 6' (1.8m)
 - iii. Control panel end to wall – 4' (1.2m)
 - iv. Top – no obstructions whatsoever
 - v. Distance between adjacent units – 10' (3m)
 - c. No more than one wall around the chiller yard should be higher than the chiller(s)
3. Avoid locations near windows or structures where normal operating sounds may be objectionable.
4. The condenser fans are propeller-type and are not recommended for use with ductwork, filters or other impediments to airflow in the condenser air stream.
5. When obstructions to airflow exist, they must not add more than 0.1" external static pressure.
6. Protection against corrosive environments is available by ordering the units with cured epoxy-coating on the condenser microchannel. Epoxy-coated coils should be used with any units being installed at the seashore, or where salt spray may hit the units, or where acid rain is prevalent.
7. On installations where winter operation is intended and snow accumulations are expected, additional elevation must be provided to insure normal condenser air flow.

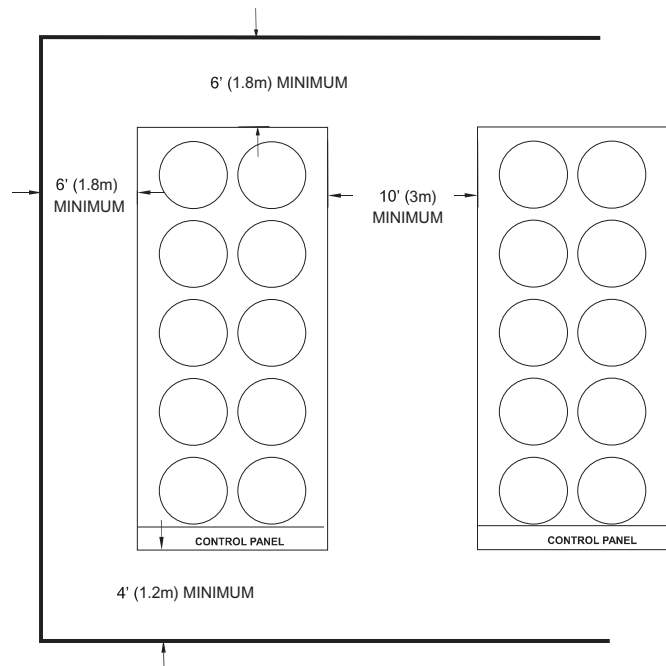

FIG 8. – ACCEPTABLE MINIMUM CLEARANCES AROUND/BETWEEN UNIT(S) FOR PROPER AIRFLOW

8. Provide adequate space for tubes to be removed from evaporator. For clearances please contact your nearest Johnson Controls Sales Office.

FOUNDATION

Mount units on a flat and level foundation, ground or roof, capable of supporting the entire operating weight of the equipment. Please contact your nearest Johnson Controls Sales Office for shipping and operating weights.

Roof Locations – Provide structure to safely support the entire weight of the unit and service personnel. Do not damage the roof during installation. If the roof is “bonded”, consult a building contractor or architect for special installation requirements. Use spring isolators to minimize vibration transmission into building structure. Provide additional structural support at the spring-isolator locations.

Ground Locations – Units must be installed on a substantial base that will not settle and cause strain on the refrigerant lines, resulting in possible leaks. A one-piece concrete slab, with footers extending below the frost line is recommended. The slab should not be tied to the main building foundation as operational noise will telegraph. Mounting holes (5/8”) are provided in the base rails for bolting the unit to its foundation. See **ISOLATOR LOCATIONS** on page 54 for location of the mounting holes.

For ground installations, precautions should be taken to protect the unit from tampering by, or injury to, unauthorized persons. Fasteners on access panels will prevent

casual tampering; however, further safety precautions such as unit enclosure options, a fenced-in enclosure, or locking devices on the panels may be advisable. Check local authorities for safety regulations.

Seismic Applications – Avoid installing chillers on springs or roofs where earthquakes are a risk. Springs and roofs amplify earthquake forces. Rigidly mounting chillers to ground level concrete pads is typically the best option for earthquake zones. Contact Johnson Controls equipment specialists for help with projects that have seismic requirements.

CHILLED LIQUID PIPING

Design the chilled liquid piping system so that the circulating pump discharges into the evaporator. The inlet and outlet evaporator-liquid connections are given in **DIMENSIONS**. Hand stop valves are recommended in all lines to facilitate servicing. Provide drain connections at low points to permit complete drainage of the evaporator and system piping.

The evaporator must be protected by a strainer, preferably of 40 mesh, fitted as close as possible to the liquid inlet connection, and provided with a means of local isolation.

The evaporator must not be exposed to flushing velocities or debris released during flushing. It is recommended that a suitably sized bypass and valve arrangement is installed to allow flushing of the piping system. The bypass can be used during maintenance to isolate the heat exchanger without disrupting flow to other units.

Pressure-gauge connections are recommended for installation in the inlet and outlet liquid lines. Gauges are not provided with the unit and are to be furnished by others. Chilled liquid lines exposed to the weather should be wrapped with a supplemental heater cable and insulated, or glycol should be added to the chilled liquid to protect against freezing if low-ambient periods are expected.

A flow switch is available as an accessory on all units. A flow switch must be installed in the leaving liquid piping of the evaporator and must not be used to start and stop the unit.

MINIMUM LIQUID VOLUME

It is good practice to include as much liquid volume as possible in a chilled liquid loop. This increases the thermal mass and “Flywheel” effect within the system (i.e. the more the better) which in turn promotes stable liquid temperature control and increases reliability by reducing compressor cycling.

For air conditioning applications, a minimum of 3 gallons/ton (3.2 liters/cooling KW) is recommended. It is preferred

that the gallon/ton ratio be within the 5 to 8 (5.4 to 8.6 liter/cooling KW) range for constant flow rate chilled liquid systems. See **VARIABLE PRIMARY FLOW** for recommendations for VPF systems. For process applications, a minimum of 6 gallons/ton (6.5 liter/cooling KW) ratio is recommended with preference towards a range of 7 to 11 (7.5 to 11.8). Install a tank or increase pipe sizes to provide sufficient liquid volume.

LEAVING LIQUID TEMPERATURE OUT OF RANGE

The YVAA chiller line has a maximum leaving liquid temperature of 60°F (15.6°F). Some process applications require a chilled liquid temperature higher than what the chiller provides. In those applications, a simple piping change can remove the problem. By using a mixture of chiller-cooled liquid and returning process liquid, the chilled liquid entering the process can be held at the desired temperature. (A tank can also be used to meet high leaving liquid temperature requirements.) (See Figure 9)

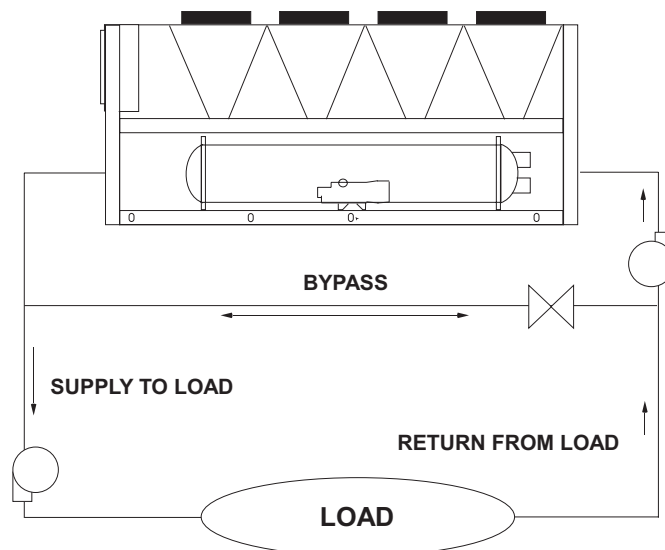

FIG. 9 – LEAVING LIQUID TEMPERATURE OUT OF RANGE SUGGESTED LAYOUT

FLOW RATE OUT OF RANGE

Each YVAA evaporator has a minimum and maximum flow rate. Some process applications require a flow rate that is out of range for the evaporator. In those applications, a piping change can remove the problem.

In applications where the required flow rate is less than the evaporator's minimum allowable, the chilled liquid can be recirculated to the chiller. (See Figure 10, pg 14)

In applications where the required flow rate is greater than the evaporator's maximum allowable, the chilled liquid can be recirculated to the load (see Figure 11, pg 14).

Application Data - continued

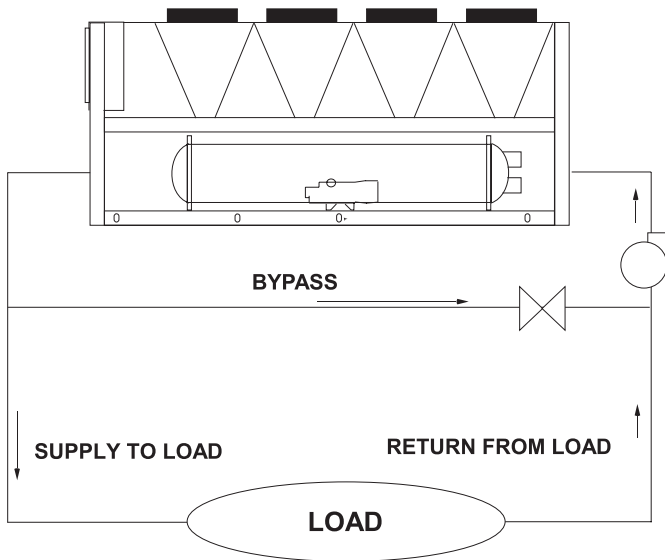

FIG. 10 – SUGGESTED LAYOUT FOR APPLICATIONS WITH A FLOW RATE LESS THAN THE EVAPORATOR MINIMUM ALLOWABLE FLOW RATE

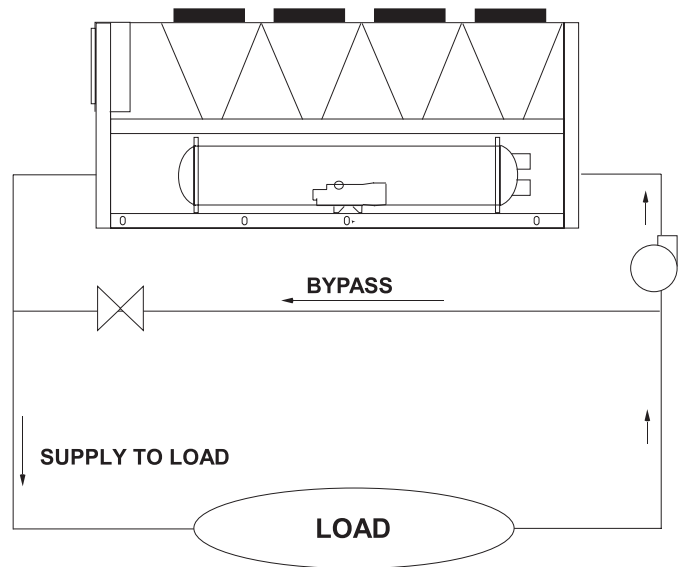

FIG. 11 – SUGGESTED LAYOUT FOR APPLICATIONS WITH A FLOW RATE GREATER THAN THE EVAPORATOR MAXIMUM ALLOWABLE FLOW RATE

THERMAL STORAGE

Thermal storage is the practice of storing cooling energy during a period of little or no load and/or low energy costs for use during periods of high load and/or energy costs. Conventional cooling systems produce cooling when it is needed which is commonly during times of peak demand. Thermal storage allows generation of cooling capacity to occur during off-peak periods and store that capacity to meet future cooling requirements. Using thermal storage can result in smaller equipment sizes, thereby reducing capital cost, and also can result in significant energy cost savings.

The YVAA has special control logic to be able to produce chilled leaving brine temperatures below 40°F (4.4°C) so as to supply a storage tank with chilled liquid during times of low demand. YVAA chillers selected for thermal storage operation can also be selected to efficiently provide chilled liquid at nominal cooling loads.

VARIABLE PRIMARY FLOW

Johnson Controls recommends a maximum 10% per minute flow rate of change, based on design flow, for variable primary flow applications. Eight to 10 gallons per chiller ton (8.6 to 10.8 liter per cooling KW) is recommended for the system liquid volume. Insufficient system volume and rapid flow changes can cause control problems or can even cause chiller shutdowns. There are many other design issues to evaluate with variable primary flow systems. Consult your Johnson Controls Sales Office for more information about successfully applying YVAA chillers.

INTENTIONALLY LEFT BLANK

Physical Data - English

The data shown in this table is applicable to selected typical configurations. Other configurations are available through our configuration/selection software. Please contact your nearest Johnson Controls Sales Office for the chiller configuration that best matches your specific needs.

UNIT FRAME	015	016	017	018	019	019	020	021	021	021	023	024	024
CONDENSER CODE	3	5	8	3	5	8	0	3	5	8	3	5	8
EVAPORATOR CODE	B	B	C	A	A	B	C	A	C	C	B	C	C
GENERAL UNIT DATA													
Number of Independent Refrigerant Circuits	2												
Refrigerant Charge, R-134a, Ckt.-1/Ckt.-2, lbs	175/175	190/190	225/225	175/155	190/170	220/195	205/205	175/175	225/225	240/240	210/190	250/225	250/250
Oil Charge, Ckt.-1/Ckt.-2, gal	2.1/2.0	2.2/2.2	2.5/2.5	2.4/2.0	2.6/2.1	2.7/2.2	2.6/2.6	2.5/2.5	2.8/2.8	2.9/2.9	2.7/2.6	2.9/2.8	2.9/2.9
% Minimum Load	10%												
Unit shipping weight, lbs ¹	11518	12084	14668	12019	12781	13776	13392	12859	14915	15677	13288	15873	16634
Operating Weight, lbs ¹	11979	12546	15432	12460	13222	14237	14155	13300	15678	16440	13750	16636	17398
Chassis Dimensions - Length, Ft	203.3	247.2	291.2	247.0	291.2	335.2	226.0	291.2	291.2	335.2	291.2	335.2	379.1
Chassis Dimensions - Width, Ft	88.3	88.3	88.3	88.3	88.3	88.3	88.3	88.3	88.3	88.3	88.3	88.3	88.3
Chassis Dimensions - Height, Ft	94.6	94.6	94.6	94.6	94.6	94.6	94.6	94.6	94.6	94.6	94.6	94.6	94.6
COMPRESSORS, SEMI-HERMETIC SCREW													
Qty per Chiller	2												
CONDENSER FANS													
Number Ckt-1/Ckt-2	4/4	5/5	6/6	6/4	7/5	8/6	4/4	6/6	6/6	7/7	7/5	8/6	8/8
Air on Condenser (Min/Max), °F	0/125												
EVAPORATOR, SHELL AND TUBE HYBRID FALLING FILM ²													
Water Volume, gal	58	58	71	48	48	58	71	48	71	71	58	71	71
Leaving Water Temperature (Min/Max), °F ³	40/60												
Maximum Water Side Pressure, psig	150												
Maximum Refrigerant Side Pressure, psig	235												
Evap Drain Connection, in	3/4												

NOTES:

- Shipping and operating weights shown are for base unit; selected options may add weight to unit. Contact your nearest Johnson Controls Sales office for weight data.
- The evaporator is protected against freezing to 0°F (-17.8°C) with a standard heater.
- For leaving liquid temperature below 40°F (4.4°C) or above 60°F (15.6°C), contact your nearest Johnson Controls Sales Office for application requirements.

The data shown in this table is applicable to selected typical configurations. Other configurations are available through our configuration/selection software. Please contact your nearest Johnson Controls Sales Office for the chiller configuration that best matches your specific needs.

UNIT FRAME	026	027	027	027	029	030	030	030	031	032	033	034	034
CONDENSER CODE	3	3	5	8	5	3	5	8	8	3	3	3	5
EVAPORATOR CODE	B	D	E	E	E	C	C	E	E	E	C	E	E
GENERAL UNIT DATA													
Number of Independent Refrigerant Circuits	2												
Refrigerant Charge, R-134a, Ckt.-1/Ckt.-2, lbs	210/210	265/265	265/265	270/270	310/265	290/245	295/250	315/275	315/295	295/295	290/290	310/310	315/315
Oil Charge, Ckt.-1/Ckt.-2, gal	2.7/2.7	3.0/3.0	3.0/3.0	3.1/3.1	4.2/3.1	4.1/3.0	4.1/3.0	4.3/3.2	4.3/3.3	4.1/4.1	4.1/4.1	4.2/4.2	4.3/4.3
% Minimum Load	10%												
Unit shipping weight, lbs ¹	14076	16275	16991	17753	18205	17114	18967	18967	19728	18554	18224	19315	20077
Operating Weight, lbs ¹	14538	17103	17851	18612	19065	17877	19827	19827	20588	19414	18987	20175	20937
Chassis Dimensions - Length, Ft	335.2	335.2	335.2	379.2	379.2	379.2	423.1	423.1	467.1	379.2	423.1	423.1	467.1
Chassis Dimensions - Width, Ft	88.3	88.3	88.3	88.3	88.3	88.3	88.3	88.3	88.3	88.3	88.3	88.3	88.3
Chassis Dimensions - Height, Ft	94.6	94.6	94.6	94.6	94.6	94.6	94.6	94.6	94.6	94.6	94.6	94.6	94.6
COMPRESSORS, SEMI-HERMETIC SCREW													
Qty per Chiller	2												
CONDENSER FANS													
Number Ckt-1/Ckt-2	7/7	7/7	7/7	8/8	9/7	9/7	10/8	10/8	10/10	8/8	9/9	9/9	10/10
Air on Condenser (Min/Max), °F	0/125												
EVAPORATOR, SHELL AND TUBE HYBRID FALLING FILM ²													
Water Volume, gal	58	82	113	113	113	71	71	113	113	113	71	113	113
Leaving Water Temperature (Min/Max), °F ³	40/60												
Maximum Water Side Pressure, psig	150												
Maximum Refrigerant Side Pressure, psig	235												
Evap Drain Connection, in	3/4												

NOTES:

- Shipping and operating weights shown are for base unit; selected options may add weight to unit. Contact your nearest Johnson Controls Sales office for weight data.
- The evaporator is protected against freezing to 0°F (-17.8°C) with a standard heater.
- For leaving liquid temperature below 40°F (4.4°C) or above 60°F (15.6°C), contact your nearest Johnson Controls Sales Office for application requirements.

Physical Data - SI

The data shown in this table is applicable to selected typical configurations. Other configurations are available through our configuration/selection software. Please contact your nearest Johnson Controls Sales Office for the chiller configuration that best matches your specific needs.

UNIT FRAME	015	016	017	018	019	019	020	021	021	021	023	024	024
CONDENSER CODE	3	5	8	3	5	8	0	3	5	8	3	5	8
EVAPORATOR CODE	B	B	C	A	A	B	C	A	C	C	B	C	C
GENERAL UNIT DATA													
Number of Independent Refrigerant Circuits	2												
Refrigerant Charge, R-134a, Ckt.-1/Ckt.-2, kg	80/80	86/86	102/102	80/70	86/78	100/89	93/93	80/80	102/102	109/109	96/86	114/102	114/114
Oil Charge, Ckt.-1/Ckt.-2, liters	8.0/7.7	8.5/8.5	9.3/9.3	9.2/7.7	9.7/8.0	10.4/8.5	10.0/10.0	9.3/9.3	10.5/10.5	10.8/10.8	10.1/9.7	11.1/10.5	11.1/11.1
% Minimum Load	10%												
Unit Shipping Weight, kg ¹	5224	5481	6653	5452	5797	6248	6074	5833	6765	7111	6027	7200	7545
Operating Weight, kg ¹	5434	5691	7000	5652	5997	6458	6421	6033	7111	7457	6237	7546	7891
Chassis Dimensions - Length, mm	5163	6280	7397	6274	7397	8514	5741	7397	7397	8514	7397	8514	9631
Chassis Dimensions - Width, mm	2242	2242	2242	2242	2242	2242	2242	2242	2242	2242	2242	2242	2242
Chassis Dimensions - Height, mm	2403	2403	2403	2403	2403	2403	2403	2403	2403	2403	2403	2403	2403
COMPRESSORS, SEMI-HERMETIC SCREW													
Qty per Chiller	2												
CONDENSER FANS													
Number Ckt-1/Ckt-2	4/4	5/5	6/6	6/4	7/5	8/6	4/4	6/6	6/6	7/7	7/5	8/6	8/8
Air on Condenser (Min/Max), °C	-17.8/51.7												
EVAPORATOR, SHELL AND TUBE HYBRID FALLING FILM ²													
Water Volume, liters	220	220	269	182	182	220	269	182	269	269	220	269	269
Leaving Water Temperature (Min/Max), °C ³	4.4/15.6												
Maximum Water Side Pressure, bar	10.3												
Maximum Refrigerant Side Pressure, bar	16.2												
Evap Drain Connection, in	3/4												

NOTES:

- Shipping and operating weights shown are for base unit; selected options may add weight to unit. Contact your nearest Johnson Controls Sales office for weight data.
- The evaporator is protected against freezing to 0°F(-17.8°C) with a standard heater.
- For leaving liquid temperature below 40°F(4.4°C) or above 60°F (15.6°C), contact your nearest Johnson Controls Sales Office for application requirements.

The data shown in this table is applicable to selected typical configurations. Other configurations are available through our configuration/selection software. Please contact your nearest Johnson Controls Sales Office for the chiller configuration that best matches your specific needs.

UNIT FRAME	026	027	027	027	029	030	030	030	031	032	033	034	034
CONDENSER CODE	3	3	5	8	5	3	5	8	8	3	3	3	5
EVAPORATOR CODE	B	D	E	E	E	C	C	E	E	E	C	E	E
GENERAL UNIT DATA													
Number of Independent Refrigerant Circuits	2												
Refrigerant Charge, R-134a, Ckt.-1/Ckt.-2, kg	96/96	120/120	121/121	123/123	141/120	132/111	134/114	143/125	143/134	134/134	132/132	141/141	143/143
Oil Charge, Ckt.-1/Ckt.-2, liters	10.1/10.1	11.4/11.4	11.4/11.4	11.6/11.6	15.9/11.7	15.5/11.4	15.5/11.4	16.3/12.1	16.3/12.5	15.5/15.5	15.5/15.5	15.9/15.9	16.3/16.3
% Minimum Load	10%												
Unit Shipping Weight, kg ¹	6385	7382	7707	8052	8258	7763	8603	8603	8948	8416	8266	8761	9107
Operating Weight, kg ¹	6594	7758	8097	8442	8648	8109	8993	8993	9339	8806	8612	9151	9497
Chassis Dimensions - Length, mm	8514	8514	8514	9631	9631	9631	10748	10748	11865	9631	10748	10748	11865
Chassis Dimensions - Width, mm	2242	2242	2242	2242	2242	2242	2242	2242	2242	2242	2242	2242	2242
Chassis Dimensions - Height, mm	2403	2403	2403	2403	2403	2403	2403	2403	2403	2403	2403	2403	2403
COMPRESSORS, SEMI-HERMETIC SCREW													
Qty per Chiller	2												
CONDENSER FANS													
Number Ckt-1/Ckt-2	7/7	7/7	7/7	8/8	9/7	9/7	10/8	10/8	10/10	8/8	9/9	9/9	10/10
Air on Condenser (Min/Max), °C	-17.8/51.7												
EVAPORATOR, SHELL AND TUBE HYBRID FALLING FILM ²													
Water Volume, liters	220	310	428	428	428	269	269	428	428	428	269	428	428
Leaving Water Temperature (Min/Max), °C ³	4.4/15.6												
Maximum Water Side Pressure, bar	10.3												
Maximum Refrigerant Side Pressure, bar	16.2												
Evap Drain Connection, in	3/4												

NOTES:

- Shipping and operating weights shown are for base unit; selected options may add weight to unit. Contact your nearest Johnson Controls Sales office for weight data.
- The evaporator is protected against freezing to 0°F (-17.8°C) with a standard heater.
- For leaving liquid temperature below 40°F (4.4°C) or above 60°F (15.6°C), contact your nearest Johnson Controls Sales Office for application requirements.

Evaporator Options

SIDE VIEW

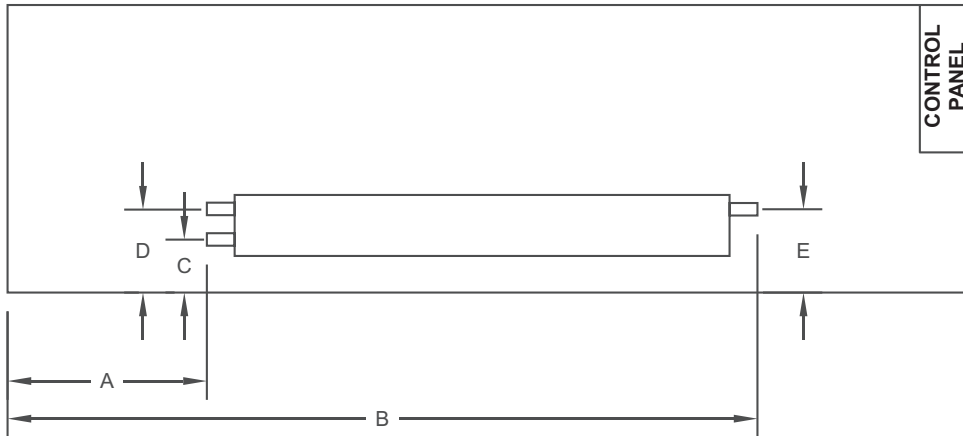

FRONT VIEW

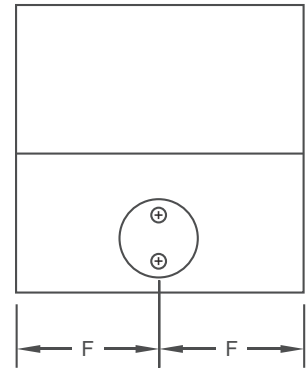

ENGLISH - ALL DIMENSIONS IN INCHES

YVAA MODEL			STANDARD (TWO-PASS, REAR INLET/OUTLET) EVAPORATOR								OPTIONAL THREE-PASS REAR INLET/FRONT OUTLET EVAPORATOR								
FRAME	COND.	EVAP.	A	C	D	F	C-606 CONN. SIZE	WATER VOL. GAL	MINIMUM CHILLED WATER FLOW RATE GPM	MAXIMUM CHILLED WATER FLOW RATE GPM	A	B	C	E	F	C-606 CONN. SIZE	WATER VOL. GAL	MINIMUM CHILLED WATER FLOW RATE GPM	MAXIMUM CHILLED WATER FLOW RATE GPM
015	3	B	6.9	15.1	26.5	44.1	6	58	250	950	6.9	168.9	15.1	26.5	44.1	5	58	160	600
016	5	B	29.4	15.1	26.5	44.1	6	58	250	950	29.4	191.4	15.1	26.5	44.1	5	58	160	600
017	8	C	34.9	15.1	26.5	44.1	6	71	300	1150	34.9	220.9	15.1	26.5	44.1	6	71	200	750
018	3	A	17.7	14.1	25.5	44.1	6	48	200	750	17.7	190.2	14.1	25.5	44.1	5	48	120	500
019	5	A	61.5	14.1	25.5	44.1	6	48	200	750	61.5	234.0	14.1	25.5	44.1	5	48	120	500
019	8	B	117.3	15.3	26.7	44.1	6	58	250	950	117.3	279.3	15.3	26.7	44.1	5	58	160	600
020	0	C	1.7	15.1	26.5	44.1	6	71	300	1150	1.7	187.7	15.1	26.5	44.1	6	71	200	750
021	3	A	61.7	14.1	25.5	44.1	6	48	200	750	61.7	234.2	14.1	25.5	44.1	5	48	120	500
021	5	C	34.9	15.1	26.5	44.1	6	71	300	1150	34.9	220.9	15.1	26.5	44.1	6	71	200	750
021	8	C	78.9	15.3	26.7	44.1	6	71	300	1150	78.9	264.9	15.3	26.7	44.1	6	71	200	750
023	3	B	73.3	15.1	26.5	44.1	6	58	250	950	73.3	235.3	15.1	26.5	44.1	5	58	160	600
024	5	C	92.9	15.3	26.7	44.1	6	71	300	1150	92.9	278.9	15.3	26.7	44.1	6	71	200	750
024	8	C	122.9	15.3	26.7	44.1	6	71	300	1150	122.9	308.9	15.3	26.7	44.1	6	71	200	750
026	3	B	117.3	15.3	26.7	44.1	6	58	250	950	117.3	279.3	15.3	26.7	44.1	5	58	160	600
027	3	D	42.9	15.3	26.7	44.1	6	82	300	1150	42.9	264.9	15.3	26.7	44.1	6	82	200	750
027	5	E	44.3	15.5	29.5	44.1	8	113	400	1500	44.3	263.3	15.5	29.5	44.1	6	113	300	850
027	8	E	88.3	15.5	29.5	44.1	8	113	400	1500	88.3	307.3	15.5	29.5	44.1	6	113	300	850
029	5	E	88.3	15.5	29.5	44.1	8	113	400	1500	88.3	307.3	15.5	29.5	44.1	6	113	300	850
030	3	C	122.9	15.3	26.7	44.1	6	71	300	1150	122.9	308.9	15.3	26.7	44.1	6	71	200	750
030	5	C	166.8	15.1	26.5	44.1	6	71	300	1150	166.8	352.8	15.1	26.5	44.1	6	71	200	750
030	8	E	132.2	15.5	29.5	44.1	8	113	400	1500	132.2	351.2	15.5	29.5	44.1	6	113	300	850
031	8	E	176.2	15.5	29.5	44.1	8	113	400	1500	176.2	395.2	15.5	29.5	44.1	6	113	300	850
032	3	E	88.3	15.5	29.5	44.1	8	113	400	1500	88.3	307.3	15.5	29.5	44.1	6	113	300	850
033	3	C	166.9	15.3	26.7	44.1	6	71	300	1150	166.9	352.9	15.3	26.7	44.1	6	71	200	750
034	3	E	132.2	15.5	29.5	44.1	8	113	400	1500	132.2	351.2	15.5	29.5	44.1	6	113	300	850
034	5	E	176.2	15.5	29.5	44.1	8	113	400	1500	176.2	395.2	15.5	29.5	44.1	6	113	300	850

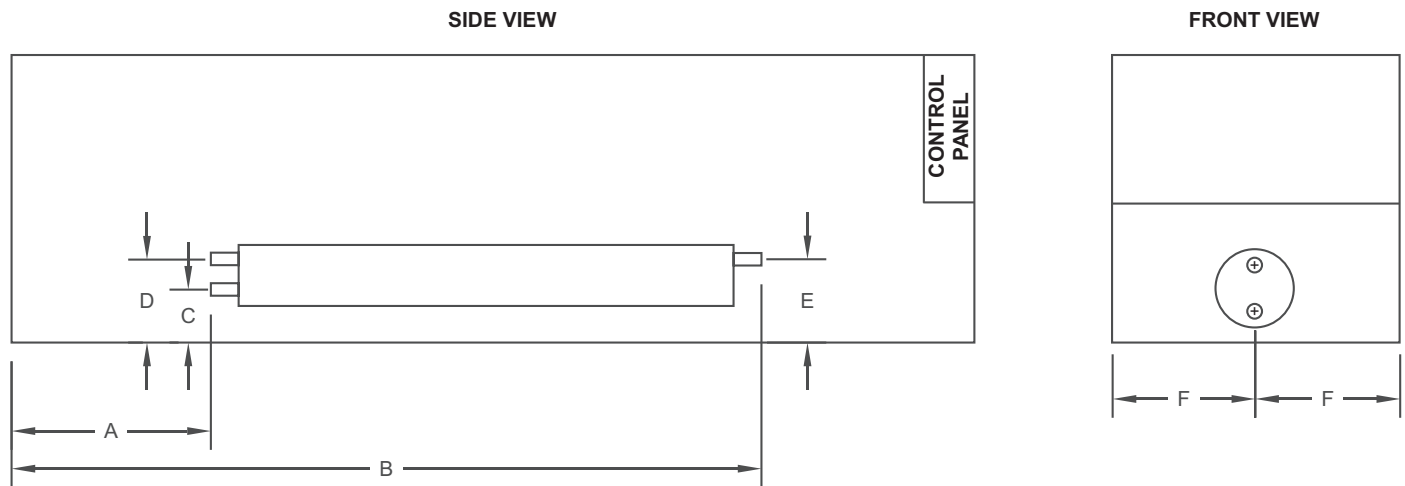

SI- ALL DIMENSIONS IN MM

YVAA MODEL			STANDARD (TWO-PASS, REAR INLET/OUTLET) EVAPORATOR								OPTIONAL THREE-PASS REAR INLET/FRONT OUTLET EVAPORATOR								
FRAME	COND.	EVAP.	A	C	D	G	C-606 CONN. SIZE	WATER VOL. LITERS	MINIMUM CHILLED WATER FLOW RATE l/s	MAXIMUM CHILLED WATER FLOW RATE l/s	A	B	E	F	G	C-606 CONN. SIZE	WATER VOL. LITERS	MINIMUM CHILLED WATER FLOW RATE l/s	MAXIMUM CHILLED WATER FLOW RATE l/s
015	3	B	176	384	674	1121	6	220	16	60	176	4291	384	674	1121	5	220	10	38
016	5	B	745	384	674	1121	6	220	16	60	745	4860	384	674	1121	5	220	10	38
017	8	C	887	384	674	1121	6	269	19	73	887	5611	384	674	1121	6	269	13	47
018	3	A	449	359	649	1121	6	182	13	47	449	4831	359	649	1121	5	182	8	32
019	5	A	1563	359	649	1121	6	182	13	47	1563	5945	359	649	1121	5	182	8	32
019	8	B	2979	388	678	1121	6	220	16	60	2979	7094	388	678	1121	5	220	10	38
020	0	C	43	384	674	1121	6	269	19	73	43	4767	384	674	1121	6	269	13	47
021	3	A	1566	359	649	1121	6	182	13	47	1566	5948	359	649	1121	5	182	8	32
021	5	C	887	384	674	1121	6	269	19	73	887	5611	384	674	1121	6	269	13	47
021	8	C	2004	388	678	1121	6	269	19	73	2004	6728	388	678	1121	6	269	13	47
023	3	B	1862	384	674	1121	6	220	16	60	1862	5977	384	674	1121	5	220	10	38
024	5	C	2359	388	678	1121	6	269	19	73	2359	7083	388	678	1121	6	269	13	47
024	8	C	3121	388	678	1121	6	269	19	73	3121	7845	388	678	1121	6	269	13	47
026	3	B	2979	388	678	1121	6	220	16	60	2979	7094	388	678	1121	5	220	10	38
027	3	D	1090	388	678	1121	6	310	19	73	1090	6729	388	678	1121	6	310	13	47
027	5	E	1125	394	749	1121	8	428	25	95	1125	6688	394	749	1121	6	428	19	54
027	8	E	2242	394	749	1121	8	428	25	95	2242	7805	394	749	1121	6	428	19	54
029	5	E	2242	394	749	1121	8	428	25	95	2242	7805	394	749	1121	6	428	19	54
030	3	C	3121	388	678	1121	6	269	19	73	3121	7845	388	678	1121	6	269	13	47
030	5	C	4235	384	674	1121	6	269	19	73	4235	8959	384	674	1121	6	269	13	47
030	8	E	3359	394	749	1121	8	428	25	95	3359	8922	394	749	1121	6	428	19	54
031	8	E	4476	394	749	1121	8	428	25	95	4476	10039	394	749	1121	6	428	19	54
032	3	E	2242	394	749	1121	8	428	25	95	2242	7805	394	749	1121	6	428	19	54
033	3	C	4238	388	678	1121	6	269	19	73	4238	8962	388	678	1121	6	269	13	47
034	3	E	3359	394	749	1121	8	428	25	95	3359	8922	394	749	1121	6	428	19	54
034	5	E	4476	394	749	1121	8	428	25	95	4476	10039	394	749	1121	6	428	19	54

Dimensions

The data shown in this table is applicable to selected typical configurations. Other configurations are available through our configuration/selection software. Please contact your nearest Johnson Controls Sales Office for the chiller configuration that best matches your specific needs.

ENGLISH AND SI DIMENSIONS

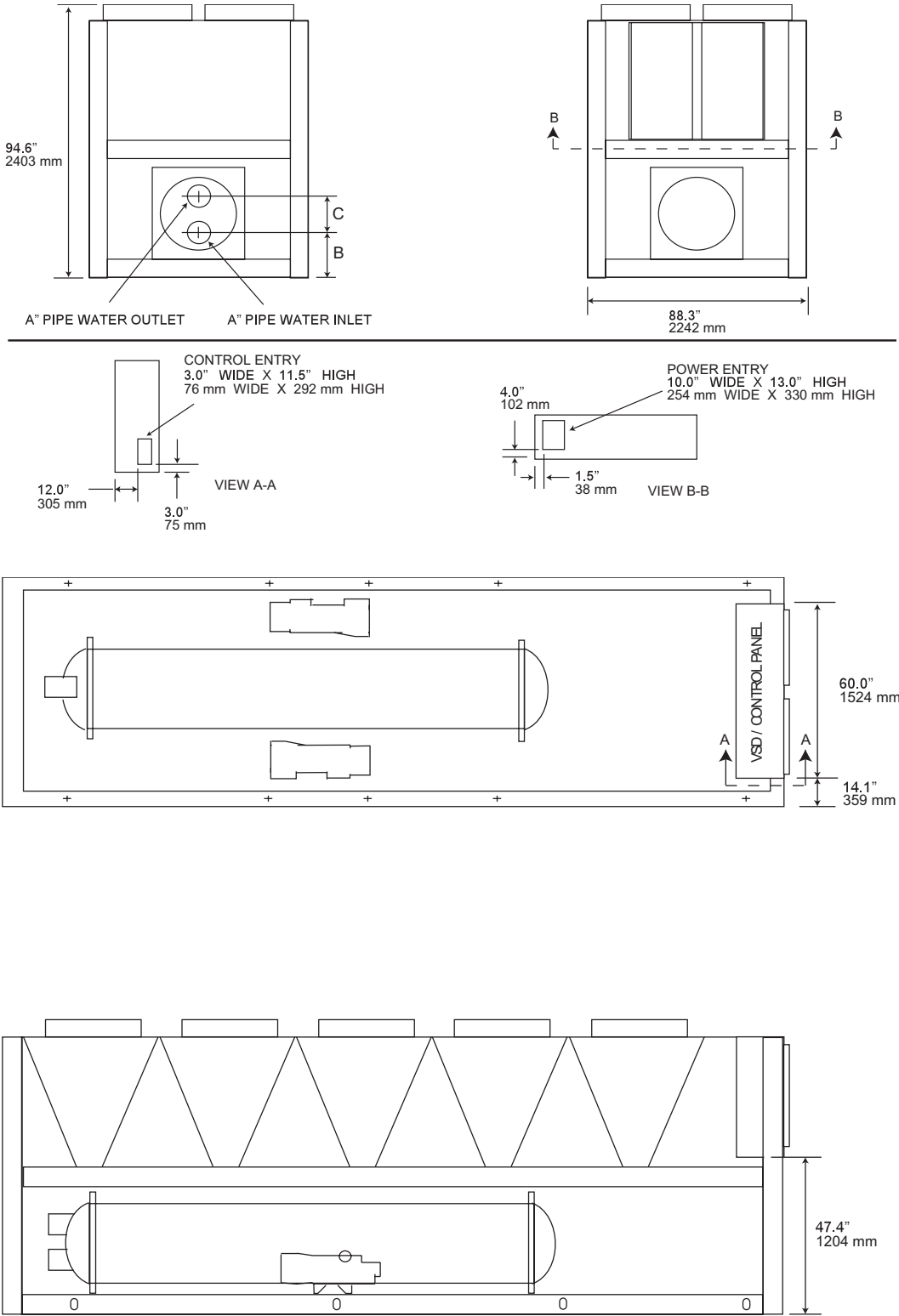

INTENTIONALLY LEFT BLANK

Rigging Hole Locations

ENGLISH

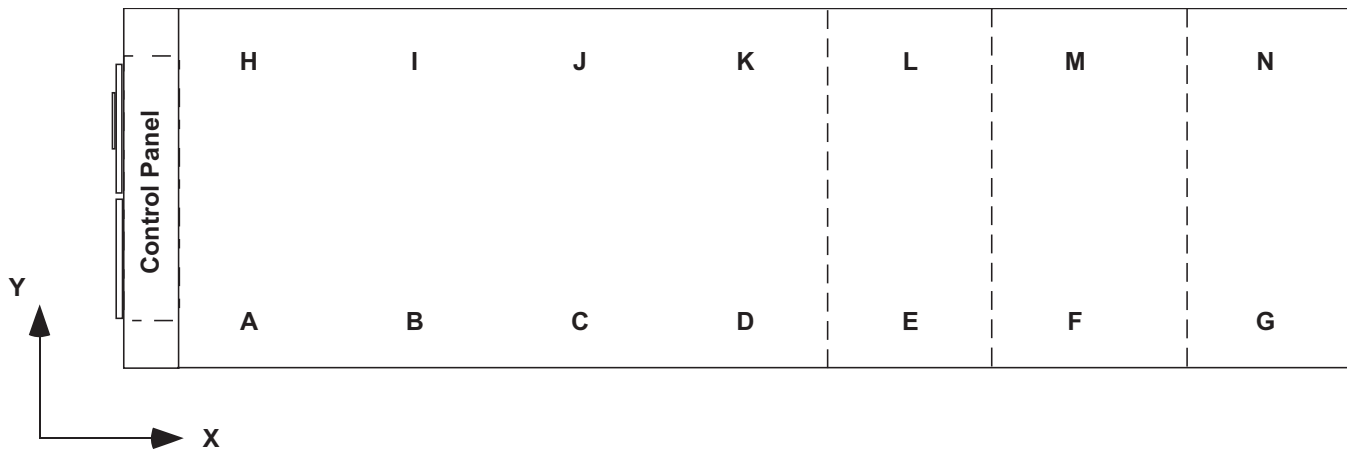

YVAA MODEL			DESCRIPTION	A	B	C	D	E	F	G	H	I	J	K	L	M	N	CENTER OF GRAVITY		
FRAME	COND	EVAP																X (IN)	Y (IN)	
015	3	B	Rigging Hole Location (in)	18	60	116	192				18	60	116	192					106	46
			Point Load (lbs)	1036	1675	1675	1372				952	1655	1655	1496						
016	5	B	Rigging Hole Location (in)	18	60	137	214				18	60	137	214					132	46
			Point Load (lbs)	626	1141	3081	1194				608	1121	3058	1255						
017	8	C	Rigging Hole Location (in)	12	73	144	197	260			12	73	144	197	260				151	46
			Point Load (lbs)	625	1746	2573	1287	1103			634	1612	2611	1305	1172					
018	3	A	Rigging Hole Location (in)	18	60	143	220				18	60	143	220					132	46
			Point Load (lbs)	502	1454	2886	1143				508	1422	2912	1193						
019	5	A	Rigging Hole Location (in)	18	60	143	227	272			18	60	143	227	272				144	46
			Point Load (lbs)	469	1471	2779	1390	256			484	1419	2833	1416	264					
019	8	B	Rigging Hole Location (in)	18	60	137	215	302			18	60	137	215	302				154	46
			Point Load (lbs)	418	1630	2443	1657	715			398	1633	2451	1716	715					
020	0	C	Rigging Hole Location (in)	18	60	131	214				18	60	131	214					114	46
			Point Load (lbs)	1199	750	3466	1280				1107	776	3428	1384						
021	3	A	Rigging Hole Location (in)	18	60	143	227	272			18	60	143	227	272				144	45
			Point Load (lbs)	472	1467	2824	1412	257			485	1416	2842	1421	265					
021	5	C	Rigging Hole Location (in)	12	73	144	197	260			12	73	144	197	260				158	46
			Point Load (lbs)	483	1990	1990	1673	1322			475	1937	1937	1721	1387					
021	8	C	Rigging Hole Location (in)	12	73	163	254	324			12	73	163	254	324				161	46
			Point Load (lbs)	518	2344	3047	1501	428			510	2282	2967	1743	336					
023	3	B	Rigging Hole Location (in)	18	60	137	215	272			18	60	137	215	272				140	46
			Point Load (lbs)	342	2052	2048	2048	144			330	2037	2067	2067	152					
024	5	C	Rigging Hole Location (in)	18	60	149	240	324			18	60	149	240	324				159	46
			Point Load (lbs)	358	2130	2982	2151	307			354	2079	2911	2340	261					

NOTE: Weights shown for base unit; selected options may add weight to unit. Contact your nearest Johnson Controls Sales Office for weight data.

SI

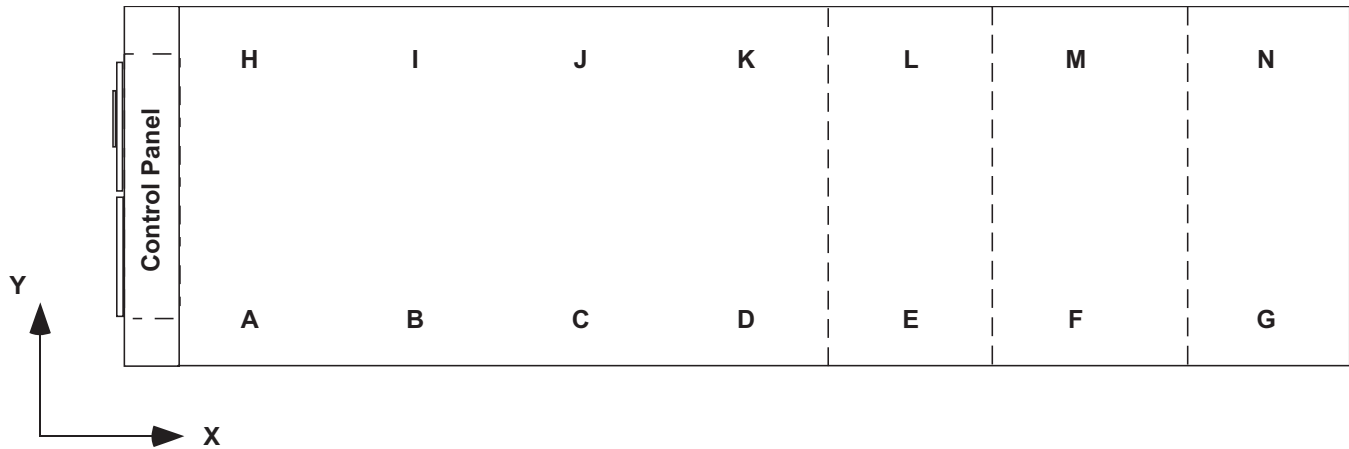

YVAA MODEL			DESCRIPTION	A	B	C	D	E	F	G	H	I	J	K	L	M	N	CENTER OF GRAVITY		
FRAME	COND	EVAP																X (MM)	Y (MM)	
015	3	B	Rigging Hole Location (mm)	464	1512	2937	4866				464	1512	2937	4866					2682	1164
			Point Load (kgs)	470	760	760	622				432	751	751	679						
016	5	B	Rigging Hole Location (mm)	464	1533	3485	5436				464	1533	3485	5436					3348	1158
			Point Load (kgs)	284	518	1398	542				276	508	1387	569						
017	8	C	Rigging Hole Location (mm)	314	1845	3654	5012	6593			314	1845	3654	5012	6593				3835	1173
			Point Load (kgs)	283	792	1167	584	500			288	731	1184	592	532					
018	3	A	Rigging Hole Location (mm)	464	1533	3637	5599				464	1533	3637	5599					3365	1161
			Point Load (kgs)	228	660	1309	518				230	645	1321	541						
019	5	A	Rigging Hole Location (mm)	464	1533	3636	5761	6920			464	1533	3636	5761	6920				3649	1162
			Point Load (kgs)	213	667	1261	630	116			220	644	1285	642	120					
019	8	B	Rigging Hole Location (mm)	464	1533	3485	5456	7670			464	1533	3485	5456	7670				3912	1161
			Point Load (kgs)	190	739	1108	752	324			181	741	1112	778	324					
020	0	C	Rigging Hole Location (mm)	464	1518	3332	5430				464	1518	3332	5430					2907	1168
			Point Load (kgs)	544	340	1572	581				502	352	1555	628						
021	3	A	Rigging Hole Location (mm)	464	1533	3636	5761	6920			464	1533	3636	5761	6920				3655	1155
			Point Load (kgs)	214	665	1281	640	117			220	642	1289	645	120					
021	5	C	Rigging Hole Location (mm)	314	1845	3654	5012	6593			314	1845	3654	5012	6593				4013	1176
			Point Load (kgs)	219	903	903	759	600			215	879	879	781	629					
021	8	C	Rigging Hole Location (mm)	314	1845	4144	6443	8217			314	1845	4144	6443	8217				4086	1173
			Point Load (kgs)	235	1063	1382	681	194			231	1035	1346	791	152					
023	3	B	Rigging Hole Location (mm)	464	1533	3484	5455	6919			464	1533	3484	5455	6919				3553	1160
			Point Load (kgs)	155	931	929	929	65			150	924	938	938	69					
024	5	C	Rigging Hole Location (mm)	464	1533	3789	6088	8217			464	1533	3789	6088	8217				4033	1174
			Point Load (kgs)	162	966	1353	976	139			161	943	1320	1061	118					

NOTE: Weights shown for base unit; selected options may add weight to unit. Contact your nearest Johnson Controls Sales Office for weight data.

Rigging Hole Locations - continued

ENGLISH

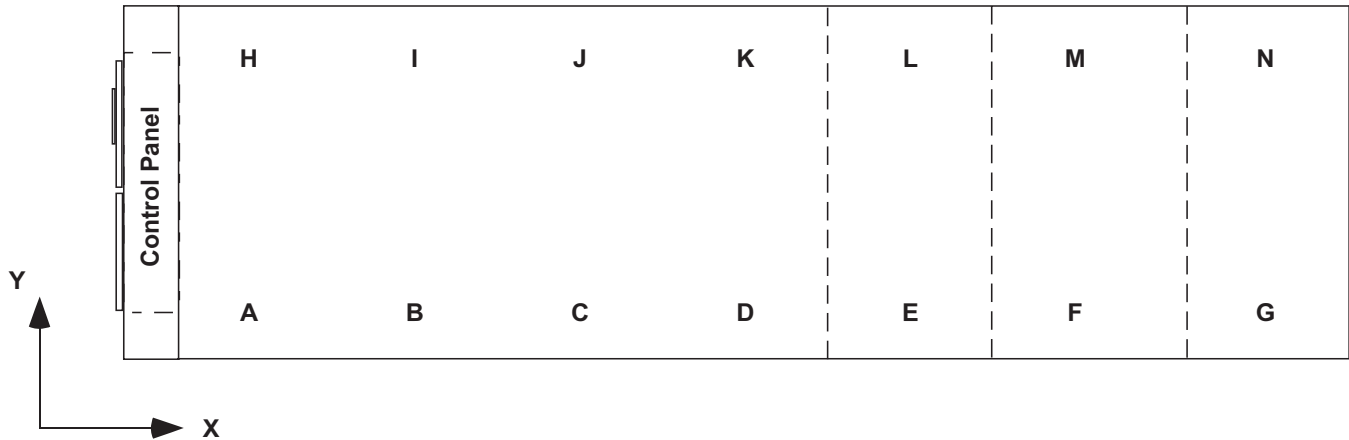

YVAA MODEL			DESCRIPTION	A	B	C	D	E	F	G	H	I	J	K	L	M	N	CENTER OF GRAVITY		
FRAME	COND	EVAP																X (IN)	Y (IN)	
024	8	C	Rigging Hole Location (in)	12	73	163	254	347			12	73	163	254	347				177	46
			Point Load (lbs)	697	1921	3078	1741	871			697	1800	3169	1773	886					
026	3	B	Rigging Hole Location (in)	18	60	137	215	302			18	60	137	215	302				152	45
			Point Load (lbs)	515	1613	2513	1682	714			493	1623	2486	1723	714					
027	3	D	Rigging Hole Location (in)	12	73	121	181	243	324		12	73	121	181	243	324			177	46
			Point Load (lbs)	736	1021	1226	3065	1393	696		653	1083	1174	2936	1527	763				
027	5	E	Rigging Hole Location (in)	12	73	121	181	264	324		12	73	121	181	264	324			177	46
			Point Load (lbs)	872	569	1525	3812	1146	573		803	586	1494	3734	1252	626				
027	8	E	Rigging Hole Location (in)	12	73	121	181	243	347		12	73	121	181	243	347			187	46
			Point Load (lbs)	616	1372	1138	2845	1937	968		542	1407	1099	2747	2054	1027				
029	5	E	Rigging Hole Location (in)	12	73	179	290	347			12	73	179	290	347				186	47
			Point Load (lbs)	500	1930	4518	1506	533			434	1937	4698	1566	583					
030	3	C	Rigging Hole Location (in)	12	73	161	254	348			12	73	163	254	347				175	47
			Point Load (lbs)	748	1875	3196	1748	874			748	1784	3464	1785	892					
030	5	C	Rigging Hole Location (in)	12	73	161	254	306	391		12	73	161	254	306	391			186	47
			Point Load (lbs)	559	2024	3021	2164	302	752		411	2226	2990	2374	299	752				
030	8	E	Rigging Hole Location (in)	12	73	121	179	243	296	391	12	73	121	179	243	296	391		196	47
			Point Load (lbs)	1113	323	2182	2182	1309	1505	753	1073	398	2162	2162	1547	1505	753			
031	8	E	Rigging Hole Location (in)	12	73	121	179	243	353	435	12	73	121	179	243	353	435	207	46	
			Point Load (lbs)	1028	575	2009	2009	2022	1580	527	988	650	1988	1988	2259	1580	527			
032	3	E	Rigging Hole Location (in)	12	73	121	181	243	347		12	73	121	181	243	347			186	46
			Point Load (lbs)	701	1261	1250	3125	1960	980		604	1370	1204	3010	2060	1030				
033	3	C	Rigging Hole Location (in)	12	73	163	254	306	391		12	73	163	254	306	391			186	46
			Point Load (lbs)	550	2052	3327	2098	333	752		373	2354	2951	2387	295	752				
034	3	E	Rigging Hole Location (in)	12	73	121	181	243	296	392	12	73	121	181	243	296	392	196	46	
			Point Load (lbs)	1087	408	2224	2224	1456	1505	753	1038	514	2135	2135	1578	1505	753			
034	5	E	Rigging Hole Location (in)	12	73	121	181	243	353	435	12	73	121	181	243	353	435	207	46	
			Point Load (lbs)	1002	659	2048	2048	2173	1580	527	953	765	1959	1959	2295	1580	527			

NOTE: Weights shown for base unit; selected options may add weight to unit. Contact your nearest Johnson Controls Sales Office for weight data.

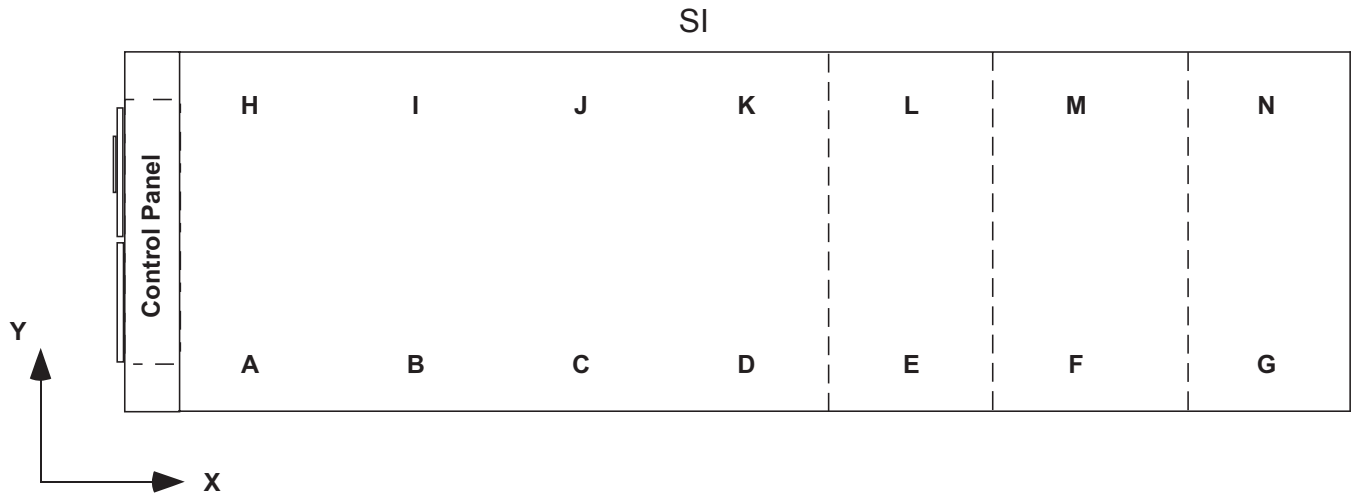

YVAA MODEL			DESCRIPTION	A	B	C	D	E	F	G	H	I	J	K	L	M	N	CENTER OF GRAVITY			
FRAME	COND	EVAP																X (MM)	Y (MM)		
024	8	C	Rigging Hole Location (mm)	314	1845	4144	6525	6525			314	1845	4144	6525	6525				4500	1172	
			Point Load (kgs)	316	871	1396	790	395				316	816	1437	804	402					
026	3	B	Rigging Hole Location (mm)	464	1533	3484	5455	7669			464	1533	3484	5455	7669				3866	1153	
			Point Load (kgs)	234	732	1140	763	324				224	736	1128	782	324					
027	3	D	Rigging Hole Location (mm)	314	1845	3073	4602	6170	8219			314	1845	3073	4602	6170	8219		4506	1176	
			Point Load (kgs)	334	463	556	1390	632	316			296	491	533	1332	693	346				
027	5	E	Rigging Hole Location (mm)	314	1845	3073	4602	6717	8218			314	1845	3073	4602	6717	8218		4506	1176	
			Point Load (kgs)	396	258	692	1729	520	260			364	266	678	1694	568	284				
027	8	E	Rigging Hole Location (mm)	314	1845	3073	4602	6170	8826			314	1845	3073	4602	6170	8826		4747	1173	
			Point Load (kgs)	279	622	516	1290	879	439			246	638	498	1246	932	466				
029	5	E	Rigging Hole Location (mm)	314	1845	4551	7358	8825			314	1845	4551	7358	8825				4712	1186	
			Point Load (kgs)	227	875	2049	683	242				197	879	2131	710	264					
030	3	C	Rigging Hole Location (mm)	314	1845	4092	6443	8824			314	1845	4092	6443	8824				4441	1184	
			Point Load (kgs)	339	850	1450	793	396				339	809	1571	810	405					
030	5	C	Rigging Hole Location (mm)	314	1845	4092	6443	7763	9941			314	1845	4092	6443	7763	9941		4729	1183	
			Point Load (kgs)	254	918	1370	982	137	341			186	1010	1356	1077	136	341				
030	8	E	Rigging Hole Location (mm)	314	1845	3073	4550	6170	7510	9943			314	1845	3073	4550	6170	7510	9943	4971	1183
			Point Load (kgs)	505	147	990	990	594	683	342	487	181	981	981	702	683	342				
031	8	E	Rigging Hole Location (mm)	314	1845	3073	4550	6169	8962	11059			314	1845	3073	4550	6169	8962	11059	5256	1181
			Point Load (kgs)	466	261	911	911	917	717	239	448	295	902	902	1025	717	239				
032	3	E	Rigging Hole Location (mm)	314	1845	3073	4602	6170	8826			314	1845	3072	4601	6169	8825		4717	1171	
			Point Load (kgs)	318	572	567	1417	889	445			274	621	546	1365	934	467				
033	3	C	Rigging Hole Location (mm)	314	1845	4144	6443	7765	9942			314	1845	4144	6443	7765	9942		4737	1166	
			Point Load (kgs)	249	931	1509	952	151	341			169	1068	1339	1083	134	341				
034	3	E	Rigging Hole Location (mm)	314	1845	3073	4602	6170	7510	9943			314	1845	3073	4602	6170	7510	9943	4974	1169
			Point Load (kgs)	493	185	1009	1009	660	683	342	471	233	968	968	716	683	342				
034	5	E	Rigging Hole Location (mm)	314	1845	3073	4602	6170	8963	11060			314	1845	3073	4602	6170	8963	11060	5254	1167
			Point Load (kgs)	454	299	929	929	986	717	239	432	347	889	889	1041	717	239				

NOTE: Weights shown for base unit; selected options may add weight to unit. Contact your nearest Johnson Controls Sales Office for weight data.

Isolator Locations

ENGLISH

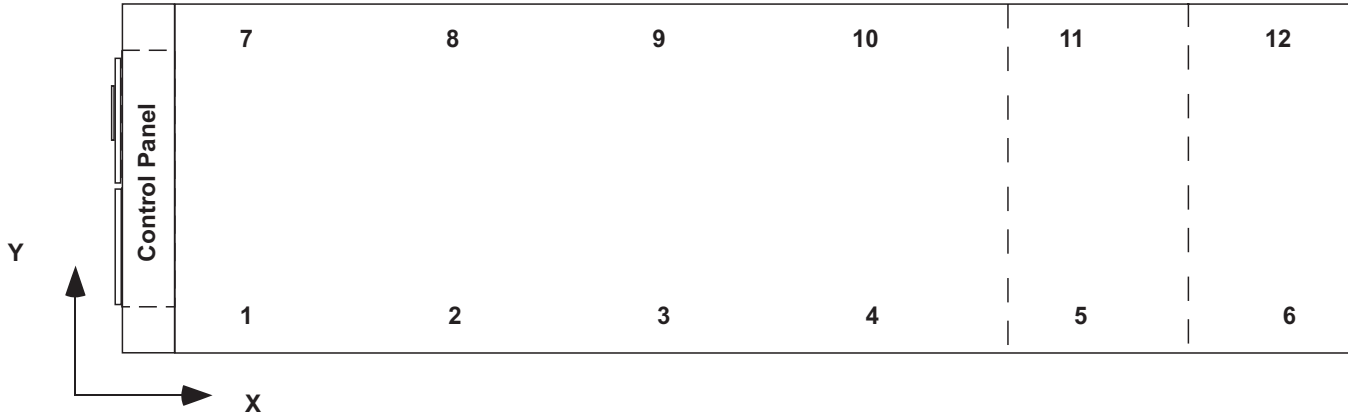

YVAA MODEL			DESCRIPTION	1	2	3	4	5	6	7	8	9	10	11	12
FRAME	COND	EVAP													
015	3	B	Isolator X-Dimension (in)	10	73	144	193			10	73	144	193		
			Isolator Y-Dimension (in)	1						87					
			Point Load (lbs)	1055	2150	2150	635			981	2119	2119	771		
016	5	B	Isolator X-Dimension (in)	10	77	118	157	220		10	77	118	157	220	
			Isolator Y-Dimension (in)	1						87					
			Point Load (lbs)	883	764	1788	1788	1048		865	736	1786	1786	1100	
017	8	C	Isolator X-Dimension (in)	10	81	149	187	251		10	81	149	187	251	
			Isolator Y-Dimension (in)	1						87					
			Point Load (lbs)	734	2308	1598	1598	1477		726	2201	1616	1616	1557	
018	3	A	Isolator X-Dimension (in)	10	76	124	163	210		10	76	124	163	210	
			Isolator Y-Dimension (in)	1						87					
			Point Load (lbs)	714	1658	1089	1089	1655		708	1652	1085	1085	1725	
019	5	A	Isolator X-Dimension (in)	10	76	118	157	208	281	10	76	118	157	208	281
			Isolator Y-Dimension (in)	1						87					
			Point Load (lbs)	851	851	1315	2167	701	701	845	845	1289	2224	717	717
019	8	B	Isolator X-Dimension (in)	10	76	118	157	209	308	10	76	118	157	209	308
			Isolator Y-Dimension (in)	1						87					
			Point Load (lbs)	620	2105	664	664	2438	603	600	2121	655	655	2511	603
020	0	C	Isolator X-Dimension (in)	10	46	107	154	217		10	46	107	154	217	
			Isolator Y-Dimension (in)	1						87					
			Point Load (lbs)	903	970	1964	1939	1302		833	964	1955	1928	1398	
021	3	A	Isolator X-Dimension (in)	10	76	118	157	209	281	10	76	118	157	209	281
			Isolator Y-Dimension (in)	1						87					
			Point Load (lbs)	853	853	1324	2202	709	709	847	847	1293	2228	717	717
021	5	C	Isolator X-Dimension (in)	10	81	149	187	251		10	81	149	187	251	
			Isolator Y-Dimension (in)	1						87					
			Point Load (lbs)	661	2075	1706	1706	1692		655	1990	1711	1711	1771	
021	8	C	Isolator X-Dimension (in)	10	81	149	187	235	301	10	81	149	187	235	301
			Isolator Y-Dimension (in)	1						87					
			Point Load (lbs)	717	2727	564	564	2431	1216	704	2650	571	571	2482	1241
023	3	B	Isolator X-Dimension (in)	10	76	118	157	209	281	10	76	118	157	209	281
			Isolator Y-Dimension (in)	1						87					
			Point Load (lbs)	950	950	1426	2226	658	658	936	936	1433	2243	669	669
024	5	C	Isolator X-Dimension (in)	10	76	128	173	220	301	10	76	128	173	220	301
			Isolator Y-Dimension (in)	1						87					
			Point Load (lbs)	813	1915	1459	1459	1775	887	807	1825	1482	1482	1821	910

NOTE: Weights shown for base unit; selected options may add weight to unit. Contact your nearest Johnson Controls Sales Office for weight data.

SI

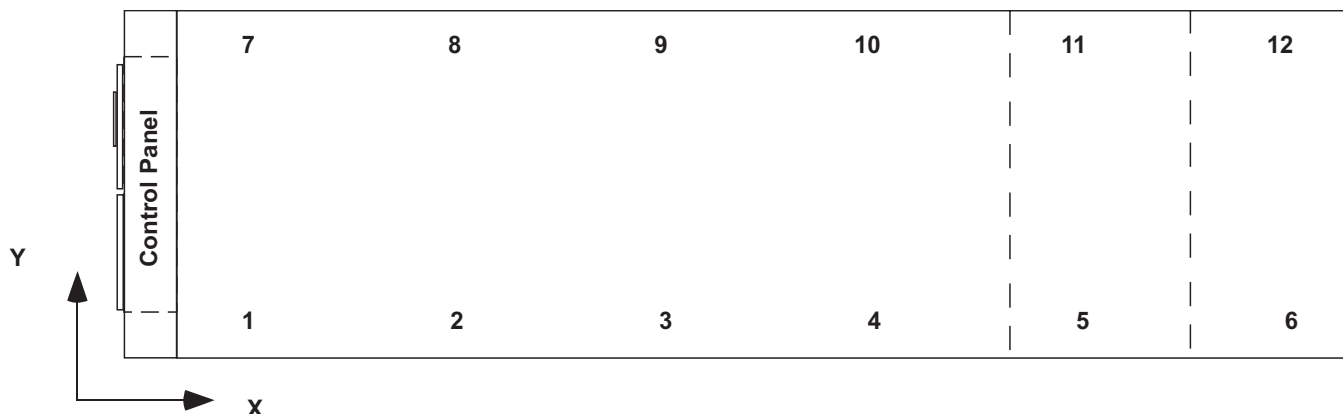

YVAA MODEL			DESCRIPTION	1	2	3	4	5	6	7	8	9	10	11	12		
FRAME	COND	EVAP															
015	3	B	Isolator X-Dimension (mm)	263	1852	3662	4900			263	1852	3662	4900				
			Isolator Y-Dimension (mm)	34						2206							
			Point Load (kgs)	479	975	975	288			445	961	961	350				
016	5	B	Isolator X-Dimension (mm)	263	1943	3000	3985	5589			263	1943	3000	3985	5589		
			Isolator Y-Dimension (mm)	34						2206							
			Point Load (kgs)	401	347	811	811	475			392	334	810	810	499		
017	8	C	Isolator X-Dimension (mm)	263	2057	3779	4756	6368			263	2057	3779	4756	6368		
			Isolator Y-Dimension (mm)	34						2206							
			Point Load (kgs)	333	1047	725	725	670			329	998	733	733	706		
018	3	A	Isolator X-Dimension (mm)	263	1943	3152	4137	5323			263	1943	3152	4137	5323		
			Isolator Y-Dimension (mm)	34						2206							
			Point Load (kgs)	324	752	494	494	751			321	749	492	492	782		
019	5	A	Isolator X-Dimension (mm)	259	1939	2997	3982	5295	7132			259	1939	2997	3982	5295	7132
			Isolator Y-Dimension (mm)	34						2206							
			Point Load (kgs)	386	386	596	983	318	318			383	383	585	1009	325	325
019	8	B	Isolator X-Dimension (mm)	263	1943	3000	3985	5299	7823			263	1943	3000	3985	5299	7823
			Isolator Y-Dimension (mm)	34						2206							
			Point Load (kgs)	281	955	301	301	1106	274			272	962	297	297	1139	274
020	0	C	Isolator X-Dimension (mm)	263	1159	2707	3922	5501			263	1159	2707	3922	5501		
			Isolator Y-Dimension (mm)	34						2206							
			Point Load (kgs)	410	440	891	880	591			378	437	887	875	634		
021	3	A	Isolator X-Dimension (mm)	263	1943	3000	3985	5299	7136			263	1943	3000	3985	5299	7136
			Isolator Y-Dimension (mm)	34						2206							
			Point Load (kgs)	387	387	601	999	322	322			384	384	586	1011	325	325
021	5	C	Isolator X-Dimension (mm)	263	2057	3779	4756	6368			263	2057	3779	4756	6368		
			Isolator Y-Dimension (mm)	34						2206							
			Point Load (kgs)	300	941	774	774	767			297	903	776	776	803		
021	8	C	Isolator X-Dimension (mm)	263	2057	3779	4756	5968	7653			263	2057	3779	4756	5968	7653
			Isolator Y-Dimension (mm)	34						2206							
			Point Load (kgs)	325	1237	256	256	1103	552			319	1202	259	259	1126	563
023	3	B	Isolator X-Dimension (mm)	263	1943	2999	3984	5298	7135			263	1943	2999	3984	5298	7135
			Isolator Y-Dimension (mm)	34						2206							
			Point Load (kgs)	431	431	647	1010	298	298			425	425	650	1017	303	303
024	5	C	Isolator X-Dimension (mm)	263	1943	3260	4391	5579	7654			263	1943	3260	4391	5579	7654
			Isolator Y-Dimension (mm)	34						2206							
			Point Load (kgs)	369	869	662	662	805	402			366	828	672	672	826	413

NOTE: Weights shown for base unit; selected options may add weight to unit. Contact your nearest Johnson Controls Sales Office for weight data.

Isolator Locations - continued

ENGLISH

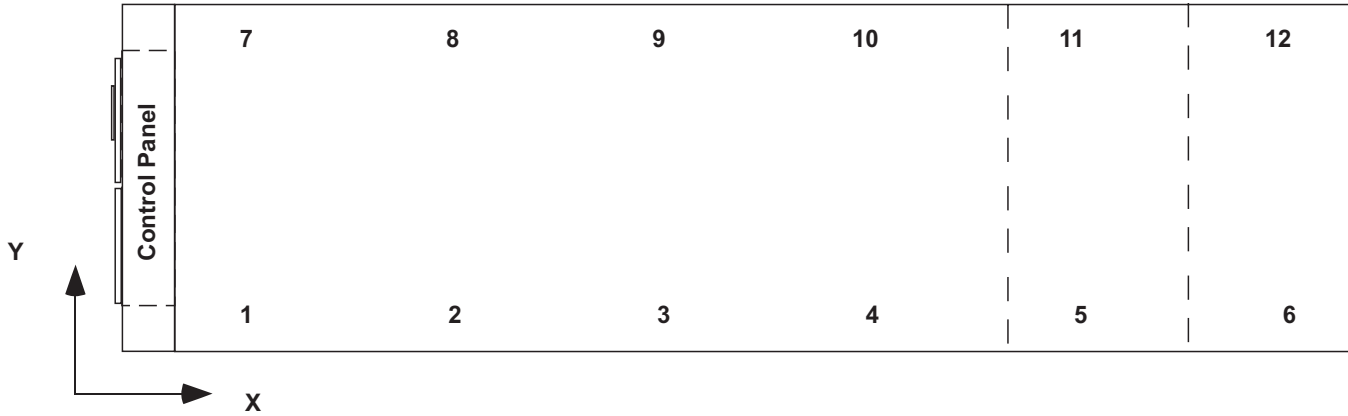

YVAA MODEL			DESCRIPTION	1	2	3	4	5	6	7	8	9	10	11	12
FRAME	COND	EVAP													
024	8	C	Isolator X-Dimension (in)	10	81	143	187	245	339	10	81	143	187	245	339
			Isolator Y-Dimension (in)	1						87					
			Point Load (lbs)	663	1795	2030	2030	1086	1086	663	1646	2097	2097	1102	1102
026	3	B	Isolator X-Dimension (in)	10	76	118	157	209	308	10	76	118	157	209	308
			Isolator Y-Dimension (in)	1						87					
			Point Load (lbs)	699	2111	694	694	2468	604	680	2126	671	671	2518	604
027	3	D	Isolator X-Dimension (in)	10	81	161	201	301		10	81	161	201	301	
			Isolator Y-Dimension (in)	1						87					
			Point Load (lbs)	712	1544	2775	2134	1387		682	1377	3032	1944	1516	
027	5	E	Isolator X-Dimension (in)	10	81	161	201	301		10	81	161	201	301	
			Isolator Y-Dimension (in)	1						87					
			Point Load (lbs)	691	1646	2871	2282	1435		662	1480	3128	2092	1564	
027	8	E	Isolator X-Dimension (in)	10	81	161	201	298	339	10	81	161	201	298	339
			Isolator Y-Dimension (in)	1						87					
			Point Load (lbs)	652	1773	2533	2533	907	907	598	1733	2527	2527	961	961
029	5	E	Isolator X-Dimension (in)	10	81	161	201	296	339	10	81	161	201	296	339
			Isolator Y-Dimension (in)	1						87					
			Point Load (lbs)	693	1821	2532	2532	919	919	629	1830	2621	2621	973	973
030	3	C	Isolator X-Dimension (in)	10	81	143	187	245	339	10	81	143	187	245	339
			Isolator Y-Dimension (in)	1						87					
			Point Load (lbs)	711	1804	2071	2071	1083	1083	711	1668	2245	2245	1092	1092
030	5	C	Isolator X-Dimension (in)	10	81	144	187	277	383	10	81	144	187	277	383
			Isolator Y-Dimension (in)	1						87					
			Point Load (lbs)	870	1451	2185	2185	1652	861	765	1551	2240	2240	1779	861
030	8	E	Isolator X-Dimension (in)	10	81	161	201	298	383	10	81	161	201	298	383
			Isolator Y-Dimension (in)	1						87					
			Point Load (lbs)	800	2001	2138	2138	1857	863	789	1968	2235	2235	1938	863
031	8	E	Isolator X-Dimension (in)	10	81	161	201	298	427	10	81	161	201	298	427
			Isolator Y-Dimension (in)	1						87					
			Point Load (lbs)	788	2032	2067	2067	2211	1013	778	1999	2164	2164	2292	1013
032	3	E	Isolator X-Dimension (in)	10	81	161	201	298	339	10	81	161	201	298	339
			Isolator Y-Dimension (in)	1						87					
			Point Load (lbs)	702	1771	2699	2699	918	918	635	1794	2675	2675	963	963
033	3	C	Isolator X-Dimension (in)	10	81	143	188	245	383	10	81	143	188	245	383
			Isolator Y-Dimension (in)	1						87					
			Point Load (lbs)	575	2930	891	891	3346	861	441	3177	707	707	3601	861
034	3	E	Isolator X-Dimension (in)	10	81	161	201	298	383	10	81	161	201	298	383
			Isolator Y-Dimension (in)	1						87					
			Point Load (lbs)	801	1996	2260	2260	1909	863	789	1967	2259	2259	1951	863
034	5	E	Isolator X-Dimension (in)	10	81	161	201	298	427	10	81	161	201	298	427
			Isolator Y-Dimension (in)	1						87					
			Point Load (lbs)	789	2027	2188	2188	2263	1013	778	1998	2187	2187	2305	1013

NOTE: Weights shown for base unit; selected options may add weight to unit. Contact your nearest Johnson Controls Sales Office for weight data.

SI

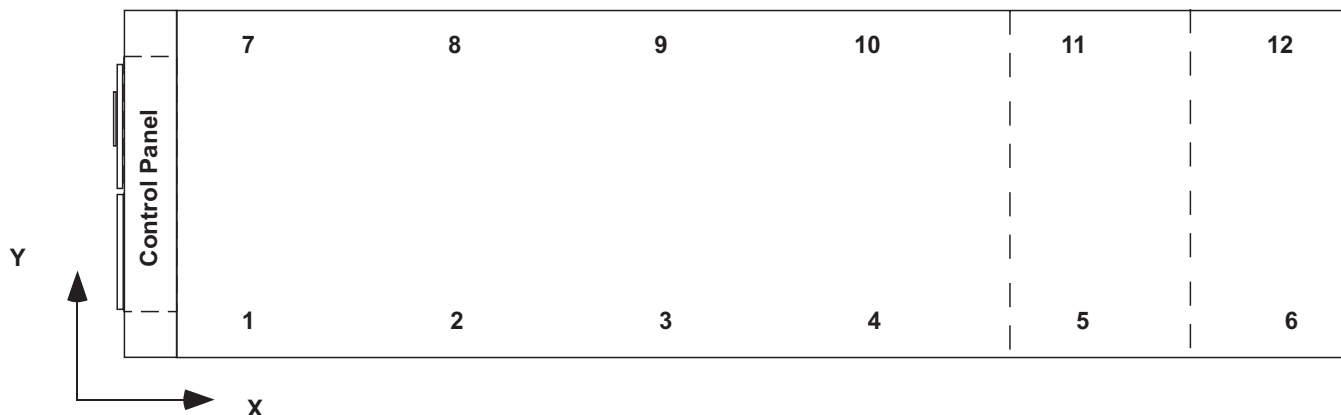

YVAA MODEL			DESCRIPTION	1	2	3	4	5	6	7	8	9	10	11	12
FRAME	COND	EVAP													
024	8	C	Isolator X-Dimension (mm)	263	2057	3638	4748	6232	8609	263	2057	3638	4748	6232	8609
			Isolator Y-Dimension (mm)	34						2206					
			Point Load (kgs)	301	814	921	921	493	493	301	747	951	951	500	500
026	3	B	Isolator X-Dimension (mm)	263	1943	2999	3984	5298	7823	263	1943	2999	3984	5298	7823
			Isolator Y-Dimension (mm)	34						2206					
			Point Load (kgs)	317	958	315	315	1119	274	308	964	304	304	1142	274
027	3	D	Isolator X-Dimension (mm)	263	2057	4084	5105	7654		263	2057	4084	5105	7654	
			Isolator Y-Dimension (mm)	34						2206					
			Point Load (kgs)	323	700	1259	968	629		309	625	1375	882	688	
027	5	E	Isolator X-Dimension (mm)	263	2057	4084	5105	7654		263	2057	4084	5105	7654	
			Isolator Y-Dimension (mm)	34						2206					
			Point Load (kgs)	313	747	1302	1035	651		300	671	1419	949	709	
027	8	E	Isolator X-Dimension (mm)	263	2057	4084	5105	7582	8609	263	2057	4084	5105	7582	8609
			Isolator Y-Dimension (mm)	34						2206					
			Point Load (kgs)	296	804	1149	1149	411	411	271	786	1146	1146	436	436
029	5	E	Isolator X-Dimension (mm)	263	2057	4095	5105	7512	8609	263	2057	4095	5105	7512	8609
			Isolator Y-Dimension (mm)	34						2206					
			Point Load (kgs)	314	826	1148	1148	417	417	285	830	1189	1189	441	441
030	3	C	Isolator X-Dimension (mm)	263	2057	3638	4748	6232	8609	259	2055	3635	4745	6228	8606
			Isolator Y-Dimension (mm)	34						2206					
			Point Load (kgs)	323	818	939	939	491	491	323	757	1018	1018	495	495
030	5	C	Isolator X-Dimension (mm)	263	2057	3663	4755	7047	9726	263	2057	3663	4755	7047	9726
			Isolator Y-Dimension (mm)	34						2206					
			Point Load (kgs)	395	658	991	991	749	391	347	704	1016	1016	807	391
030	8	E	Isolator X-Dimension (mm)	260	2054	4081	5102	7579	9723	260	2054	4081	5102	7579	9723
			Isolator Y-Dimension (mm)	34						2206					
			Point Load (kgs)	363	908	970	970	842	391	358	893	1014	1014	879	391
031	8	E	Isolator X-Dimension (mm)	263	2057	4084	5105	7582	10843	263	2057	4084	5105	7582	10843
			Isolator Y-Dimension (mm)	34						2206					
			Point Load (kgs)	357	922	938	938	1003	459	353	907	982	982	1040	459
032	3	E	Isolator X-Dimension (mm)	263	2057	4084	5105	7582	8609	263	2057	4084	5105	7582	8609
			Isolator Y-Dimension (mm)	34						2206					
			Point Load (kgs)	318	803	1224	1224	416	416	288	814	1213	1213	437	437
033	3	C	Isolator X-Dimension (mm)	263	2057	3636	4781	6232	9726	263	2057	3636	4781	6232	9726
			Isolator Y-Dimension (mm)	34						2206					
			Point Load (kgs)	261	1329	404	404	1518	391	200	1441	321	321	1633	391
034	3	E	Isolator X-Dimension (mm)	260	2054	4081	5102	7579	9723	260	2054	4081	5102	7579	9723
			Isolator Y-Dimension (mm)	34						2206					
			Point Load (kgs)	363	905	1025	1025	866	391	358	892	1025	1025	885	391
034	5	E	Isolator X-Dimension (mm)	263	2057	4084	5105	7582	10843	263	2057	4084	5105	7582	10843
			Isolator Y-Dimension (mm)	34						2206					
			Point Load (kgs)	358	919	992	992	1026	459	353	906	992	992	1046	459

NOTE: Weights shown for base unit; selected options may add weight to unit. Contact your nearest Johnson Controls Sales Office for weight data.

Isolator Details

ELASTOMERIC ISOLATOR

RD-Style Isolators

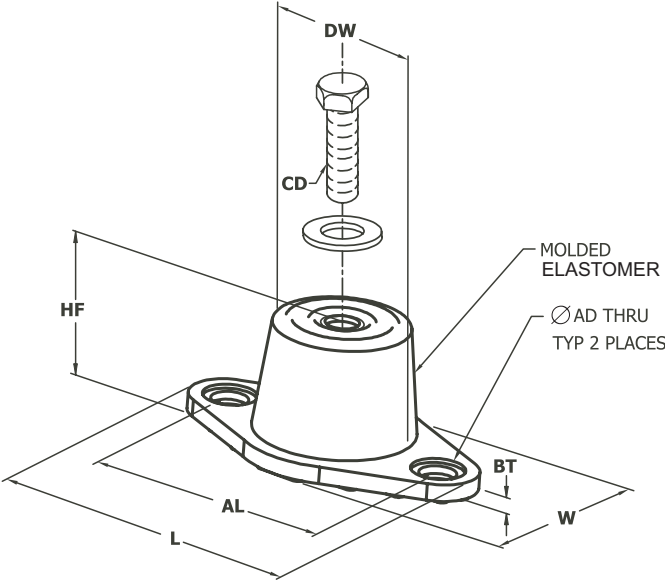

MOUNT TYPE	DIMENSION DATA (INCHES)							
	L	W	HF	AL	AD	BT	CD	DW
RD1-WR	3.13	1.75	1.25	2.38	0.34	0.19	5/16-18 UNC X 3/4	1.25
RD2-WR	3.88	2.38	1.75	3.00	0.34	0.22	3/8-16 UNC X 1	1.75
RD3-WR	5.50	3.38	2.88	4.13	0.56	0.25	1/2-13 UNC X 1	2.50
RD4-WR	6.25	4.63	2.75	5.00	0.56	0.38	1/2-13 UNC X 1	3.00

MODEL NUMBER	ISOLATOR COLOR	WEIGHT RANGE (LBS)	WEIGHT RANGE (KGS)
RD-3-CHARCOAL-WR	CHARCOAL	Thru 825	Thru 374
RD-4-BRICK RED-WR	BRICK RED	826 - 1688	375 - 766
RD-4-CHARCOAL-WR	CHARCOAL	1689 - 4000	767 - 1814

ONE INCH DEFLECTION SPRING ISOLATOR

CPX-X-

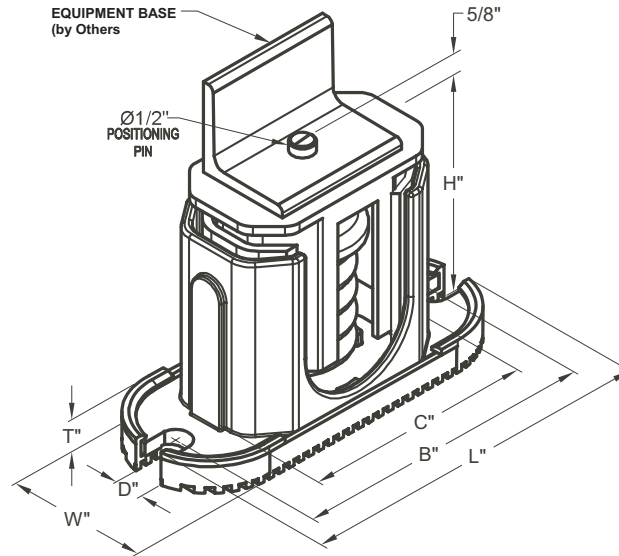

MOUNT TYPE	DIMENSION DATA (INCHES)						
	W	D	L	B	C	T	H
CP	3	5/8	7-3/4	6-1/2	4-3/4	1/2	5-5/8
C2P	3	5/8	10-1/2	9-1/4	7-3/4	9/16	6

MODEL NUMBER	COLOR CODE	RATED CAPACITY (FOR UNITS WITH ALL LOAD POINTS LESS THAN 1785 LBS (810 KG))	
		(LBS.)	(KG)
CP-1D-510	BLACK	Thru 434	Thru 197
CP-1D-900	DARK GREEN	435 - 765	198 - 347
CP-1D-1200	GRAY	766 - 1020	348 - 463
CP-1D-1360	WHITE	1021 - 1156	464 - 524
CP-1D-1785N	GRAY/RED	1157 - 1785	525 - 810

MODEL NUMBER	COLOR CODE	RATED CAPACITY (FOR UNITS WITH ANY LOAD POINT ABOVE 1518 LBS (689 KG))	
		(LBS.)	(KG)
C2P-1D-1350	DARK PURPLE	Thru 1148	Thru 521
C2P-1D-1800	DARK GREEN	1149 - 1530	522 - 694
C2P-1D-2400	GRAY	1531 - 2040	695 - 925
C2P-1D-2400	GRAY	1531 - 2040	695 - 925
C2P-1D-2720	WHITE	2041 - 2312	926 - 1049
C2P-1D-3570N	GRAY/RED	2313 - 3570	1050 - 1619

Isolator Details - continued

TWO INCH DEFLECTION, RESTRAINED SPRING ISOLATOR

Y2RS

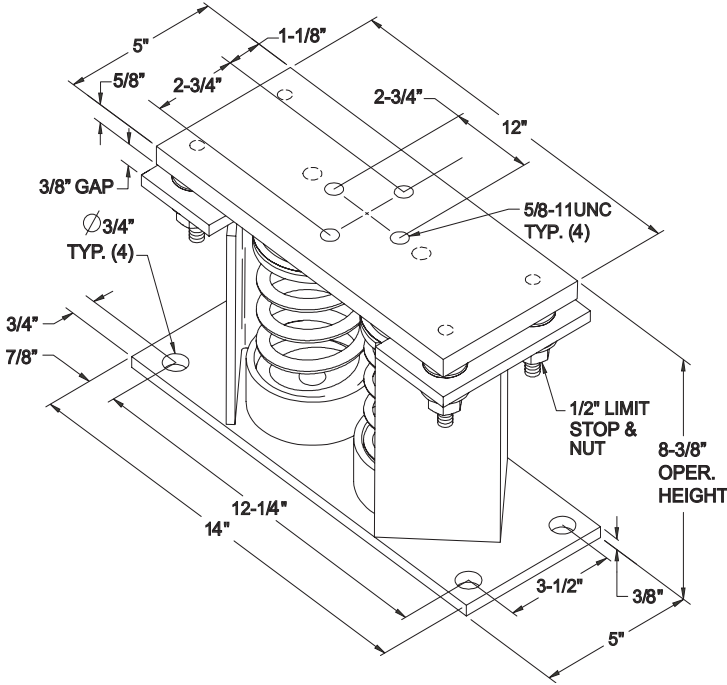

MODEL Y2RSI-2D RESTRAINED VIBRATION ISOLATOR FOR 2\"/>

MODEL NUMBER	ISOL. COLOR	WEIGHT RANGE (LBS)	WEIGHT RANGE (KGS)
Y2RSI-2D-460	GREEN	Thru 391	Thru 177
Y2RSI-2D-710	DARK BROWN	392 - 604	178 - 274
Y2RSI-2D-870	RED	605 - 740	275 - 336
Y2RSI-2D-1200N	RED/BLACK	741 - 1020	337 - 463
Y2RSI-2D-1690	PINK	1021 - 1437	464 - 652
Y2RSI-2D-2640N	PINK/GRAY	1438 - 2244	653 - 1018
Y2RSI-2D-2870N	PINK/GRAY/ORANGE	2245 - 2618	1019 - 1188
Y2RSI-2D-3280N	PINK/GRAY/DK.BROWN	2619 - 3740	1189 - 1696

INTENTIONALLY LEFT BLANK

Electrical Data

FIELD WIRING LUGS					STANDARD & ULTRA QUIET CONDENSER FANS					
					TERMINAL BLOCK		CIRCUIT BREAKER		NON-FUSED DISCONNECT SWITCH	
YVAA MODEL			INPUT VOLTS	INPUT FREQ	WIRES PER PHASE	LUG WIRE RANGE	WIRES PER PHASE	LUG WIRE RANGE	WIRES PER PHASE	LUG WIRE RANGE
FRAME	COND	EVAP								
015	3	B	200	60	4	#2 - 600 kcmil				
			230	60	4	#2 - 600 kcmil	4	4/0 ~ 500 kcmil		
			380	60	2	#2 - 600 kcmil		#2/0 ~ 500 kcmil	2	#2 - 600 kcmil
			400	50	2	#2 - 600 kcmil	2	#2/0 ~ 500 kcmil	2	#2 - 600 kcmil
			460	60	2	#2 - 600 kcmil	2	#1 ~ 500 kcmil	2	#2 - 600 kcmil
			575	60	2	#2 - 600 kcmil	2	#1 ~ 500 kcmil	2	#2 ~ 600 kcmil
016	5	B	200	60	4	#2 - 600 kcmil				
			230	60	4	#2 - 600 kcmil	4	4/0 ~ 500 kcmil		
			380	60	2	#2 - 600 kcmil	2	#2/0 ~ 500 kcmil	2	#2 - 600 kcmil
			400	50	2	#2 - 600 kcmil	2	#2/0 ~ 500 kcmil	2	#2 - 600 kcmil
			460	60	2	#2 - 600 kcmil	2	#1 ~ 500 kcmil	2	#2 - 600 kcmil
			575	60	2	#2 - 600 kcmil	2	#1 ~ 500 kcmil	2	#2 ~ 600 kcmil
017	8	C	200	60	4	#2 - 600 kcmil				
			230	60	4	#2 - 600 kcmil	4	4/0 ~ 500 kcmil		
			380	60	2	#2 - 600 kcmil	2	#2/0 ~ 500 kcmil	2	#2 - 600 kcmil
			400	50	2	#2 - 600 kcmil	2	#2/0 ~ 500 kcmil	2	#2 - 600 kcmil
			460	60	2	#2 - 600 kcmil	2	#1 ~ 500 kcmil	2	#2 - 600 kcmil
			575	60	2	#2 - 600 kcmil	2	#1 ~ 500 kcmil	2	#2 ~ 600 kcmil
018	3	A	200	60	4	#2 - 600 kcmil				
			230	60	4	#2 - 600 kcmil	4	4/0 ~ 500 kcmil		
			380	60	2	#2 - 600 kcmil	2	#1 ~ 500 kcmil	3	#2 ~ 600 kcmil
			400	50	2	#2 - 600 kcmil	2	#1 ~ 500 kcmil	3	#2 ~ 600 kcmil
			460	60	2	#2 - 600 kcmil	2	#1 ~ 500 kcmil	2	#2 - 600 kcmil
			575	60	2	#2 - 600 kcmil	2	#1 ~ 500 kcmil	2	#2 ~ 600 kcmil
019	5	A	200	60	4	#2 - 600 kcmil				
			230	60	4	#2 - 600 kcmil	4	4/0 ~ 500 kcmil		
			380	60	2	#2 - 600 kcmil	2	#1 ~ 500 kcmil	3	#2 ~ 600 kcmil
			400	50	2	#2 - 600 kcmil	2	#1 ~ 500 kcmil	3	#2 ~ 600 kcmil
			460	60	2	#2 - 600 kcmil	2	#1 ~ 500 kcmil	2	#2 - 600 kcmil
			575	60	2	#2 - 600 kcmil	2	#1 ~ 500 kcmil	2	#2 ~ 600 kcmil
019	8	B	200	60	4	#2 - 600 kcmil				
			230	60	4	#2 - 600 kcmil	4	4/0 ~ 500 kcmil		
			380	60	2	#2 - 600 kcmil	2	#1 ~ 500 kcmil	3	#2 ~ 600 kcmil
			400	50	2	#2 - 600 kcmil	2	#1 ~ 500 kcmil	3	#2 ~ 600 kcmil
			460	60	2	#2 - 600 kcmil	2	#1 ~ 500 kcmil	2	#2 - 600 kcmil
			575	60	2	#2 - 600 kcmil	2	#1 ~ 500 kcmil	2	#2 ~ 600 kcmil
020	0	C	200	60	4	#2 - 600 kcmil				
			230	60	4	#2 - 600 kcmil	4	4/0 ~ 500 kcmil		
			380	60	3	#2 - 600 kcmil	3	3/0 ~ 400 kcmil	3	#2 ~ 600 kcmil
			400	50	3	#2 - 600 kcmil	3	3/0 ~ 400 kcmil	3	#2 ~ 600 kcmil
			460	60	2	#2 - 600 kcmil	2	#1 ~ 500 kcmil	3	#2 - 600 kcmil
			575	60	2	#2 - 600 kcmil	2	#1 ~ 500 kcmil	2	#2 ~ 600 kcmil
021	3	A	200	60	4	#2 - 600 kcmil				
			230	60	4	#2 - 600 kcmil	4	4/0 ~ 500 kcmil		
			380	60	2	#2 - 600 kcmil	2	#1 ~ 500 kcmil	3	#2 ~ 600 kcmil
			400	50	2	#2 - 600 kcmil	2	#1 ~ 500 kcmil	3	#2 ~ 600 kcmil
			460	60	2	#2 - 600 kcmil	2	#1 ~ 500 kcmil	2	#2 - 600 kcmil
			575	60	2	#2 - 600 kcmil	2	#1 ~ 500 kcmil	2	#2 ~ 600 kcmil
021	5	C	200	60	4	#2 - 600 kcmil				
			230	60	4	#2 - 600 kcmil	4	4/0 ~ 500 kcmil		
			380	60	2	#2 - 600 kcmil	2	#1 ~ 500 kcmil	3	#2 ~ 600 kcmil
			400	50	2	#2 - 600 kcmil	2	#1 ~ 500 kcmil	3	#2 ~ 600 kcmil
			460	60	2	#2 - 600 kcmil	2	#1 ~ 500 kcmil	2	#2 - 600 kcmil
			575	60	2	#2 - 600 kcmil	2	#1 ~ 500 kcmil	2	#2 ~ 600 kcmil
021	8	C	200	60	4	#2 - 600 kcmil				
			230	60	4	#2 - 600 kcmil	4	4/0 ~ 500 kcmil		
			380	60	2	#2 - 600 kcmil	2	#1 ~ 500 kcmil	3	#2 ~ 600 kcmil
			400	50	2	#2 - 600 kcmil	2	#1 ~ 500 kcmil	3	#2 ~ 600 kcmil
			460	60	2	#2 - 600 kcmil	2	#1 ~ 500 kcmil	2	#2 - 600 kcmil
			575	60	2	#2 - 600 kcmil	2	#1 ~ 500 kcmil	2	#2 ~ 600 kcmil

FIELD WIRING LUGS					HIGH AIRFLOW/HIGH STATIC CONDENSER FANS					
					TERMINAL BLOCK		CIRCUIT BREAKER		NON-FUSED DISCONNECT SWITCH	
YVAA MODEL			INPUT VOLTS	INPUT FREQ	WIRE PER PHASE	LUG WIRE RANGE	WIRES PER PHASE	LUG WIRE RANGE	WIRES PER PHASE	LUG WIRE RANGE
FRAME	COND	EVAP								
015	3	B	200	60	4	#1/0 ~ 700 kcmil				
			230	60	4	#2 - 600 kcmil	4	4/0 ~ 500 kcmil		
			380	60	2	#2 - 600 kcmil	2	#1 ~ 500 kcmil	3	#2 ~ 600 kcmil
			400	50	2	#2 - 600 kcmil	2	#1 ~ 500 kcmil	3	#2 ~ 600 kcmil
			460	60	2	#2 - 600 kcmil	2	#1 ~ 500 kcmil	3	#2 ~ 600 kcmil
016	5	B	575	60	2	#2 - 600 kcmil	2	#1 ~ 500 kcmil	2	#2 ~ 600 kcmil
			200	60	4	#1/0 ~ 700 kcmil				
			230	60	4	#2 - 600 kcmil	4	4/0 ~ 500 kcmil		
			380	60	2	#2 - 600 kcmil	2	#1 ~ 500 kcmil	3	#2 ~ 600 kcmil
			400	50	2	#2 - 600 kcmil	2	#1 ~ 500 kcmil	3	#2 ~ 600 kcmil
017	8	C	460	60	2	#2 - 600 kcmil	2	#1 ~ 500 kcmil	3	#2 ~ 600 kcmil
			575	60	2	#2 - 600 kcmil	2	#1 ~ 500 kcmil	2	#2 ~ 600 kcmil
			200	60	4	#1/0 ~ 700 kcmil				
			230	60	4	#2 - 600 kcmil	4	4/0 ~ 500 kcmil		
			380	60	2	#2 - 600 kcmil	2	#1 ~ 500 kcmil	3	#2 ~ 600 kcmil
018	3	A	400	50	3	#2 - 600 kcmil	3	3/0 ~ 400 kcmil	3	#2 ~ 600 kcmil
			460	60	2	#2 - 600 kcmil	2	#1 ~ 500 kcmil	3	#2 ~ 600 kcmil
			575	60	2	#2 - 600 kcmil	2	#1 ~ 500 kcmil	2	#2 ~ 600 kcmil
			200	60	4	#1/0 ~ 700 kcmil				
			230	60	4	#2 - 600 kcmil	4	4/0 ~ 500 kcmil		
019	5	A	380	60	3	#2 - 600 kcmil	3	3/0 ~ 400 kcmil	3	#2 ~ 600 kcmil
			400	50	3	#2 - 600 kcmil	3	3/0 ~ 400 kcmil	3	#2 ~ 600 kcmil
			460	60	2	#2 - 600 kcmil	2	#1 ~ 500 kcmil	3	#2 ~ 600 kcmil
			575	60	2	#2 - 600 kcmil	2	#1 ~ 500 kcmil	2	#2 ~ 600 kcmil
			200	60	4	#1/0 ~ 700 kcmil				
019	8	B	230	60	4	#2 - 600 kcmil	4	4/0 ~ 500 kcmil		
			380	60	3	#2 - 600 kcmil	3	3/0 ~ 400 kcmil	3	#2 ~ 600 kcmil
			400	50	3	#2 - 600 kcmil	3	3/0 ~ 400 kcmil	3	#2 ~ 600 kcmil
			460	60	2	#2 - 600 kcmil	2	#1 ~ 500 kcmil	3	#2 ~ 600 kcmil
			575	60	2	#2 - 600 kcmil	2	#1 ~ 500 kcmil	2	#2 ~ 600 kcmil
020	0	C	200	60	4	#1/0 ~ 700 kcmil				
			230	60	4	#2 - 600 kcmil	4	4/0 ~ 500 kcmil		
			380	60	3	#2 - 600 kcmil	3	3/0 ~ 400 kcmil	3	#2 ~ 600 kcmil
			400	50	3	#2 - 600 kcmil	3	3/0 ~ 400 kcmil	3	#2 ~ 600 kcmil
			460	60	3	#2 - 600 kcmil	3	3/0 ~ 400 kcmil	3	#2 ~ 600 kcmil
021	3	A	575	60	2	#2 - 600 kcmil	2	#1 ~ 500 kcmil	2	#2 ~ 600 kcmil
			200	60	4	#1/0 ~ 700 kcmil				
			230	60	4	#2 - 600 kcmil	4	4/0 ~ 500 kcmil		
			380	60	3	#2 - 600 kcmil	3	3/0 ~ 400 kcmil	3	#2 ~ 600 kcmil
			400	50	3	#2 - 600 kcmil	3	3/0 ~ 400 kcmil	3	#2 ~ 600 kcmil
021	5	C	460	60	2	#2 - 600 kcmil	2	#1 ~ 500 kcmil	3	#2 ~ 600 kcmil
			575	60	2	#2 - 600 kcmil	2	#1 ~ 500 kcmil	2	#2 ~ 600 kcmil
			200	60	4	#1/0 ~ 700 kcmil				
			230	60	4	#2 - 600 kcmil	4	4/0 ~ 500 kcmil		
			380	60	3	#2 - 600 kcmil	3	3/0 ~ 400 kcmil	3	#2 ~ 600 kcmil
021	8	C	400	50	3	#2 - 600 kcmil	3	3/0 ~ 400 kcmil	3	#2 ~ 600 kcmil
			460	60	2	#2 - 600 kcmil	2	#1 ~ 500 kcmil	3	#2 ~ 600 kcmil
			575	60	2	#2 - 600 kcmil	2	#1 ~ 500 kcmil	2	#2 ~ 600 kcmil
			200	60	4	#1/0 ~ 700 kcmil				
			230	60	4	#2 - 600 kcmil	4	4/0 ~ 500 kcmil		

Electrical Data - continued

FIELD WIRING LUGS					STANDARD & ULTRA QUIET CONDENSER FANS					
					TERMINAL BLOCK		CIRCUIT BREAKER		NON-FUSED DISCONNECT SWITCH	
YVAA MODEL			INPUT VOLTS	INPUT FREQ	WIRES PER PHASE	LUG WIRE RANGE	WIRES PER PHASE	LUG WIRE RANGE	WIRES PER PHASE	LUG WIRE RANGE
FRAME	COND	EVAP								
023	3	B	200	60	4	#2 - 600 kcmil				
			230	60	4	#2 - 600 kcmil	4	4/0 ~ 500 kcmil		
			380	60	3	#2 - 600 kcmil	3	3/0 ~ 400 kcmil	3	#2 ~ 600 kcmil
			400	50	3	#2 - 600 kcmil	3	3/0 ~ 400 kcmil	3	#2 ~ 600 kcmil
			460	60	2	#2 - 600 kcmil	2	#1 ~ 500 kcmil	3	#2 ~ 600 kcmil
024	5	C	575	60	2	#2 - 600 kcmil	2	#1 ~ 500 kcmil	2	#2 ~ 600 kcmil
			200	60	4	#2 - 600 kcmil				
			230	60	4	#2 - 600 kcmil	4	4/0 ~ 500 kcmil		
			380	60	3	#2 - 600 kcmil	3	3/0 ~ 400 kcmil	3	#2 ~ 600 kcmil
			400	50	3	#2 - 600 kcmil	3	3/0 ~ 400 kcmil	3	#2 ~ 600 kcmil
024	8	C	460	60	2	#2 - 600 kcmil	2	#1 ~ 500 kcmil	3	#2 ~ 600 kcmil
			575	60	2	#2 - 600 kcmil	2	#1 ~ 500 kcmil	2	#2 ~ 600 kcmil
			200	60	4	#2 - 600 kcmil				
			230	60	4	#2 - 600 kcmil	4	4/0 ~ 500 kcmil		
			380	60	3	#2 - 600 kcmil	3	3/0 ~ 400 kcmil	3	#2 ~ 600 kcmil
026	3	B	400	50	3	#2 - 600 kcmil	3	3/0 ~ 400 kcmil	3	#2 ~ 600 kcmil
			460	60	2	#2 - 600 kcmil	2	#1 ~ 500 kcmil	3	#2 ~ 600 kcmil
			575	60	2	#2 - 600 kcmil	2	#1 ~ 500 kcmil	2	#2 ~ 600 kcmil
			200	60	4	#2 - 600 kcmil				
			230	60	4	#2 - 600 kcmil	4	4/0 ~ 500 kcmil		
027	3	D	380	60	3	#2 - 600 kcmil	3	3/0 ~ 400 kcmil	3	#2 ~ 600 kcmil
			400	50	3	#2 - 600 kcmil	3	3/0 ~ 400 kcmil	3	#2 ~ 600 kcmil
			460	60	2	#2 - 600 kcmil	2	#1 ~ 500 kcmil	3	#2 ~ 600 kcmil
			575	60	2	#2 - 600 kcmil	2	#1 ~ 500 kcmil	2	#2 ~ 600 kcmil
			200	60	4	#2 - 600 kcmil				
027	5	E	230	60	4	#2 - 600 kcmil	4	4/0 ~ 500 kcmil		
			380	60	3	#2 - 600 kcmil	3	3/0 ~ 400 kcmil	3	#2 ~ 600 kcmil
			400	50	3	#2 - 600 kcmil	3	3/0 ~ 400 kcmil	3	#2 ~ 600 kcmil
			460	60	2	#2 - 600 kcmil	2	#1 ~ 500 kcmil	3	#2 ~ 600 kcmil
			575	60	2	#2 - 600 kcmil	2	#1 ~ 500 kcmil	2	#2 ~ 600 kcmil
027	8	E	200	60	4	#2 - 600 kcmil				
			230	60	4	#2 - 600 kcmil	4	4/0 ~ 500 kcmil		
			380	60	3	#2 - 600 kcmil	3	3/0 ~ 400 kcmil	3	#2 ~ 600 kcmil
			400	50	3	#2 - 600 kcmil	3	3/0 ~ 400 kcmil	3	#2 ~ 600 kcmil
			460	60	2	#2 - 600 kcmil	2	#1 ~ 500 kcmil	3	#2 ~ 600 kcmil
029	5	E	575	60	3	#2 - 600 kcmil	3	#3/0 ~ 400 kcmil	3	#2 ~ 600 kcmil
			200	60						
			230	60						
			380	60	3	#2 - 600 kcmil	4	#4/0 ~ 500 kcmil	4*	#2 - 600 kcmil
			400	50	3	#2 - 600 kcmil	4	#4/0 ~ 500 kcmil	3	#2 ~ 600 kcmil
030	3	C	460	60	3	#2 - 600 kcmil	3	#3/0 ~ 400 kcmil	3	#2 ~ 600 kcmil
			575	60	3	#2 - 600 kcmil	3	#3/0 ~ 400 kcmil	3	#2 ~ 600 kcmil
			200	60						
			230	60						
			380	60	3	#2 - 600 kcmil	4	#4/0 ~ 500 kcmil	4*	#2 - 600 kcmil
030	5	C	400	50	3	#2 - 600 kcmil	4	#4/0 ~ 500 kcmil	3	#2 ~ 600 kcmil
			460	60	3	#2 - 600 kcmil	3	#3/0 ~ 400 kcmil	3	#2 ~ 600 kcmil
			575	60	3	#2 - 600 kcmil	3	#3/0 ~ 400 kcmil	3	#2 ~ 600 kcmil
			200	60						
			230	60						

* Up to 4 wires per phase, consisting of 2 lugs per phase where each lug can accommodate 2 wires.

FIELD WIRING LUGS					HIGH AIRFLOW/HIGH STATIC CONDENSER FANS					
					TERMINAL BLOCK		CIRCUIT BREAKER		NON-FUSED DISCONNECT SWITCH	
YVAA MODEL			INPUT VOLTS	INPUT FREQ	WIRE PER PHASE	LUG WIRE RANGE	WIRES PER PHASE	LUG WIRE RANGE	WIRES PER PHASE	LUG WIRE RANGE
FRAME	COND	EVAP								
023	3	B	200	60	4	#1/0 ~ 700 kcmil				
			230	60	4	#2 - 600 kcmil	4	4/0 ~ 500 kcmil		
			380	60	3	#2 - 600 kcmil	3	3/0 ~ 400 kcmil	3	#2 ~ 600 kcmil
			400	50	3	#2 - 600 kcmil	3	3/0 ~ 400 kcmil	3	#2 ~ 600 kcmil
			460	60	3	#2 - 600 kcmil	3	3/0 ~ 400 kcmil	3	#2 ~ 600 kcmil
024	5	C	575	60	2	#2 - 600 kcmil	2	#1 - 500 kcmil	2	#2 ~ 600 kcmil
			200	60	4	#1/0 ~ 700 kcmil				
			230	60	4	#2 - 600 kcmil	4	4/0 ~ 500 kcmil		
			380	60	3	#2 - 600 kcmil	3	3/0 ~ 400 kcmil	3	#2 ~ 600 kcmil
			400	50	3	#2 - 600 kcmil	3	3/0 ~ 400 kcmil	3	#2 ~ 600 kcmil
024	8	C	460	60	3	#2 - 600 kcmil	3	3/0 ~ 400 kcmil	3	#2 ~ 600 kcmil
			575	60	2	#2 - 600 kcmil	2	#1 - 500 kcmil	2	#2 ~ 600 kcmil
			200	60	4	#1/0 ~ 700 kcmil				
			230	60	4	#2 - 600 kcmil	4	4/0 ~ 500 kcmil		
			380	60	3	#2 - 600 kcmil	3	3/0 ~ 400 kcmil	3	#2 ~ 600 kcmil
026	3	B	400	50	3	#2 - 600 kcmil	3	3/0 ~ 400 kcmil	3	#2 ~ 600 kcmil
			460	60	3	#2 - 600 kcmil	3	3/0 ~ 400 kcmil	3	#2 ~ 600 kcmil
			575	60	2	#2 - 600 kcmil	2	#1 - 500 kcmil	2	#2 ~ 600 kcmil
			200	60	4	#1/0 ~ 700 kcmil				
			230	60	4	#2 - 600 kcmil	4	4/0 ~ 500 kcmil		
027	3	D	380	60	3	#2 - 600 kcmil	3	3/0 ~ 400 kcmil	3	#2 ~ 600 kcmil
			400	50	3	#2 - 600 kcmil	3	3/0 ~ 400 kcmil	3	#2 ~ 600 kcmil
			460	60	3	#2 - 600 kcmil	3	3/0 ~ 400 kcmil	3	#2 ~ 600 kcmil
			575	60	2	#2 - 600 kcmil	2	#1 - 500 kcmil	2	#2 ~ 600 kcmil
			200	60	4	#1/0 ~ 700 kcmil				
027	5	E	230	60	4	#2 - 600 kcmil	4	4/0 ~ 500 kcmil		
			380	60	3	#2 - 600 kcmil	3	3/0 ~ 400 kcmil	3	#2 ~ 600 kcmil
			400	50	3	#2 - 600 kcmil	3	3/0 ~ 400 kcmil	3	#2 ~ 600 kcmil
			460	60	3	#2 - 600 kcmil	3	3/0 ~ 400 kcmil	3	#2 ~ 600 kcmil
			575	60	2	#2 - 600 kcmil	2	#1 - 500 kcmil	2	#2 ~ 600 kcmil
027	8	E	200	60	4	#1/0 ~ 700 kcmil				
			230	60	4	#2 - 600 kcmil	4	4/0 ~ 500 kcmil		
			380	60	3	#2 - 600 kcmil	3	3/0 ~ 400 kcmil	3	#2 ~ 600 kcmil
			400	50	3	#2 - 600 kcmil	3	3/0 ~ 400 kcmil	3	#2 ~ 600 kcmil
			460	60	3	#2 - 600 kcmil	3	3/0 ~ 400 kcmil	3	#2 ~ 600 kcmil
029	5	E	575	60	3	#2 - 600 kcmil	3	#3/0 ~ 400 kcmil	3	#2 - 600 kcmil
			200	60						
			230	60						
			380	60	4	#2 - 600 kcmil	4	#4/0 ~ 500 kcmil	4*	#2 - 600 kcmil
			400	50	4	#2 - 600 kcmil	4	#4/0 ~ 500 kcmil	4*	#2 - 600 kcmil
030	3	C	460	60	3	#2 - 600 kcmil	4	#4/0 ~ 500 kcmil	3	#2 - 600 kcmil
			575	60	3	#2 - 600 kcmil	3	#3/0 ~ 400 kcmil	3	#2 - 600 kcmil
			200	60						
			230	60						
			380	60	4	#2 - 600 kcmil	4	#4/0 ~ 500 kcmil	4*	#2 - 600 kcmil
030	5	C	400	50	4	#2 - 600 kcmil	4	#4/0 ~ 500 kcmil	4*	#2 - 600 kcmil
			460	60	3	#2 - 600 kcmil	4	#4/0 ~ 500 kcmil	3	#2 - 600 kcmil
			575	60	3	#2 - 600 kcmil	3	#3/0 ~ 400 kcmil	3	#2 - 600 kcmil
			200	60						
			230	60						

* Up to 4 wires per phase, consisting of 2 lugs per phase where each lug can accommodate 2 wires.

Electrical Data - continued

FIELD WIRING LUGS					STANDARD & ULTRA QUIET CONDENSER FANS					
					TERMINAL BLOCK		CIRCUIT BREAKER		NON-FUSED DISCONNECT SWITCH	
YVAA MODEL			INPUT VOLTS	INPUT FREQ	WIRES PER PHASE	LUG WIRE RANGE	WIRES PER PHASE	LUG WIRE RANGE	WIRES PER PHASE	LUG WIRE RANGE
FRAME	COND	EVAP								
030	8	E	200	60						
			230	60						
			380	60	3	#2 - 600 kcmil	4	#4/0 ~ 500 kcmil	4*	#2 - 600 kcmil
			400	50	3	#2 - 600 kcmil	4	#4/0 ~ 500 kcmil	3	#2 ~ 600 kcmil
			460	60	3	#2 - 600 kcmil	3	#3/0 ~ 400 kcmil	3	#2 ~ 600 kcmil
031	8	E	575	60	3	#2 - 600 kcmil	3	#3/0 ~ 400 kcmil	3	#2 ~ 600 kcmil
			200	60						
			230	60						
			380	60	3	#2 - 600 kcmil	4	#4/0 ~ 500 kcmil	4*	#2 - 600 kcmil
			400	50	3	#2 - 600 kcmil	4	#4/0 ~ 500 kcmil	3	#2 ~ 600 kcmil
032	3	E	460	60	3	#2 - 600 kcmil	3	#3/0 ~ 400 kcmil	3	#2 ~ 600 kcmil
			575	60	3	#2 - 600 kcmil	3	#3/0 ~ 400 kcmil	3	#2 ~ 600 kcmil
			200	60						
			230	60						
			380	60	3	#2 - 600 kcmil	4	#4/0 ~ 500 kcmil	4*	#2 - 600 kcmil
033	3	C	400	50	3	#2 - 600 kcmil	4	#4/0 ~ 500 kcmil	3	#2 ~ 600 kcmil
			460	60	3	#2 - 600 kcmil	3	#3/0 ~ 400 kcmil	3	#2 ~ 600 kcmil
			575	60	3	#2 - 600 kcmil	3	#3/0 ~ 400 kcmil	3	#2 ~ 600 kcmil
			200	60						
			230	60						
034	3	E	380	60	3	#2 - 600 kcmil	4	#4/0 ~ 500 kcmil	4*	#2 - 600 kcmil
			400	50	3	#2 - 600 kcmil	4	#4/0 ~ 500 kcmil	3	#2 ~ 600 kcmil
			460	60	3	#2 - 600 kcmil	3	#3/0 ~ 400 kcmil	3	#2 ~ 600 kcmil
			575	60	3	#2 - 600 kcmil	3	#3/0 ~ 400 kcmil	3	#2 ~ 600 kcmil
			200	60						
034	5	E	230	60						
			380	60	3	#2 - 600 kcmil	4	#4/0 ~ 500 kcmil	4*	#2 - 600 kcmil
			400	50	3	#2 - 600 kcmil	4	#4/0 ~ 500 kcmil	3	#2 ~ 600 kcmil
			460	60	3	#2 - 600 kcmil	3	#3/0 ~ 400 kcmil	3	#2 ~ 600 kcmil
			575	60	3	#2 - 600 kcmil	3	#3/0 ~ 400 kcmil	3	#2 ~ 600 kcmil

* Up to 4 wires per phase, consisting of 2 lugs per phase where each lug can accommodate 2 wires.

FIELD WIRING LUGS					HIGH AIRFLOW/HIGH STATIC CONDENSER FANS					
					TERMINAL BLOCK		CIRCUIT BREAKER		NON-FUSED DISCONNECT SWITCH	
YVAA MODEL			INPUT VOLTS	INPUT FREQ	WIRE PER PHASE	LUG WIRE RANGE	WIRES PER PHASE	LUG WIRE RANGE	WIRES PER PHASE	LUG WIRE RANGE
FRAME	COND	EVAP								
030	8	E	200	60						
			230	60						
			380	60	4	#2 - 600 kcmil	4	#4/0 ~ 500 kcmil	4*	#2 - 600 kcmil
			400	50	4	#2 - 600 kcmil	4	#4/0 ~ 500 kcmil	4*	#2 - 600 kcmil
			460	60	3	#2 - 600 kcmil	4	#4/0 ~ 500 kcmil	3	#2 - 600 kcmil
			575	60	3	#2 - 600 kcmil	3	#3/0 ~ 400 kcmil	3	#2 - 600 kcmil
031	8	E	200	60						
			230	60						
			380	60	4	#2 - 600 kcmil	4	#4/0 ~ 500 kcmil	4*	#2 - 600 kcmil
			400	50	4	#2 - 600 kcmil	4	#4/0 ~ 500 kcmil	4*	#2 - 600 kcmil
			460	60	3	#2 - 600 kcmil	4	#4/0 ~ 500 kcmil	3	#2 - 600 kcmil
			575	60	3	#2 - 600 kcmil	3	#3/0 ~ 400 kcmil	3	#2 - 600 kcmil
032	3	E	200	60						
			230	60						
			380	60	4	#2 - 600 kcmil	4	#4/0 ~ 500 kcmil	4*	#2 - 600 kcmil
			400	50	4	#2 - 600 kcmil	4	#4/0 ~ 500 kcmil	4*	#2 - 600 kcmil
			460	60	3	#2 - 600 kcmil	4	#4/0 ~ 500 kcmil	3	#2 - 600 kcmil
			575	60	3	#2 - 600 kcmil	3	#3/0 ~ 400 kcmil	3	#2 - 600 kcmil
033	3	C	200	60						
			230	60						
			380	60	4	#2 - 600 kcmil	4	#4/0 ~ 500 kcmil	4*	#2 - 600 kcmil
			400	50	4	#2 - 600 kcmil	4	#4/0 ~ 500 kcmil	4*	#2 - 600 kcmil
			460	60	3	#2 - 600 kcmil	4	#4/0 ~ 500 kcmil	3	#2 - 600 kcmil
			575	60	3	#2 - 600 kcmil	3	#3/0 ~ 400 kcmil	3	#2 - 600 kcmil
034	3	E	200	60						
			230	60						
			380	60	4	#2 - 600 kcmil	4	#4/0 ~ 500 kcmil	4*	#2 - 600 kcmil
			400	50	4	#2 - 600 kcmil	4	#4/0 ~ 500 kcmil	4*	#2 - 600 kcmil
			460	60	3	#2 - 600 kcmil	4	#4/0 ~ 500 kcmil	3	#2 - 600 kcmil
			575	60	3	#2 - 600 kcmil	3	#3/0 ~ 400 kcmil	3	#2 - 600 kcmil
034	5	E	200	60						
			230	60						
			380	60	4	#2 - 600 kcmil	4	#4/0 ~ 500 kcmil	4*	#2 - 600 kcmil
			400	50	4	#2 - 600 kcmil	4	#4/0 ~ 500 kcmil	4*	#2 - 600 kcmil
			460	60	3	#2 - 600 kcmil	4	#4/0 ~ 500 kcmil	3	#2 - 600 kcmil
			575	60	3	#2 - 600 kcmil	3	#3/0 ~ 400 kcmil	3	#2 - 600 kcmil

* Up to 4 wires per phase, consisting of 2 lugs per phase where each lug can accommodate 2 wires.

Power Wiring

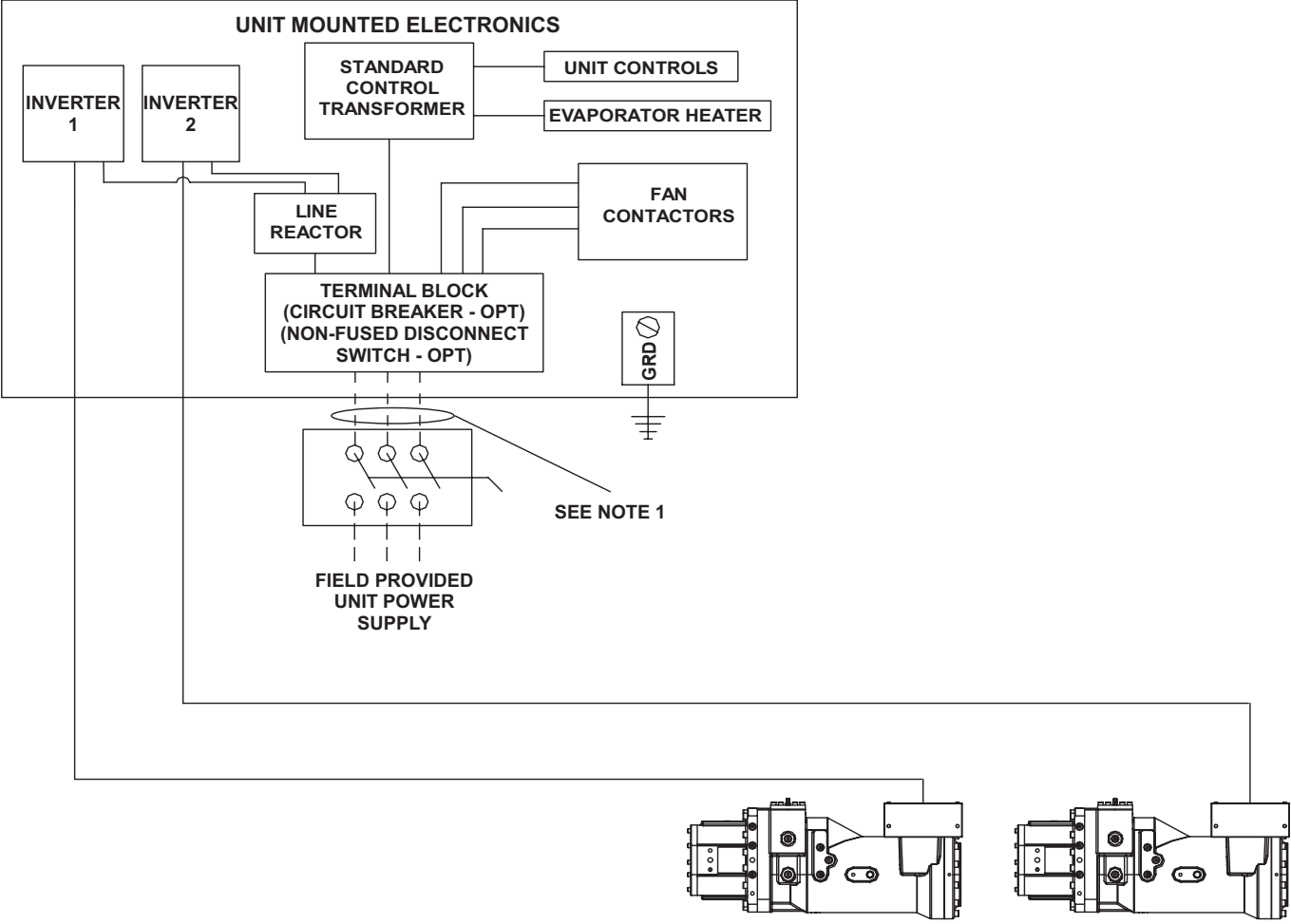

FIG. 12 – POWER WIRING DIAGRAM

NOTES:

- 1. ----- Dashed Line = Field Provided Wiring
- 2. The transformer is located in a separate box that is attached to the bottom of the control panel.

Customer Control Wiring

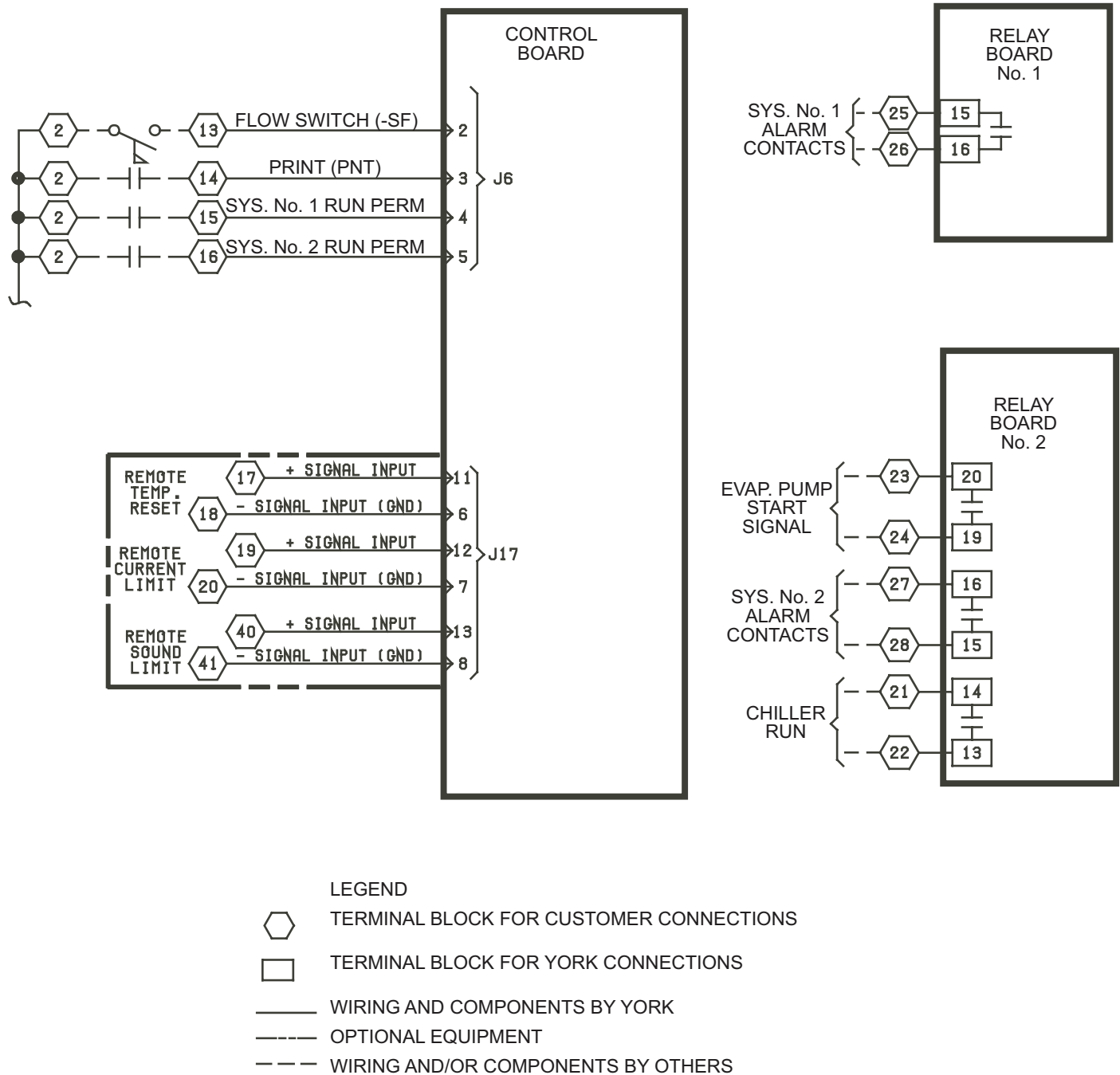
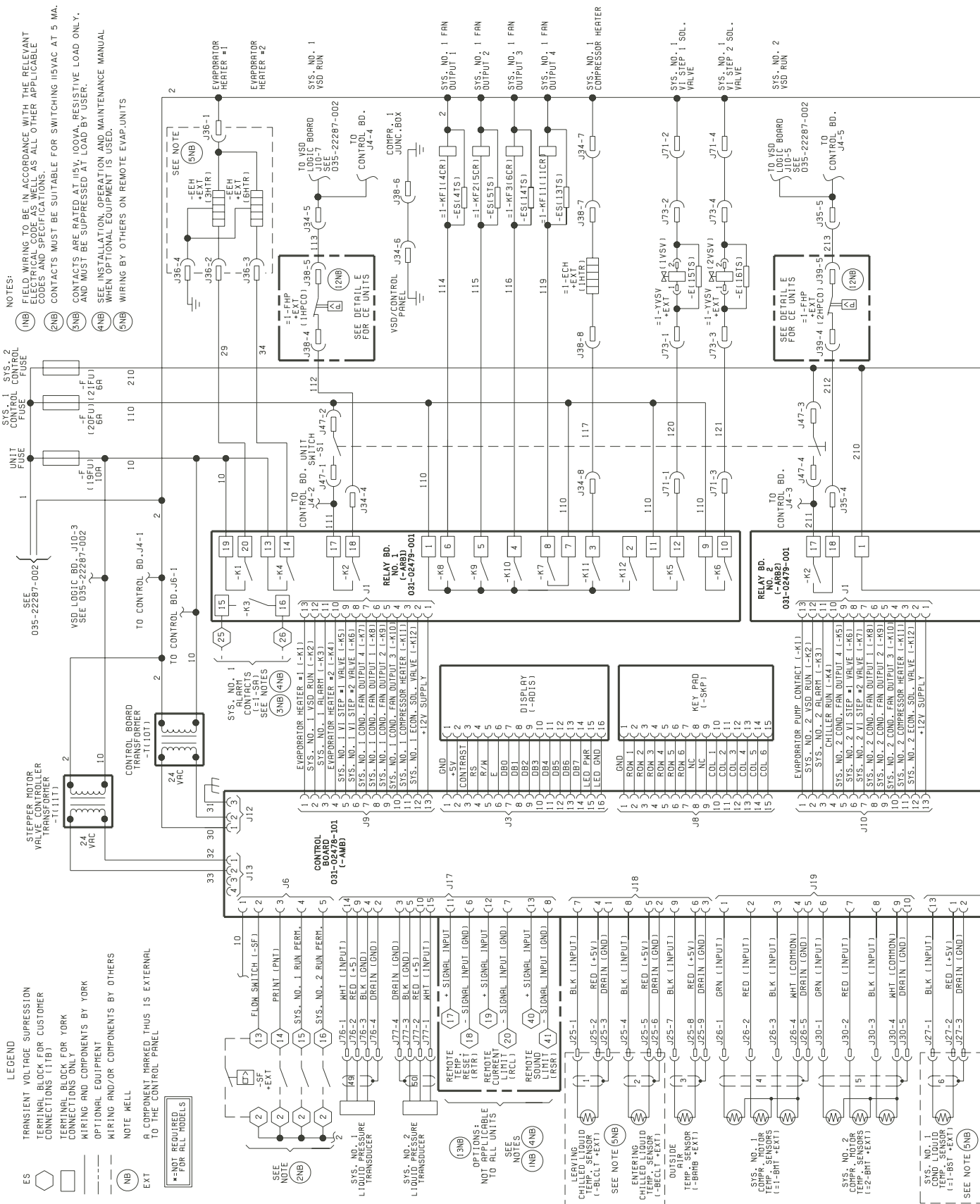
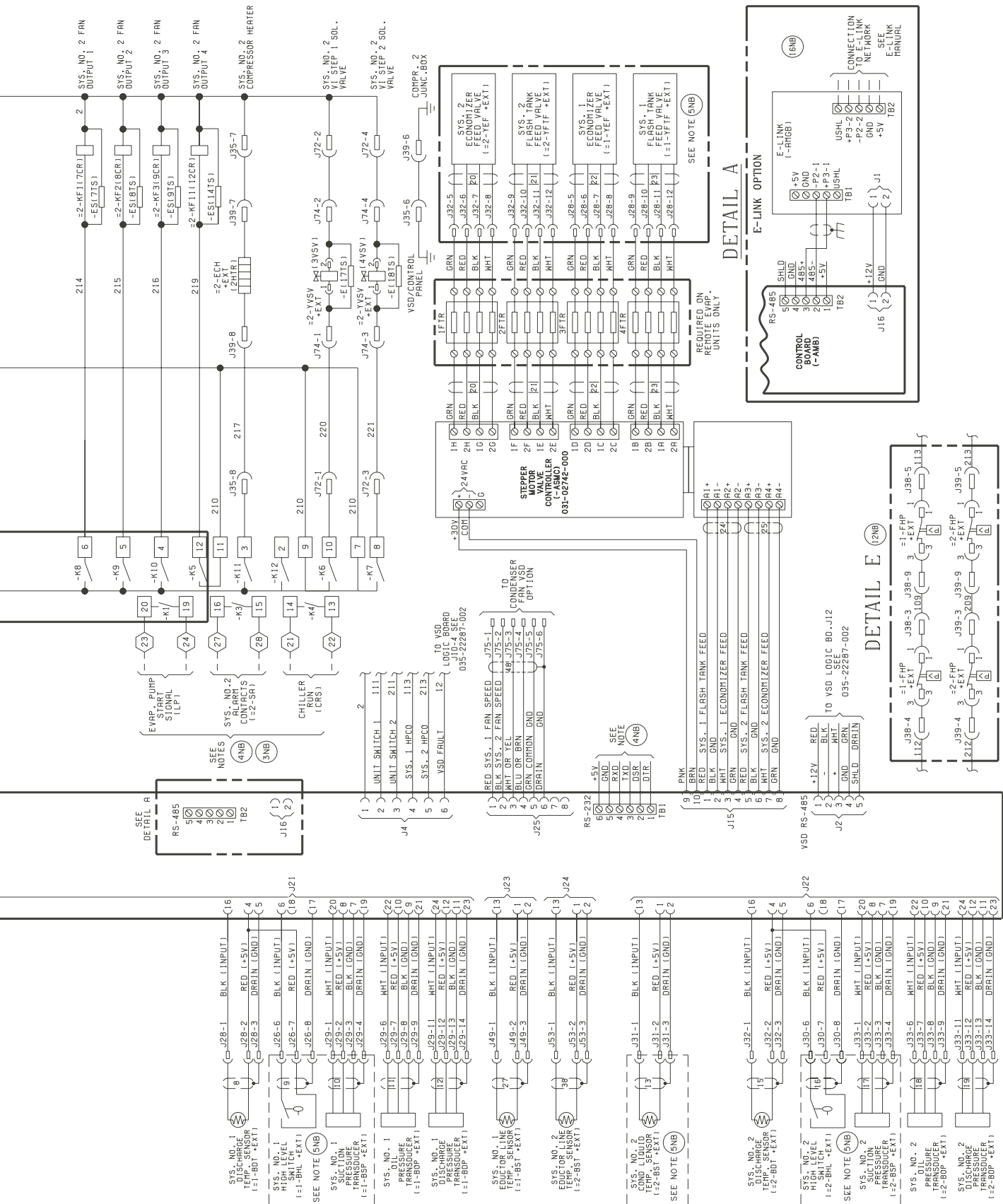

FIG. 13 – CUSTOMER CONTROL WIRING DIAGRAM

Control Wiring





SEE DETAIL A

DETAIL A

DETAIL E

Guide Specifications

PART 1 - GENERAL

1.01 GENERAL REQUIREMENTS

The requirements of this Section shall conform to the general provisions of the Contract, including General and Supplementary Conditions, Conditions of the Contract, and Contract Drawings.

1.02 SCOPE

Provide Microprocessor controlled, twin-screw compressor, air-cooled, liquid chillers of the scheduled capacities as shown and indicated on the Drawings, including but not limited to:

1. Chiller package
2. Charge of refrigerant and oil
3. Electrical power and control connections
4. Chilled liquid connections
5. Manufacturer start-up

1.03 QUALITY ASSURANCE

- A. Products shall be Designed, Tested, Rated and Certified in accordance with, and Installed in compliance with applicable sections of the following Standards and Codes:
1. AHRI 550/590 – Water Chilling Packages Using the Vapor Compression Cycle
 2. AHRI 370 – Sound Rating of Large Outdoor Refrigerating and Air-Conditioning Equipment
 3. ANSI/ASHRAE 15 – Safety Code for Mechanical Refrigeration
 4. ANSI/ASHRAE 34 – Number Designation and Safety Classification of Refrigerants
 5. ASHRAE 90.1 – Energy Standard for Buildings Except Low-Rise Residential Buildings
 6. ANSI/NFPA 70 – National Electrical Code (N.E.C.)
 7. ASME Boiler and Pressure Vessel Code, Section VIII, Division 1
 8. OSHA – Occupational Safety and Health Act
 9. Manufactured in facility registered to ISO 9001
 10. Conform to Intertek Testing Services for construction of chillers and provide ETL/cETL Listed Mark
- B. Factory Run Test: Chiller shall be pressure-tested, evacuated and fully charged with refrigerant and oil, and shall be factory operational run tested with water flowing through the vessel.

- C. Chiller manufacturer shall have a factory trained and supported service organization.
- D. Warranty: Manufacturer shall Warrant all equipment and material of its manufacture against defects in workmanship and/or material for a period of eighteen (18) months from date of shipment or twelve (12) months from date of start-up, whichever occurs first.

1.04 DELIVERY AND HANDLING

- A. Unit shall be delivered to job site fully assembled with all interconnecting refrigerant piping and internal wiring ready for field installation and charged with refrigerant and oil by the Manufacturer.
- B. Provide protective covering over vulnerable components for unit protection during shipment. Fit nozzles and open ends with plastic enclosures.
- C. Unit shall be stored and handled per Manufacturer's instructions.

PART 2 - PRODUCTS

2.01 MANUFACTURERS

- A. The design shown on the Drawings is based on YORK model YVAA chiller manufactured by Johnson Controls / YORK. Alternate equipment will be acceptable if the manufacturer's equipment meets the scheduled performance and complies with these specifications. If equipment manufactured by a manufacturer other than that scheduled is utilized, then the Mechanical Contractor shall be responsible for coordinating with the General Contractor and all affected Subcontractors to insure proper provisions for installation of the furnished unit. This coordination shall include, but not be limited to, the following:
1. Structural supports for units.
 2. Piping size and connection/header locations.
 3. Electrical power requirements and wire/conduit and overcurrent protection sizes.
 4. Chiller physical size on plant layout.
 5. Site noise considerations.
- B. The Mechanical Contractor shall be responsible for all costs incurred by the General Contractor, Subcontractors, and Consultants to modify the building provisions to accept the furnished alternate equipment.

2.02 GENERAL

- A. Description: Furnish, Install, and Commission factory assembled, charged, and operational run tested air-cooled screw compressor chiller as specified herein and shown on the Drawings. Chiller shall include, but is not limited to: a complete system with multiple independent refrigerant circuits, semi hermetic twin screw compressors, shell and tube hybrid falling film type evaporator, air-cooled condenser, R134a refrigerant, lubrication system, interconnecting wiring, safety and operating controls including capacity controller, control center, motor starting components, and special features as specified herein or required for safe, automatic operation.
- B. Operating Characteristics:
1. Provide low and high ambient temperature control options as required to ensure unit is capable of operation from 0°F to 125°F (-18°C to 52°C) ambient temperature.
 2. Provide capacity control system capable of reducing unit capacity to 10% of full load for 2 compressor units. Compressor shall start in unloaded condition. Application of factory installed hot gas bypass shall be acceptable as required to meet specified minimum load.
- C. Cabinet: Unit panels, structural elements, control boxes and heavy gauge structural base shall be constructed of painted galvanized steel. All exposed sheet steel shall be coated with baked on powder paint to meet 500-hour salt spray test in accordance with the ASTM B117 standard.
- D. Shipping: Unit shall ship in one piece and shall require installer to provide only a single evaporator inlet and outlet pipe connection. If providing chiller model that ships in multiple pieces, bid shall include all the material and field labor costs for factory authorized personnel to install a trim kit to connect the pieces as well as all interconnecting piping and wiring.

2.03 COMPRESSORS

- A. Compressors: Shall be direct drive, semi hermetic, rotary twin-screw type, including: muffler, temperature actuated 'off-cycle' heater, rain-tight terminal box, discharge shut-off service valve, and precision machined cast iron housing. Design working pressure of entire compressor, suction to discharge, shall be 350 psig (24 barg) or higher. Compressor shall be U.L. Recognized.

[OPTIONAL]: Suction shut-off service valve for each compressor

- B. Compressor Motors: Refrigerant suction-gas cooled accessible hermetic compressor motor, full suction gas flow through 0.006" (0.1524 mm) maximum mesh screen, with inherent internal thermal overload protection and external current overload on all three phases.
- C. Balancing Requirements: All rotating parts shall be statically and dynamically balanced.
- D. Lubrication System: External oil separators with no moving parts, 450 psig (31 barg) design working pressure, and ETL listing shall be provided on the chiller. Refrigerant system differential pressure shall provide oil flow through service replaceable, 0.5 micron, full flow, cartridge type oil filter internal to compressor. Filter bypass, less restrictive media, or oil pump not acceptable.
- E. Capacity Control: Compressors shall start at minimum load. Provide Microprocessor control to command compressor capacity to balance compressor capacity with cooling load.

2.04 REFRIGERANT CIRCUIT COMPONENTS

- A. Refrigerant: R-134a. Classified as Safety Group A1 according to ASHRAE 34
- B. Equipment supplied shall comply with LEED Energy & Atmosphere Credit 4, Enhanced Refrigerant Management.
- C. Each independent refrigerant circuit shall incorporate all components necessary for the designed operation including: liquid line shut-off valve with charging port, low side pressure relief device, removable core filter-drier and sight glass with moisture indicator.
- D. Chiller manufacturer shall provide an independent circuit for each compressor to provide maximum redundancy during chiller operation. If equipment does not have independent circuits per compressor, manufacturer shall provide owner one spare compressor of each unique size.
- E. Discharge lines shall be provided with manual compressor shut-off service valves.

Guide Specifications - continued

2.05 HEAT EXCHANGERS

A. Evaporator:

1. Evaporator shall be shell and tube, hybrid falling film type to optimize efficiency and refrigerant charge. Tubes shall be high-efficiency, internally and externally enhanced type copper tubes with 0.035" (0.89 mm) minimum wall thickness at all intermediate tube supports to provide maximum tube wall thickness at the support area. Each tube shall be roller expanded into the tube sheets providing a leak proof seal, and be individually replaceable. Independent refrigerant circuits shall be provided per compressor.

[OPTIONAL]: 3 pass arrangement.

2. Constructed, tested, and stamped in accordance with applicable sections of ASME pressure vessel code for minimum 235 psig (16 barg) refrigerant side design working pressure and 150 psig (10 barg) liquid side design working pressure.
3. Water boxes shall be removable to permit tube cleaning and replacement. Water boxes shall include liquid nozzle connections suitable for ANSI/AWWA C-606 couplings, welding, or flanges.

[OPTIONAL]: 150 psig (10.3 barg) ANSI raised-face weldable flanges. Flanges are field-welded by Contractor. Companion flanges, bolts, nuts, and gaskets are not included.

[OPTIONAL]: 150 psig (10.3 barg) ANSI raised-face flanges with ANSI/AWWA C-606 couplings. Flanges are field-mounted by Contractor. Companion flanges, bolts, nuts, and gaskets are not included.

[OPTIONAL]: 150 psig (10.3 barg) ANSI raised-face weldable flanges with companion flanges. Flanges are field-welded by Contractor. Bolts, nuts, and gaskets are not included.

[OPTIONAL]: 150 psig (10.3 barg) ANSI raised-face flanges with ANSI/AWWA C-606 couplings with companion flanges. Flanges are field-mounted by Contractor. Bolts, nuts, and gaskets are not included.

4. Provide vent and drain fittings, and thermostatically controlled heaters to protect to 0°F (-17.8°C) ambient temperature in off-cycle.

[OPTIONAL]: Provide freeze protection down to -20°F (-28°C) ambient temperature. A separate power connection for evaporator heaters is required and shall be provided by the Contractor.

5. Connection location: Chilled liquid inlet and outlet nozzle connections are located at rear (opposite control panel) end of unit.

[OPTIONAL]: Inlet and outlet nozzle connections

located at front end of unit. Available for select configurations.

B. Air-cooled Condenser:

1. Condenser coils shall be microchannel type, parallel flow aluminum alloy tubes metallurgically brazed as one piece to enhanced aluminum alloy fins. Condenser coils shall be made of a single material to avoid galvanic corrosion due to dissimilar metals. Tube and fin type condenser coils are an acceptable alternate when tubes and fins are fabricated of the same metal material to avoid galvanic corrosion due to dissimilar metals. Coils shall be designed for 350 psig (24 barg) or higher working pressure.

[OPTIONAL]: Post-coated epoxy dipped condenser microchannel: The unit shall be built with microchannel sections that have been applied with an electro-deposited and baked flexible epoxy coating that is finished with a polyurethane UV resistant top-coat suitable for highly corrosive applications.

[OPTIONAL]: Wire Panels: Heavy gauge, welded wire mesh coated to resist corrosion, to protect condenser coils from incidental damage and also restrict unauthorized access to internal components.

[OPTIONAL]: Louvered Panels (Condenser Coils): Painted steel to match unit panels, over external condenser coil faces.

[OPTIONAL]: Louvered Panels (Full Unit): Painted steel to match unit panels, over internal components.

[OPTIONAL]: Louvered/Wire Panels: Louvered steel panels on external condenser coil faces, painted to match unit panels. Heavy gauge, welded wire mesh, coated to resist corrosion, around base of machine to restrict unauthorized access.

[OPTIONAL]: End Hail Guard: Louvered steel panels on rear of unit (opposite end of control panel), painted to match unit panels.

[OPTIONAL]: V-Guard Panels: Steel panels installed over exposed condenser piping to protect from damage.

2. Low Sound Fans: Shall provide vertical air discharge from extended orifices. Fans shall be composed of corrosion resistant aluminum hub and glass-fiber-reinforced polypropylene composite blades molded into a low-noise airfoil section. Fan impeller shall be dynamically balanced for vibration-free operation. Fan guards of heavy gauge, PVC (polyvinyl chloride) coated or galvanized steel.

[**OPTIONAL**]: Ultra-Quiet Fans

[**OPTIONAL**]: High Airflow Fans

[**OPTIONAL**]: High Static Fans

3. Fan Motors: High efficiency, direct drive, 3-phase, insulation class "F", current protected, Totally Enclosed Air-Over (TEAO), with double sealed, permanently-lubricated ball bearings. Open Drip Proof (ODP) fan motors will not be acceptable.

2.06 INSULATION

- A. Material: Closed-cell, flexible, UV protected, thermal insulation complying with ASTM C 534 Type 2 (Sheet) for preformed flexible elastomeric cellular thermal insulation in sheet and tubular form.
- B. Thickness: 3/4" (19mm.)
[**OPTIONAL**]: 1-1/2" (38mm.)
- C. Thermal conductivity: 0.26 (BTU/HR-Ft²-°F/in) maximum at 75°F mean temperature.
- D. Factory-applied insulation over cold surfaces of liquid chiller components including evaporator shell, water boxes, and suction line. Liquid nozzles shall be insulated by Contractor after pipe installation.
- E. Adhesive: As recommended by insulation manufacturer and applied to 100 percent of insulation contact surface including all seams and joints.

2.07 ACOUSTICAL DATA

- A. Provide acoustical sound power or sound pressure level data in decibels (dB) at the scheduled eight (8) octave band center frequencies. A-weighted sound data alone is not acceptable.
- B. Provide all sound power or sound pressure level data at 100%, 75%, 50%, and 25% load.
- C. Supplied equipment shall not exceed scheduled sound power or sound pressure level data at any load point. The mechanical Contractor shall be responsible for any additional costs associated with equipment deviation.
- D. Acoustical performance ratings shall be in accordance with AHRI Standard 370
[**OPTIONAL**]: Provide factory-installed sound reduction enclosures and ultra-quiet fans to meet chiller sound levels scheduled at all load points.
[**OPTIONAL**]: Provide optional control input to limit sound output of the chiller based on time of day. Shall be programmable at the chiller panel or controlled

remotely via signal (4-20 mA or 0-10VDC) from BAS system. Chillers without this feature shall be provided with the necessary sound attenuation to meet the scheduled sound performance data at all load points.

2.08 POWER AND ELECTRICAL REQUIREMENTS

- A. Power/Control Panel:
 1. Factory installed and wired NEMA 3R, powder painted steel cabinets with tool lockable, hinged, latched, and gasket sealed outer doors equipped with wind struts for safer servicing. Provide main power connection(s), compressor starters and fan motor contactors, current overloads, and factory wiring.
 2. Panel shall include control display access door.
- B. Single Point Power:
 1. Provide single point power connection to chiller, shall be 3 phase of scheduled voltage.
 2. Terminal Block connections shall be provided at the point of incoming single point connection for field connection and interconnecting wiring to the compressors. Separate external protection must be supplied, by others, in the incoming power wiring, which must comply with local codes.
[**OPTIONAL**]: Single Point Disconnect: A non-fused disconnect and lockable external handle shall be supplied to isolate the unit power voltage for servicing. Separate external fusing must be supplied, by others, in the incoming power wiring which must comply with local codes.
[**OPTIONAL**]: Single Point Circuit Breaker: A unit-mounted Circuit Breaker with external lockable handle shall be supplied to isolate power voltage for servicing. Incoming power wiring must comply with local codes. Circuit breaker shall be sized to provide the motor branch circuit protection, short circuit protection and ground fault protection for the motor branch-circuit conductors, the motor control apparatus and the motors.
- C. Control Transformer: Power panel shall be supplied with a factory mounted and wired control transformer that will supply all unit control voltage from the main unit power supply. Transformer shall utilize scheduled line voltage on the primary side and provide 115V/1Ø on secondary.
- D. Short Circuit Withstand Rating of the chiller electrical enclosure shall be (380, 400, & 460V: minimum of 30,000 Amps [OR 65,000 Amps for Single Point Circuit

Guide Specifications - continued

Breaker].) Rating shall be published in accordance with UL508.

- E. Motor Starters: Motor starters shall be zero electrical inrush current (Variable Frequency Drives) or reduced inrush type (Closed transition Wye-Delta or Solid State) for minimum electrical inrush. Open transition Wye-Delta and Across the Line type starters will not be acceptable.
- F. Power Factor:
 1. Provide equipment with power factor correction capacitors as required to maintain a displacement power factor of 95% at all load conditions.
 2. The installing contractor is responsible for additional cost to furnish and install power factor correction capacitors if they are not factory mounted and wired.
- G. All exposed power wiring shall be routed through liquid-tight, UV-stabilized, non-metallic conduit.
- H. Supplied equipment shall not exceed scheduled Minimum Circuit Ampacity (MCA.) The mechanical Contractor shall be responsible for any additional costs associated with equipment deviation.

2.09 CONTROLS

- A. General:
 1. Provide automatic control of chiller operation including compressor start/stop and load/unload, anti-recycle timers, condenser fans, evaporator pump, evaporator heater, unit alarm contacts and run signal contacts.
 2. Chiller shall automatically reset to normal chiller operation after power failure.
 3. Unit operating software shall be stored in non-volatile memory. Field programmed set points shall be retained in lithium battery backed regulated time clock (RTC) memory for minimum 5 years.
 4. Alarm contacts shall be provided to remote alert for any unit or system safety fault.
- B. Display and Keypad:
 1. Provide minimum 80 character liquid crystal display that is both viewable in direct sunlight and has LED backlighting for nighttime viewing. Provide one keypad and display panel per chiller.
 2. Display and keypad shall be accessible through display access door without opening main control/electrical cabinet doors.
- C. Programmable Setpoints (within Manufacturer limits): Display language, chilled liquid cooling mode, local/remote control mode, display units mode, system lead/lag control mode, remote temperature reset, remote current limit, remote sound limit, low ambient temperature cutout enable/disable, leaving chilled liquid setpoint and range, maximum remote temperature reset.
- D. Display Data: Chilled liquid leaving and entering temperatures; outside ambient air temperature; lead system; evaporator pump status; active remote control; compressor suction, discharge, and oil pressures per refrigerant circuit; compressor discharge, motor, and oil temperatures per refrigerant circuit; saturation temperatures per refrigerant circuit; compressor speed; condenser fan status; condenser subcooling temperature; condenser drain valve percentage open; compressor capacity in percentage of Full Load Amps; compressor number of starts; run time; operating hours; evaporator heater status; history data for last ten shutdown faults; history data for last 20 normal (non-fault) shutdowns.
- E. Predictive Control Points: Unit controls shall avoid safety shutdown when operating outside design conditions by optimizing the chiller controls and cooling load output to stay online and avoid safety limits being reached. The system shall monitor the following parameters and maintain the maximum cooling output possible without shutdown of the equipment: motor current, suction pressure, discharge pressure, starter internal ambient temperature, and starter baseplate temperature.
- F. System Safeties: Shall cause individual compressor systems to perform auto-reset shut down if: high discharge pressure or temperature, low suction pressure, low motor current, high/low differential oil pressure, low discharge superheat, high motor temperature, system control voltage.
- G. Unit Safeties: Shall be automatic reset and cause compressors to shut down if: high or low ambient temperature, low leaving chilled liquid temperature,
 3. Display shall provide a minimum of unit setpoints, status, electrical data, temperature data, pressures, safety lockouts and diagnostics without the use of a coded display.
 4. Descriptions in English (or available language options), numeric data in English (or Metric) units.
 5. Sealed keypad shall include unit On/Off switch.

under voltage, flow switch operation. Contractor shall provide flow switch and wiring per chiller manufacturer requirements.

- H. Manufacturer shall provide any controls not listed above, necessary for automatic chiller operation. Mechanical Contractor shall provide field control wiring necessary to interface sensors to the chiller control system.

2.10 ACCESSORIES AND OPTIONS

Some accessories and options supersede standard product features. All options are factory-mounted unless otherwise noted.

A. CONTROLS OPTIONS:

1. Building Automation System Interface: Chiller to accept 4 to 20mA or 0 to 10 VDC input from BAS (by others) to reset the leaving chilled liquid temperature or load limit setpoint or both.
2. Gateway: Provides communication for Building Automation Systems, including BACnet (MS/TP), Modbus, N2, and LON. (Field Commissioned by BAS Manufacturer)
3. Thermal Storage: Provide special control logic and modifications to produce leaving chilled brine temperatures below 40°F (4.4°C.)

B. GENERAL OPTIONS:

1. Flow Switch: Vapor proof SPDT, NEMA 3R switch, 150 psig (10.3 barg), -20°F to 250°F (-28.9°C to 121.1°C.) (**Field Mounted by Contractor**)
2. Differential Pressure Switch: 3-45 psig (0.2-3 barg) range with 1/4" NPTE pressure connections. (**Field Mounted by Contractor**)
3. Chicago Code Relief Valve – Special relief valves per Chicago Code
4. Special Requirement Documents:
 - a. Special Requirement Document Package (SRDP) includes Pressure Vessel Report, Unit Run Test Report, Production System Check Sheet and Final Unit Inspection Check Sheet.

b. Materials Package includes steel mill material reports for vessels in addition to Pressure Vessel Report, Unit Run Test Report, Production System Check Sheet and Final Unit Inspection Check Sheet.

5. Vibration Isolation (All Options Field Mounted by Contractor):

- a. Elastomeric Isolators.
- b. 1" Deflection Spring Isolators: Level adjustable, spring and cage type isolators for mounting under the unit base rails.
- c. 2" Deflection Restrained Spring Isolators: Level adjustable, restrained mounts in rugged welded steel housing with vertical and horizontal limit stops. Housings shall be designed to withstand a minimum 1.0g accelerated force in all directions to 2" (50.8 mm.)

PART 3 - EXECUTION

3.01 INSTALLATION

- A. General: Rig and Install in full accordance with Manufacturer's requirements, Project drawings, and Contract documents.
- B. Location: Locate chiller as indicated on drawings, including cleaning and service maintenance clearance per Manufacturer instructions. Adjust and level chiller on support structure.
- C. Components: Installing Contractor shall provide and install all auxiliary devices and accessories for fully operational chiller.
- D. Electrical: Coordinate electrical requirements and connections for all power feeds with Electrical Contractor.
- E. Controls: Coordinate all control requirements and connections with Controls Contractor.
- F. Finish: Installing Contractor shall paint damaged and abraded factory finish with touch-up paint matching factory finish.

Unit Conversion

Values provided in this manual are in the English inch-pound (I-P) system.
The following factors can be used to convert from English to the most common SI Metric values.

MEASUREMENT	MULTIPLY THIS ENGLISH VALUE	BY	TO OBTAIN THIS METRIC VALUE
CAPACITY	TONS REFRIGERANT EFFECT (TON)	3.516	KILOWATTS (KW)
POWER	KILOWATTS (KW)	NO CHANGE	KILOWATTS (KW)
	HORSEPOWER (HP)	0.7457	KILOWATTS (KW)
FLOW RATE	GALLONS / MINUTE (GPM)	0.0631	LITERS / SECOND (L/S)
LENGTH	FEET (FT)	304.8	MILLIMETERS (MM)
	INCHES (IN)	25.4	MILLIMETERS (MM)
WEIGHT	POUNDS (LB)	0.4536	KILOGRAMS (KG)
VELOCITY	FEET / SECOND (FPS)	0.3048	METERS / SECOND (M/S)
PRESSURE DROP	FEET OF WATER (FT)	2.989	KILOPASCALS (KPA)
	POUNDS / SQ. INCH (PSI)	6.895	KILOPASCALS (K PA)

TEMPERATURE

To convert degrees Fahrenheit (°F) to degrees Celsius (°C), subtract 32° and multiply by 5/9 or 0.5556.

To convert a temperature range (i.e., 10°F or 12°F chilled water range) from Fahrenheit to Celsius, multiply by 5/9 or 0.5556.

FOULING FACTOR

ENGLISH I-P (ft ² °F hr/Btu)	EQUIVALENT SI METRIC (m ² k/kW)
0.0001	.018
0.00025	.044
0.0005	.088
0.00075	.132

EFFICIENCY

In the English I-P system, chiller efficiency is measured in kW / ton:

$$\text{kW / ton} = \frac{\text{kW input}}{\text{tons refrigerant effect}}$$

In the SI Metric system, chiller efficiency is measured in Coefficient of Performance (COP).

$$\text{COP} = \frac{\text{kW refrigeration effect}}{\text{kW input}}$$

kW / ton and COP are related as follows:

$$\text{kW/ton} = \frac{3.516}{\text{COP}}$$

$$\text{COP} = \frac{3.516}{\text{kW/ton}}$$